



South Sudan



# Secondary Physics

Student's Book

1

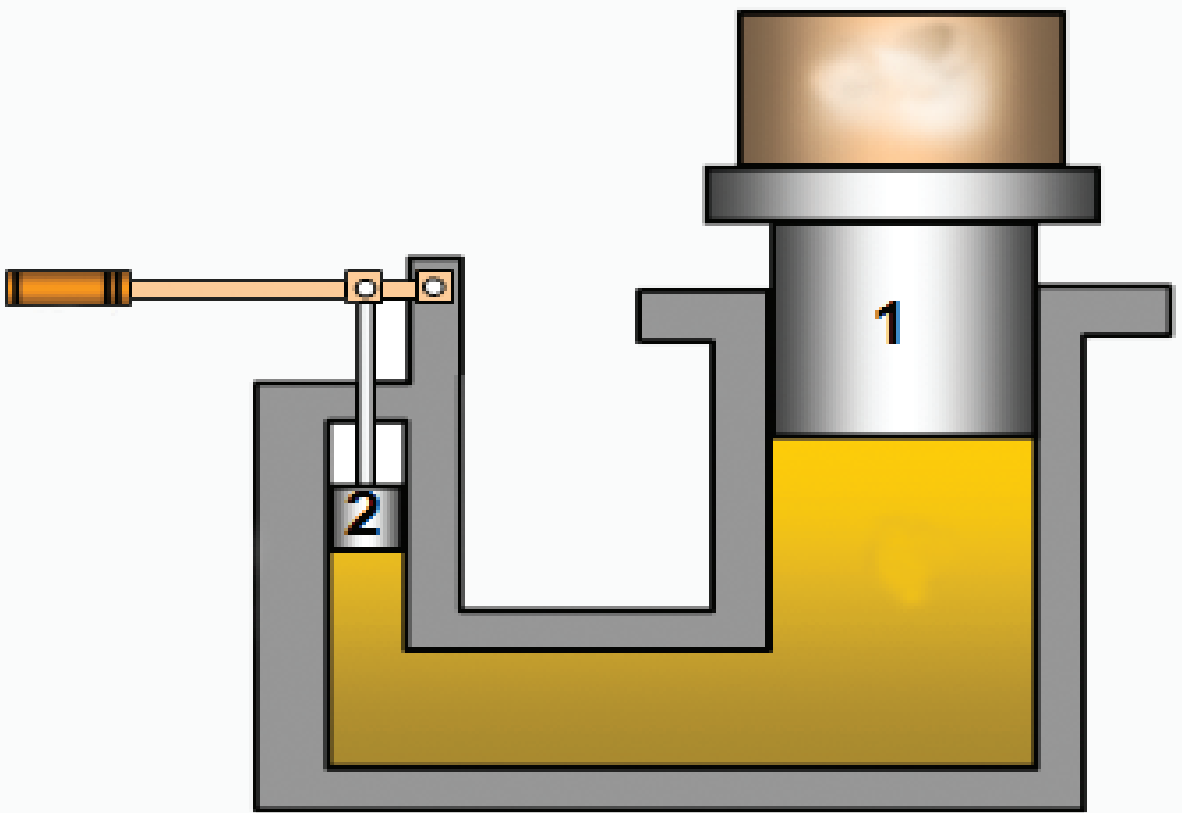

This Book is the Property of the  
Ministry of General Education  
and Instruction.

This Book is not for sale.

Funded by:



## **How to take care of your books.**

### **Do's**

- 1. Please cover with plastic or paper. (old newspaper or magazines)**
- 2. Please make sure you have clean hands before you use your book.**
- 3. Always use a book marker do not fold the pages.**
- 4. If the book is damaged please repair it as quickly as possible.**
- 5. Be careful who you lend your schoolbook to.**
- 6. Please keep the book in a dry place.**
- 7. When you lose your book please report it immediately to your teacher.**

### **Don'ts**

- 1. Do not write on the book cover or inside pages.**
- 2. Do not cut pictures out of the book.**
- 3. Do not tear pages out of the book.**
- 4. Do not leave the book open and face down.**
- 5. Do not use pens, pencils or something thick as a book mark.**
- 6. Do not force your book into your schoolbag when it is full.**
- 7. Do not use your book as an umbrella for the sun or rain.**
- 8. Do not use your book as a seat.**

South Sudan

SECONDARY

1

# Physics

## Student's Book 1



This book is the property of the Ministry of General Education and Instruction.

**THIS BOOK IS NOT FOR SALE**

Funded by:



GLOBAL  
PARTNERSHIP  
for EDUCATION

quality education for all children

Published in 2018 by:  
Longhorn Publishers (K) Ltd.,  
Funzi Road, Industrial Area,  
P.O. Box 18033 – 00500,  
Nairobi, Kenya.

©2018, THE REPUBLIC OF SOUTH SUDAN, MINISTRY OF GENERAL  
EDUCATION AND INSTRUCTION.

All rights reserved. No part of this book may be reproduced by any means  
graphic, electronic, mechanical, photocopying, taping, storage and retrieval  
system without prior written permission of the Copyright Holder.

Pictures, illustrations and links to third party websites are provided  
in good faith, for information and education purposes only.



## Contents

<b>States of matter .....</b>	<b>1</b>
1.1 Matter and its composition .....	2
1.2 Introduction to kinetic theory .....	4
1.3 Physical properties of matter .....	6
1.4 Movement of particles in matter.....	13
1.5 Application of cohesive and adhesive forces between molecules .	18
1.6 Surface tension.....	22
<b>Topic summary and new words .....</b>	<b>28</b>
<b>Topic Test 1 .....</b>	<b>28</b>
<b>Types of forces and their measurement .....</b>	<b>29</b>
2.1 Definition of force .....	30
2.2 Effects of forces .....	32
2.3 Measurement of force .....	35
2.4 Representation of forces using vector diagrams .....	37
2.5 Combination of forces .....	38
2.6 Types of forces .....	46
2.7 Weight and mass.....	66
<b>Topic summary .....</b>	<b>70</b>
<b>Topic Test 2 .....</b>	<b>71</b>
<b>Pressure .....</b>	<b>74</b>
3.1 Force acting on a surface .....	74
3.2 Definition of unit of pressure .....	75
3.3 Pressure in solids.....	76
3.4 Pressure in liquids .....	81
3.5 Pressure in gases.....	87
3.6 Transmission of pressure in fluids.....	88
3.7 Application of Pascal's principle .....	91

3.8	Atmospheric pressure .....	93
	<b>Topic summary .....</b>	<b>101</b>
	<b>Topic Test 3 .....</b>	<b>102</b>
<b>Effects of temperature changes on matter .....</b>		<b>105</b>
4.1	Heat as a form of energy .....	107
4.2	Temperature scales .....	107
4.3	Thermal equilibrium .....	113
4.4	Measurement of temperature .....	114
4.5	Types of thermometers .....	116
4.6	Calibration of thermometers .....	121
4.7	Effects of temperature change on solids .....	125
4.8	Effect of temperature change in liquids .....	128
4.9	Evaporation.....	137
4.10	Sublimation and deposition .....	139
	<b>Topic summary .....</b>	<b>143</b>
	<b>Topic Test 4 .....</b>	<b>143</b>
<b>Reflection of light on plane surfaces.....</b>		<b>145</b>
5.1	Nature of light.....	146
5.2	Rays and beams.....	148
5.3	Rectilinear propagation of light .....	150
5.4	Formation of shadows and eclipses .....	151
5.4	Pinhole camera.....	156
5.5	Reflection of light at plane surfaces .....	161
5.6	Image formation by a plane mirror .....	166
5.7	Applications of reflection at plane surfaces.....	177
5.8	Project work .....	179
	<b>Topic summary .....</b>	<b>181</b>
	<b>Topic Test 5 .....</b>	<b>182</b>

<b>Behavior of light at plane surfaces .....</b>	<b>185</b>
6.1 Phenomena of refraction of light .....	185
6.2 Refraction of light through a prism .....	208
<b>Unit summary .....</b>	<b>219</b>
<b>Topic Test 6 .....</b>	<b>220</b>
<b>Electricity .....</b>	<b>225</b>
7.1 Types of electrostatic charges .....	226
7.2 The law of electrostatics .....	228
7.3 Conductors and insulators .....	230
7.4 Effects and application of electrostatics .....	232
<b>Topic summary .....</b>	<b>233</b>
<b>Topic Test 7 .....</b>	<b>234</b>
<b>Introduction to current Electricity .....</b>	<b>235</b>
8.1 Simple electric circuit and its components .....	235
8.2 Arrangement of bulbs and cells in an electric circuit .....	237
8.3 Electric current .....	243
8.4 Potential difference (p.d) .....	250
8.5 Chemical cells .....	255
8.6 Project work .....	264
<b>Topic summary .....</b>	<b>265</b>
<b>Topic Test 8 .....</b>	<b>265</b>



**Topics in the unit****Topic 1: States of matter****Learning outcomes****Knowledge and Understanding**

- Understand that matter can exist in different states

**Skills**

- Perform tests to investigate surface tension, osmosis and capillarity of fluids.
- Predict what might happen based on the particle theory
- Use appropriate measures
- Collect and present results appropriately
- Interpret results accurately
- Report findings appropriately

**Attitudes**

- Show curiosity in carrying experiments.

**Key inquiry questions**

- How can we explain why matter exists in three states?
- How do the forces interact in matter?
- What causes the change of states of matter?
- How could we determine the viscosity of a certain fluid in the lab?
- What causes surface tension?

**Topic outline** ▶▶▶

- Describe the composition of matter.
- Simple kinetic theory.
- Evidence that matter is made up of small particles.
- Physical properties of solids.
- Physical properties of liquids.
- Physical properties of gases.
- Applications of physical properties of matter.
- Recognition of physical properties of matter.

**Introduction**

Matter is anything and everything that we come across in this world. Matter can be a piece of rock, a grain of maize, a piece of paper, water or air which we breath. In science ‘matter’ is defined as anything that occupies space and has mass. Matter can be classified into three states namely *solids, liquids and gases*.

**1.1 Matter and its composition****Activity 1.1****To describe matter**

(Work in pairs)

**Steps**

From your knowledge of science at the primary level:

1. *Discuss with your class partner the examples of matter you can see or feel around you.*
2. Compare and discuss your answers with other pairs in your class.
3. Take turns in a class discussion to present difference between solids, liquids and gases.

As you learnt in your primary science, matter is anything that has weight and occupies space. Anything around us is matter. But what is matter made up of? Activity 1.2 will help us to understand this.

## Activity 1.2

### To investigate composition of matter

(Work in pairs)

**Materials:** a piece of chalk, a piece of paper

#### Steps

1. Get a piece of chalk and a piece of paper.
2. Let one of you break the chalk and continue breaking until you cannot break it any further. What do you notice about the initial piece and the final particle in terms of size? Is the smallest size you have obtained the smallest possible?
3. Let your partner get the piece of paper and cut it into two halves.
4. Continue cutting the paper into smaller pieces until you cannot cut it anymore.
5. Discuss your observations in step 2 and 4 with your colleagues.
6. Discuss with your colleague what you remember about an element, compound and mixture from what you learnt in primary 4.
7. Discuss the different methods used to separate mixtures. Are the methods you have discussed possible to separate all mixtures? Explain why?

If you break a piece of chalk or paper, it will keep reducing to smaller particles. If you could be able to keep on breaking the pieces you could arrive at the smallest particles of matter that can be separated by physical means. These smallest particle of matter that cannot be broken down further by physical means is called an **atom**. An atom is the smallest particle of matter that can take part in a chemical reaction. There are other smaller sub-atomic particles that are covered in other units.

Matter can be made of particles (atoms) of the same kind or a group of particles of different kinds. Matter is made of an **element, mixture or a compound**.

**An element** is a substance which cannot be splitted into a simpler substance. In other words, all the atoms in a substance have the same identity that substance is called an element e.g. copper, graphite in pencil (carbon).

**A compound** is a substance made of two or more elements combined together in a fixed proportion. E.g. water is made up of oxygen and hydrogen, table salt is made of sodium and chloride, chalk is made up of calcium carbonate, that is, calcium, oxygen, and carbon.

**A mixture** is a material made up of two or more substances that can easily be separated by physical means. e.g. salt and sand, iron and sulphur.

Fig 1.1 illustrates the difference between a compound, an element and a mixture.

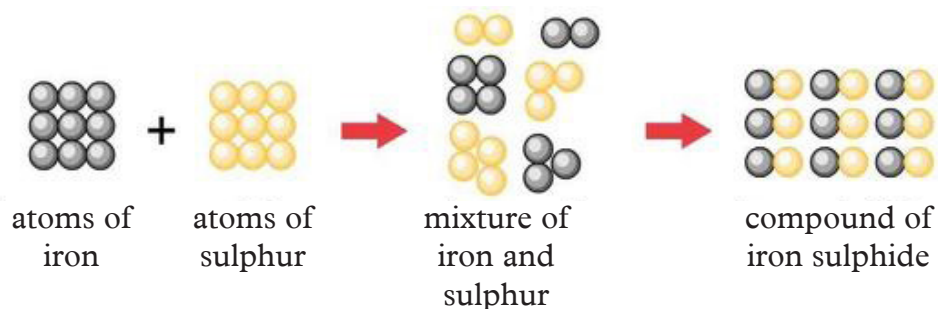

Fig 1.1 Iron and sulphur

### Warning



Atoms may be small in size, but can be used to cause mass destruction through nuclear and atomic bombs. **SAY NO TO WAR AS IT CAUSES A LOT OF DESTRUCTION.**

## 1.2 Introduction to kinetic theory of matter

### Activity 1.3

(Work in groups)

To differentiate between physical and chemical properties of matter

#### Materials

- two beakers
- water
- purple crystals of potassium permanganate
- bunsen burner
- perfume
- straw

#### Steps

1. Get a beaker and pour in water up to more than half its height and leave it to settle.
2. Get the crystals of potassium permanganate and drop them through the straw into the bottom of the beaker of water. What makes the colour of potassium permanganate spread?
3. What do you think would happen if you added the crystals of potassium permanganate into the water before it settled?
4. Repeat step 2 but this time heat the beaker gently. Compare your observations with that in step 2. How fast does the colour spread?
5. Stand in a row, from the front of the class to the back. Let the one in the front spray a perfume. Let each learner in the row raise his hand whenever he smells the spray. Do you all smell the perfume at the same time? In what pattern do you raise your hands? What do you think will cause the rate at which the spray spreads to change?



6. Discuss your observations in steps 2, 3 and 4 with other groups in class and use your conclusion to state the kinetic theory of matter.

When a perfume is sprayed in one corner, it is smelt in the other corner because the particles of the perfume have moved from one point to the other. This shows that matter is made of particles that are constantly moving. If matter particles were not moving, then there could be nothing that could move about and mix with the water. The movement of these tiny particles is summed up in a model called the **kinetic theory of matter**.

The kinetic theory makes the following assumptions.

1. Matter consists of small particles.  
All matter is made up of a large number of tiny particles either individual atoms or molecules.
2. Large separation between particles.  
The second assumption describes the separation of the particles.
3. Particles are in constant motion.  
The third assumption is that each particle in matter is in constant motion.

### **The kinetic theory of matter**

The word kinetic is derived from the Greek word “*kineo*” which means “I move”. Particles in substance are in constant motion; they possess kinetic energy, which is the energy due to movement. Therefore, kinetic theory of matter states that **matter is made up of tiny particles that are continuously in random motion**. It says that the materials particles have greater kinetic energy and are moving faster at higher temperatures.

When a fast moving particle collides with a slower moving particle, it transfers some of its energy to the latter, increasing the speed of that particle. If that particle collides with another particle that is moving faster, its speed will be increased even more. But if it then hits a slow moving particle, then it will speed up the third particle while its speed decreases.

The theory explains how particles are packed in solids, liquids or gasses; the attractive forces between them; and the effect of temperature on them. The arrangement of particles in matter and the way they move determines the state of a substance, i.e. whether to be in solid, liquid or gaseous state.

#### **Note!**



One important fact explained by the kinetic theory is that the average molecular kinetic energy is proportional to the absolute temperature of the material. Such temperature is a measure of the average internal kinetic energy of an object.

## 1.3 Physical properties of matter

### 1.3.1 Solids

#### Activity 1.4

#### To investigate physical properties of solids

(Work in groups)

#### Materials

- Internet
- Reference books
- Sand
- Solids of different shapes
- Marbles and a transparent square bowl
- Empty container

#### Steps

1. Access the Internet or reference books and do a research on the physical properties of solids and their application. Discuss your findings in your group.
2. Now, put as many marbles into a transparent square bowl as you can. Incline the bowl a bit.
3. Continue adding more marbles into the bowl as many as possible.
4. Cover the bowl with a lid and note the pattern (arrangement) of marbles inside it.
5. Assuming the shape taken by the marbles in the fully parked container illustrates the arrangement of particles in solids, draw the arrangement of particles in solids.
6. Fill the bowl fully with the marble and cover it tightly with a lid. Try to shake the bowl while pressing the lid firmly. Do the marbles move easily? Explain the effect on their pattern of arrangement and the movement to your partner.
7. Pour out all the marbles from the bowl and fill it with sand. Cover it tightly with a lid. What can you note about number of sand particles and the number of marbles that fit into the container. Between the two which one are more packed? Use your conclusion to explain density in solids.
8. Take the solids of different shapes i.e. cubes, cuboid and cylinders (see fig. 1.2).

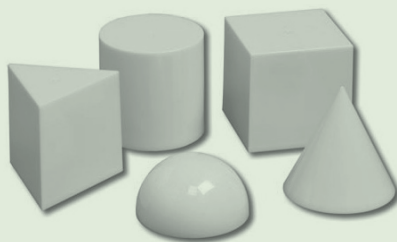
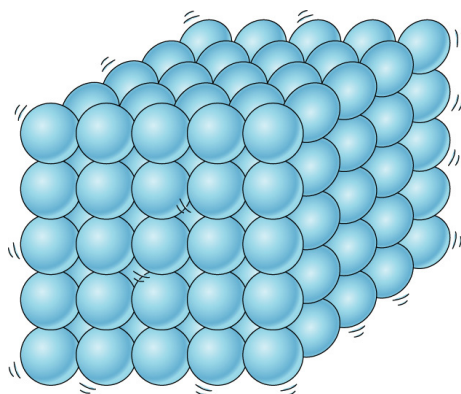

Fig. 1.2

9. Now put each of the solids you have into an empty container. Does their shape change? What can you conclude about the shape of solids?

The particles in a solid are so tightly packed making them difficult to move. Solids have strong intermolecular forces between the particles making the particles to be closely packed in fixed positions (rigidity).



*Fig 1.3 Arrangement of particles in solids*

Solids have a definite shape and volume. They are rigid and incompressible. They have the **highest density** compared to liquids and gases.

A large force is needed to change the size and shape of a solid. Also, for a solid to melt into a liquid, it requires a lot of heat energy since the cohesive forces between the particles are strong.

Particles or molecules in a solid are continuously vibrating in a fixed or mean position. When a solid is heated, the heat energy absorbed by the particles increases the kinetic energy; this makes the particles to vibrate more vigorously but in their fixed positions.

When the temperature of a solid is increased, it undergoes **thermal expansion**. This happens because the mass of the solid stays the same but its **volume increases**. This results to **decrease in density**. When cooled down, solids undergo **thermal contraction** decreasing in volume and thus their **density increases**.

Increase in heat energy increases the kinetic energy in the particles and weakens the cohesive forces between the molecules up to a point when the intermolecular forces are weak to allow the matter to flow. This point is referred to as melting point. The process of a solid changing into a liquid is called **melting**.

### 1.3.2 Liquids

#### Activity 1.5

#### To investigate physical properties of liquids

(Work in groups)

#### Materials

- Water in a beaker
- Bunsen burner
- Chalk dust

#### Steps

1. Put the chalk dust on the surface of the water in the beaker. Observe and explain the motion of the chalk particles.
2. Now, start heating the water to boil. Observe and explain the motion of the chalk particles. Does the motion change? What causes this change?
3. Draw the arrangement of particles in liquids. Compare and discuss your findings with other groups in your class.

When dust particles in water are observed, they are seen moving in a random manner. Tiny invisible water molecules, moving in different directions at different speeds, collide with the chalk dust particles and force them to move. This activity suggests that the invisible, tiny molecules of water are in a constant random motion.

As seen in Activity 1.5, the liquid molecules move freely, unlike the molecules in a solid. The distance between the molecules is slightly greater than the distance between molecules of a solid. The molecules of a liquid are loosely packed unlike those of the solid (Fig. 1.4).

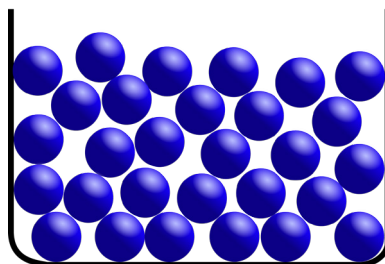

Fig 1.4: Arrangement of particles in liquids

#### Activity 1.6

#### To investigate the shape of liquids

(Work in groups)

#### Materials

- A 250 ml beaker
- A 250 ml round bottom flask
- Water

## Steps

1. Take a 250ml beaker and fill it with water. Note the shape taken by the water.
2. Pour the water from the beaker in step 1 into a 250ml round-bottom flask see Fig. 1.5.



(a) Beaker



(b) Round bottom flask

Fig. 1.5

3. What shape does the liquid take? Why do you think the water takes the different shapes?

Though liquids have definite size (volume), they have no particular shape. They take the shape of the container.

Liquids expand when their temperatures increase. Increasing of temperature decreases the density of water.

When the temperature increases, liquid molecules acquire more kinetic energy and hence move faster. This increase in kinetic energy of liquid molecules weakens the intermolecular forces between the particles. A further increase in kinetic energy makes the molecules to escape through the surface of the liquid. i.e., change into steam or gaseous state. The process of a liquid changing into the gaseous state is called **evaporation**.

### 1.3.2.1 Boiling point

#### Activity 1.7

#### To investigate boiling of water

(Work in groups)

#### Materials

- Beaker
- water
- source of heat
- tripod stand
- wire gauze
- stirrer
- thermometer

## Steps

1. Put some water into the beaker. Dip the stirrer and thermometer into the beaker. Record the temperature. Why do you think it is advisable to keep stirring the water?
2. Place the beaker and its content onto the stand and place the source of heat below it as shown in Fig. 1.6.

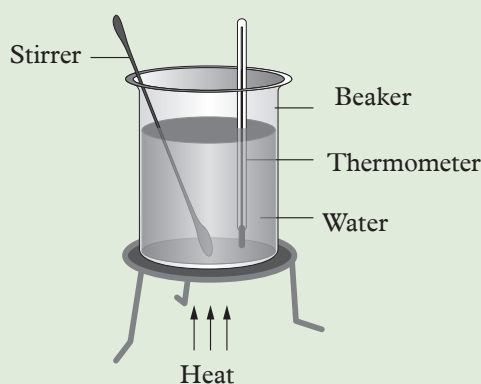

Fig 1.6: Boiling water

3. Continue heating the water as you observe the change in temperature.
4. The temperature reaches a point when the water will start boiling vigorously. Record the temperature. What is the name of this process? What do you think happens to the temperature of water as the water boils vigorously?
5. During this process is there a change in the temperature of the water? Try explaining what is happening to the molecules of water during this process.

Boiling point is the temperature at which a liquid changes into a gas when the saturated vapor pressure of the liquid is equal to the external atmospheric pressure under one atmosphere. At this point, the liquid changes to gaseous state at constant temperature. Different liquids have different boiling points.

### 1.3.3 Gases

#### Activity 1.8

To investigate the physical properties of gases

(Work in groups)

#### Materials

- Three marbles
- transparent dish
- a lid
- reference books
- Internet

### Steps

1. Access the internet and reference books and do research on the physical properties of gases. Discuss your findings with other groups in your class.
2. Now, put three marbles in a transparent dish. Try as much as you can to move them further away from one another.
3. Cover the dish with a lid. Shake the dish. In what direction do the marbles move?
4. Relate the movement of the marbles and the movement of air particles. Why do you think the air molecules are able to make such movement?

When few marbles are put in a container and shaken they move freely in all directions in the dish. This is similar to the behaviour of particles in a gas.

In gases, the intermolecular forces are so weak to be considered. Weak intermolecular forces only exist upon collision. A gas has no definite shape and volume, so they spread fill the container of any size and shape completely.

### Activity 1.9

#### To demonstrate that gases occupies space

(Work in groups)

#### Materials

- Polythene bag ( plastic bag)
- A straw
- Cello tape
- Heavy book.

#### Steps

1. In groups of five, pick one plastic bag (polythene bag) and insert a straw into it. Leave part of the straw to protrude from the bag and then seal it with cello tape.
2. Place it on the table and then place a heavy book on it.
3. In turns, blow air into the bag. What do you think is the impact of the book as you blow? What do you observe? Explain your observation.
4. In turns, sketch the arrangement that you think the air molecules take. Give a reason for the shape you have sketched.

### CAUTION



The material making up, plastic bags (polythene bags) determine, how easily it can be recycled. Some plastics can take years to decompose. But some companies and stores have begun using different types of biodegradable bags to avoid environmental pollution. If poorly disposed plastic pollutes the environment and can easily be ingested by livestock and wild animals thus posing a danger to them.

### Activity 1.10

### To investigate the shape of gases

(Work in groups)

#### Materials

- Solid carbon dioxide
- A 250ml beaker
- A glass lid
- A tumbler

#### Steps

1. Place solid carbon dioxide at one of the bottom corner of a beaker covered with a glass lid. What happens to the solid carbon dioxide?
2. Place a tumbler that has a mouth the same size as the beaker on top of glass cover.
3. Remove the glass cover (see fig. 1.7). What happens to the fumes of carbon dioxide? What do you think causes the observation you have made?

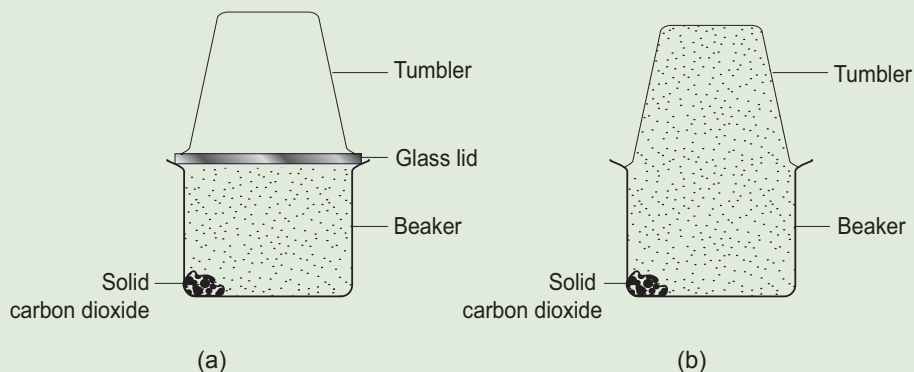

Fig. 1.7

4. Do you think you will make the same observation if bigger tumblers were used?

When air is blown into a polythene bag, it is seen to bulge and become inflated. This is because the number of gas molecules increased in the bag as one blew into it. This demonstrates that gases occupy space. Fig 1.8 shows the arrangement of gas particles.

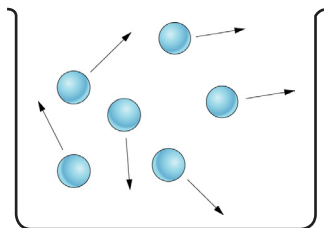

Fig. 1.8 Arrangement of gas particles



The distance between the molecules is large (see Fig 1.7) and the force of attraction between the molecules is very small (almost negligible). These molecules move about freely in all directions colliding with each other and with the walls of the container. The movement of molecules from a region of higher concentration to a region of lower concentration is called **diffusion**.

From Activity 1.10 gases can diffuse into each other rapidly taking the shape of the container, this is because gases are light (less dense) compared to solid and liquid. This best explains what we learnt in activity 1.3 that when a gas is sprayed in one corner of the room, it spreads throughout the room. Gas particles are also smaller.

Gases are compressible (they can be squeezed) into a small volume, like in a car tyres and bicycle tyres when pumped. This is because they have spaces in between them (Fig 1.8).

## 1.4 Movement of particles in matter

### 1.4.1 Viscosity

#### Activity 1.11

#### To demonstrate viscosity in liquids

(Work in groups)

#### Materials

- House hold liquids (water, honey, oil, milk, paraffin)
- A sphere such as a steel ball
- Ruler
- 100 ml graduated cylinders
- Stopwatch.

#### Steps

1. Measure equal amounts of water, honey, oil, milk and paraffin and pour them into different the graduated cylinders. What do you note about them? How is the flow of different liquids as you pour them into the cylinders?
2. Measure and record the depth of the liquids in the cylinders.
3. Place the sphere on the surface of water. Using a stopwatch, measure and record how long it takes for it to flow to the bottom of the liquid.
4. Remove the sphere and repeat step 3, two times for the same liquid. What do you observe?
5. Rinse and dry the sphere. Repeat steps 3,4 and 5 for the rest of the liquids. What do you observe? Explain your observation. What do you think makes the ball fall at different rates in the different liquids?

6. Tabulate your result in a table form as one shown in Table 1.1.

Substance	Trial	Depth of liquid (cm)	Time (s)	Speed (s)

Table 1.1: Table of results

7. In groups discuss and make notes on thickness of the liquids as illustrated by the steps 1-6.

Different liquids have different thickness thus having different ability to flow. The state of a liquid being thick and sticky due to internal friction is called viscosity. Fluids resist the relative motion of immersed objects through them as well as the motion of layers with differing velocities within them. The sphere moved fastest in water and lowest in honey. This shows that, water has the lowest viscosity as compared to other liquids since it offers minimum resistance to the movement of the sphere through it. Honey has the highest viscosity as compared to the other liquids.

### 1.4.2 Diffusion

Diffusion is the process in which the molecules of a fluid spread from regions of their higher concentration to regions of their lower concentration as we saw with the potassium permanganate crystals in activity 1.3.

#### Activity 1.12

#### To investigate diffusion in liquids

(Work in groups)

#### Materials

- A bottle
- A glass container
- Concentrated solution of potassium permanganate

#### Steps

1. Fill a bottle with a concentrated solution of potassium permanganate and leave the top open (Fig. 1.9(a)).
2. Place this bottle in a large glass container (Fig. 1.9(b)) and pour water carefully from the side till the water level is well above the open top of the bottle (Fig. 1.9(c)). Why do you think water should be above the bottle?

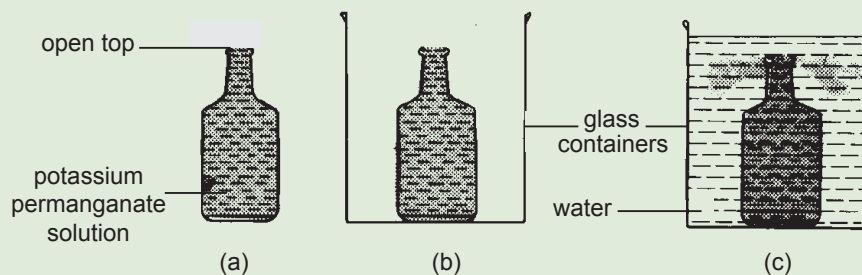

Fig. 1.9: Diffusion in liquids

3. Leave the set-up undisturbed for some time. Observe what happens to the colour of the solution inside the bottle and to the water outside surrounding the bottle. You may have to observe this for a long time.
4. What do you think would happen if the concentrated potassium permanganate was used in place of water?

The coloured solution of potassium permanganate rises upwards and spreads to the entire space occupied by the water.

The spreading continues in such a way that the molecules of the solution move from a region of *higher concentration* to a region of *lower concentration*. This is diffusion in liquids. The spreading stops when the concentration of the entire solution becomes the same all over.

Particles in liquids diffuse from one point to all other parts of the liquid.

### Activity 1.13

#### To demonstrate diffusion in gases

##### Part 1

(Work in groups)

##### Materials

- Two jars
- Carbon dioxide gas
- Blue litmus paper
- Two gas jars
- A glass plate

##### Steps

1. Take two jars, one filled with carbon dioxide gas and the other with air.
2. Introduce a wet blue litmus paper into these jars and observe what happens in each case. Explain the observation made in each case?

## Part 2

### Procedure

1. Take two jars, one filled with carbon dioxide gas and the other with air.
2. Stick a blue litmus paper at the bottom of the beaker filled with air.
3. Arrange the two jars with a glass plate separating them as shown in Fig. 1.10.
4. Leave the set-up undisturbed for a few minutes and then carefully remove the glass plate. Does the litmus paper change colour before you remove the glass plate?
5. What happens to the litmus paper when the glass plate is removed? Explain your observation when the glass plate is removed?

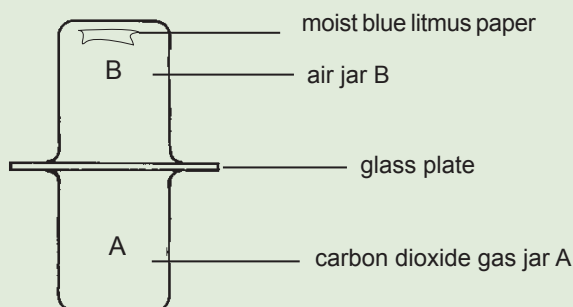

Fig. 1.10: Diffusion in gases

6. Design an experiment to investigate effect of using gases of different mass in diffusion.
7. In your investigation write down the procedure you have followed, the assumptions made and the relevant illustration of your investigation.
8. Derive the relevant formulae to illustrate the effect of using different gases in diffusion.

The blue litmus paper turns red in the jar containing carbon dioxide. It remains blue in the other jar. This is the test for the presence of carbon dioxide which will be used in part (b).

The blue litmus paper turns red in air jar B. The above effect shows the presence of carbon dioxide gas in the top jar, which contained only air. That is why blue litmus paper turns red.

As soon as the glass plate is removed, the dense molecules of carbon dioxide gas rise upwards and spreads to the region of air of low density. The molecules of the

two gases inter-mix with each other. The spreading continues until the mixture acquires a uniform density.

The observation shows that molecules in a gas move from a region of *higher concentration* to the region of *lower concentration*. This is diffusion in gases.

Diffusion in gases takes place more quickly than in liquids. The molecules of a gas move more freely than those of a liquid. This is the process by which volatile substances e.g. perfumes, spread through a room even when the air is perfectly still. In a solid, the molecules can only vibrate to and fro in their fixed positions.

It is important to note that the rate of diffusion of gases depend on its molecular weight. Thus if molecular weight of gas A is four times that of gas B, then gas A would diffuse at half the rate of gas B. This is best explained using Graham's law of diffusion which states that *the rate of diffusion of a gas is inversely proportional to the square root of the mass of its particles. The formula can be written as:*

$$\frac{\text{Rate A}}{\text{Rate B}} = \sqrt{\frac{M_B}{M_A}}$$

Where: Rate A is the rate of diffusion of the first gas.

Rate B is the rate of diffusion of second gas

$M_A$  is the molar mass of gas A.

$M_B$  is the molar mass of gas B.

### 1.4.3 Osmosis

#### Activity 1.14

#### To investigate osmosis in semi-permeable membrane

(Work in groups)

#### Materials

- Straw/Capillary tube
- String
- Salt solution
- Beaker with distilled water.
- Visking tube

#### Steps

1. Tie one side of the visking tube with a string.
2. Fill the tied visking tube with the salt solution.
3. Insert the straw into the visking tube and tie the visking tube around the straw. Note the level of the solution in the straw.
4. Deep the tied visking tube into the beaker containing distilled water. (see Fig 1. 11). Let it be in the water for few minutes.
5. What do you observe on the level of the solution in the capillary tube?

6. What happens to the level of water in the beaker? Explain what causes this change?
7. What do you think would happen if concentration of solution in both the beaker and the visking tubing was the same?

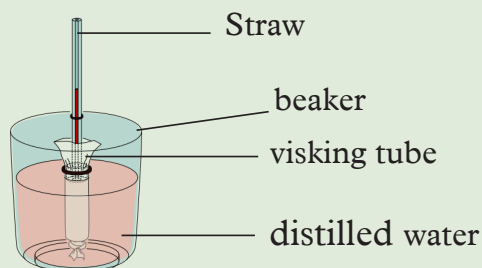

Fig 1.11: Osmosis in semi-permeable membrane

**Osmosis** is the process through which a solvent solution such as water moves through a semi-permeable membrane into a solution.

Osmosis can be described in terms of kinetic theory, that is more massive molecules diffuse slower than the less massive ones at a similar temperature.

A good example of osmosis is when an egg is put in a sugar solution. Water molecules pass through the semi-permeable shell into the egg. Sugar molecules that are bigger don't pass through.

## 1.5 Application of cohesive and adhesive forces between molecules

### 1.5.1 Cohesive and adhesive forces

Matter is made up of small particles called *molecules*. These particles are held together by force of attraction between them. The force of attraction between molecules of the same substance is called the *force of cohesion* (Fig. 1.12(a)).

The force of attraction between molecules of different substances is called the *force of adhesion* (Fig. 1.12(b)).

A free liquid drop is almost spherical. When a drop of water is placed on a glass plate, the glass molecules attract the water molecules strongly. The drop spreads out over the glass and hence its shape changes (Fig 1.12(b)).

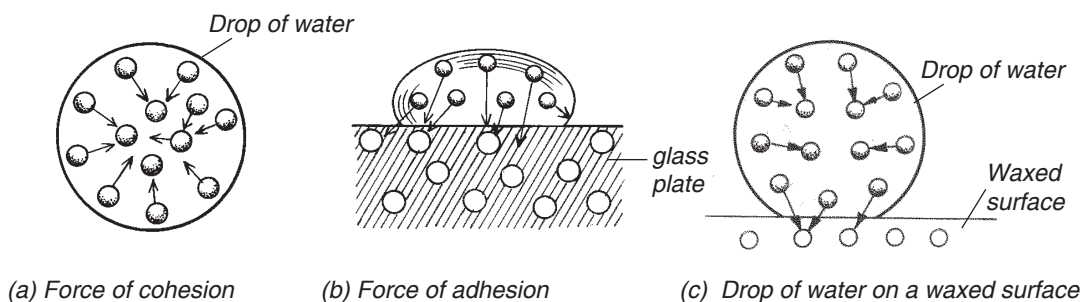

Fig. 1.12: Cohesive and adhesive forces

When a drop of water is placed on a waxed surface (Fig. 1.12(c)), the drop is almost spherical. The force of adhesion between water molecules and wax molecules is less than the force of cohesion between water molecules. (The shapes of the drops described above is true for small drops. The large ones tend to spread a bit more due to their heaviness).

The forces of cohesion and adhesion always exist in pairs whenever liquids are in contact with solids. Their effect on the liquid surface depends on which force is greater. The forces of cohesion and adhesion may be used to explain the liquid *meniscus* and the *capillary action*.

### Liquid meniscus

When liquids are poured into containers, their surfaces are curved. In the case of water, the curved surface forms a *concave shape* (Fig. 1.13(a)). This is because the adhesive force between water molecules and glass molecules is more than the force of cohesion between the water molecules. For mercury the shape is *convex* (Fig. 1.13(b)). This is because cohesive force between the mercury molecules is greater than the adhesive forces between mercury molecules and glass molecules.



Fig. 1.13: Liquid meniscus

## 1.5.2 Capillary action

When a glass tube with a narrow bore in its centre (capillary tube) is dipped in a liquid, the liquid level rises or drops depending on the liquid used. The rise or fall of a liquid level in a tube is caused by *capillary action*.

*Capillary action* can be defined as the ability of a liquid to rise or fall in narrow spaces due to the intermolecular forces between the liquid and surrounding solid surfaces.

### Activity 1.15

#### To demonstrate capillary action using capillary tubes

(Work in groups)

#### Materials

- Beaker containing mercury
- Beaker containing water
- Three long tubes of different diameters.

#### Steps

1. Observe as the teacher dips three long tubes, one of which is a capillary tube, open on both ends in a beaker containing water as shown in Fig. 1.14(a). Observe what happens to the level of water and the type of meniscus in the tubes.
2. What causes the different levels of meniscus?
3. Now observe as he removes the tubes from the beaker containing water, dry them and dip them in the beaker containing mercury as shown in Fig. 1.14(b).
4. Observe what happens to the level of mercury and the type of meniscus formed in the tubes. Give a reason for the difference in level of the meniscus.

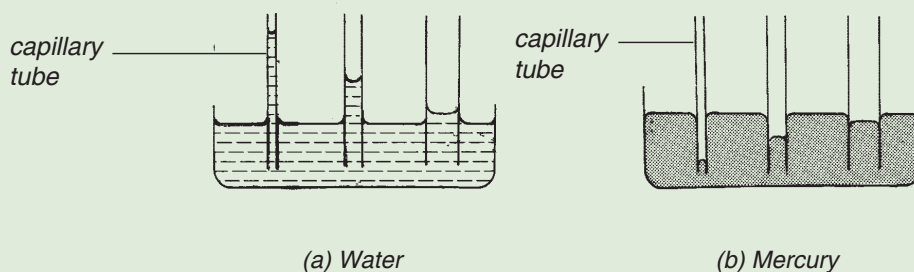

Fig. 1.14: Capillary action in water and mercury

The level of water rises in the tubes. The greatest rise is observed in the narrowest capillary tube (Fig. 1.14(a)). If mercury is used instead of water, the levels fall as shown in Fig. 1.14(b). The greatest fall is observed in the narrowest capillary tube.



### Activity 1.16

To demonstrate capillary action using chalk bricks.

#### Materials

- Two chalk bricks
- Shallow tray
- Waxed paper
- Coloured water

#### Steps

1. Pour a little coloured water into a shallow tray so that it submerges half of one of the chalk bricks (fig. 1.15(a)).
2. Place a second chalk brick on top of the first and observe what happens.
3. Repeat the steps 1 and 2 but with a piece of waxed paper between the two chalk bricks (fig. 1.15(b)). Why do you think a waxed paper was used?

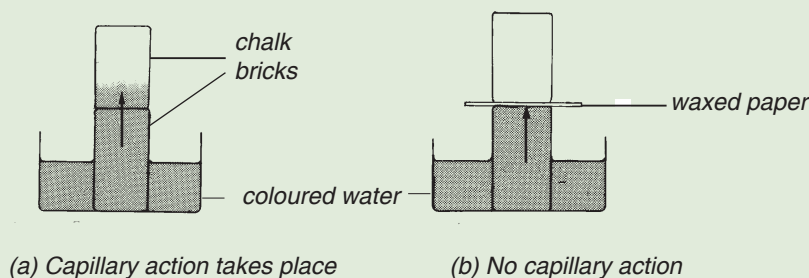

Fig 1.15: Capillary action on chalk bricks

4. Explain the forces that are leading to the observation made.

Chalk is a porous substance. The tiny air spaces in it form the capillary tube needed for the capillary action to take place. The coloured water rises up into the top brick (Fig. 1.15(a)). However, when waxed paper is used, Fig. 1.15(b), the adhesive force between the water molecules and the wax is small. The coloured water is therefore not able to cross over to the other chalk brick on top.

#### Applications of capillary action

Capillary action is applied in many situations. Here are some of the situations.

1. *The spreading of ink over a blotting paper:* The air spaces provide fine tubes.
2. *Kerosene rises up the wick of a lamp:* The fibres act like capillary tubes of fine bore.
3. *The rise of water from the soil in the plants:* Tissues of plants provide narrow tubes.
4. *Towels used for drying.* The air spaces in a towel provide fine tubes.

Capillary action might also become a nuisance. It causes dampness through the walls and floors of houses. To prevent this, a waterproof sheet of polythene is laid in the concrete base as shown in Fig. 1.16.

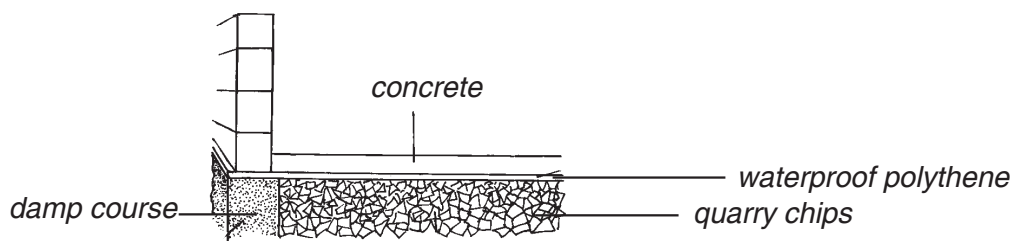

Fig. 1.16: Water proof material prevents dampness

## 1.6 Surface tension

### Activity 1.17

### To demonstrate surface tension

#### Materials

- Tissue paper
- Greased steel pin
- Water in a beaker

#### Steps

1. Place a tissue paper on the surface of clean water contained in a beaker. What happens to the tissue? Explain the observation.
2. Carefully place a greased steel pin on top of the tissue paper. Take care not to touch the water. Observe what happens (fig. 1.17). What do you think will happen if you touch the water. Explain.

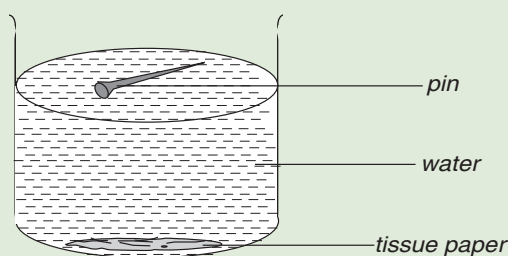

Fig.1.17: Surface tension

3. Put a drop of oil near the steel pin and observe what happens. Explain your observation. What is the effect of the drop of oil?

The tissue paper absorbs water and sinks to the bottom, leaving the steel pin *floating* on the surface of the water. How does the steel pin which is denser than water float? Use a hand lens to observe the surface under the steel pin. The surface of water behaves like a stretched, thin elastic skin that is under tension. The force that causes a liquid to behave this way is called *surface tension*.

When a drop of oil is put near the steel pin, it immediately sinks. The oil has reduced the surface tension of water which supported the steel pin and hence the pin sinks. This shows that surface tension of a liquid can be reduced by introducing impurities. Raising the temperature of the liquid also reduces surface tension.

Surface tension enables insects to walk on water surface. It provides a force which supports them.

**Activity 1.18** To show that a liquid will tend to have its surface as small as possible

**Materials**

- Funnel
- Liquid soap or detergent

**Steps**

1. Dip an inverted filter funnel in a liquid soap or detergent solution.
2. Take it out and blow a soap bubble on the wider end as shown in Fig. 1.18(a). Observe closely what happens to the bubble.

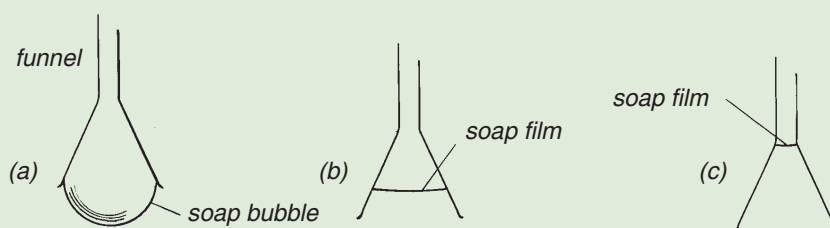

Fig. 1.18: Bubble moves up the funnel

The bubble flattens to a film and slowly moves up the funnel Fig. 1.18(b) until it reaches the narrowest end of the funnel Fig. 1.18(c). The soap film acts as an elastic skin in forming the soap bubble. By moving up it makes its surface as small as possible.

**Activity 1.19****To show surface tension in soap film.****Materials**

- Cotton wool
- Wire frame
- Liquid soap

**Steps**

1. Tie a loose loop of cotton thread onto the wire frame.
2. Slowly dip the wire frame into a liquid soap or detergent solution.
3. Withdraw it slowly so that a film is formed across the wire frame as shown in fig. 1.19(a). Break the film inside the loop and observe what happens.

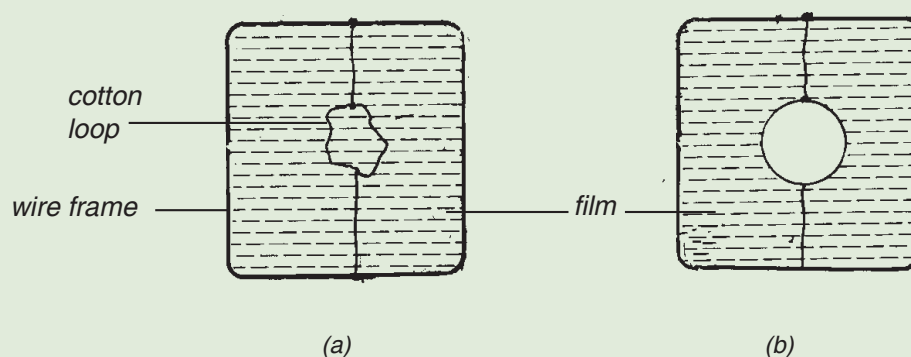

Fig. 1.19: Film on a wire loop

Once the film is broken from the inside of the loop, it forms a perfect circle (Fig. 1.19(b)). The film makes its surface as small as possible by pulling the thread into a circle.

**Activity 1.20****To show surface tension in clean water****Materials**

- Tumbler
- Dropper
- Water

**Steps**

1. Fill a tumbler with clean water (Fig. 1.20(a)).
2. Add a few more drops of water slowly in the tumbler as shown in Fig. 1.20(b). What happens to the water surface?

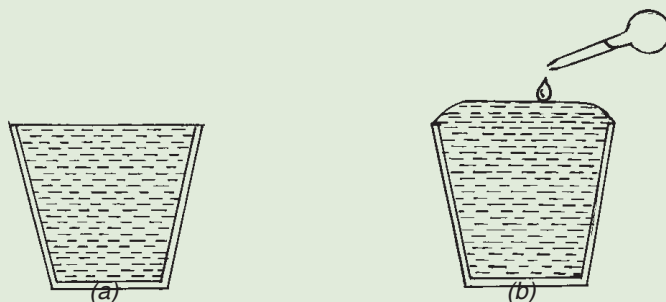

Fig. 1.20: Surface of water behaves like an elastic skin

The water forms a convex shape. The surface of the liquid behaves as if it were an elastic skin. However if more water is added the skin breaks and the water overflows.

### Surface tension of different liquids

Different liquids exhibit different surface tensions. e.g. water has a bigger surface tension than soap solution.

#### Activity 1.21

To show the effect of two tensions

#### Materials

- Matchstick
- Soap
- Water in a beaker

#### Steps

1. Apply some soap on one end of a matchstick.
2. Place the matchstick on water (Fig. 1.21). Does the matchstick move? In what direction does it move? What causes the movement?

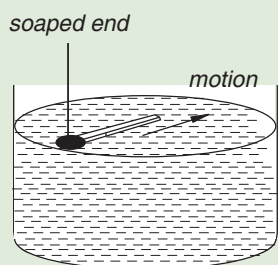

Fig 1.21: Effect of different surface tensions

The matchstick immediately starts to move in such a way that the soaped end is behind. The soaped end lowers the surface tension of water (soap dissolves and makes a soap solution). The other end being in a region of higher surface tension is pulled and moves in the direction shown.

### The cleaning power of a detergent

Place a drop of oil on the surface of clean water (Fig. 1.22). Observe what happens.

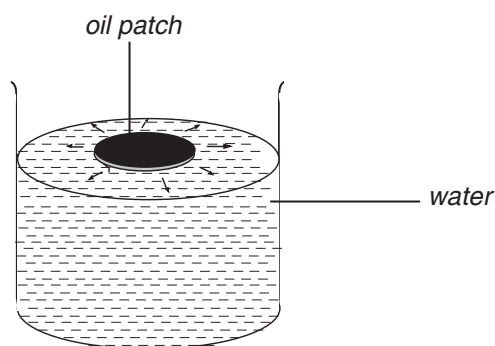

Fig. 1.22: Oil drop spreads into a circular patch

The surface tension of oil is less than that of water. Water pulls oil in all directions and spreads it in a thin circular patch.

Collect a few grains of detergent powder and drop them on the oil patch formed and observe. The oil patch breaks up and forms circles round each grain. The cleaning action of detergents depends on their ability to weaken the elastic skin. When it comes in contact with grease and dirt, it spreads into all corners and thoroughly wets the dirty objects instead of forming drops.

### Explaining surface tension

Molecules in a liquid attract each other (cohesion) (Fig. 1.23(a)). Molecules that are inside the liquid are attracted equally in all directions. The net force on a molecule inside a liquid is therefore zero (Fig. 1.23(b)). However molecules on the liquid surface have no molecules above them. The attractive force is therefore due to the molecules that are inside the liquid. Consequently the molecules on the surface layer experiences an *inward pull* from the molecules below them (Fig. 1.23(c)). The free surface of a liquid is therefore under tension which tends to stretch it.

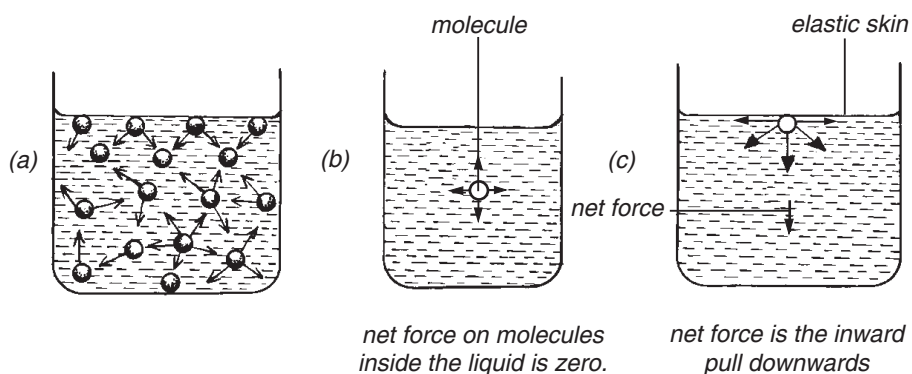

Fig. 1.23: Explaining surface tension

### Exercise 1.1

- Give scientific reasons for the following statements:
  - Water wets glass.
  - Mercury meniscus is convex.
  - Small drops of mercury form spherical drops when in contact with a clean glass plate.
  - Capillarity is more pronounced in very narrow bored glass tubes.
  - Towels are used to dry wet hands.
- The diagram in Fig. 1.24 shows a cracked drainage pipe. Explain the formation of the drops shown and how water is able to run along the underside of the pipe.

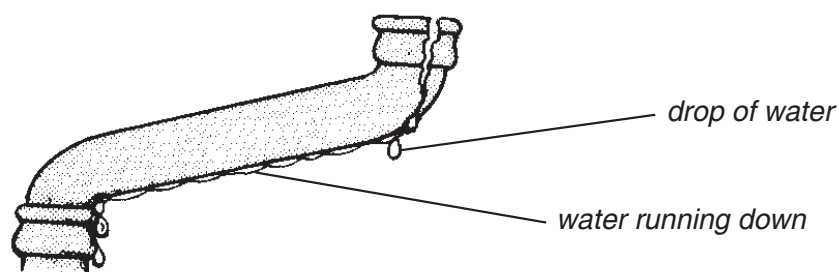

Fig. 1.24: A leaking drainage pipe

- Describe an experiment to explain surface tension in liquids.

### Topic summary

- Matter is anything that has mass and occupies space.
- Kinetic theory of matter states that matter is made up of tiny particles that are in constant random motion.
- Matter can be classified into three states: solids, liquids and gases.
- A gas has neither definite volume nor shape. Its molecules are free to move randomly.
- Solids have definite volume and shape. The molecules of solids are closely packed hence they just vibrate to and fro about their fixed positions.
- Liquids molecules move freely inside the container. Liquids take the shape of the container vessels. They have definite volume.
- Melting is the process by which a solid is converted to a liquid at a constant temperature.
- Viscosity is a measure of how much a fluid resists movement of objects through it.
- Gases are compressible because they have molecular spaces in between them.

### Topic Test 1

1. Explain why the density of a gas is much less than that of a solid or a liquid.
2. Draw a diagram to show how air molecule moves in a closed container.
3. Explain why it is easier to compress a gas than a liquid or a solid?
4. State one similarity between particles of a liquid and those of a gas.
5. Describe the difference between solids, liquids, and gases in terms of the arrangement of the molecules throughout the bulk of the material.
6. Explain why tyres burst when left outside during hot weather?
7. According to the kinetic theory, what is temperature?
8. State and explain two applications of physical properties of solids, liquids and gases and show how they have improved our lives.



## Topics in the unit

Topic 2: Introduction to forces

Topic 3: Pressure

## Learning outcomes

### Knowledge and Understanding

- Understand the types of forces and their measurement.

### Skills

- Carry out practical investigations using meters into the effect of friction and pressure
- Use appropriate measures
- Collect and present results appropriately
- Interpret results accurately
- Report findings appropriately

### Attitudes

- Show curiosity in carrying experiments.

### Key inquiry questions

- How do we classify forces?
- How can we distinguish between weight and mass of a body?
- Why are frictional forces important to an object?

**Topic outlines** >>>

- Definition of force.
- Types of forces and differentiate between contact and non-contact forces.
- Effects of forces.
- Representation of forces using vector diagrams.
- Measurement of forces.
- Weight and mass.
- Combination of forces.

**2.1 Definition of force**

In our daily lives, it is common to see things being pushed or pulled. Activity 2.1 gives us some of the instances where things are either being pulled or pushed.

**Activity 2.1****Demonstration of force**

(Work in pairs)

**Materials**

- Charts
- A stone
- Rope
- Classroom table

**Steps**

1. Push a table in your classroom slightly to displace it. Take care not to damage the legs of the table due to dragging.
2. Tie a stone or brick using a rope and pull it to other positions. (Take care not to be hurt by the stone). What will you notice if you used a bigger stone?
3. Now, study the pictures shown in Fig 2.2 and discuss with your class partner what is happening in each of them.

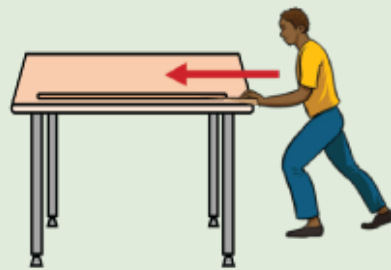

Fig. 2.1 : Pushing a table



(a)



(b)



(c)



(d)

Fig. 2.2 : Pushing or pulling objects

4. Tell your partner where a push or a pull is occurring.
5. Discuss with your partner other examples where a push or a pull occurs in our daily lives. List them down in your exercise book.
6. Compare and discuss your findings with different groups in your class.

These activities and many more involve either pushing or pulling. In physics, a pull or a push is called a **force**. Force is an action that causes the motion of an object in its direction of application or causes an object to change shape. However not all forces causes bodies to move.

The SI unit of force is the **newton (N)**, named after the famous physicist **Sir Isaac Newton** (1642 –1727).

Force is a **vector quantity**. It has both magnitude and direction. The magnitude is represented by a straight line while the direction is shown using an arrow as shown in Fig 2.3.



Fig. 2.3: Force exerted to the right

## 2.2 Effects of forces

The effect of a force depends on the size, nature, how and where the force is applied. The following activities illustrate the effect of forces on bodies.

### Activity 2.2

#### To demonstrate the effect of a force on objects

(Work in groups)

#### Materials

- A chart showing the different pictures

#### Steps

1. Look at the pictures in Fig 2.4.
2. Identify the effects of forces shown in the figures.



(a) Catching a moving ball



(b) Spiking a volleyball



(d) Cars colliding.



(e) A girl sitting on a balloon.

Fig. 2.4: Effects of forces

3. Discuss other cases where the effects you have identified in step 1 are also experienced.
4. What do you think will happen if the amount of force in each picture was increased?

A force can make a body at rest to start moving or a moving body to come to rest. It can also change the direction of motion of a body. Therefore, force can **change the state of motion of a body**.

A force can **distort or change the shape** of an object. For example, stretching a rubber band or a spring when compressed by a force and squeezing a balloon. Clay and plasticine are also other examples of substances whose shapes change easily when a force acts on them.

A force due to an earthquake can also cause massive destruction such as death of people and animals. It can also cause land deformation which leads to soil erosion and consequently contribute to pollution.

### Activity 2.3

**To show that force produces a turning effect on an object**

(Work in pairs)

#### Materials

- A seesaw
- A bottle opener
- Unopened bottle

#### Steps

1. With your partner, try to balance on a seesaw (Fig. 2.5(a)). Now try to lift your partner on the seesaw. What do you observe? How can you balance on the seesaw?
2. Observe the activity in Fig. 2.5 (b).

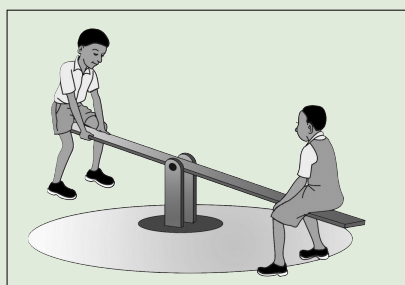

(a) Seesaw

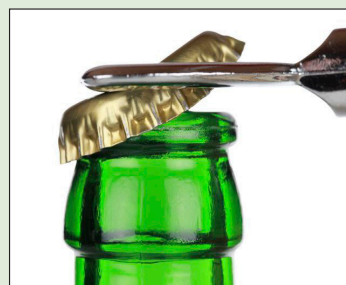

(b) A bottle opener

Fig. 2.5: Forces causing turning and rotation

3. Discuss with your class partner the effects of force shown in Fig. 2.5(b).

When forces are suitably applied can make a body to **turn about a point or cause a rotation**.

## Activity 2.4

### To demonstrate tear and wear as caused by force

#### Materials

- Different tyres

#### Steps

1. Take a close look at different tyres of vehicles within the school compound or roadside. What can you comment about their treads? Suggest a reason for their appearance.
2. Now, compare and discuss the state and condition of the tyres shown in Fig. 2.6.



(a) (b)

Fig. 2.6: Conditions of tyres

3. Name the effect of the force demonstrated in Fig 2.6 (b). Explain how the effect demonstrated is brought about by force.

The tyres wear and sometimes tear because of friction between the road and the tyre when in use. This shows that, forces can cause **wear** and **tear**.

In summary, the following are the effects of forces:

- Force can cause change in the state of motion of a body, i.e. force can start, stop, increase or reduce motion and change the direction of a body in motion.
- Force can change the shape of a body i.e. force can distort, stretch or compress a body.
- Force can cause turning effect. Examples are a seesaw and a beam balance.
- Force can cause rotation in the bodies e.g a steering wheel.
- Force can cause heating effect, i.e. frictional force cause heating, e.g. lighting a matchstick.
- Frictional force causes noise when rough surfaces are rubbed together.

## 2.3 Measurement of force

### Activity 2.5

To determine the force of an object using a force meter

#### Materials

- Force meter
- Masking tape
- Unknown masses of between 0.5kg and 1.0 kg

#### Steps

1. Using the masking tape cover the scale of the force meter to have a blank strip along the scale.
2. Hold the force meter vertically without any mass on the hanger. Make a mark on the blank strip of the force meter and that will be the 0 mark of your force meter scale.
3. Hang a 100 g mass from the force meter (100 g is equivalent to 1 newton). This force stretches the spring. Make a mark on the blank strip that will be the 1 newton of the scale.
4. Add another 100 g mass to the force meter. The force pulling the spring of the force meter now becomes approximately 2 newtons. Make 2 newton mark on your force meter scale.
5. Repeat step 3 up to 10 newtons mark. You have now ‘calibrated’ your force meter so that it has a scale for taking measurements.
6. Take the masses off the force meter and hang the unknown mass from it. Record the approximated force that acts on this mass.

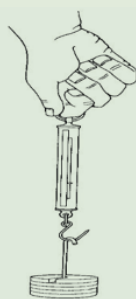

Fig 2.7. sketch of mass on a force meter.

7. Now remove the making tape from the force meter scale and repeat step 6. Record the force that acts on the different masses. What is the difference between the approximated force and the accurate force?

## Activity 2.6

### To determine your own strength

(Work in pairs)

#### Materials

- Spring balance
- Wall/ Rigid support

#### Steps

1. Hook the spring balance onto the wall.
2. Pull the other end of the spring as shown in fig 2.8.

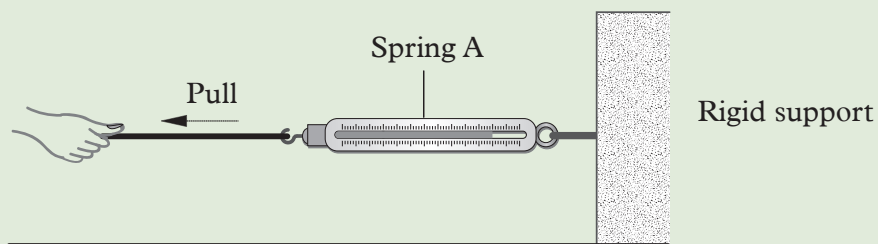

Fig 2.8 Measuring force

3. Let your partner read and record the reading on the spring
4. Exchange roles with your partner. What is the difference between your strengths?

Forces can be measured using a device called **force meter**. Force meters come in many forms and designs. The most common ones are the ones that make use of elastic materials like springs and rubber bands. An example of a force meter is Spring force metre. (see Fig. 2.9(a)). This is a device that measures the magnitude of a force. The spring stretches when a force is applied to the hook, and a reading is taken from the scale. Fig 2.9(b) shows a digital force meter.



a) Spring force metre



b) Digital force metre

Fig 2.9: force meters



## 2.4 Representation of forces using vector diagrams

### Activity 2.7

#### To demonstrate representation of force

##### Material

- Marbles

##### Steps

1. Arrange the marbles on top of your desk in a straight line (Fig. 2.10).

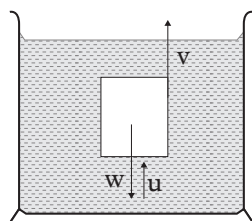

Fig. 2.10: Movement of marbles

2. Give one marble a slight push toward others. As it moves and hits the next one, what happens?
3. Does it stop after the others start moving? Explain why.
4. What do you think would happen if the first marble hit the second at an angle and not just straight ahead?
5. Discuss with your group members your observations and suggest how forces are represented.

We have already learnt that, force is a **vector quantity**, that is, *it has both magnitude (size) and direction*. A vector is normally represented by a line with an arrow head (  $\longrightarrow$  ). The length of the line represents the magnitude and the arrow head shows the direction. We therefore need a way of representing both magnitude and direction on a diagram in order to represent forces.

A diagram showing all the forces acting on a body in a certain situation is called a **free body diagram** or simply a **vector diagram**. A free body diagram shows only the force acting on the object under consideration, not those acting on other objects. Fig. 2.11 shows forces acting on a body falling in a liquid.



$v$ , is the viscous drag of the liquid.

$w$ , is the weight of the object.

$u$ , is the upthrust in the liquid.

Fig. 2.11: A moving object in a liquid

Fig. 2.12 shows a body moving toward right on a rough surface.

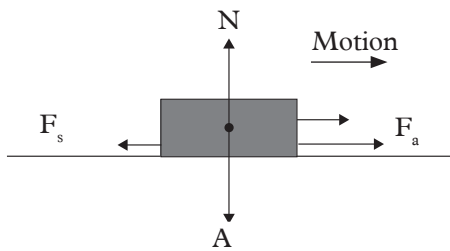

N is the normal reaction.  
 F<sub>a</sub> is the applied force.  
 F<sub>s</sub> is the friction force.  
 A is the action force or (weight).

Fig. 2.12: Normal, applied force and friction force

Fig. 2.13 shows a person pushing a wheelbarrow.

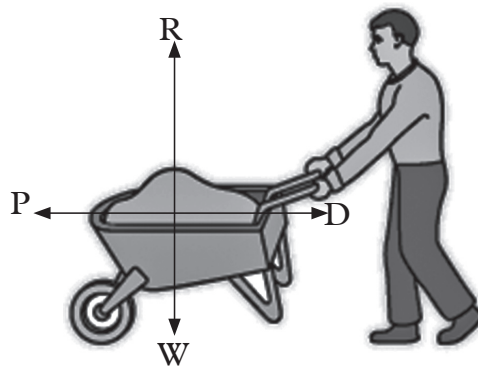

Fig. 2.13: Shows a wheelbarrow being pushed towards left

R is the reaction force of earth on the wheelbarrow. This force acts at right angle (or normally) to the ground. It is also referred to as the **normal reaction force**.

P is the forward force exerted by the worker on wheelbarrow.

W is the pull of earth on wheelbarrow (its weight).

D is the drag force acting on the wheelbarrow.

## 2.5 Combination of forces

### Parallel forces

#### Activity 2.8

#### To demonstrate parallel forces

#### Materials

- A block of wood
- Two identical springs

#### Steps

1. Place a block of wood on a rough surface.

2. Pull the block using a string attached to a spring balance until the block just starts to move Fig. 2.14(a). Record the value of the force applied.
3. Repeat the activity but use two identical springs parallel to each other. (Fig.2.14(b)). Record the force applied in each of the springs.

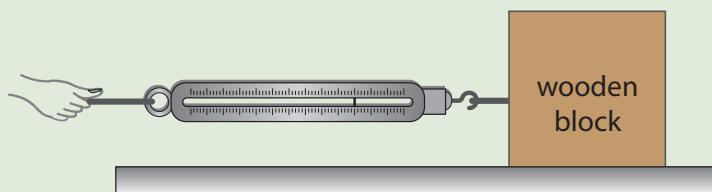

(a) Pulling a block using one spring

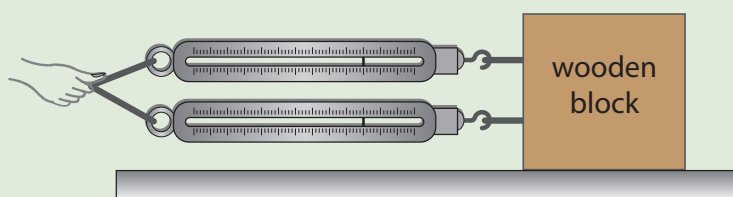

(b) Pulling a block using two springs

Fig. 2.14: Measuring force using spring balance

4. Compare the value of the forces applied in steps 2 and 3. Explain the difference if any.
5. What will happen if the springs were used to pull the wooden block in opposite direction from each other?

When pulling together two springs, the same value is recorded on both springs. This value is half of that recorded by the single spring.

Let the force applied by the single spring A values =  $y$

Force applied by each one of the two spring =  $x$

Therefore,  $x + x = y$

$$2x = y$$

$$x = \frac{y}{2}$$

When several parallel forces act together on the same body in the same direction the combined or resultant force can be added by the ordinary rules of arithmetic. If the Activity 2.9 is repeated with two equal forces pulling the wooden block at the same time but in opposite direction, one force cancels or counters the other one. If the force in one direction is taken as positive, then the force in the other direction is taken as negative.



When a number of parallel forces act on a single body, the resultant force acting on the body can be found by adding all the forces taking considerations of the directions (+ or -).

### Example 2.1

Two oxen are pulling a heavy block along a floor in the same direction. One exerts a horizontal force of 800 N and the other a force of 1000 N. If the frictional force between the crate and the floor is 430 N.

- (a) Draw the force diagram.
- (b) Find the total horizontal force in (a) above.
- (c) Find the direction of the force in (a) above.

### Solution

(a)

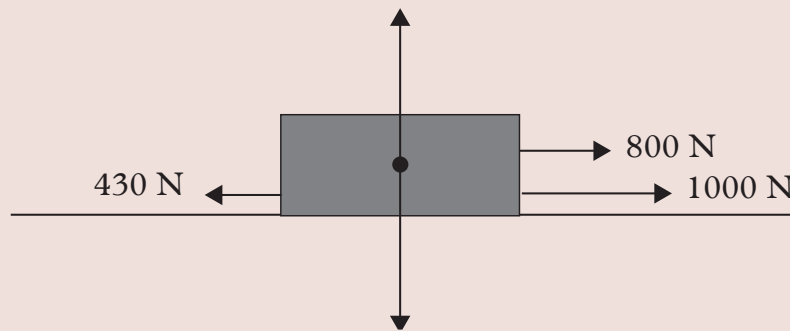

Fig. 2.15: Addition of parallel forces

- (b) We shall choose the forward direction as positive since the frictional force opposes motion i.e. acts backwards in the negative direction.

$$\text{Force exerted by the oxen} = 800 \text{ N} + 1000 \text{ N}$$

$$\text{Force exerted by friction} = -430 \text{ N}$$

$$\begin{aligned} \text{The total sum of force on the crate} &= 800 + 1000 - 430 \text{ N} \\ &= 1370 \text{ N} \end{aligned}$$

$$\text{The resultant force on the crate} = 1370 \text{ N}$$

- (c) Since the force is positive its direction is forward.

## Exercise 2.1

1. Name all the forces acting on the following:
  - (a) A book resting on a table.
  - (b) A book which is being pushed across a flat rough table by a student's finger.
  - (c) A stone resting on a rough sloping board.
  - (d) A box supported on a tall thin pillar.
2. Draw force diagrams for the cases in question 1.
3. Find the resultant of the following sets of forces:
  - (a) A force of 35 N backwards and a force of 35 N forward.
  - (b) A force of 120 N upwards and a weight of 150 N.
  - (c) A force of 29 N upward, a force of 34 N upward, and a force of 50 N downwards.

## Non-parallel forces

### Activity 2.9

#### To demonstrate non-parallel forces

(Work in groups of three)

#### Materials

- A ring
- 3 ropes/strings

#### Steps

1. Tie three ropes at different points on the ring as shown in Fig 2.16.

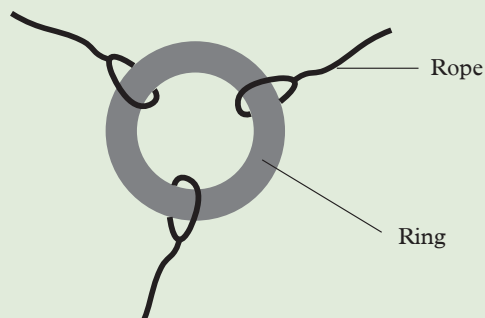

Fig. 2.16: Strings tied to a ring

2. Let three of you pull each rope in different directions.
3. Do all of you pull the ropes with the same force?
4. What happens when you all pull the ropes?

When one rope is pulled by a greater force than the rest, the other two, move towards its direction. However, when the ropes are pulled with the same force, neither of you moved to any particular direction since the forces are balanced.

These three forces in this activity act on the ring in different directions. Such forces are called **non-parallel forces**.

## Addition of non-parallel forces

### Activity 2.10

#### To illustrate addition of non-parallel forces

(Work in groups)

#### Materials

- 3 - identical spring balances
- Plane paper
- A ring
- 3 - heavy wooden blocks

#### Part A

1. Cover the top of a table with a plane paper.
2. Hook the spring balances to wooden blocks.
3. Hook the springs to the ring by means of loose loops of the string as shown in Fig 2.17.

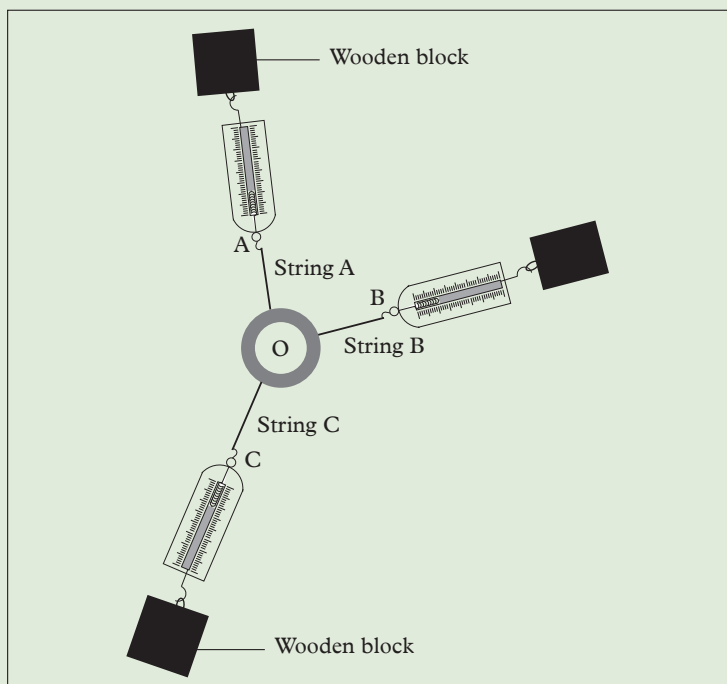

Fig. 2.17: Addition of non-parallel forces

4. Move the wooden blocks outwards until each spring balance is showing appreciable reading. Record the readings of the spring balances.
5. Tap the ring and the strings so as to be in their true position. Is the ring balanced? Give a reason. Mark the centre of the ring as point O.
6. Draw a straight line along each string. Mark points A, B and C along the lines representing the respective strings as shown in Fig. 2.17.

From Activity 2.10 part A, the ring is observed to be in equilibrium i.e. state of balance. Therefore, the total force acting upon it must be zero. This can be shown by adding together the forces exerted by spring balances A, B and C as shown in part B below.

### Part B

#### Steps

1. Remove the set ups.
2. Produce the lines through A, B and C inwards to meet at O.
3. Using a suitable scale, mark off distances OA, OB and OC accurately and proportional to the readings you recorded for the respective springs.
4. Construct a parallelogram OBRA and draw the diagonal OR (see Fig 2.19).
5. Find the length OR and compare it with the length OC. What can you say about forces OC and OR. What is the relationship between Forces OA, OC and OR.

The magnitude force OR and OC are equal in magnitude but opposite in direction (Fig. 2.18).

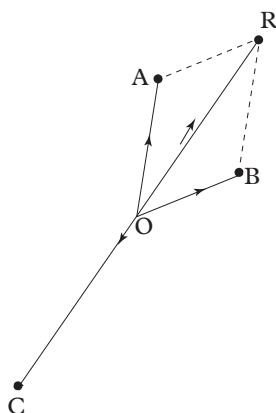

Fig. 2.18: Construction of parallelogram

This force OR represent the resultant force exerted by OA and OB. This method of obtaining the resultant of two forces is called **the parallelogram law method** which says that;

If two forces are represented in magnitude and direction by two sides OA and OB of the parallelogram OARB, then the resultant is represented in magnitude and direction by the diagonal OR.

### Example 2.2

A wooden crate is pulled horizontally by two forces of 250 N and 150 N at an angle of  $70^\circ$  to each other. (Fig. 2.19). Determine the resultant force on the box.

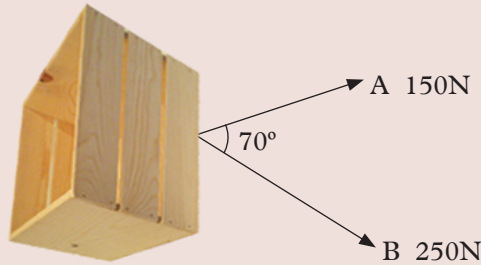

Fig. 2.19: Wooden crate being pulled by two forces

### Solution

Using a scale of 1.0 cm represent 50 N

Draw a line OA to represent 250 N

Draw a line OB to represent 150 N

Let O be the common point and the angle between the two lines be equal to  $70^\circ$

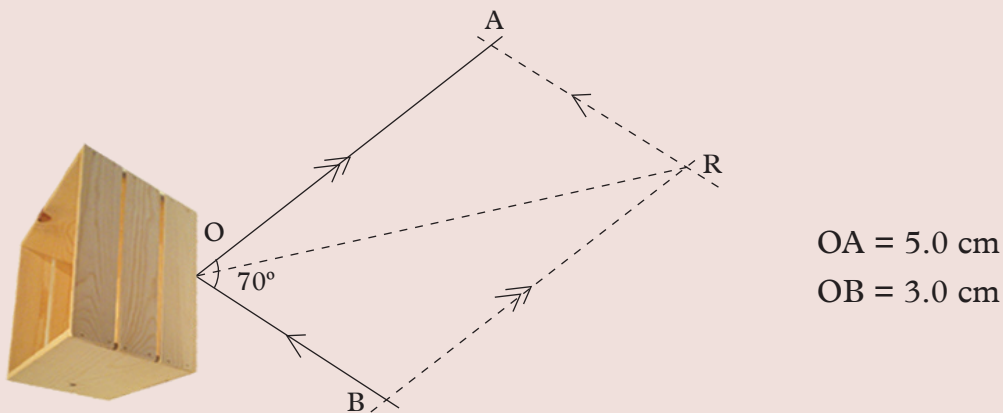

Fig 2.20: Parallelogram of forces acting on a crate

Construct the parallelogram OARB using these lines OA and OB as adjacent sides and measure the diagonal  $OR = 6.9$  cm.

Using the scale of 1.0 cm = 50 N, we find the resultant force is 345 N.





NB: When the angle between two forces is very close to  $0^\circ$  or close to  $180^\circ$ , the parallelogram of forces folds down into a flattened form lying almost along a single straight line. The parallelogram rule of addition of slanting forces then gives the same result as the simple addition rule for parallel forces.

### Equilibrium of three non-parallel forces

Consider a balloon suspended from a rigid support (Fig. 2.21).

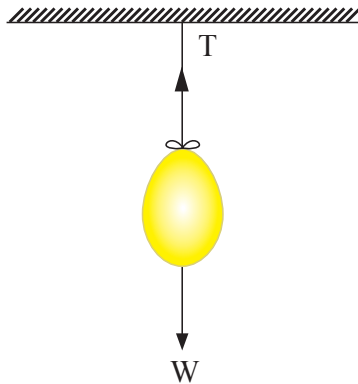

Fig. 2.21: Suspended balloon

Supposing the wind exerts a horizontal force on the balloon. The balloon moves and stops with the string making an angle with the vertical line. The balloon is in equilibrium under the force due to the wind, the force due to the balloons own weight, and the tension in the string.

The resultant of the wind force and the weight in the string is therefore equal and opposite to the tension in the string. Hence, the net resultant force is equal to zero at equilibrium.

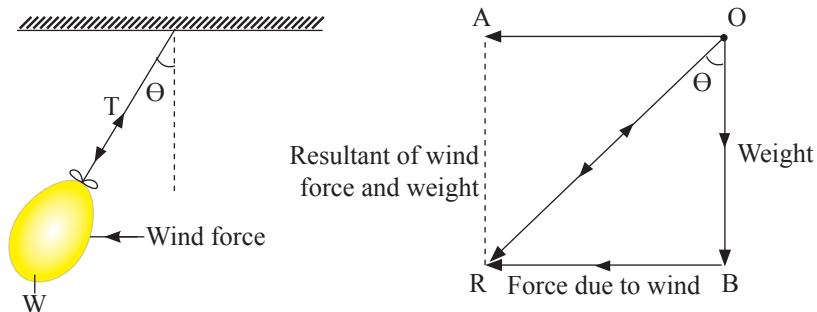

Fig. 2.22: Determining resultant force of suspended balloon

The resultant force is known to act in the same straight line as the tension in the string.

## Exercise 2.2

1. State the parallelogram law.
2. Explain the term equilibrium.
3. A box is moving constantly across a rough horizontal floor, pulled by two horizontal ropes. One of the ropes has a tension of 150 N and makes an angle  $20^\circ$  with the direction of motion of the box. The other rope with a tension force of 90 N makes an angle  $40^\circ$  with the direction of motion of the box.
  - (a) Sketch the arrangement.
  - (b) By scale drawing find the resultant forward force acting on the box.

## 2.6 Types of forces

### 2.6.1 Contact forces

Contact forces are those forces that act at the point of contact between two objects, in contrast to body forces. Examples of contact forces are *tension, normal action reaction force, air resistance, upthrust and frictional force*.

#### (a) Tension force

### Activity 2.11

To demonstrate the existence of tension forces in strings

(Work in pairs)

#### Materials:

- A string
- A pail with water
- Rigid support

#### Steps

1. Hold one end of a string and your friend the other end.
2. Let both of you pull the ends away from each other as shown in Figure 2.23. What makes the string stiff?

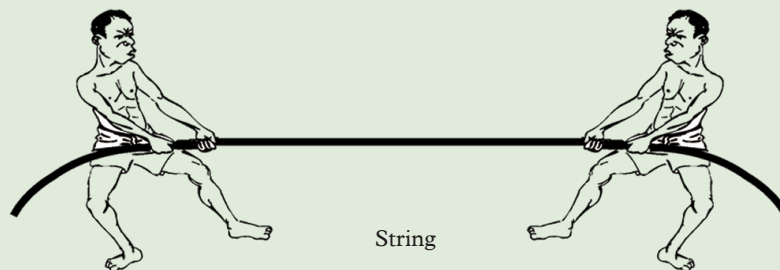

Fig. 2.23: Pulling a string

3. Discuss your observations in step 2 with your class partner.
4. Tie a string to the pail and hang it as shown in Figure 2.24.
5. Discuss with your class partner any forces acting on the string and the pail in fig 2.24.
6. Sketch a diagram to show the direction in which the forces in step 2 and 4 are acting and state where this forces are applied.
7. Compare your findings in step 5 and 6 with those of other pairs in the class.

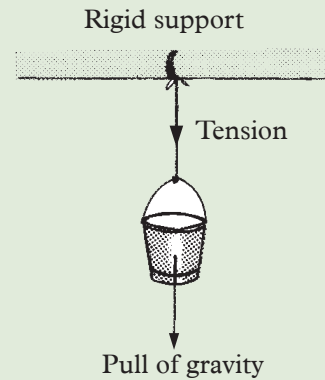

Fig. 2.24: Pail with water

## (b) Action and reaction forces

### Activity 2.12

### To demonstrate action and reaction forces

(Work in groups)

#### Materials:

- A rigid support
- Two identical spring balances

#### Steps

1. Hook one end of a spring balance A to a rigid support e.g a wall. Pull the other end until the spring shows a reading (see Fig 2.25(a)).
2. Discuss with your partner what happens to the rigid support.
3. Repeat the activity by using a similar spring B instead of a rigid support.
4. Pull the two springs until the reading on spring A is the same as before (see fig 2.25(b)). What reading is shown by spring B? What is the relationship between reading A and reading B? Explain.

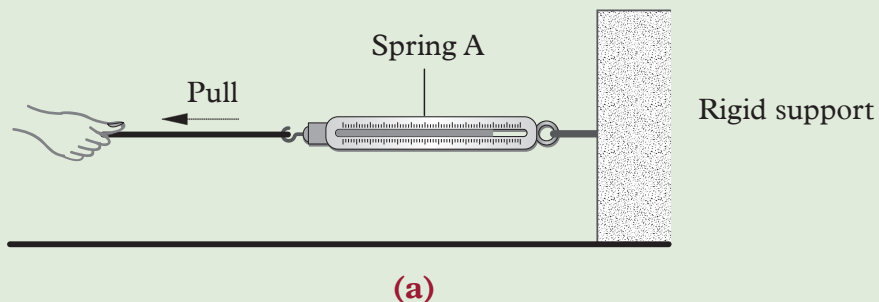

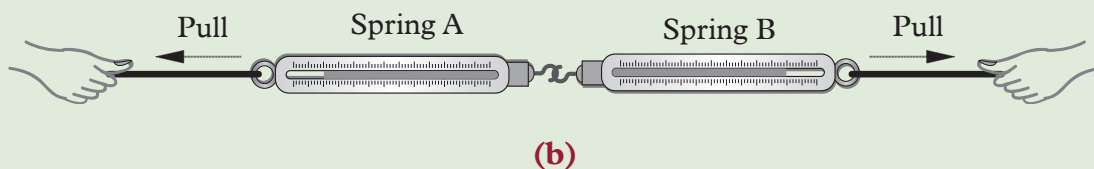

Fig. 2.25: To demonstrate action and reaction forces

When two springs are pulled in opposite direction they will show same reading. This implies that there are two equal forces which are acting in opposite directions in the two springs.

Similarly, when a spring fixed on a rigid support is pulled, the support also pulled it with an equal and opposite force. These two equal forces that act in opposite directions are called **action** and **reaction force**.

Another example that shows action and reaction force is when a book is placed on a table. The weight of the book provides action force while the table supporting the book provides reaction (Fig. 2.26)

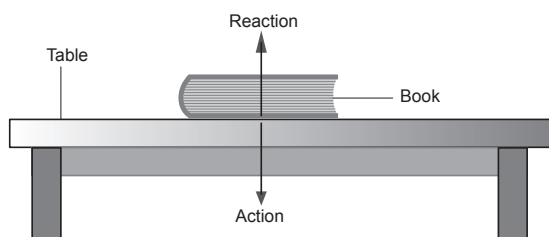

Fig. 2.26: A book on a table

### Activity 2.13

#### To demonstrate action and reaction forces

(Work in groups)

#### Materials

- A bench
- A wooden block

#### Steps

1. Press the bench downwards with your thumb (Fig. 2.27). What do you feel? Suggest the kind of force acting on your thumb.



Fig 2.27: Thumb pressing on a table

2. Place a wooden block on the bench. Suggest the forces that are acting on the wooden block and the direction in which it is acting.
3. Lift one side of the bench top upwards at an angle  $\theta$ . Ensure that the wooden block does not fall down. (see Fig 2.28)

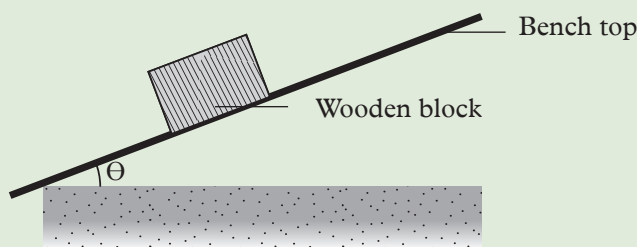

Fig 2.28: Wooden block at an angle

4. Identify the forces that are acting on the block of wood in step 3.

When you press with some force on a wall with your thumb, the force you feel acting on your thumb by the table is called **reaction force** and the one acted by the thumb on the table is called **action force**.

This activity has shown that the reaction and action forces are always perpendicular (normal) to the surface of the body exerting the reaction (Fig 2.29)

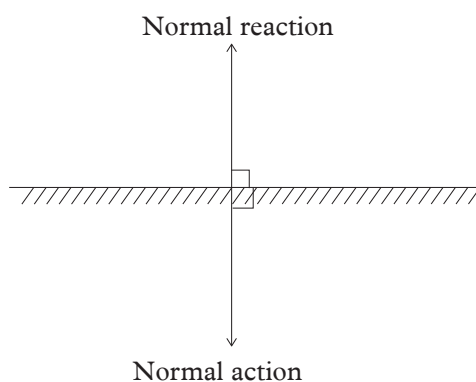

Fig. 2.29: Normal reaction and action perpendicular to the surface

Normal reaction and action also acts on the wooden block resting on the bar (step 2).

The force due to the block is called the **action force**, while that due to the table is called **normal reaction force**. Since the block is at rest the two forces must be equal though acting in opposite directions. (Fig. 2.30).

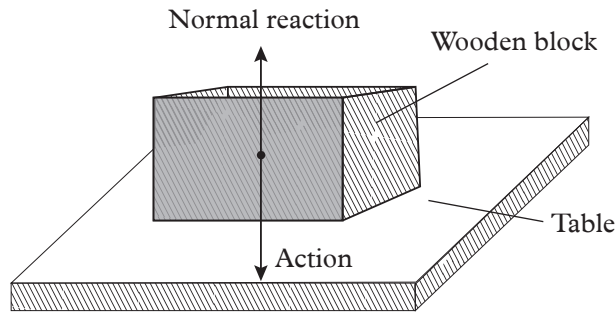

Fig. 2.30: Action and reaction forces

The forces that are acting on a wooden block when the bench top is lifted at an angle  $\theta$  are shown in Fig 2.31.

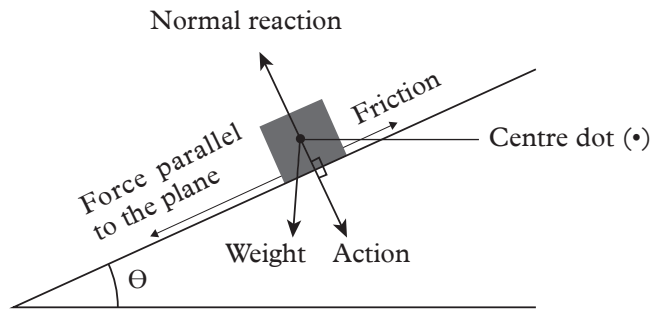

Fig 2.31: Forces acting on a wooden block at an angle



**Note:** The normal action force is the component of weight in an inclined body.

### Exercise 2.3

Give explanation to the following observations:

- (a) A balloon will start moving when the air inside it is released.
- (b) A garden sprinkler starts rotating immediately the water starts to jet out of nozzles.
- (c) When a gun is fired, the holder shakes as the gun tends to move backwards(recoil).

## (c) Upthrust

### Activity 2.14

### To demonstrate upthrust force

(Work in groups)

#### Materials

- Resort stand
- A spring balance
- Metre rule
- Beaker with water
- A solid mass.

#### Steps

1. Suspend a solid in air using a spring balance (Fig 2.32(a)). Note its weight.
2. Push the solid upwards gradually with your hand (Fig 2.32(b)). What happens to the reading of the balance? Explain.
3. Release the solid and submerge it in a fluid such as water as shown in Fig 2.32(c). What is the weight of the solid? Note it down.

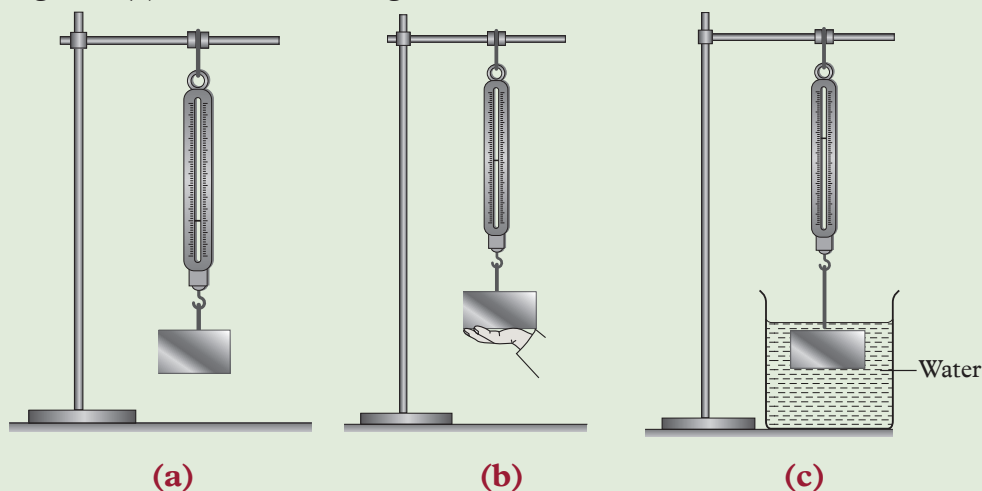

Fig. 2.32: To demonstrate upthrust force

4. Compare the weight of the solid in air and water. Note it down. Suggest the reason for your observation.
5. Use the observation you have made to explain why a ball held under water will jump into the air when released.
6. How will the weight compare if a different liquid e.g honey was used in place of water? Explain.

When a solid hung on a spring balance is pushed upwards, the pointer moved upwards. Similarly when the solid is submerged in water while still hanging on a spring balance, the pointer moves upwards due to upward force in water which acts from below the solid submerged in it. This upward force due to a fluid is called **upthrust**.

The difference between weight in air and weight in water (a liquid) is known as **apparent loss in weight of a body**.

$$\text{Apparent loss in weight} = \text{upthrust} = w_{\text{air}} - w_{\text{liquid}}$$

### Example 2.3

A metal block weighs 20 N when in air and 14 N when submerged in water. Determine the upthrust on the block.

#### Solution

$$\begin{aligned}\text{Upthrust} &= \text{Weight in air} - \text{Weight in fluid} \\ &= 20 \text{ N} - 14 \text{ N} \\ &= 6 \text{ N}\end{aligned}$$

### Example 2.4

A body weighs 3.5 N in air. When the body is completely immersed in water the upthrust on the body is 1.6 N. Find the weight of the body in water.

#### Solution

$$\begin{aligned}\text{Upthrust} &= W_{\text{air}} - W_{\text{water}} \\ W_{\text{water}} &= W_{\text{air}} - \text{upthrust} \\ &= 3.5 - 1.6 \\ &= 1.9 \text{ N}\end{aligned}$$

### Factors affecting the magnitude of upthrust

Magnitude of the upthrust depends on the following factors:

- *Density of the liquid.*

As the density of the liquid increases, the upthrust increases and vice versa i.e a denser liquid exerts greater upthrust on an object than the less dense liquid.

- *The volume of the body immersed in the liquid.*

The greater the height, and hence the volume of the portion of the object submerged into liquid, the greater the upthrust exerted on the body.



## Upthrust and archmedes principle

### Activity 2.15

To investigate the relationship between upthrust and the weight of water displaced

#### Materials

- An iron bar
- Wood block
- An overflow can (eureka can)
- A compression balance

#### Steps

1. Weigh a uniform iron bar in air. Fill an overflow can (eureka can) with water. Allow the excess water to flow out through the spout.
2. Place an empty beaker on a compression balance under the spout and record its weight.
3. Immerse a quarter of the length ( $0.25 l$ ) of the iron bar into water (Fig. 2.33). What happens to the water in the eureka can?

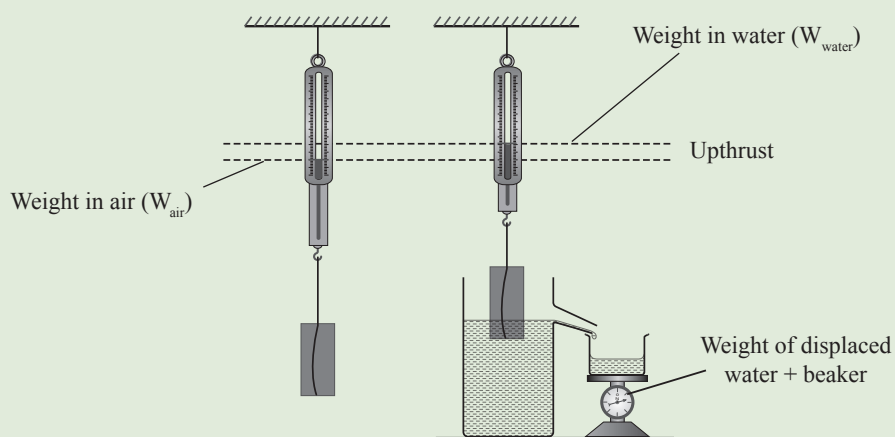

Fig. 2.33: Effect of the weight of liquid displaced on upthrust

4. Record the upthrust and the weight of the liquid displaced as read from the spring balance and compression balance respectively.
5. Repeat the experiment with half length  $0.5 l$ , three quarter length  $0.75 l$  and full length  $l$ , of the iron bar immersed in the water. Tabulate your results as in the Table 2.1.

Table 2.1

Portion immersed	Upthrust = $W_{\text{air}} - W_{\text{water}}$ (N)	Weight of displaced water (N)
0		
0.25 l		
0.5 l		
0.75 l		
1l		

6. Plot a graph of upthrust against weight of the water displaced.
7. Calculate the slope of the graph. What does the slope represent? What is the relationship between the water displaced and upthrust?
8. Now replace the iron bar with a block of wood and lower it into the water. What happens to the spring as you lower the block into the water? What is the reading on the spring balance when the block comes to rest? What is the relationship between the weight of the block and the weight of the displaced fluid?

The iron bar displaces some water which goes into the beaker.

The graph is a straight line graph passing through the origin (Fig. 2.34). This shows that *upthrust is directly proportional to the weight of liquid displaced*.

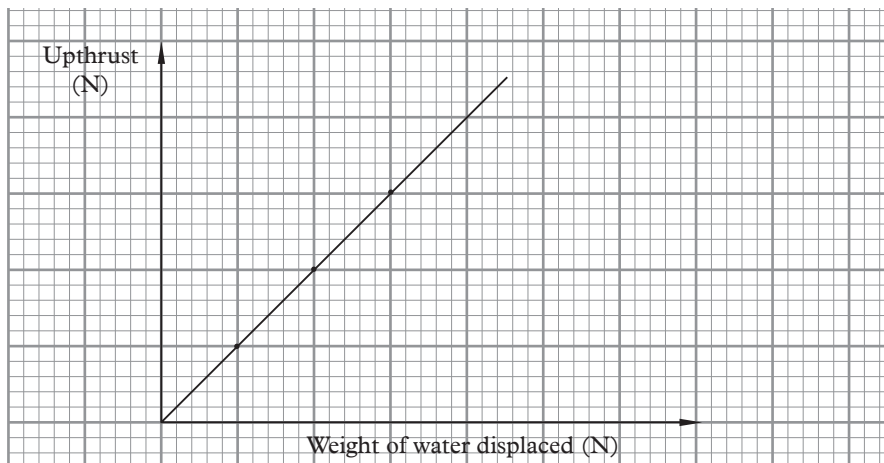

Fig. 2.34: A graph of upthrust against weight of water displaced

The slope of graph is 1.

Therefore upthrust is equal to the weight of water displaced.

Similar experiment with other liquids show similar results i.e.

$$\text{Upthrust} = \text{weight of liquid displaced}$$

Experiments involving gases instead of liquids give results similar to ones obtained using liquids.

Therefore for all fluids

$$\text{upthrust} = \text{weight of fluid displaced.}$$

Activity 2.15 is a verification of what is called *Archimedes' principle*, which states that:

*When a body is wholly or partially immersed in a fluid, it experiences an upthrust which is equal to the weight of the fluid displaced.*

$$\text{Upthrust} = \text{weight of fluid displaced} = \text{Apparent loss in weight}$$

If a block of volume,  $v$ , hung from a spring balance using a thin string is lowered gradually into water of density  $\rho$ , in an overflow can, it displaces some water. The string becomes slack when the block of wood comes to rest, i.e the block is in equilibrium. Since the weight of the block in air minus upthrust is equal to the tension in the string, when the tension in the string is 0, the weight of the block in air is equal to the weight of the fluid displaced. Hence

$$\text{weight of the floating body} = \text{weight of fluid displaced.}$$

This is the law of floatation which is a special case of Archimedes' principle in that the apparent weight of a body is zero in the fluid.

### Note

1. The same effect is observed for a partially immersed cube.
2. The forces on the sides are equal but act in opposite directions hence the is no net force on the sides of the cube is zero.

### Example 2.5

A concrete block of mass  $2.7 \times 10^3$  kg and volume  $0.9 \text{ m}^3$  is totally immersed in sea water of density  $1.03 \times 10^3 \text{ kg/m}^3$ . Find:

- (a) Weight of the block in air.
- (b) Weight of the block in sea water.

### Solution

$$\begin{aligned} \text{(a) Weight in air} &= mg \\ &= 2.7 \times 10^3 \times 10 \\ &= 2.7 \times 10^4 \text{ N} \end{aligned}$$

$$\begin{aligned} \text{(b) Volume of water displaced} &= \text{volume of the block} \\ &= 0.9 \text{ m}^3 \end{aligned}$$

$$\begin{aligned}\text{Weight of water displaced} &= V\rho g = 0.9 \times 1.03 \times 10^3 \times 10 \\ &= 9.27 \times 10^3 \text{ N}\end{aligned}$$

$$\begin{aligned}\text{Upthrust} &= \text{weight of water displaced} \\ &= 9.27 \times 10^3 \text{ N}\end{aligned}$$

$$\begin{aligned}\text{upthrust} &= W_{\text{air}} - W_{\text{liquid}} \\ \therefore W_{\text{liquid}} &= W_{\text{air}} - \text{upthrust} \\ &= (27 \times 10^3) - (9.27 \times 10^3) \\ &= 17.73 \times 10^3 \text{ N} \\ &= 1.77 \times 10^4 \text{ N}\end{aligned}$$

### Exercise 2.4

- Define the term upthrust.
- An object weighs 5 N in air and 4.55 N when submerged in water. Calculate the upthrust acting on the object.
- Explain the importance of upthrust force to:
  - Divers and some animals e.g crocodiles.
  - Ship manufacturing industry.
- What do you understand by the term upthrust in fluids?
  - State the Archimedes principle.
  - With the aid of a well labelled diagram describe an experiment to verify Archimedes principle.
- A piece of metal of mass 800 g and volume  $20 \text{ cm}^3$  is suspended from a spring balance and is completely immersed in a liquid of density  $790 \text{ kg/m}^3$ . Determine the reading of the spring balance.
- A metal block of density  $7.8 \text{ g/cm}^3$  weighs 117 N in air. Find the weight of the block when wholly immersed in water of density  $1.0 \text{ g/cm}^3$ .
- A block of mass 250 g is supported in air from a spring balance. The compression balance reads 0.5 N (Fig. 2.35). The block is then lowered such that it is fully immersed in the liquid of density  $1.03 \times 10^3 \text{ kg/m}^3$ . A volume of  $100 \text{ cm}^3$  of the liquid is collected in the cylinder.
  - Calculate the density of the block.
  - What is the spring balance reading?

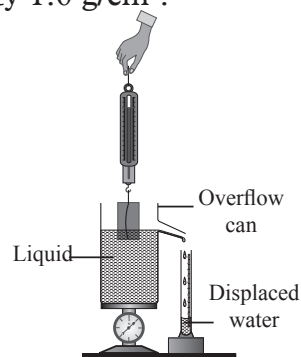

Fig. 2.35: Displacement method

- (c) What is the compression balance reading?
- (d) Calculate the reading of the spring balance when the block is immersed.
8. A metal cube of mass 640 g and density  $2.7 \text{ g/cm}^3$  is suspended half immersed in a liquid of density  $0.8 \text{ g/cm}^3$  using a thread. Find the tension in the thread.
9. A cube of side 5 cm weighs 18.7 N in air. Calculate
- the density of the material making the cube
  - its apparent weight when completely immersed in a liquid of density  $0.80 \text{ g/cm}^3$ .
10. A spring has unstretched length of 185 mm. When a piece of metal of mass 1.5 kg is attached to the spring, the spring extends to a length of 204 mm. When the metal is completely immersed in water of density  $1000 \text{ kg/m}^3$  its length becomes 175 mm. Find
- the force needed to produce an extension of 5 mm,
  - upthrust on the metal,
  - the volume of the metal.
11. A block of length 30 cm, cross-sectional area of  $3 \text{ cm}^2$  and density  $1.3 \text{ g/cm}^3$  is completely immersed in a liquid of density  $1.03 \text{ g/cm}^3$ . Find
- the mass of the block,
  - the weight of the block in the liquid,
  - the apparent weight of the block if three quarters of it is immersed.

## (d) Friction force

### (i) Demonstration of friction force

#### Activity 2.16

#### To investigate existence of friction force between surfaces

(Work in groups)

#### Materials

- Wooden block
- Rough and smooth surface
- A light spring
- Sand paper
- Ball bearings

#### Steps

- Using the materials provided, design an experiment to illustrate the existence of friction force.
- Your experiment should include a well explained procedure, observation and conclusion.

3. The observation should clearly show when friction force is experienced and the effect it has on the block of wood when it is stationary and when in motion. You should also explain the effect of using ball bearings between the surface and the wooden block.

When a spring is used to pull a load that is placed on a surface, it records some reading just before the load starts moving. Similarly when application of an external force is withdrawn from a moving object it eventually comes to rest.

In the first case, there is a force preventing the stationary load from moving. In the second case, there is a force compelling the moving object to stop. These forces are called **frictional forces**. The force of friction exists whenever two bodies which are in contact, move relative to one another. If the two bodies are solids, the force is called **solid frictional force**. It does not matter which body is in motion as long as the body is in contact with a surface.

### (ii) Nature of friction force

#### Activity 2.17

#### To observe the smoothness or roughness of the surface of materials

(Work in groups)

#### Materials

- A plane paper
- Sandpaper

#### Steps

1. Observe the surface of a plane paper. Now feel the surface of the paper with your fingers. Note down what you feel.
2. Observe the surface of the same plane paper under a microscope. What is the difference on the smoothness of the plane paper as observed by a naked eye and when observed through a microscope?
3. Now repeat steps 1 and 2 using a sandpaper in place of a plane paper. What is the difference between the two surfaces? How can the friction between two surfaces be reduced?
4. Discuss your findings with the member of your group.
5. Compare and discuss your findings with other groups.

When observing a surface with naked eye, no matter how smooth a surface may appear to be, there are always ridges and bumps that can only be seen under a microscope (See Fig. 2.36).

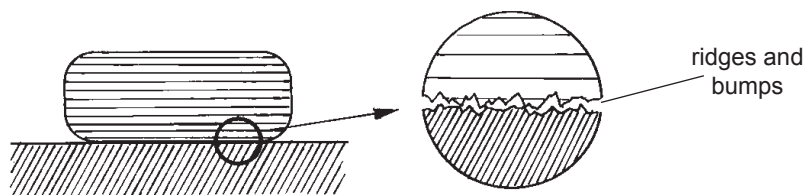

Fig. 2.36: Ridges and bumps as seen under a microscope

The ridges and bumps hold on each other (entangle) and prevent the movement of the two surfaces. When enough force is applied, they release each other (disentangle) and the movement becomes possible. The type of ridges and bumps depends on the **nature of the material in contact**. It is for this reason that the frictional force depends on the nature of the surface and not on the area in contact.

There are four types of frictional force namely; Static friction, sliding friction, rolling friction and fluid friction.

Frictional force that exists in a body that is not moving is called **static friction** while friction when a body is moving is called **dynamic (kinetic) friction**. The maximum static friction beyond which a body moves is called **limiting friction**.

Rolling friction is the force that resists motion when a body e.g. a wheel rolls on a surface. On the other hand fluid friction is the force resisting the relative motion of a body when it slides in a fluid. It is also known as **viscous drag**.

### (iii) Factors affecting friction force

#### Activity 2.18

#### To investigate factors affecting friction force

(Work in groups)

#### Materials

- wood blocks
- Mass
- Dust
- Oil
- Water

#### Steps

1. Design an investigation using the materials provided above to show the factors affecting friction force.
2. In your investigation write down the procedure that you have followed and the effect of using different lubricants during the experiment.
3. Use the conclusion you make from your experiment to answer the following question.
  - (a) Does the weight of the material affect the friction force between the material and the surface?
  - (b) What effect do lubricants have on the friction force?

Frictional force only depends on two aspects:

**i. Nature of surface of materials in contact:**

This is the roughness or the smoothness of the materials in contact. A greater force is required to move two surfaces in contact past each other if their surfaces are rough while a smaller force is needed to move the same materials past each other if their surfaces are smooth.

**ii. Normal reaction:**

This is the force pushing the two surfaces together. Increasing the force pushing the two surfaces together causes the ridges and the bumps (shown in fig 2.36) to come together and increase the surface area in contact with each other. Bearings and rollers reduce friction force by allowing contacting surfaces to roll rather than drag or slide over each other fig.2.37.

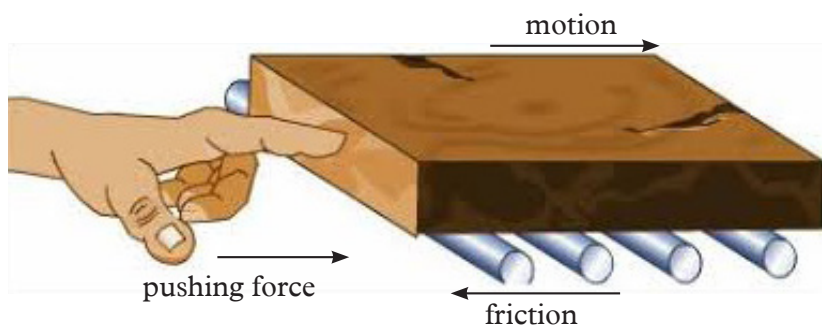

Fig 2.37

**(iv) Effects of friction force**

**Activity 2.19**

**To demonstrate effect of frictional force when writing**

(Work in groups)

**Materials**

- Ball pen
- Smooth glass
- paper
- ceramic tiles

**Steps**

1. Try and write the word “Friction” using a ball point on a smooth glass.
2. Repeat step 1 on a piece of paper.
3. Which of the two surfaces was it easy to write on and why.



Fig. 2.38: A warning sign



From the definition of friction force we can note that it is a force that resists relative motion of solids surfaces, fluids, or elements that collide or slide against each other. Thus we can conclude that friction force is "a necessary evil".

Friction helps in many ways in our daily life like:

**(a) Walking or running**

To move forward you place one foot in front of you and push your other foot backwards on the ground. The friction between your shoe and the ground prevents you from slipping.

**(b) Breaking of the cars**

Friction is used to stop moving cars. Bald tyres (worn out tyres) in smooth (Fig. 2.39(a)). The friction between the road and this tyre is small thus the car may slide on the road during breaking and that is the reason new tyres are preferred. (Fig. 2.39(b)).



(a) Bald tyres has less grip



(b) New tyre has good grip

*Fig. 2.39: Vehicle tyres*

**(c) It prevents slipping or sliding e.g. furniture in our houses.**

**Disadvantages of frictional force**

- (a) Slows down motion of moving objects.
- (b) Produces unnecessary heat. For example car engines becomes hotter.
- (c) Makes it difficult to move things.
- (d) Causes wear and tear of moving parts in machine, motors and engines.
- (e) Increases cost when parts are worn out they need to be replaced with new ones.
- (f) Increases the cost of fuel used to overcome friction force in vehicles.

## Reducing friction force

Frictional force may be reduced by:

1. The use of ball bearing - sliding surfaces must be smooth. If they are rough or rusty, there will be a lot of friction. Ball bearings reduce friction because they roll rather than slid.
2. Replacing sliding friction with rolling friction e.g use of rolling element bearing. Design the moving parts so that they roll on each other rather than slide.
3. Use of lubricants in moving parts e.g. grease or oil (changes or sliding friction into fluid friction).
4. Use of air cushion.

### 2.6.2 Non-contact forces

A non-contact forces is a force applied to an object by another body that is not in direct contact with it. Examples of non-contact forces are *electrostatic*, *magnetic* and *gravitational* forces.

#### (a) Electrostatic force

##### Activity 2.20

##### To demonstrate electrostatic force

##### Materials

- Plastic ruler/pen
- Dry piece of cloth
- Piece of paper

##### Steps

1. Rub a plastic ruler against a dry piece of cloth. Suggest a reason why we do so.
2. Bring the plastic ruler close to small pieces of paper (Fig 2.40). What happens to the pieces of paper? Explain.
3. Discuss with your colleagues in class your observation in step 2.

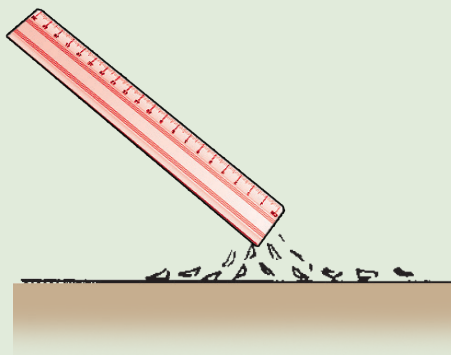

Fig. 2.40: Ruler attracting pieces of paper

When a material such as a glass, plastic, perspex, ebonite, etc is rubbed with some other materials such as silk, rubber, fur, cat skin, etc, both materials get charged by friction. The charges acquired are static in nature. The force of attraction or repulsion between static charges is called **electrostatic force**.

## (b) Magnetic force

### Activity 2.21

To investigate repulsion and attraction effects of a magnetic force

#### Materials

- 2 bar magnet
- Iron rod
- A thread

#### Steps

1. Suspend a bar magnet from a support using a light thread. Allow the bar magnet to swing freely until it comes to rest.
2. Bring a second bar magnet near it from two different sides (Fig 2.41). What do you observe? Explain your observations.

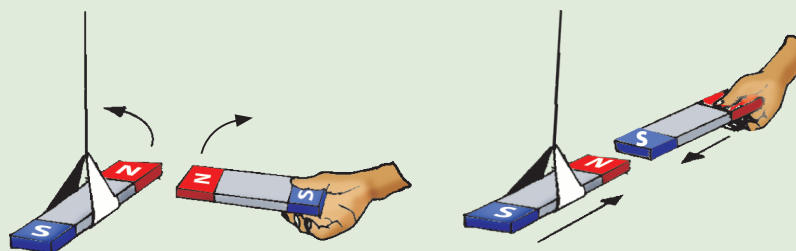

(a) Repulsion

(b) Attraction

Fig 2.41: Behaviour of two poles of bar magnets brought near one another

3. Repeat step 1 and 2 using a bar magnet and iron rod. What do you observe? Explain your observations.

When like poles of the suspended magnet and the other magnet are near each other, the suspended magnet is repelled (Fig 2.41 (a)). However, when unlike pole or iron rod are brought close to the suspended magnet, they are attracted (Fig 2.41 (b)). The repulsion and attraction between magnets is called **magnetic force**. Magnetic forces also exist between magnets and other materials such as iron rod. Such materials that can be attracted with magnetic force are called **magnetic materials**.

### (c) Gravitational force

#### Activity 2.22

#### To demonstrate gravitational force

##### Material

- A ball

##### Steps

1. Hold a ball above the ground and release it. What happens to the ball? Explain.
2. Repeat step 1 but this time throw the ball upwards in the air as far as you can (do it in the field). Observe and describe the motion of the ball.
3. Discuss with your class partner what made the ball to behave the way it did in steps 1 and 2.
4. What do you think will happen to the ball if it was thrown up in a vacuum?

When a ball raised some distance from ground is released, it moves down, hits the ground and eventually comes to rest. When it is thrown upwards, the ball moves up, stops momentarily and comes down.

Sir Isaac Newton made a similar observation as in step 1. He observed an apple falling from a tree and wondered why this was so (see Fig 2.42).

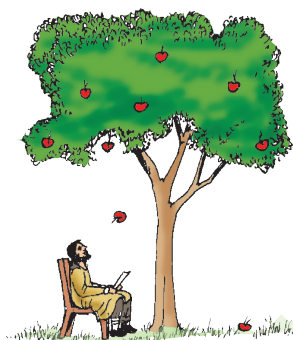
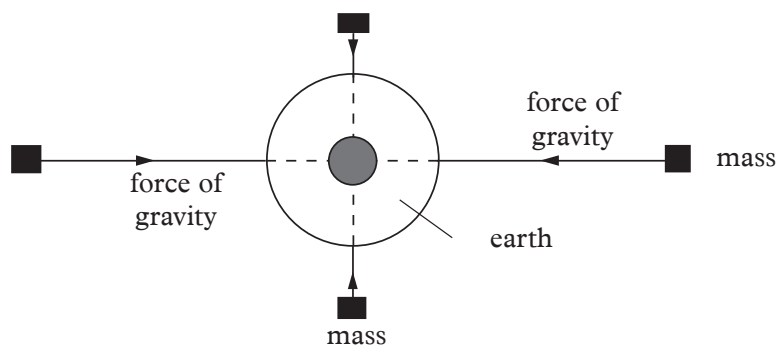

Fig. 2.42: A falling apple

After many experiments, Newton concluded that the apple he saw falling from a tree was attracted downwards by a force in the earth. He called this force of attraction **gravitational force** or **force of gravity**. The force gravity pulls bodies towards the centre of the earth, as observed in Activity 2.42.

Fig 2.43 shows how bodies are attracted by gravitational force towards centre of the earth.



*Fig. 2.43 Force of gravity pulls bodies towards the centre of the earth*

It is important to note that different planets exert their own gravitational attraction to a body. From available clips in the Internet about the people who have gone to the moon, you may have noted that they bounce with ease but on earth a simple action of jumping up, is very difficult. This is because the gravitational force due the moon is less compered to the gravitational force due to the earth. The amount of matter within a person does not change whether on Earth or the moon. However, because Earth is larger (has a greater mass), its gravitational pull is greater on a person. Fig 2.44 shows an astronaut on the moon



*Fig 2.44; astronaut on the moon*

### **Factors affecting gravitational force between two objects**

The strength of the gravitational force between two objects depends on two factors;

#### **i. Mass**

Gravitational force between two objects increases as the masses of the objects increase. Isaac Newton proved that Gravitational force between two objects is directly proportional to the product of the masses of the two objects.

If the mass of one object is doubled the force of gravity between the objects is doubled.

## ii. Distance

The force of gravity between two objects decreases with increase in the distance between them. In other words, the greater the distance between two objects, the lower the strength of gravity is between them. Isaac Newton proved that the force of gravity between them is inversely proportional to the square of the distance between them.

These two factors are summarised in a law that is now referred to as **Newton's Universal Law of gravitation** that states that *"Any two bodies in the universe attract each other with a force that is directly proportional to the product of their masses and inversely proportional to the square of the distance between them."*

### Exercise 2.5

In groups of three, do a research from Internet and reference books on what causes tides in oceans. Discuss your findings with other groups in the class.

## 2.7 Weight and mass

### 2.7.1 Definition of mass and weight

#### Activity 2.23

To determine the weight of an object using a spring balance

#### Materials

- Spring balance

#### Steps

1. Study the spring balance provided. What does it measure?
2. Identify the units labelled on the spring balance. Which units do you think are used to measure weight?
3. Tie a small stone with a string and suspend it on a spring balance. What is the reading on the spring balance?
4. Discuss and compare your findings with other groups in your class.

**Weight is the measure of gravitational pull on an object.** It always act from the centre of a body downwards in the direction of gravitational acceleration. The SI unit of weight is **newton (N)**.

Weight is measured using a spring balance (See Fig. 2.45)



Fig 2.45: A spring balance

**Mass is the quantity of matter in a substance.** The mass of an object does not differ from place to place. For instance the mass of an object on earth will be the same even on the moon. Mass is measured using a beam balance. There are several types of beam balances; fig 2.46 shows a double bar beam balance.

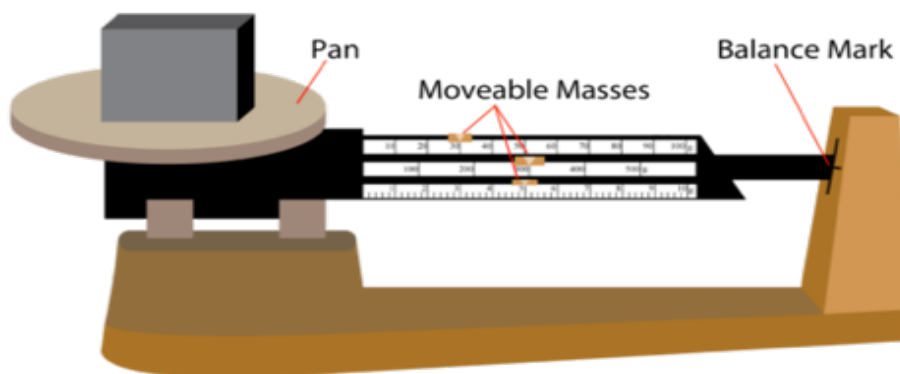

Fig 2.46 double bar beam balance

The **SI unit of mass is kilogram (kg)**. The mass of an object can also be calculated if the force and acceleration of an object are known.



#### My health

Eat a balanced diet and do regular exercise to avoid diseases brought by excessive weight.

## 2.7.2 Relationship between mass and weight

### Activity 2.24

To investigate the relationship between weight (N) and mass (kg)

#### Material

- spring balance

#### Steps

1. Look at the graduations of the spring balance provided to you. Deduce the relationship between the two units (i.e Newton and grams).
2. In your group, find out 1 kg is equivalent to how many newton (N).
3. Write down an expression relating weight and mass.
4. List and discuss five differences between mass and weight.
5. Compare and discuss your findings with other pairs in your class.

In your discussion, you should have come up with the following relationship

$$\text{Weight} = \text{mass} \times \text{gravitational field strength}$$
$$w = mg$$

Hence,

$$\frac{\text{Weight (w)}}{\text{Mass (m)}} = \text{gravitational field strength (g) abbreviated as } \frac{w}{m} = g$$

$$w = mg \text{ or } m = \frac{w}{g}$$

Experimentally it has been shown that the earth pulls a mass of 1 kg with a force of 9.8 N/kg. However a convenient rounded up value of 10 N/kg is commonly used.

$$\text{Gravitational field strength (g)} = \frac{\text{Force (N)}}{\text{Mass (kg)}} = \frac{10 \text{ N}}{1 \text{ kg}}$$
$$g = 10 \text{ N/kg}$$

## 2.7.3 Differences between mass and weight

Table 2.2 shows the main differences between mass and weight.

Mass	Weight
Quantity of matter in a body.	Pull of gravity on a body.
SI unit is kilogram (kg).	SI unit is newton (N).
Constant everywhere.	Changes from place to place.
Scalar quantity.	Vector quantity.
Measured using a beam balance.	Measured using a spring balance.

Table 2.2: Differences between mass and weight



### Example 2.6

A van of mass 2500 kg is authorised to carry 14 passengers. If the average mass per passenger is 50 kg, calculate the:

- (a) weight of the van.
- (b) weight of all passengers.
- (c) total weight of the van and the passengers.

(Take  $g = 10\text{Nkg}^{-1}$ )

#### Solution

(a)  $w = mg$

$$\begin{aligned}w &= 2\,500\text{ kg} \times 10\text{ N/kg} \\ &= 25\,000\text{ N}\end{aligned}$$

(b)  $w = mg = (50 \times 14)\text{ Kg} \times 10\text{ N/Kg}$   
 $= 7\,000\text{ N}$

(c)  $w = (25\,000 + 7\,000)\text{ N}$   
 $= 32\,000\text{ N}$

### Example 2.7

The pull of gravity on Jupiter is about two and a half times of that on earth. What would be the weight of a body of a mass 50 kg on Jupiter? (Take  $g$  on Earth =  $10\text{Nkg}^{-1}$ )

#### Solution

$$\begin{aligned}\text{Gravity on Jupiter} &= 2.5 \times 10 = 25\text{ Nkg}^{-1} \\ \text{Weight} &= \text{mass} \times \text{gravitational field strength.} \\ w &= 50\text{ kg} \times 25\text{ Nkg}^{-1} \\ &= 1\,250\text{ N}\end{aligned}$$

### Example 2.8

A metal weight is 40 N. Calculate its mass (take  $g=10\text{ N/kg}$ ).

#### Solution

$$\begin{aligned}W &= mg \\ \text{This implies that, } m &= \frac{w}{g} = \frac{40}{10} = 4\text{ kg}\end{aligned}$$

## Exercise 2.6

1. Define a vector quantity. Give two examples.
2. Distinguish between mass and weight.
3. Calculate the weight of the following. (Take  $g = 10 \text{ N/kg}$ ).
  - (a) 300 g mass of water.
  - (b) 700 kg mass of sand.
  - (c) 0.05 mg mass of wool.
4. A metal bob of mass 20 g is suspended using a light thread. Calculate the tension developed in the thread. Take  $g = 10 \text{ N/kg}$
5. Near the surface of the Moon, the acceleration due to gravity is  $1.6 \text{ m/s}^2$ .
  - (a) What is the gravitational field strength?
  - (b) Determine the weight of an object on the earth's surface whose mass is 15 kg on the moon's surface.
6. Complete the table in Table 2.3.

Mass (g)	220		4560		36600	
Weight (N)		0.14		1.62		567

Table 2.3: Mass and weight

### Topic summary

- A force is a push or a pull. The SI unit of force is the newton (N).
- Frictional force is that force that opposes relative motion between two surfaces in contact with one another.
- Weight is the gravitational pull in an object.
- A force can cause:
  - Change in the state of motion of a body.
  - Change of the shape of a body.
  - Turning effect on a body.
  - Wear and tear on a body.
- Types of forces include friction, tension, pull of gravity(weight), normal reaction force, air resistant, upthrust, action and reaction force, gravitational, magnetic and electric force.

- Contact force include tension, pull of gravity(weight), action and reaction force, air resistance etc.
- Non-contact force includes gravitational, magnetic and electrostatic forces.
- Force is a vector quantity. It has both magnitude and direction. It is normally represented by a line with an arrow ( $\longrightarrow$ ).
- Weight is measured using a spring balance.
- Mass is measured using a beam balance.

## Topic Test 2

1. Define force and state its SI unit.
2. State three types of contact and non-contact forces.
3. Name the instrument which is used to measure weight.
4. A first aid kit box used at a fire accident scene has a weight of 2 500 N. What is its mass? (Take  $g = 10 \text{ N/kg}$ )
5. The mass, weight and density of chalk is not changed by grinding it into powder, but air friction is greater when the powder falls towards the ground. Explain.
6. Calculate the weight of the following. (Take  $g = 10\text{N/kg}$ .)
  - (a) 500 g mass of milk
  - (b) 900 kg mass of alluminium
  - (c) 0.6 mg mass of cotton
7. A metal bob of mass 20 g is suspended using a light thread. Calculate the tension developed in the thread. (Take  $g = 10\text{N/kg}$ .)
8. What effect of a force is shown in Fig. 2.47?

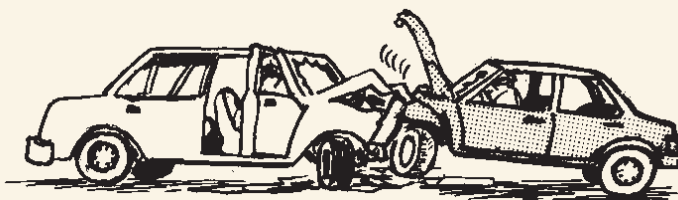

Fig. 2.47: Effect of force on a body

9. What is frictional force?

10. Find the resultant of the following forces:
- 150 N due East and 200 N due West.
  - 450 N due North and 250 N due South.
11. State four differences between mass and weight.
12. Moon's gravitational pull is  $\frac{1}{6}$  of the earth's gravitational pull. Calculate the weight of a body whose mass is 40 kg on:
- the moon's surface.
  - the earth's surface.
13. Three strings are attached to a small metal ring. Two of the strings make an angle of  $70^\circ$  and each is pulled with a force of 7 N, find the force that must be applied to the third string to keep the string stationary.
14. A body is acted upon by two forces each of magnitude 50 N. Find the magnitude of the resultant force on the body when the angle between the two forces is:
- $0^\circ$
  - $45^\circ$
  - $90^\circ$
  - $135^\circ$
  - $180^\circ$
15. A specimen of an alloy is obtained by mixing silver and gold. The alloy weighs 35.2 N in air and 33.13 N in water. Determine the upthrust due to water.
16. The upthrust on a body that is immersed in water is 255 N. If the body weighs 945 N in air, calculate the weight of the object while in water.
17. A body of mass 26 kg weighs 94.6 N in a liquid. Find the upthrust on the body while in the liquid.
18. A building block of mass  $9.17 \times 10^4$  kg and volume  $1.1 \text{ m}^3$  is totally immersed in a salty water lake. The density of the salty water is  $1.03 \times 10^3 \text{ kg/m}^3$ . Find the:
- Weight of the block in air
  - Weight of the block in sea water
19. Fig. 2.48 shows a uniform metre rule balanced by rectangular glass block that is totally immersed in oil of relative density 0.89. The glass block has a volume of  $2.1 \times 10^{-2} \text{ m}^3$ .

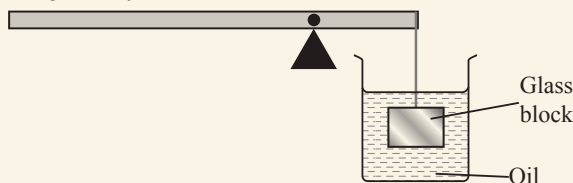

Fig. 2.48

Find the position of the pivot if the mass of the rule is 6.76 kg and density of glass is  $2\,500\text{ kg/m}^3$

**20.** Fig. 2.49 shows a hollow cylindrical tube of mass 26 g closed on one end. If the tube has a cross-sectional area of  $2.5\text{ cm}^2$ ,

**(a)** find the mass to be added into the tube to make it float with its axis vertical and with 15 cm of its length submerged in water.

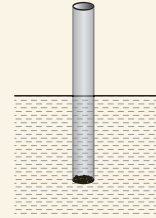

Fig. 2.49

**(b)** what length would be immersed, if the tube is transferred into a liquid of relative density 1.2?

**21.** A metal sphere floats in water with  $\frac{7}{8}$  of its volume submerged. The sphere is transferred in a liquid where it floats with  $\frac{3}{4}$  of its volume submerged

**(a)** Explain why the sphere should be hollow

**(b)** Calculate the relative density of the liquid

**Topic outline** >>>

- Force acting on a surface.
- Definition of pressure and its S.I units.
- Pressure in solid  $P = \frac{F}{A}$  (force acting normally or perpendicular to surface).
- Pressure in fluids: liquids and gases (pressure  $P = \rho gh$ ).
- Pressure in gases.
- Relative density and relationship between density and pressure.
- Hydrostatic pressure  $P = \rho gh$ .
- Atmospheric pressure and height/altitude above sea level.

**3.1 Force acting on a surface****Activity 3.1****To demonstrate force acting on a piece of wood**

(Work in groups)

**Materials**

- A rectangular piece of wood
- Metre rule
- Weighing balance

**Steps**

1. Let each one of you record down their weight.
2. Measure the length and width of the rectangular piece of wood. Record its measurement down.
3. Place the piece of wood on the floor and step on it with both legs. What is the relationship between your weight and the pressure exerted on the piece of wood?
4. Do you think pressure exerted by the wood on the ground when you step on it and on either of the two sides of the block is the same?
5. Calculate the force (weight) per unit area acting on the surface covered by the piece of wood.

In Topic 2, we learnt about force. We showed the effect of force on the surface of a body. In this topic, we are going to learn a familiar terminology called *pressure*

### 3.2 Definition of unit of pressure

We use the word *pressure* almost daily without paying much attention to its exact meaning. In hospitals the nurses and doctors often talk about *blood pressure*. In petrol stations, we add *air pressure* in car tyres. In the kitchen we use *pressure cookers*. Psychologists and counsellors talk about *peer pressure*. A worker would talk about *pressure at work*, etc.

The following activity will help us understand the meaning of pressure.

#### Activity 3.2

To show that pressure depends on the area of contact and the force applied

(Work in groups)

#### Materials

- A piece of bar soap
- A nail
- A stone

#### Steps

1. Take a piece of bar soap. Place a nail on it with the blunt end resting on the soap as shown in Fig. 3.1(a).
2. Place a stone on the sharp end of the nail as shown in Fig. 3.1(a). How deep does the nail go into the soap?
3. Repeat step 2 with the sharp end of the nail on the soap (see Fig. 3.1(b)). How deep does the nail go into the soap?

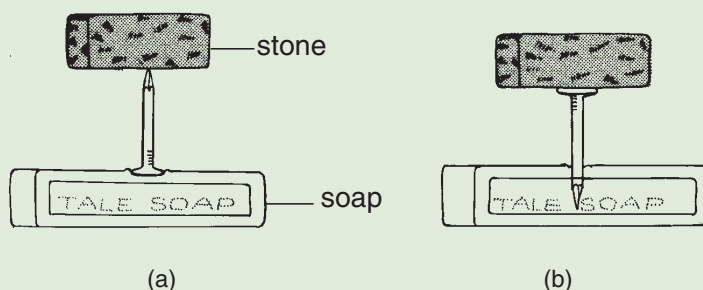

Fig. 3.1: To demonstrate pressure on a solid

4. Now, repeat step 2 and 3 by pushing the stone. Compare the penetration distance in step 2 and 3. How do the two penetration distances relate? Discuss your observations with your group members.
5. Discuss in your groups what pressure is and its SI unit.
6. Suggest two factors that affect pressure in solids.

The nail penetrates a short distance inside the soap when resting on the blunt end while the penetration is more on sharp end.

In both cases, a force acting on surface area produces penetration effect. This penetration effect is large when a force acts on a small area than when the same force acts on a large area. The penetrating effect of a force on a surface area is called **pressure**.

In physics, we define pressure in terms of force and area. Pressure is therefore defined as the *force acting normally (perpendicularly) on a unit area*.

$$\text{Pressure (P)} = \frac{\text{Force (F)}}{\text{Area (A)}}$$

$$P = \frac{F}{A}$$

### Units of pressure

Since the SI unit of force is newton (N) and SI unit of area is square metre (m<sup>2</sup>), the unit of pressure is newton per square metre (N/m<sup>2</sup>). The SI unit of pressure is the *Pascal (Pa)*. 1 pascal is defined as *one newton per square metre* i.e.

$$1 \text{ Pa} = 1 \text{ N/m}^2$$

### 3.3 Pressure in solids

#### Activity 3.3

To show that pressure exerted by a solid depends on the area in contact

(Work in groups)

#### Materials

- A block of stone
- Wet clay

#### Steps

1. Take a regularly shaped stone and place it on a wet clay or any other soil on three different faces as shown in Fig. 3.2. How deep does the stone penetrate in each case? On which side does the stone penetrate the deepest? What makes it to sink that deep?

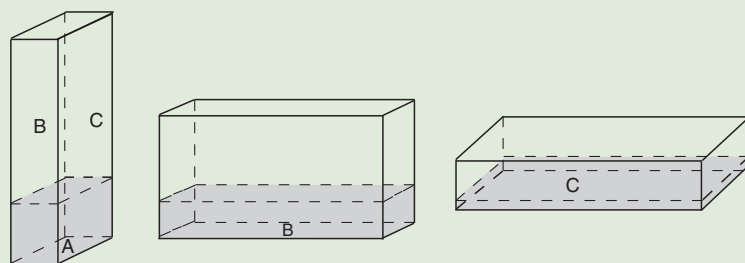

Fig. 3.2: Stone on wet clay

2. Discuss your observations in step 1 with your group members.



When the stone rests on side A, it sinks more than when it rests on side B or C. It sinks least when it rests on side C.

The weight (force) of the stone is the same in all the cases. When the stone is resting on side A, its weight is distributed over a smaller area than when resting on sides B and C. The pressure exerted by the stone is therefore maximum when resting on side A.

If the force applied is more, the pressing ability is more and vice versa.

$$\text{Greatest pressure} = \frac{\text{Force}}{\text{minimum area}} \text{ and}$$

$$\text{Least pressure} = \frac{\text{Force}}{\text{maximum area}}$$

Therefore,

- a solid with a small area of contact, exerts more pressure while that with a large area of contact exerts less pressure on any surface when pressed.
- as seen from the activity 3.2, force and area affect the pressure acting on solids.

### Examples of forces acting on different areas

Fig. 3.3 shows examples of forces acting on different areas. In pairs discuss the resultant pressure in each example given.



High heeled shoe



Heavy lorry with many tyres

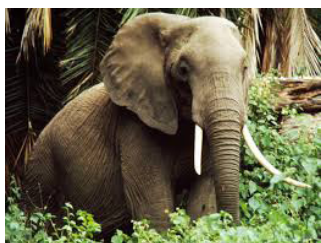

Wide pads of an elephant



Knife cutting bread



hypodermic syringe



Webbed birds

Fig. 3.3: Some common examples of forces acting on different areas



When walking on sandy or muddy ground you should not put on shoes with sharp pointed soles to avoid sinking.

### Example 3.1

Express a pressure of  $35.6 \text{ N/m}^2$  in pascals.

#### Solution

$$1 \text{ N/m}^2 = 1 \text{ Pa}$$

$$35.6 \text{ N/m}^2 = 35.6 \text{ Pa}$$

### Example 3.2

Metallic block of mass  $20 \text{ kg}$  exerts a pressure of  $50 \text{ N/m}^2$  on a flat surface. Determine the area of contact between the block and the surface (Take  $g = 10 \text{ Nkg}^{-1}$ ).

#### Solution

Force = weight of the block

$$= 20 \text{ kg} \times 10 \text{ Nkg}^{-1}$$

$$= 200 \text{ N}$$

$$\text{Since } P = \frac{F}{A}$$

$$A = \frac{F}{P}$$

$$= \frac{200 \text{ N}}{50 \text{ N/m}^2}$$

$$A = 4 \text{ m}^2$$

### Example 3.3

Rose, a senior two student is  $54 \text{ kg}$  and stands upright on a floor. If the area of contact of her shoes and floor is  $420 \text{ cm}^2$ , determine the average pressure exerted by Rose on the floor (Take  $g = 10 \text{ Nkg}^{-1}$ ).

### Solution

$$\text{Pressure} = \frac{\text{Force}}{\text{Area}}$$

$$\begin{aligned}\text{Force} &= \text{Rose's weight} = 54 \text{ kg} \times 10 \text{ N/kg} \\ &= 540 \text{ N}\end{aligned}$$

$$\text{Area} = 420 \text{ cm}^2 \text{ (change into m}^2\text{)}$$

$$1 \text{ m}^2 = 10\,000 \text{ cm}^2$$

$$? = 420 \text{ cm}^2$$

$$\frac{42}{1000} = \text{m}^2 \text{ or } 4.2 \times 10^{-2} \text{ m}^2$$

$$\begin{aligned}\text{Thus, pressure} &= \frac{540}{4.2 \times 10^{-2}} \\ &= 1.2857 \times 10^4 \text{ Nm}^{-2}\end{aligned}$$

### Example 3.4

A rectangular solid glass of density  $2.5 \text{ g/cm}^3$  has dimensions  $10 \text{ cm} \times 40 \text{ cm} \times 30 \text{ cm}$ . The block rests on a horizontal flat surface. Calculate the: (a) minimum pressure, (b) maximum pressure it can exert.

### Solution

(a) For minimum pressure, the area must be maximum.

$$\text{Maximum area} = (40 \times 30) \text{ cm}^2 = 1\,200 \text{ cm}^2 = 0.12 \text{ m}^2$$

$$\text{Density of block} = 2.5 \text{ g/cm}^3$$

$$\begin{aligned}\text{Volume of block} &= 10 \text{ cm} \times 40 \text{ cm} \times 30 \text{ cm} \\ &= 1\,200 \text{ cm}^3\end{aligned}$$

$$\text{Density} = \frac{\text{Mass}}{\text{Volume}}$$

$$\begin{aligned}\therefore \text{Mass} &= \text{density} \times \text{volume} \\ &= (2.5 \times 1\,200) \text{ g} = 3\,000 \text{ g} \\ &= 3 \text{ kg}\end{aligned}$$

$$\begin{aligned}\text{Weight} &= \text{mass} \times \text{pull of gravity} \\ &= 3 \text{ kg} \times 10 \text{ N/kg} \\ &= 30 \text{ N}\end{aligned}$$

$$\text{Minimum pressure} = \frac{\text{Force}}{\text{Area minimum}}$$

$$= \frac{30 \text{ N}}{0.12 \text{ m}^2} = 250 \text{ Pa}$$

(b) For maximum pressure, the area considered must be minimum

$$\text{Minimum area} = (10 \times 30) \text{ cm}^2 = 300 \text{ cm}^2$$

$$= 0.03 \text{ m}^2$$

$$\begin{aligned} \text{Maximum pressure} &= \frac{\text{Force}}{\text{Area minimum}} \\ &= \frac{30 \text{ N}}{0.03 \text{ m}^2} \\ &= 1\,000 \text{ Pa} \end{aligned}$$

### Exercise 3.1

- Define pressure and state its SI unit.
- Explain the following statements in terms of pressure:
  - Large flat feet enable elephants to move freely.
  - It is painful if one tries to lift a heavy load by a thin string.
- Sinking of tyres of a car into soft, damp sand patch may be prevented by letting off some air in each tyre. Explain.
- Three similar blocks A, B and C are placed on a horizontal surface as shown in Fig. 3.4. Which block exerts the minimum pressure on the surface? Explain your answer.

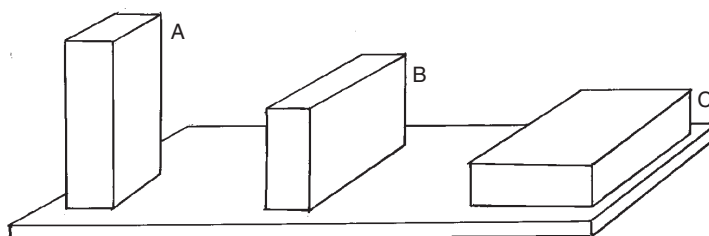

Fig. 3.4

- A pick-up carrying stones weighs 20 000 N. The weight is evenly spread across the four tyres. The area of contact of each tyre with the ground is  $0.025 \text{ m}^2$ . Calculate the pressure exerted by each tyre on the ground.
- A thumb is used to push a thumb pin into a piece of wood. Explain, in terms of pressure, why the pressure on wood is greater than the pressure on the thumb.
  - Find the pressure exerted on a thumb if the force the thumb exerts on a pin of area  $5 \text{ mm}^2$  is 45 N.

7. An elephant of mass 2 000 kg has feet of average area of  $150 \text{ cm}^2$ . A vulture of mass 20 kg walks beside the elephant on a muddy area. The average area of the feet of the vulture is  $1.5 \text{ cm}^2$ . Which one is likely to sink? Explain your answer.
8. A container has a mass of 70 kg. Calculate the pressure it exerts on the ground when the area in contact with the ground is  $0.14 \text{ m}^2$ .

### 3.4 Pressure in liquids

Liquids, unlike solids, do not have definite shapes. They take the shape of the container (See Fig. 3.5).

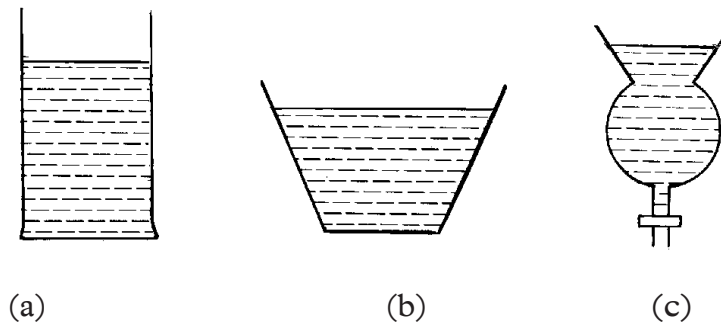

Fig 3.5: Liquids take the shape of a container.

#### Activity 3.4

#### To demonstrate liquid pressure

Work in groups

#### Materials

- A plastic bottle
- Water
- A nail

#### Steps

1. Pierce a hole at the bottom of the container.
2. Using one of your fingers block the hole and pour some water in the container. What does your finger feel?
3. Remove the finger from the hole and explain what happens to the water inside the container.

Like solids, liquids exert pressure. A solid will exert pressure only on the area in contact with the surface but a liquid exerts pressure on all the walls of the container. When the water was poured into the container the finger felt being pushed.

This shows that there is a force in the water that pushes the finger. It is this force that, on removing the finger, forces the water out of the container through the hole as shown in Fig. 3.6.



Fig. 3.6: Water is forced out of the container

### 3.4.1 Liquid pressure act in all directions

#### Activity 3.5

To investigate in which direction liquid pressure acts.

(Work on groups)

#### Materials

- A small polythene bag
- 30 cm thread
- A pin

#### Steps

1. Design an experiment using a small polythene bag or a plastic bottle to investigate in which direction pressure in liquids act.
2. Explain the observation you have made in your investigation.

When water is poured into the polythene bag, it comes out through all the holes. This shows that pressure in liquid acts in all directions. (See Fig. 3.7)

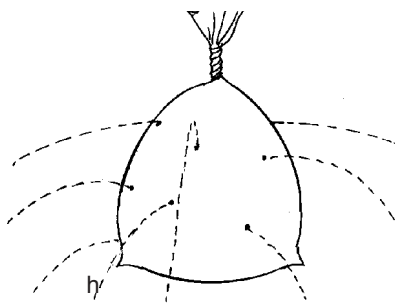

Fig. 3.7: Water comes out through all the holes

### 3.4.2: Pressure at equal depth, acts equally in all directions

#### Activity 3.6

To demonstrate that pressure at equal depths acts equally in all directions

(Work in groups)

#### Materials

- A can
- A nail
- Water

#### Steps

1. Take a can and make similar holes all round the can at the same height (Fig.3.8). Why do you think the holes should be made at similar heights?
2. Fill the can with water and observe what happens.
3. Discuss with other members in your group the observation made in step 2.
4. What do you think would happen to the flow of water if the top of the can was suddenly closed? Explain your answer.

Water travels equal horizontal distances from the can (See Fig 3.8).

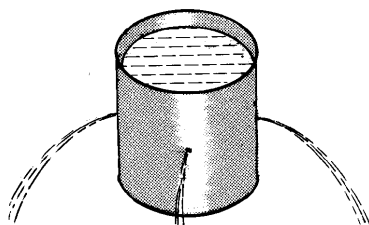

Fig. 3.8: Pressure acts equally at the same level

The pressure exerted by water at this depth is the same in all directions.

### 3.4.3 Factors affecting pressure in liquids

#### Activity 3.7

To demonstrate that pressure in liquids depends on depth

(Work in groups)

#### Part 1

#### Materials

- A cylindrical tin
- A nail
- Water
- Brine
- paraffin

## Steps

1. Make three similar holes on the sides of a long container. One almost at the bottom, another at the middle and the third almost at the top (Fig. 3.9).
2. Pour water in the container and keep the water at the same level by pouring more water into the container. What do you observe? Discuss.
3. Compare the horizontal distances travelled by water from the three holes.
4. Use the conclusion you have made to explain why walls of dams are made thicker towards the bottom?
5. Discuss your findings in step 3 with other members of your group.

Water from hole A travels furthest while water from hole C covers the least distance. (See Fig. 3.9).

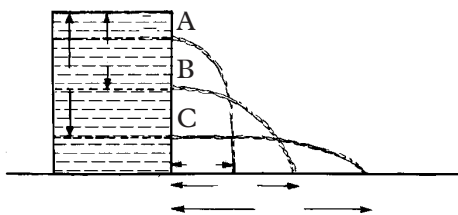

Fig. 3.9: Pressure depends on depth

We therefore conclude that, **pressure in liquids depends on the height/depth of the column of the liquid.**

## Activity 3.8

**To deduce factors affecting pressure in liquids.**

1. Repeat steps 1 and 2 of Activity 3.7 with three liquids of different known densities.
2. Compare the horizontal distance covered by the three liquids. What can you say about their horizontal distances? Discuss.
3. Deduce the factor that affect pressure in liquid from this activity.

The liquid of highest density covers the longest horizontal distance. Therefore, **pressure in liquids depends on the density ( $\rho$ ) of the liquid.**

## 3.4.3 Hydrostatic pressure

### 3.4.3.1 Formula for pressure in liquids

Consider a liquid column ( $h$ ) on an area ( $A$ ) as shown in Fig. 3.10.



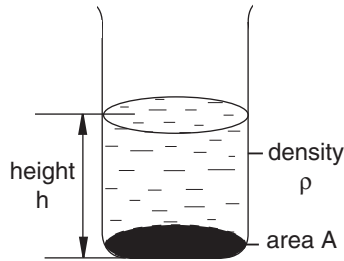

Fig. 3.10: Pressure depends on density, pull of gravity and height of liquid.

Force ( $F$ ) on area ( $A$ ) is due to the weight ( $mg$ ) of liquid above it. Given that the volume of the liquid is  $V$  and its density  $\rho$ , deduce the formula of pressure in liquid in your groups.

**Note:** You should try to derive the formula before checking the discussion given below.

Pressure exerted on area,  $A$  is given by

$$P = \frac{F}{A}. \text{ But } F = mg \text{ (weight of liquid above } A\text{).}$$

$$\therefore P = \frac{mg}{A} \text{ where } m = V\rho \text{ and since } V = Ah, m = Ah\rho$$

$$\therefore P = \frac{\rho Ahg}{A} = \rho gh$$

Hence,  $P = \rho gh$

From the above formula, we can see that pressure is directly proportional to height ( $h$ ), density ( $\rho$ ) and the pull of gravity ( $g$ ).

It is worthwhile to note that pressure in liquids does not depend on the cross sectional area,  $A$ , and the shape of the container.

Fig. 3.11 shows tubes of different shapes and different cross-sectional area. Note that the length of the liquid column,  $l$ , is the same in all the tubes.

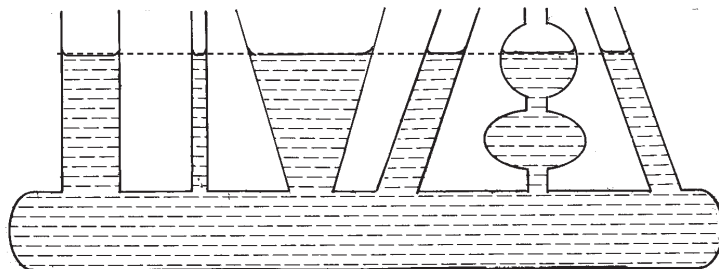

Fig 3.11: Pressure does not depend on the shape of the container

### Example 3.5

Calculate the pressure at the bottom of a beaker when it is filled with water to a height of 12 cm. Take the density of water as  $1 \text{ g/cm}^3$  and  $g = 10 \text{ N/kg}$ .

### Solution

$$\begin{aligned}
 \text{Density of water} &= 1 \text{ g/cm}^3 = 1\,000 \text{ kg/m}^3 \\
 \text{Column of water} &= 12 \text{ cm} = 0.12 \text{ m} \\
 \text{Pressure} &= \rho gh \\
 &= 1\,000 \times 10 \times 0.12 \\
 &= 1\,200 \text{ N/m}^2
 \end{aligned}$$

### Exercise 3.2

- Name three factors that affect the pressure in a liquid.
  - Describe experimentally how one of the factors in Question 1 (a) above affects pressure in liquid. What precaution(s) would be necessary?
- Explain the following statements:
  - The wall of a water reservoir is thicker at the bottom than at the top.
  - Submarines, divers and even common fish cannot descend in water beyond a certain depth.
- A column of glycerine 8.20 m high, a column of sea water 10.08 m high, column of mercury 0.76 m high and column of fresh water 10.34 m high exert the same pressure at the bottom of a container. Arrange these substances in decreasing order of their densities.
  - Calculate the pressure exerted by the column of mercury of Question 3(a) above given that the density of mercury is  $13.6 \text{ g/cm}^3$ .
- Fig. 3.12 shows two limbs of a vessel containing water. What would happen to the levels of the liquid in both limbs when the screw clip is opened?

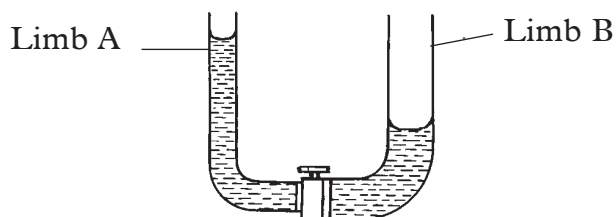

Fig. 3.12: Vessel containing water

### 3.5 Pressure in gases

#### Activity 3.9

#### To demonstrate pressure in gases

(Work in groups)

#### Materials

- A balloon
- A thread

#### Steps

1. Take a balloon provided and blow air into it. Why do you think the balloon increases in size each time you continue blowing air into balloon?
2. Tie the inflated balloon with a thread. (See Fig 3.13).



Fig 3.13 Inflated balloon

3. In your groups, discuss what air pressure is and suggest other examples that demonstrates air pressure.

The pressure of a gas is the force that the gas exerts on the walls of the container e.g. balloon. When you blow air into the balloon, the balloon expands (increases in size) because the pressure of the air molecules is greater inside the balloon than the outside. The air pressure exerted on the balloon from outside is the atmospheric pressure.

### 3.6 Transmission of pressure in fluids

Fluids are substances which are capable of flowing freely. This include all liquids and gases.

#### Activity 3.10

To show that pressure is equally transmitted through a liquid

(Work in groups)

#### Materials

- Two syringes A and B
- $m_1$  and  $m_2$
- Two stands
- A plastic tube
- Two masses

#### Steps

1. Measure the radius of two syringes A and B and find their cross-sectional areas  $A_1$  and  $A_2$  respectively.
2. Connect them as shown in Fig. 3.14. Place a mass ( $m_1$ ) on A. What do you note about the height of the two pistons? Discuss.
3. Add some mass,  $m_2$  on piston B until the two pistons are at the same level.

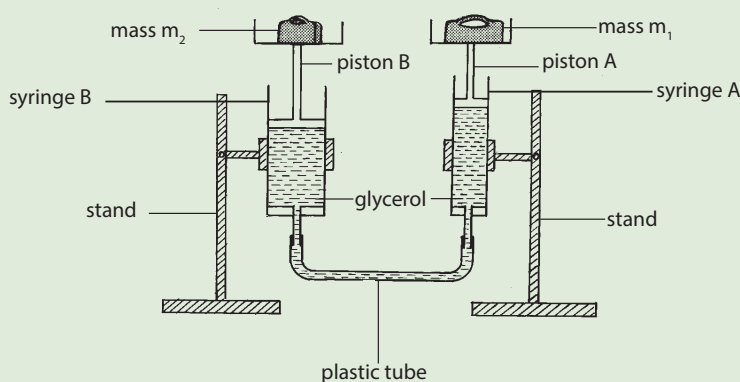

Fig. 3.14: Transmission of pressure

4. Repeat the activity with different masses on A and find the corresponding masses on B. Record the masses on A and B in a table 3.1.

Mass $m_1$ (g)	Weight of $m_1$ (N)	Mass of $m_2$ (g)	Weight of $m_2$ (N)	$P_1 = \frac{F_1}{A_1}$ (Pa)	$P_2 = \frac{F_2}{A_2}$ (Pa)

Table 3.1: Table of results

5. Calculate the corresponding weight of each mass and then calculate the pressure in each case.
6. Now, discuss with your group members how pascals principle states and the properties of the liquid used for the principle to apply.

When the two pistons are at the same level, the pressure exerted by the force due to masses A and B is equal. Pressure applied at one point in a liquid is transmitted equally to all other points of an enclosed liquid.

$$\text{Pressure, } P_1 = \text{Pressure, } P_2$$

$$\therefore \frac{F_1}{A_1} = \frac{F_2}{A_2}$$

From this activity, we can also conclude that a small force applied on a small piston produce a large force on a large piston. This is *the principle of transmission of pressure in liquids* or *Pascal's principle*.

**Pascal's principle** states that *pressure applied at a point in a fluid at rest is transmitted equally to all parts of the enclosed fluid*.

For Pascal's principle to hold, the fluid used should have the following properties:

- It should be *incompressible*
- It should *not corrode* the parts of the system.
- It should *have a wide range of temperature* i.e low freezing point and high boiling point.

### Example 3.6

The area of the large syringe in activity 6.2 is 18 cm<sup>2</sup> and that of the smaller one is 3.0 cm<sup>2</sup>. A force of 2 N is applied on the smaller piston. Find the force produced at the larger piston.

#### Solution

$$\frac{\text{Force on large piston}}{\text{Force on small piston}} = \frac{\text{Area of large piston}}{\text{Area of small piston}}$$

$$\frac{\text{Force large piston}}{2\text{N}} = \frac{18 \text{ cm}^2}{3.0 \text{ cm}^2}$$

$$\text{Force on large piston} = 2 \text{ N} \times \frac{18 \text{ cm}^2}{3.0 \text{ cm}^2}$$

$$= 12 \text{ N.}$$

### Example 3.7

Fig. 3.15 shows a hydraulic lift.

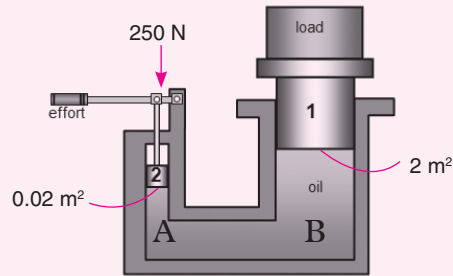

Fig. 3.15: A hydraulic lift

- (a) Determine:
- Pressure exerted on the oil by piston 1 at point A.
  - Pressure at point B.
  - Force exerted on piston 2 by the oil.
- (b) State three properties of the oil that makes it suitable for use in the hydraulic lift.

#### Solution

- (a) (i) Pressure exerted by piston 1 on the oil at point A.

$$P_1 = \frac{F_1}{A_1} = \frac{250 \text{ N}}{0.02 \text{ m}^2} \\ = 12\,500 \text{ N/m}^2$$

- (ii) Pressure exerted on to the oil by piston 1 at point A is transmitted by the oil to point B. Hence  $P_B = P_A = 12\,500 \text{ N/m}^2$

- (iii) Pressure at point B

By Pascals principle,  $P_1 = P_B$

Force exerted on the piston 2 by the oil

$$P_1 = P_B = P_2 = \frac{F_2}{A_2} \\ F_2 = P_2 \times A_2 = 12\,500 \text{ N/m}^2 \times 2 \text{ m}^2 \\ = 25\,000 \text{ N}$$

- (b) Properties of oil as a hydraulic fluid are:

- Oil is incompressible.
- Oil has a high boiling point and low freezing point.
- Oil does not corrode the parts of the system.

### Exercise 3.3

1. State Pascal's principle of transmission of pressure.
2. Define static pressure.
3. Explain why air is not commonly used as the fluid in hydraulic lift.
4. A model of hydraulic lift has pistons of diameter 1 cm and 10 cm. Find the amount of force needed to raise a load of 50 N.
5. Describe an experiment to show that pressure at a point in a liquid is distributed equally in all direction.
6. A hydraulic car jack has pistons of diameter 2 cm and 20 cm. Find the weight of a car that can be lifted by a force of 350 N.
7. Fig. 3.16 is a hydraulic system used in a garage to lift vehicles under repair.

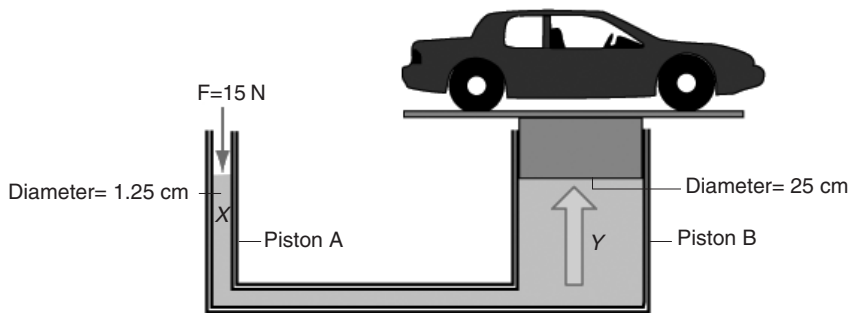

Fig. 3.16

Determine:

- (i) The pressure exerted by piston A on the fluid.
- (ii) Pressure at point Y.
- (iii) The force to lift the car.

## 3.7 Application of Pascal's principle

### Activity 3.11

To discuss the working of hydraulic brake system

(Work in groups)

#### Material

- A well drawn chart showing the hydraulic brakes system.

## Steps

1. Recall Activity 3.10 by discussing how pressure is transmitted in fluids.
2. From this activity, remind your group members how liquid is transmitted.
3. Now, using the chart provided, discuss with your group members how hydraulic jack, hydraulic brakes and hydraulic press works.
4. What is the main principle applied?

### 3.7.1: Hydraulic brakes

*Hydraulic brakes* use the principle of transmission of pressure. When a small force is applied on the brake pedal of a car, it pushes the piston in *the master cylinder*. This produces pressure that is equally transmitted to the pistons in the *slave cylinder* (Fig. 3.17).

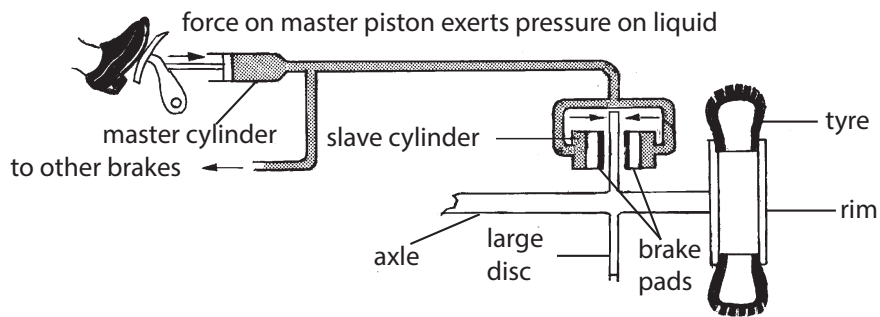

Fig. 3.17: Hydraulic brakes

The pressure forces the brake pads to come into contact with the large disk and slows or stops the car. On releasing the foot pedal, the unbalanced pressure in the slave cylinder forces the liquid back into the master cylinder. Consequently the disk is released.

The pistons in the master cylinder are usually smaller in diameter than the pistons in the slave cylinder, hence a small force applied on the brake pedal produces a large force on the pistons in the slave cylinder.

### Hydraulic jack

Hydraulic jack works on the principal of fluid transmission to lift heavy loads. They use pumb plungers to move all through two cylinders.



## 3.8 Atmospheric pressure

Atmospheric pressure is the pressure resulting from the weight of the air column acting on the earth's surface. In this unit, will start by carrying out activities to demonstrates the existence of atmospheric pressure, discuss factors influencing the pressure, instruments used to measure the pressure then discuss the application of atmospheric pressure.

### 3.8.1 Existence of atmospheric pressure

#### Activity 3.12

To illustrate the existence of atmospheric pressure

#### Materials

- A thin walled can
- A glass tumbler
- A cardboard
- Water
- A cork
- Source of heat

#### Steps

1. Fill a glass tumbler with water and cover the top with a cardboard (Fig. 3.18(a)).
2. Invert the tumbler while holding the cardboard (Fig. 3.18(b)). Suddenly remove the hand holding the cardboard. Does the cardboard fall? Does the water come out? Explain your onservation.
3. Now, turn the tumbler side ways (Fig. 3.18(c). What do you observe?
4. Suddenly remove the cardboard covering the tumbler. What happens to the water inside the tumbler? Explain.

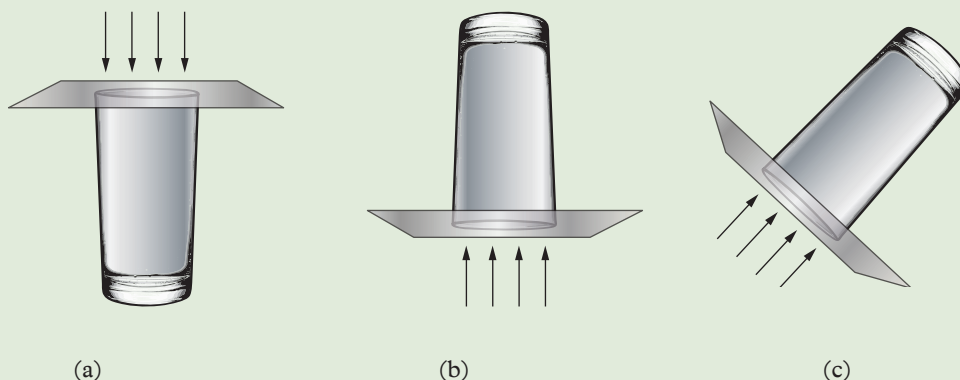

Fig. 3.18: Demonstrating atmospheric pressure using a glass tumbler

5. Now pour some water in a large thin-walled can.
6. Boil off the water in the can and immediately cork the can.
7. Allow it to cool. Why does the can crush?
8. Do you think you would make the same observation if it was allowed to cool without corking it? Explain.
9. Explain how atmospheric pressure acts on the tumbler and the can?

You should have observed that the cardboard does not fall when the glass is inverted vertically upwards or sideways. This takes place because the pressure due to the column of air in the atmosphere (i.e. atmospheric pressure) is greater than the combined pressure due to the column of water and air inside the glass. Hence atmospheric pressure keeps the cardboard intact. The water does not flow out.

Before the can in this activity is heated and corked, the air inside and outside the can exerts pressure equally on the walls of the container that balances with atmospheric pressure (Fig. 3.19(a)).

When the can is heated (Fig. 3.19 (b)), the steam that is formed expels the air inside the can. After cooling the can, the steam condensed and a partial vacuum is formed inside (Fig. 3.19 (c)). The air pressure inside the can decreases. The atmospheric pressure acting on the surface of the can from outside is greater than the air pressure inside. It therefore makes the can to crush or collapse inward as shown in Fig. 3.19 (c).

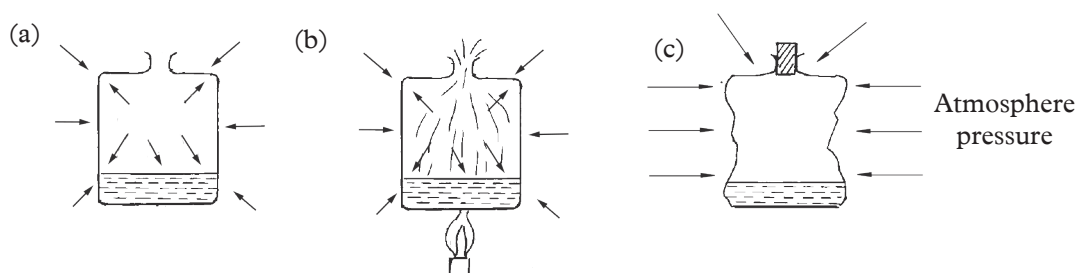

Fig. 3.19: Demonstration of atmospheric pressure

## 3.8.2 Factors influencing atmospheric pressure

### Activity 3.13

To find out factors that influence atmospheric pressure

#### Materials

- Internet enabled computers
- Reference books

#### Step

1. Suggest the factors that influence atmospheric pressure.
2. Explain to your classmates how the factors you have suggested in step 1 influence atmospheric pressure.
3. Now conduct a research from the internet or reference books on why do weather forecasts focus on areas of high altitude and how this influence the weather. Write them down.
4. In your research, find out why athletes prefer training at high altitudes.
5. Give a summarised presentation on your findings to the whole class through your secretary.

#### (a) Altitude

The main factor that affects atmospheric pressure at a given location is the altitude (or height above sea level) of the location. The maximum air density is at the earth's surface. The air density decreases with the height away from the surface of the earth (See Fig. 3.20).

This is because the pull of the earth's gravity on the air is less.

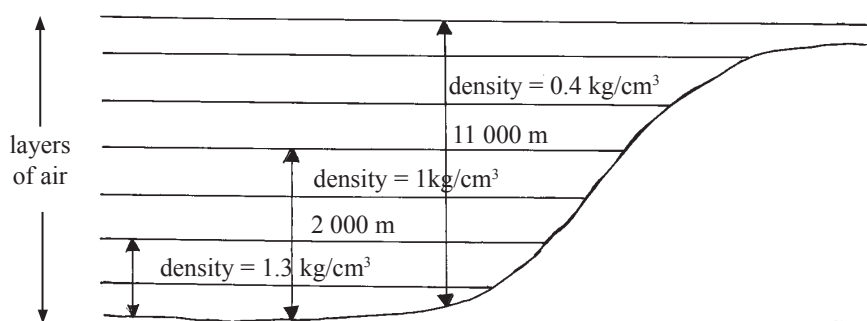

Fig. 3.20: Atmospheric pressure varies with altitude

The fewer number of gas molecule at higher altitude means fewer molecular collisions and a decrease in atmospheric pressure.

### **(b) Temperature**

When atmospheric air is heated (such as by radiation from the sun), the air molecules become active. The space between the neighbouring air molecules increases and reduces air density. Lowering the air density decrease the amount of pressure exerted by the air i.e. atmospheric pressure. Therefore, given equal volume of air, warm air is less dense than cold air and exert less pressure.

### **(c) Water vapour concentration (humidity)**

When water evaporates into the atmosphere its molecules take the place of gas molecules in the air. The water vapour is less denser than dry air. Hence, wet air being less dense exerts less pressure than dry air. Therefore, atmospheric pressure decreases with increase of humidity (water vapour in the atmosphere).

### **(d) Wind Pattern**

Atmospheric pressure is also influenced by wind patterns. Winds causes convergence (moving together) and divergence (moving apart) of air at the earth's surface. When the wind converges, air molecule increases exerting more pressure on the surface whereas it exerts less pressure when the wind diverges since air molecules decrease in number.

#### **Exercise 3.4**

- 1.** List four factors that influences atmospheric pressure.
- 2.** Explain why it is difficult to cook food while on top of a mountain.
- 3.** Briefly explain why international athletes often travel to Ethiopia for practice.
- 4.** Discuss how the temperature and wind patterns affects atmospheric pressure.
- 5.** A student in senior three started nose bleeding while they were in a trip at the top of Mt. Imatong.
  - (a)** Explain the possible reason for his/her nose bleeding
  - (b)** Do you think the student would experience the same if they were in the low lands around the white Nile?
  - (c)** Discuss how you can help him/her to stop nose bleeding.

### 3.8.3 Measurement of atmospheric pressure

#### Activity 3.14

To measure atmospheric pressure using mercury barometer

#### Material:

- Mercury barometer

#### Caution

Mercury barometer is heavy, fragile and expensive. Care must be taken when handling it.

#### Steps

1. Take the mercury barometer provided and observe its calibrations. What is the height of the column of mercury in it? Record it down.
2. Tell your classmate why mercury is used as a barometric liquid and not water.
3. Predict what will happen to the level of the mercury as you climb up a high mountain. Explain.
4. Discuss with your group members other instruments used to measure atmospheric pressure apart from the mercury barometer.
5. Give a summarised report on your findings to the whole class in a class discussion.

#### Mercury Barometer

A mercury barometer consists of a thick-walled glass tube, which is closed at one end. The tube is completely filled with mercury and inverted repeatedly to remove air bubbles. The tube is then completely filled again with mercury and inverted into a trough containing mercury.

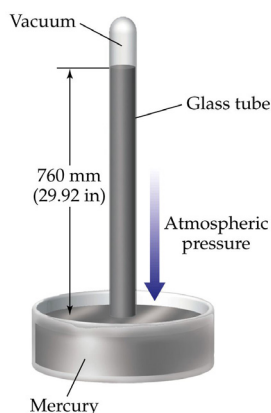

Fig. 3.21: Mercury barometer

The mercury column drops until it reaches a height of 76 cm above the lower level of the mercury meniscus (see Fig. 3.21) if the barometer is at sea level.

When the barometer is placed in a region with lower atmospheric pressure e.g. high on the mountain, the height of the mercury column in the tube drops to a level showing the atmospheric pressure at that place.

This barometer can be used in the laboratory or weather station, but it is not easy to move it from one place to another.

Other instruments for measuring pressure are: Fortin barometer and Aneroid barometer.

### Exercise 3.5

1. Name a liquid that is used for constructing instruments that measures atmospheric pressure. Give a reason why the liquid is preferred over others.
2. Describe how you can measure atmospheric pressure at the top of a mountain.
3. Describe the working of:
  - (a) Mercury barometer.
  - (b) Aneroid barometer.
4. Explain how you can test for the vacuum in a barometer.
5. The atmospheric pressure in a particular day in Juba was measured as 740 mmHg. Express this  $\text{Nm}^{-2}$ . (Assume density of mercury is  $13600 \text{ kgm}^{-3}$  and  $g = 10 \text{ N/kg}$ )
6. A senior three student plans to make a barometer using sea-water of density  $1025 \text{ kgm}^{-3}$ . If the atmospheric pressure is  $104\,000 \text{ Nm}^{-2}$ , what is the minimum length of the tube that the student will require? (Take  $g = 10 \text{ N/kg}$ )

### 3.8.4 Applications of atmospheric pressure

#### Activity 3.15

To demonstrate some applications of atmospheric pressure

#### Materials

- Drinking straw
- Rubber sucker Glass

- Empty beakers
- Syringe
- Drinking water

### Steps

1. Take a drinking straw provided to you and dip it in the glass with clean drinking water.
2. Sip the water using the straw. What makes the water to rise up the straw?
3. Dip the nozzle syringe in the water. Draw its piston. What makes the water to flow into the barrel?
4. Explain how atmospheric pressure acts in the observation you have made in step 2 and 3.
5. Now, discuss with your classmates how a rubber sucker, syringe and lift pump work.
6. Note down the main points from your discussion.
7. Give a summarized report on your findings to the whole class through a discussion.

### (a) Drinking straw

Sucking through a straw reduces the air pressure inside the straw. The atmospheric pressure forces the water into your mouth through the straw (Fig 3.22).

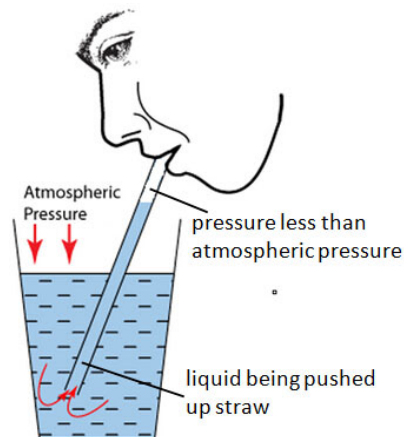

Fig. 3.22: Drinking straw

### (b) Syringe

When the piston is pulled (upstroke) the pressure inside reduces and the atmospheric pressure on the surface of the liquid pushes the liquid into the barrel. During a downstroke, the pressure inside increases and the liquid is expelled from the barrel.

### (c) Lift pump, force pump and the bicycle pump

These are devices which use the principle of pressure difference created to raise water to a higher level or to force air into the tyre of a bicycle respectively.

Since atmospheric pressure can only support a water column of about 10 m, a lift pump cannot raise water above a height of 10 m. The situation becomes even worse when the pump is used in areas well above sea level where atmospheric pressure is low.

### (d) Siphon

The pressure difference created by the siphon (a flexible tube used to remove the liquid from a fixed container to the outside lower container) forces the liquid to come out.

### Exercise 3.6

1. Explain the action of a drinking straw.
2. Draw and explain the features of a siphon.
3. Explain how a rubber sucker and vacuum cleaner works.
4. Draw and explain the function of a syringe.
5. What is the function of the compressed air in the force pump?
6. (a) What is atmospheric pressure?  
(b) Atmospheric pressure increases with decrease in altitude. Why is this so?  
(c) Describe two activity that can describe the effect of atmospheric pressure.
7. State two instruments used to measure atmospheric pressure.
8. Fig. 3.23 alongside shows a simple mercury barometer.

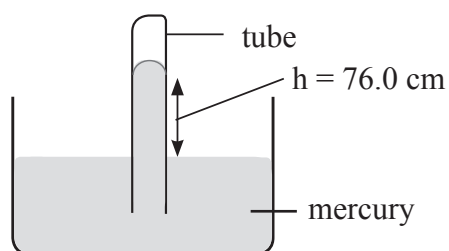

Fig. 3.23

Use it to answer the questions that follow.

- (a) What does it measure?
- (b) What properties of mercury make it a suitable liquid to use in a barometer?



- (c) What occupies the space above mercury in the tube?
- (d) The mercury in the barometer is warmed.
- (i) What will be the effect on the density of mercury?
  - (ii) Considering that the atmospheric pressure remained constant, how does the change in density in (i) above affect the height of the mercury column? (Assume expansion of glass is negligible)
9. With a well drawn diagram, describe how aneroid barometer is used to measure atmospheric pressure
10. (a) What is a manometer?
- (b) With a well drawn diagram, describe an activity to show how a manometer is used to measure pressure.

### Topic summary

- Pressure is defined as a force acting perpendicularly on a unit area.
- $P = \frac{F}{A}$ . The SI unit of pressure is pascal. 1 pascal is equal to 1 N/m<sup>2</sup>.
- Pressure in liquids depend on:
  - (a) the density of liquid ( $\rho$ )
  - (b) the height of column of liquid ( $h$ )
- The formula for pressure in a liquid is given by,  $p = h\rho g$
- Pascal's principle states that the pressure applied at one point in an enclosed fluid at rest is transmitted equally to all parts of the fluid.
- Atmospheric pressure is the pressure due to the column of air above the surface of the earth.
- Factors that influence atmospheric pressure include
  - (i) Altitude
  - (ii) Temperature
  - (iii) Water vapour concentration (Humidity)
  - (iv) Wind pattern
- Atmospheric pressure decreases with the increase in altitude.
- Atmospheric pressure decreases with increase in air temperature.
- Atmospheric pressure increases with convergence of winds and decreases with divergence of winds.

- Instruments used to measure atmospheric pressure include:-
  - (i) Mercury barometer
  - (ii) Fortin barometer
  - (iii) Aneroid barometer
- Some of the situation in which atmospheric pressure is applied include:
  - (i) When using a drinking straw
  - (ii) When using a Syringe
  - (iii) When siphoning liquids
  - (iv) When cleaning using a vacuum cleaner
  - (v) When hanging clothes using a rubber sucker on a smooth wall
  - (vi) In an automatic flushing unit

### Topic Test 3

1. A wooden cube of side 2 cm has a mass of 3.2 g Calculate:
  - (a) the weight of the wood.
  - (b) the pressure it would exert on a flat horizontal surface.
2. A block of iron measures 6 cm long, 8 cm wide and 1.0 cm deep and has a mass of 360 g. Calculate
  - (a) the block's minimum and maximum area.
  - (b) the greatest pressure it can exert on a flat horizontal surface.
3. A car's four tyres, each of area  $0.06 \text{ m}^2$ , are in contact with the road. Calculate the pressure exerted by each tyre if the car has a mass of 1 200 kg.
4. The maximum pressure a glass slab would exert on a flat horizontal ground is  $5\,000 \text{ N/m}^2$ . Calculate the mass of the glass slab if it measures  $20 \text{ cm} \times 10 \text{ cm} \times 5 \text{ cm}$ .
5. A metal cube of mass 68 kg exerts a pressure of 17 000 pa on a flat horizontal ground. Calculate:
  - (a) the area in contact with the ground.
  - (b) the dimension of the cube.

6. Explain the following:
  - (a) a hippopotamus walks in a swampy area without sinking but a person who is lighter sinks.
  - (b) trucks carrying heavy cargoes have many wheels.
7. In Hare's apparatus, the height of water column in one tube is 80 cm and the oil column in the other tube is 1.0 m. Calculate the density of oil used, if density of water is  $1\,000\text{ kg/m}^3$ .
8. Explain the floating and sinking phenomena using density.
9. A diver is swimming 102m below the surface of sea water. Calculate the pressure experienced by the diver at this level. (Take density of sea water to be  $10300\text{ kg/m}^3$  and  $g = 10\text{ N/kg}$ )
10. (a) Define the relative density.  
 (b) The density of milk is  $1.03\text{ g/cm}^3$ , while its relative density is 1.03. What is the density of water in its SI unit?
11. Find the pressure at point P at the centre of the base of the bucket shown in Fig. 3.24 below. (Take the density of water =  $1\,000\text{ kg/m}^3$  and  $g = 10\text{ N/kg}$ )

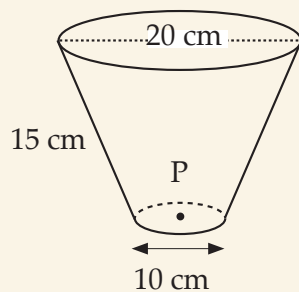

Fig. 3.24

12. Use the words given to fill in the spaces.  
*atmosphere, barometer, atmospheric, density*  
 Earth surface is surrounded by a thick layer of air called \_\_\_\_\_. The \_\_\_\_\_ of air varies on earth's surface to the outer place. The pressure exerted by air is called \_\_\_\_\_ pressure and its measured using an instrument called \_\_\_\_\_.
13. State and briefly explain three factors that influence atmospheric pressure.
14. The air pressure at the base of a mountain is 76.0 cm of mercury while at the top it is 43.0 cm of mercury. Given that the average density of air is  $1.25\text{ kg m}^{-3}$  and the density of mercury is  $13600\text{ kg m}^{-3}$ , calculate the height of the mountain.

15. Describe briefly how an automatic flushing unit operates.
16. Explain how you can use mercury barometer to measure atmosphere pressure in your school.
17. Outline and briefly discuss four applications of atmospheric pressure in our daily lives.
18. Explain how altitude affects atmospheric pressure.

# Effects of temperature change on matter

## Topics in the unit

Topic 4: Effects of temperature changes on matter

## Learning outcomes

### Knowledge and Understanding

- Understand the effects of temperature changes on matter

### Skills

- Observing carefully
- Predict what might happen
- Use appropriate measures
- Collect and present results appropriate in writing or drawing
- Interpret results accurately
- Report findings appropriately

### Attitudes

- Show curiosity in carrying experiments.

### Key inquiry questions

- How do different types of thermometers function?
- How do dimensions of objects change as a result of temperature?
- What determines whether a substance is a gas, a liquid or a solid?
- How does the temperature affect objects?
- Why are fixed points necessary in order to establish a thermometer scale?

## Effects of temperature changes on matter

### Topic outline >>>

- Heat as a form of energy.
- Difference between heat and temperature.
- Temperature scales.
- Types of thermometers.
- Measurement of temperature of substances.
- Thermal equilibrium.
- Functioning of thermometers.
- Liquid for thermometers.
- Temperature conversion.
- Effect of solutes on boiling points of liquids.

### Introduction

Heat and temperature pervade our lives. Just think about it. We give attention to hotness and coldness in deciding what to eat or drink and what to wear during the day or at night.

Our bodies are highly sensitive to hot and cold environments. We learn very early in life through the school of pain that we shouldn't touch a hot pot on the stove or a hot lamp. In the same school, we learnt that we should be careful about mouthing or tasting hot foods. We also learnt how to use our hands to feel the heat that emanates from such foods and how to blow gently on them to help cool the food down.

In this topic, we are going to learn more about temperature and how to measure it using different instruments.

## 4.1 Heat as a form of energy

### Activity 4.1

#### To demonstrate effect of hot water on ice

(Work in groups)

#### Materials:

- Ice
- A bowl
- Hot water

#### Steps

1. Put some ice in a bowl.
2. Feel the bowl with the palm of your hand. What do you feel?
3. Pour hot water into the bowl containing ice.
4. Wait for sometime and again feel the container. What can you conclude?
5. Now, discuss with your members what temperature and heat energy are and suggest an instrument used to measure temperature .
6. Present your findings to the whole class through your secretary.

Heat is a form of energy which passes from a body at high temperature to a body at low temperature. The SI unit of heat is the joule (J). Temperature is the *degree of hotness or coldness of a body or a place*. The SI unit of temperature is Kelvin (K) In Activity 4.1, the fact that the bowl feels warmer, means that temperature has increased. This suggests that ice and bowl have gained heat energy. Temperature is measured using a device called **thermometer** while heat is measured using **thermol imaging (infra-red) instrument**.

## 4.2 Temperature scales

### Activity 4.2

#### To observe temperature scales

#### Materials

- Internet
- Reference books or resource persons.

#### Steps

1. Conduct research from the Internet, books resource persons and any other relevant reading materials including this book, on:
  - (a) The different types of temperature scales.
  - (b) How the scales of the thermometers are graduated.

- (c) Maximum and minimum temperature values on the scale and what they are called.
2. Ensure that you have a group leader to write the main points on the research after discussion.
3. Compare your findings with other groups in class. What do you notice? Do you have same conclusion?
4. Discuss your findings and have a final report to be presented to the whole class by the group secretary.

A temperature scale is a range of values for measuring the degree of hotness or coldness referred to as temperature. Temperature is commonly expressed in *degrees Celsius* (also called *degrees centigrade*) using the Celsius scale. However, the **SI unit** for temperature is the *Kelvin (K)* which is measured using the *Kelvin scale*. This is the unit that is used in scientific work. Another scale used for measuring temperature scales is the *Fahrenheit*. Let us discuss each of these scales in details.

#### 4.2.1 The Celsius scale

This scale uses the *degree Celsius (°C)* as the unit of measuring temperature. Two values in this scale are fixed such that the temperature at which pure ice melts is  $0^{\circ}\text{C}$  and boiling point of pure water is  $100^{\circ}\text{C}$  (under standard atmospheric pressure of 101 325 Pa).

These two fixed points are called the *lower* and *upper fixed points* of the Celsius scale respectively. The region between these two points on the scale (called fundamental interval) is graduated into 100 equally spaced temperature marks (Fig 4.1). Temperatures below  $0^{\circ}\text{C}$  have negative (-) values.

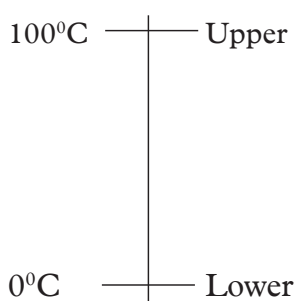

Fig 4.2: Celsius scale

#### 4.2.2 The Kelvin scale

This scale uses *Kelvin (K)* as the unit of measuring temperature. The scale uses the absolute zero ( $-273^{\circ}\text{C}$ ) as its reference point. Thus, 0 K on Kelvin scale is equivalent to  $-273^{\circ}\text{C}$  on the Celsius scale. At absolute zero, a hypothetical



temperature, all molecular movement stops all actual temperatures are above absolute zero. It is worth noting that a temperature change of 1 K is equal in size to a change of 1°C.

### 4.2.3 Fahrenheit

This scale uses *degree Fahrenheit (°F)* as the unit of measuring temperature. Two values in this scale are fixed such that the temperature at which water freezes into ice is defined as 32°F and the boiling point of water is defined to be 212°F. The two have a 180°F separation (under standard atmospheric process) Fig. 4.2 shows a Fahrenheit scale.

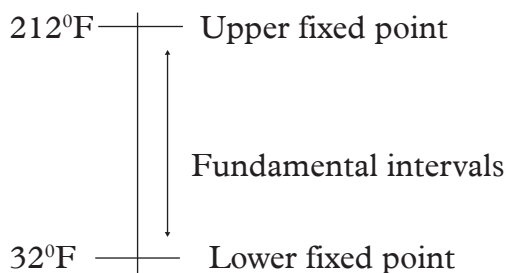

Fig. 4.2: Fahrenheit scale

### 4.2.5 Conversion of temperature from one scale to another

#### Activity 4.3

#### To convert from one temperature scale to another

#### Materials

- Internet
- Reference books
- Resource persons

#### Steps

1. Conduct research from internet, reference books and any other relevant reading materials on the following: This book may be of help but you need other reference books to get more conversion questions.
  - (a) How temperature is converted from:
    - (i) Celsius to Kelvin scale.
    - (ii) Celsius to Fahrenheit scale.
    - (iii) Fahrenheit to Kelvin.
  - (b) Note down the formula of converting temperature from one scale to the other in each case in 1 (a).
2. By use of examples, present to the class on how to convert temperature from one scale to the other.

### (i) Relationship between Celsius and Kelvin scale

To convert temperature from degree Celsius ( $^{\circ}\text{C}$ ) to Kelvin temperature (K), we add 273 to degrees temperature i.e.

$$\begin{aligned} \text{Temperature in K} &= \text{temperature in } ^{\circ}\text{C} + 273 \\ T_{(\text{K})} &= (T_{(^{\circ}\text{C})} + 273)\text{K} \end{aligned}$$

To convert Kelvin (K) temperature to degrees Celsius ( $^{\circ}\text{C}$ ) temperature, we subtract 273 from Kelvin temperature i.e.

$$\begin{aligned} \text{Temperature in } ^{\circ}\text{C} &= \text{temperature in K} - 273 \\ T_{(^{\circ}\text{C})} &= (T_{(\text{K})} - 273)^{\circ}\text{C} \end{aligned}$$

Fig. 4.4 shows a summary of the relationship between Kelvin scale and Celsius scales.

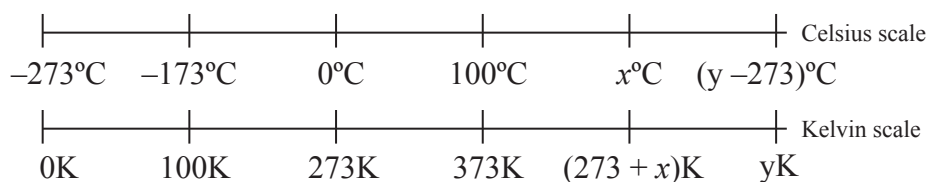

Fig. 4.4: Relationship between Kelvin and Celsius scale

In this case;  $x$  is any value of temperature in degrees Celsius and  $y$  is any value of temperature in Kelvin.

**N.B:** The lower fixed point (ice point) is the temperature of pure melting ice at normal atmosphere measure. The upper fixed point (steam point) is the temperature of pure boiling water at normal atmosphere pressure.

#### Example 4.1

What is the lower fixed point (L.F.P) in Kelvin?

#### Solution

Lower fixed point is  $0^{\circ}\text{C}$ . To convert  $^{\circ}\text{C}$  to Kelvin, add 273.

Therefore, L.F.P =  $(0^{\circ}\text{C} + 273)\text{K} = 273 \text{ K}$ .

**Example 4.2**

Express the room temperature of 27°C in Kelvin.

**Solution**

To convert °C to Kelvin, add 273.

Therefore, room temperature is  $(27 + 273)\text{K} = 300 \text{ K}$ .

**Example 4.3**

Convert 327 K to degrees Celsius.

**Solution**

To convert Kelvin to degrees Celsius, subtract 273.

Therefore,  $327 \text{ K} = (327 - 273) \text{ °C} = 54\text{°C}$ .

**(b) Relationship between Celsius and Fahrenheit**

To convert Fahrenheit into Celsius, we subtract 32 and then multiply by  $\frac{5}{9}$  i.e

$$T_{\text{(°C)}} = [T_{\text{(°F)}} - 32] \times \frac{5}{9}$$

**Example 4.4**

Convert 42 Fahrenheit to Celsius scale.

**solution**

$$\begin{aligned} T_{\text{(°C)}} &= [T_{\text{(°F)}} - 32] \times \frac{5}{9} = (42-32) \times \frac{5}{9} \\ &= \frac{50}{9} \\ &= 5.56\text{°C} \end{aligned}$$

To convert Celsius to Fahrenheit, we multiply by  $\frac{9}{5}$  then add 32 i.e.

$$T_{\text{(°F)}} = T_{\text{(°C)}} \times \frac{9}{5} + 32$$

**Example 4.5**

Convert 37 degree Celsius to degree Fahrenheit.

**Solution**

$$\begin{aligned}T_{(^{\circ}\text{F})} &= T_{(^{\circ}\text{C})} \times \frac{9}{5} + 32 = [37 \times \frac{9}{5}] + 32 \\ &= 98.6 \text{ } ^{\circ}\text{F}\end{aligned}$$

**(c) Relationship between Fahrenheit and Kelvin**

To convert Fahrenheit to Kelvin, we add 454.67 then multiply by  $\frac{5}{9}$  i.e.

$$T_{(\text{K})} = (T_{(^{\circ}\text{F})} + 454.67) \times \frac{5}{9}$$

**Example 4.6**

Convert 22 degree Fahrenheit to Kelvin.

**Solution**

$$\begin{aligned}T_{(\text{K})} &= (T_{(^{\circ}\text{F})} + 454.67) \times \frac{5}{9} \\ &= (22 + 454.67) \times \frac{5}{9} \\ &= 481.67 \times \frac{5}{9} \\ &= 267.59 \text{ K}\end{aligned}$$

**(d) Kelvin to Fahrenheit**

To convert Kelvin to Fahrenheit, we multiply by  $\frac{9}{5}$  then subtract 454.67. i.e

$$T_{(^{\circ}\text{F})} = (T_{(\text{K})} \times \frac{9}{5} - 454.67)$$

**Example 4.7**

Convert 302 Kelvin to Fahrenheit scale.

**Solution**

$$\begin{aligned}T_{(^{\circ}\text{F})} &= T_{(\text{K})} \times \frac{9}{5} - 454.67 \\ &= 302 \times \frac{9}{5} - 454.67 \\ &= 543.6 - 454.67 \\ &= 83.93 \text{ } ^{\circ}\text{F}\end{aligned}$$

### Exercise 4.1

1. Differentiate between heat and temperature. State their SI units.
2. Describe an experiment to differentiate between heat and temperature.
3. Name two fundamental intervals in a temperature scale.
4. Convert each of the following into Kelvin scale.  
(a)  $34\text{ }^{\circ}\text{C}$       (b)  $-271\text{ }^{\circ}\text{C}$       (c)  $17\text{ }^{\circ}\text{C}$
5. Convert each of the following into degrees Celsius.  
(a)  $314\text{ K}$       (b)  $-6\text{ K}$       (c)  $273\text{ K}$       (d)  $6\text{ K}$
6. Convert each quantities in question 4 and 5 into Degree Fahrenheit.

### 4.3 Thermal equilibrium

#### Activity 4.4

#### To investigate thermal equilibrium

##### Materials

- Source of heat
- Cold water
- Two beakers
- Thermometer

##### Steps

1. Pour cold water into a beaker and place it on a source of heat for 30 min then measure the temperature  $T_1$ .
2. Now put equal amount of some cold water in another beaker and measure its temperature  $T_2$ .
3. Mix the warm water and cold water into one of the beaker and stir well.
4. After stirring, measure the temperature  $T_3$  of the mixture. What name is given to temperature  $T_3$ ?
5. Do you think temperature  $T_3$  have a relationship with  $T_1$  and  $T_2$ ? Explain.
6. From your understanding how are human beings able to avoid reaching an equivalence of temperature  $T_3$  in cold or hot environment.

Thermal equilibrium is the state achieved when two regions or substances that are in thermal contact no longer transfer heat between them. Therefore, two substances in thermal equilibrium are at the same temperature. For example, when measuring the human body temperature, heat energy is transferred from the human body to the liquid inside the thermometer until the two (i.e. human body and thermometer) have the same temperature e.g.  $37^{\circ}\text{C}$  in thermal equilibrium.

## 4.4 Measurement of temperature

We learnt that temperature is the degree of hotness or coldness of an object. It is measured using an instrument called **thermometer**.

In the construction of a thermometer, a thermometric substance is chosen first. Then, a temperature scale is defined by means of two fixed points; lower and upper.

### 4.4.1 Thermometric substances

#### Activity 4.5

To define and discuss thermometric substances

#### Materials

- Reference books
- Internet
- Resource persons

#### Steps

1. Conduct research from Internet and reference books on thermometric substances.
2. In your research find out:
  - (a) Some of the common thermometric substances used in thermometers. Why are they used?
  - (b) Advantages and disadvantage of using each of the thermometric substances identified in (a) above.
3. Compare and discuss your findings with other groups in class.
4. Let one of the group member give a presentation on your findings to the rest of the class.

There are different thermometric substances used in different thermometers. Their properties changes uniformly with temperature.

#### 4.4.1.1 Thermometric properties

Some important characteristics of thermometric substances are:

1. The property should remain constant, if temperature is constant.
2. The property should change uniformly with change in temperature.
3. The property should change uniformly for every 1°C change in temperature.
4. The property should acquire thermal equilibrium as quickly as possible, when temperature measurements are needed.
5. The property should cover a wide range of temperatures (should not freeze or boil at normal temperatures).

6. The property should be able to register the rapid changing temperature.
7. The property should have a large change even if the change in temperature is small.
8. The property should be such that the temperature can be taken easily without waiting for a long time.

Some of the common thermometric substances used in thermometers include **mercury** and **alcohol**.

#### **4.5.1.2 Mercury as a thermometric liquid**

##### **Advantages of using mercury as a thermometric substance**

1. Mercury is a shiny and opaque liquid. The position of the mercury meniscus is seen easily and readings taken without strain.
2. Mercury does not wet glass. Hence it does not stick to the sides of the capillary tube.
3. Mercury has a large increase in volume for 1°C rise in temperature.
4. Mercury expands uniformly. Its volume changes by equal amounts for equal change in temperature.
5. Mercury has a high boiling point of 357°C.
6. Mercury has the ability to transfer heat energy easily. The whole mass of mercury in the bulb attains the temperature of the substance in which the bulb is placed easily.

##### **Disadvantages of mercury as a thermometric substance**

1. Usually, it is only the bulb which is in contact with the body when taking the temperature. A large portion of the stem is not in contact with the body.
2. There is a change in internal pressure due to the different positions of the thermometer. The reading of the mercury level is low when the tube is vertical as compared to the reading in the horizontal position.
3. Mercury takes sometime to contract to the original volume. The same thermometer cannot be used to measure a low temperature soon after a high temperature.
4. There may be non-uniformity in the capillary bore of the tube.
5. This thermometer is not suitable to measure temperatures below -39°C.

### 4.4.1.3 Alcohol as a thermometric substance

#### Advantages of using alcohol as a thermometric substance

1. Alcohol has a very low freezing point of  $-114^{\circ}\text{C}$  hence its suitable in thermometers to record very low temperatures.
2. Alcohol can be coloured brightly (by adding a dye, generally red dye). This makes it clearly visible through glass.
3. Alcohol has a uniform expansion and contraction than mercury.
4. Alcohol is a good thermal conductor; it is also cheap and easily available.

#### Disadvantages of using alcohol as a thermometric substance

1. Alcohol sticks to the walls of the glass thus wetting it. This makes it difficult to read the temperature accurately.
2. Alcohol has a low boiling point of  $78^{\circ}\text{C}$ , therefore it cannot be used to measure high temperature.

## 4.5 Types of thermometers

### Activity 4.6

#### To identify different types of thermometers

#### Materials

- Reference books
- Internet
- Resource persons

#### Steps

1. Conduct research from internet or reference books on types of thermometers.
2. In your research, identify the main features of each thermometer, how it is calibrated and how it is used to measure temperature of a body or a place.
3. Compare and discuss your findings with other groups in your class.

There are various types of thermometers in use. The **liquid-in-glass** thermometer is the most common one. Others include **electrical, digital** and **gas thermometers**. The main difference between them is in the property of the thermometric substance. In this level we shall discuss liquid-in-glass thermometers only.



## 4.5.1 Liquid-in-glass thermometers

### Activity 4.7

To observe the working of mercury and alcohol in glass thermometers

#### Materials

- Mercury and alcohol - in- glass thermometers
- Hot water in a beaker

#### Steps

1. Hold the thermometers provided to you and note down the following:
  - (a) The range of their scales.
  - (b) Minimum and maximum values on the scales.
  - (c) Some features of the thermometers and suggest some precautions to be taken when constructing it.
  - (d) Note the kind of the liquids used.
2. Now, place it in hot water and measure the temperature of the water. Record down your result. Are you able to take the reading?

**Note:** The temperature of the hot water should not exceed  $78^{\circ}\text{C}$  when using the alcohol in glass thermometer. Why do you think this should be so?
3. Discuss in your group how the thermometer is used.
4. Compare and discuss your findings with other groups in class.

Liquid-in-glass thermometer uses either mercury or coloured alcohol as the thermometric substance. They include laboratory (i.e mercury-in-glass and alcohol-in-glass) thermometers, clinic thermometer and six's maximum and minimum thermometer.

### Mercury-in-glass thermometer

This thermometer consists of a *thin walled bulb*, containing mercury and a thin *capillary tube (bore)* of uniform cross-sectional area. There is a space above mercury thread which is usually evacuated to avoid excess of pressure being developed when mercury expands (Fig. 4.4).

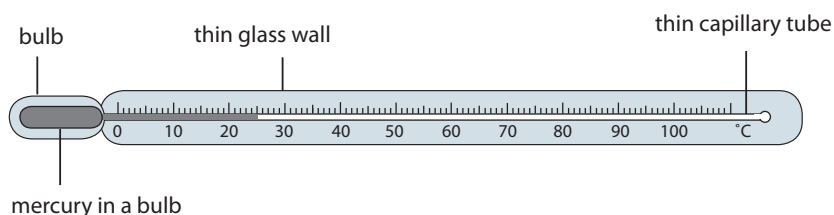

Fig. 4.4: Mercury-in-glass thermometer

Some important precautions are taken in the construction of this type of thermometer include:

- (a) The walls of the bulb should be thin. This is to ensure that the mercury can be heated easily.
- (b) The quantity of mercury in the bulb should be small so that the mercury takes little time to warm up.
- (c) The thin capillary tube should be of uniform cross-section so that the mercury level changes uniformly along its length.

#### 4.5.2 Alcohol-in-glass thermometer

The alcohol-in-glass thermometer uses coloured alcohol instead of mercury. Volume of alcohol changes uniformly and easily when heated. The change in volume of alcohol is about six times more than that of mercury for the same change in temperature.

The range of temperatures that can be measured with this thermometer is limited, as alcohol boils at  $78^{\circ}\text{C}$ . However this thermometer is ideal for measuring low temperatures since alcohol freezes at  $-114^{\circ}\text{C}$ .

#### Using a laboratory thermometer

Before using a laboratory thermometer, you should note its initial reading (i.e. room temperature reading) and while measuring temperature, ensure that its bulb is always in contact with the substance whose temperature is to be measured. Avoid direct heating of the bulb.

#### Clinical thermometer

##### Activity 4.8

##### To observe the working of a clinical thermometer

**Material:** Clinical thermometer

##### Steps

1. Hold the thermometer provided to you and note the following:
  - (a) the range of the scale.
  - (b) minimum and maximum values on the scale.
  - (c) features of the thermometer.
2. Now, note the reading of the thermometer and place it in your armpit for a couple of minutes.

3. While still in the armpit, note the reading where the liquid becomes steady. What is the value? Record it down.
4. Compare and discuss your findings with other groups in class.

A clinical thermometer is designed for measuring the human body temperature. It consists of a thin walled bulb containing mercury. The capillary bore is very narrow and of uniform diameter.

This thermometer has a narrow *constriction* in the tube just above the bulb. The thermometer has a limited range from about 35°C to about 43°C (Fig. 4.5).

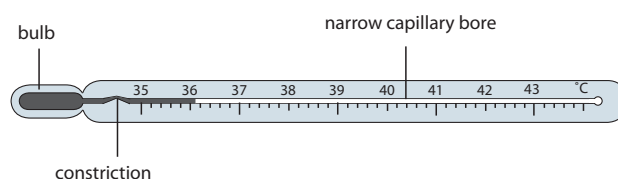

Fig. 4.5: Clinical thermometer

### Working of a clinical thermometer

When the thermometer is in contact with a human body, mercury in the bulb expands. It forces its way through the constriction to the narrow bore. When the thermometer is removed from the body, the mercury in the bulb cools down and contracts. The mercury thread is broken at the constriction (Fig. 4.6). Hence the mercury in the tube stays back. The reading of the thermometer on the stem can be taken without any hurry. After use, the mercury in the tube can be forced through the constriction back to the bulb by flicking the thermometer vigorously. The normal human body temperature is 36.9°C.

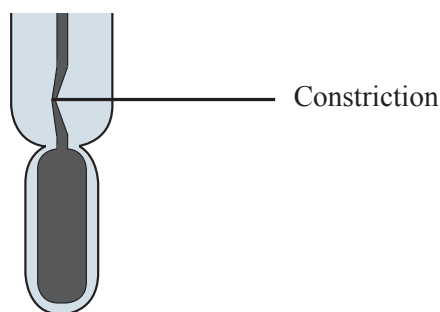

Fig. 4.6: Constriction of a clinical thermometer

## The Six's minimum and maximum thermometer

### Activity 4.9

To demonstrate the working of the six's thermometer

#### Materials

- Reference books
- Internet

#### Steps

1. Conduct research on six's minimum and maximum thermometer.
2. In your research find out:
  - (a) how it is calibrated.
  - (b) the range of scales.
  - (c) the minimum and maximum values on each scale.
  - (d) the liquids used in the six's thermometer.
  - (e) how it works.
3. Compare and discuss your findings with other groups in class.

Six's maximum and minimum thermometer is used to measure the maximum and minimum temperature of a place during a day. It was invented by a physicist called *John Six*. The thermometer consists of a U-shaped tube connected to two bulbs. The U-tube contains mercury. The two bulbs contain alcohol, which occupies the full volume of one of the bulbs. The other bulb has a space above alcohol. There are two indices fitted with light fine springs (Fig. 4.7).

When temperature rises, alcohol occupying the full volume of bulb A, expands and forces mercury in the U-tube to rise on the right hand side. Mercury, in turn, pushes the index  $I_2$  upwards. The maximum temperature can be noted from the lower end of index  $I_2$ .

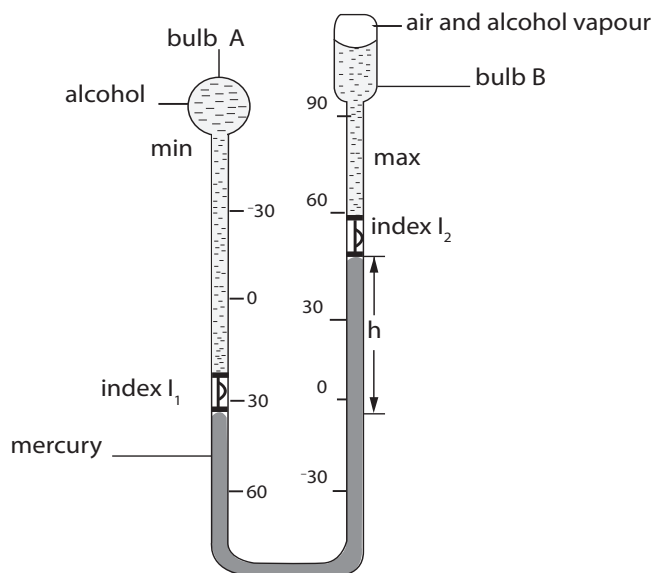

Fig. 4.8: Six's maximum and minimum thermometer

When the temperature falls, alcohol in bulb A contracts. Due to the pressure difference in the two arms of the U-tube, mercury level will rise on the left hand side of the U-tube pushing the index  $I_1$  upwards. The index  $I_2$  on the right hand side is left behind (held by the fine spring) to register the maximum temperature. The lower end of index  $I_1$ , touching the mercury meniscus gives the minimum temperature.

The two steel indices can be reset with the help of a magnet.

## 4.6 Calibration of thermometers

### To calibrate a mercury thermometer

#### Activity 4.10

To demonstrate how to calibrate a mercury thermometer

#### (a) Lower fixed point

#### Materials

- Thermometer
- Ice
- Stand and clamp
- Bunsen burner
- Beaker

#### Steps

1. Immerse the bulb completely inside a beaker containing pure melting ice as shown in Fig. 4.8 (a). Why is it necessary to completely immerse the bulb? What can you note about the reading on the thermometer?

2. Wait for sufficient time for the mercury to attain the temperature of the melting ice (Fig. 4.8 (b)).
3. When there is no more change in the level of mercury, mark its position on the stem. Suggest the name given to the marked position.

The point marked is the lower fixed point. Mark it as  $0^{\circ}\text{C}$ . Note that the melting point of ice is exactly  $0^{\circ}\text{C}$  at standard atmospheric pressure (760 millimetres of mercury).

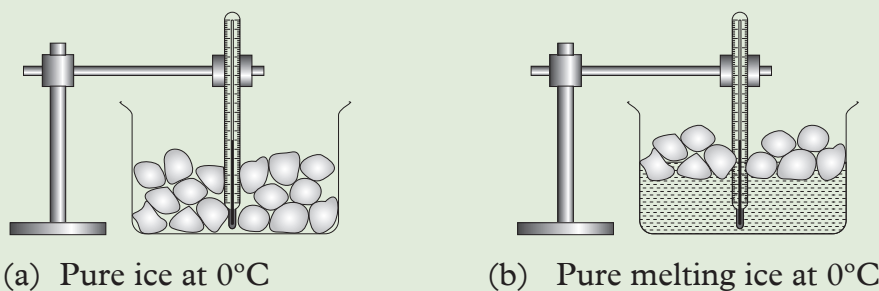

Fig. 4.8: Calibrating the lower fixed point

### (b) Upper fixed point

#### Steps

1. Expose the bulb to steam just above the boiling water as shown in Fig. 4.9.

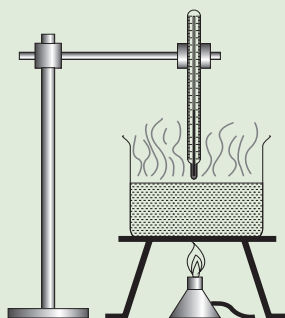

Fig. 4.9: Calibrating the upper fixed point

2. Give it time for the mercury to attain the temperature of the steam.
3. When there is no more change in the level of mercury, mark its position on the stem.

The point marked is the upper fixed point. Mark it as  $100^{\circ}\text{C}$ . The temperature of steam is exactly  $100^{\circ}\text{C}$  at standard atmospheric pressure (760 mmHg).

Thermometers are calibrated by identifying the fixed points. The fixed points will help in determining the highest and the lowest values a thermometer can measure.

A fixed point is a single temperature at which a particular physical event always takes place.

There are two types of fixed points namely: *upper fixed point* and *lower fixed point*.

The upper fixed point (steam point) is the temperature of steam above pure boiling water at normal atmospheric pressure. It takes place at  $100^{\circ}\text{C}$  at sea level.

The lower fixed point (ice point) is the temperature of a pure melting ice at normal atmospheric pressure. It takes place at  $0^{\circ}\text{C}$ . The different between the lower fixed point and upper fixed point is called the **fundamental interval**.

The distance between the two fixed points is divided into 100 equal parts. The scale obtained is called the *centigrade scale*, and the thermometer is known as the *centigrade thermometer*. Each division on the scale is one degree centigrade ( $1^{\circ}\text{C}$ ).

Thermometers may be used to measure unknown temperature as shown below.

The stem of thermometer is  $y$  cm long between the upper and lower fixed points. The mercury thread is  $x$  cm above the lower fixed point at the unknown temperature  $\theta$ .

$$\text{Therefore, } \theta = \frac{x}{y} \times 100^{\circ}\text{C}$$

Where  $\theta$  is the temperature in  $^{\circ}\text{C}$ .

### Example 4.10

Fig. 4.10, not drawn to scale, shows a mercury-in-glass thermometer where the mercury level stands at 1 cm mark in the tube at  $0^{\circ}\text{C}$ .

- (a) Calculate the temperature when the mercury level stands at 7.5 cm mark.
- (b) Find the mercury level in the thermometer when the temperature is  $61^{\circ}\text{C}$

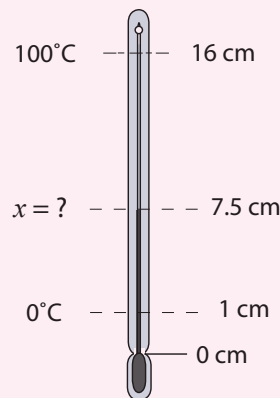

Fig. 4.10: Thermometer

### Solution

(a) The distance between the two fixed points is  $16.0 - 1.0 = 15.0$  cm.

This distance represents a temperature change of  $(100 - 0) = 100^\circ\text{C}$ .

Let  $(7.5 - 1.0)$  cm represent a temperature  $x^\circ\text{C}$

$$\begin{aligned} 15 \text{ cm represents } 100^\circ\text{C} & \qquad \qquad \qquad \text{or} & \qquad \qquad \theta = \frac{x}{y} \times 100^\circ\text{C} \\ 1 \text{ cm represents } \frac{100}{15}^\circ\text{C} & & & & = \frac{6.5}{15} \times 100^\circ\text{C} \\ \therefore 6.5 \text{ cm represents } x = \frac{100}{15} \times 6.5 & & & & = 43.3^\circ\text{C} \\ & & & & = 43.3^\circ\text{C} \end{aligned}$$

$\therefore$  The temperature reading is  $43.3^\circ\text{C}$

(a)  $100^\circ\text{C}$  is represented by 15 cm

$$1^\circ\text{C represents } \frac{15}{100} \text{ cm}$$

$$61^\circ\text{C is represented by } \frac{15 \times 61}{100} \text{ cm} = 4.15$$

$$\text{Level of mercury} = 4.15 \text{ cm} + 1.0 \text{ cm}$$

$$= 5.15 \text{ cm}$$

### Exercise 4.2

1. Describe how a clinical thermometer works.
2. Briefly explain the meaning of:
  - (a) Lower fixed point.
  - (b) Upper fixed point.
3. State two properties of thermometric liquids.
4. A thread of mercury in the bore of a thermometer has a length of 9 cm when the temperature is  $15^\circ\text{C}$ . When the temperature rises to  $101^\circ\text{C}$ , the length increases to 20 cm. Find:
  - (a) The length when the temperature is  $75^\circ\text{C}$ .
  - (b) The temperature when the length is 12 cm.



## 4.7 Effects of temperature change on solids

### Activity 4.11

### To determine the melting point of ice

#### Materials

A 500 g of pure ice, a copper calorimeter, source of electric power

#### Steps

1. Take 500g of pure crushed ice at about  $-10^{\circ}\text{C}$ .
2. Put the ice in a well insulated copper container as shown in Figure 4.11.
3. Record the initial temperature of the ice. Turn on the power supply and start the stopwatch at the same time.

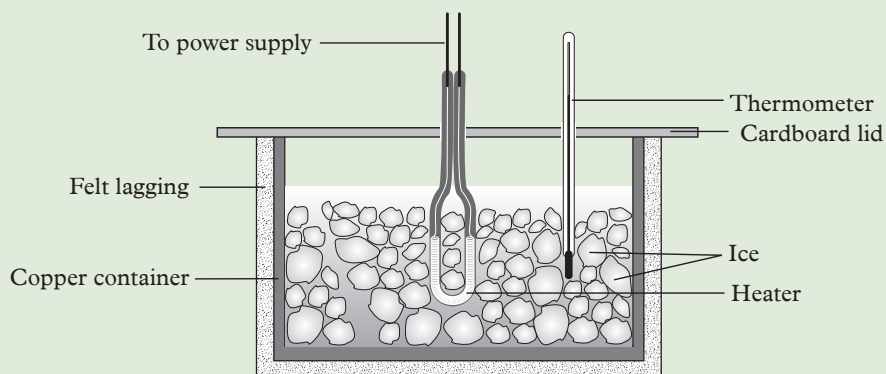

Fig. 4.11: Heating ice – melting process.

4. Record the temperature of ice at 30 seconds intervals until the temperature of the container is about  $10^{\circ}\text{C}$ . Record your result as shown in Table 4.1.

Time(s)	0	30	60	90	120	140	160	180	200
Temp. ( $^{\circ}\text{C}$ )									

Table 4.1: Relationship between temperature and time

What happens to the amount of ice as heating continues?

5. Plot a graph of temperature against time. Explain the shape of the graph.
6. From the graph determine the melting point of ice.

When ice is heated and a graph of temperature against time recorded, a graph like the one shown in Fig. 4.12 is obtained.

Fig. 4.12 shows the graph of temperature against time.

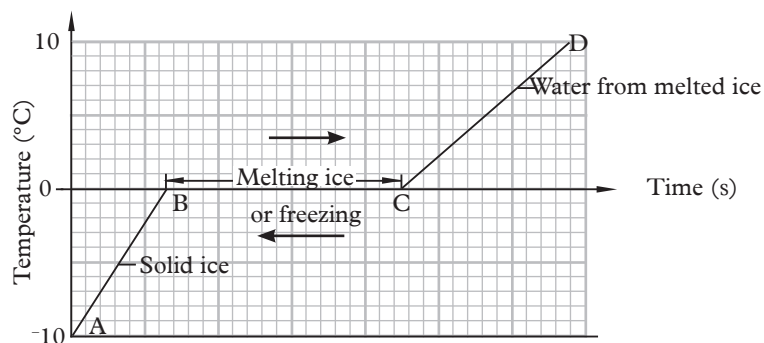

Fig. 4.12: A graph of temperature against time for melting ice

The graph shows that:

1. The temperature of ice rises steadily from  $-10^{\circ}\text{C}$  to  $0^{\circ}\text{C}$ . During this time, along AB, the ice remains as solid.
2. At  $0^{\circ}\text{C}$ , along the line BC, the temperature remains constant for a period of time. During this period, the ice is observed to be melting. At C all the ice has melted and it becomes water. The heat supplied during this time is used to break up intermolecular forces between the ice molecules.
3. After all the ice has melted, the temperature of water starts rising again as seen along the line CD of the graph.
4. From  $0^{\circ}\text{C}$ , the temperature of ice at  $0^{\circ}\text{C}$  starts to drop steadily.

If pressure remains unchanged, a solid substance melts at a specific temperature. Similarly the liquid freezes at the same temperature. This temperature is called the *melting point* or *freezing point* of a substance. The melting point of pure ice is  $0^{\circ}\text{C}$  and the freezing point of pure water is also  $0^{\circ}\text{C}$  under standard atmospheric pressure.

#### 4.7.1 Factors affecting melting point of a substance

##### Pressure

Under standard atmospheric pressure, a pure substance always melts at a definite temperature. The melting point, however, changes with the change in pressure acting upon on a substance. The change in the melting point due to change in pressure is, however not large.

### Activity 4.12

### To show the effect of pressure on the melting point of ice

(Work in groups)

#### Materials

- Two stools or two cement blocks
- Ice block
- Two equal weights
- Wire

#### Steps

1. Rest a large block of ice at 0 °C on two stools or two cement blocks.
2. Hang a thin copper wire around the block and attach two equal heavy weights to the ends of the wire as shown in Fig. 4.13.

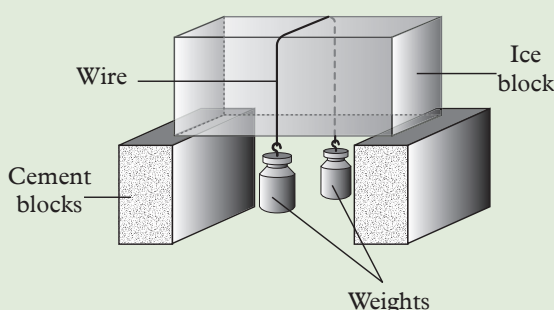

Fig. 4.13: Effect of pressure on melting point of ice

3. Observe and record what happens to the wire and the block of ice
4. What do you think would happen if the weights used were lighter?

The wire completely cuts right through the block of ice and the weights fall to the floor.

In the above experiment it is also observed that initially as the pressure of the wire on the ice increases, the melting point of ice decreases and so the ice melts. The water flows above the wire. The latent heat required for the melting of ice comes from the copper wire.

The water above the wire is no longer under pressure. As the pressure is released, the water which is at a temperature below zero freezes again binding the two pieces of ice together. During freezing, heat is given out by water and this heat is conducted down through the copper wire. This provides heat for further melting of the ice under the wire. At one stage, the wire cuts right through the block of ice and falls to the floor, leaving ice still in a solid block.

This phenomenon where ice melts when pressure is increased and again solidifies (freezes) when the pressure is reduced is called *regelation* (again: gelare, freeze).

Ice contracts on melting. An increase in pressure would help it in its contraction and hence we should expect a decrease in the melting point of ice as pressure on its surface is increased. *The melting point of ice decreases with the increase in pressure.*

For substances like wax, gold, silver etc. which expand on melting, an increase in pressure would make its expansion difficult. These substance have to be heated more in order to melt. As a result, we should expect an increase in the melting point, as pressure is increased. For such substances, *the melting point increases with the increase in pressure.*

### **Impurities**

Experiments show that *impurities decrease the melting point of a substance.* Though pure water freezes at 0 °C, salty water would remain as water even at -1 °C. The extent to which the freezing point is lowered depends upon the concentration of impurities dissolved into the liquid. For example when salt is added to ice, its melting point is reduced to a value as low as -10 °C. This method is used to defreeze roads in cold countries during winter. It is also notable that in the cold countries, it is common to have snow on land while the sea remain unfrozen. Antifreeze material is added to the water in the car radiators to stop water from freezing when temperature falls below 0 °C.

## **4.8 Effect of temperature change in liquids**

### **4.8.1 To determine heating/cooling curves for liquids**

#### **To draw the heating curve for pure water**

#### **Activity 4.13**

#### **To draw the heating curve of pure water**

#### **Materials**

- Round bottom flask
- Tripod stand
- Thermometer
- An L - shaped delivery tube
- Source of heat
- Stop watch
- Pure water

#### **Steps**

1. Take some pure water at room temperature in a glass heating flask and insert a thermometer as shown in the Fig. 4.14.

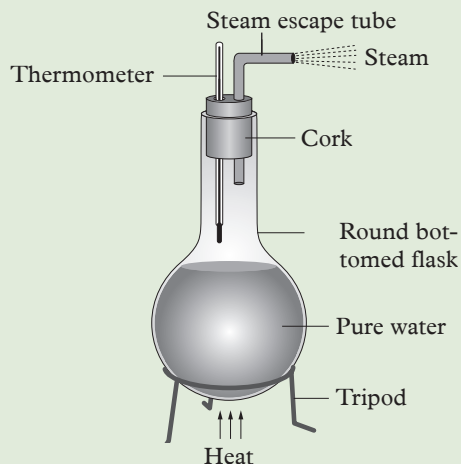

Fig 4.14: Heating pure water

2. Note the initial temperature of the water. What happens to the temperature of water in the initial stages?
3. Heat the water steadily and note the temperature at regular intervals of time. What happens to the volume of water as boiling continues?
4. Continue heating for about 2 to 3 minutes even after the steam is seen to escape from the steam escape tube. What is the temperature when the steam is seen to escape from the escape tube? Suggest the meaning of boiling?
5. Record your result in a tabular form as shown in Table 4.2.

Time(s)	0	30	60	90	120	140	160	180
Temp. ( $^{\circ}\text{C}$ )								

Table 4.2: Relationship between temperature and time

6. Plot a graph of temperature against time. Write down your observation from the graph. Determine the boiling point of water from the graph.

It is important to note that when heat is supplied to water in a heating flask the following are observed:

- The temperature of water rises steadily.
- Then, temperature remains constant for sometime.
- Finally, the temperature rises again.

Boiling is a process in which a liquid is changes to vapour at a constant temperature. Fig. 4.15 shows the graph for the boiling process of water.

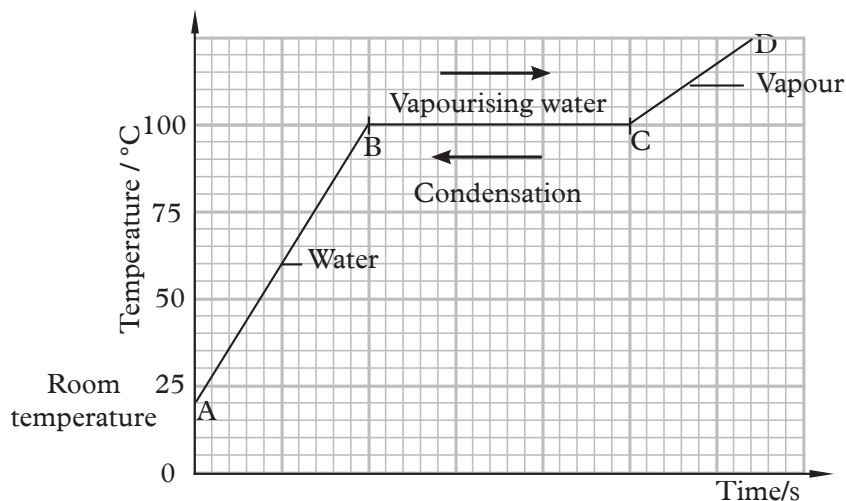

Fig. 4.15: Vaporisation of water

The graph shows that:

1. The temperature of water rises steadily from room temperature. During this time, along AB, water remains as liquid.
2. At 100°C, along the line BC, the temperature remains constant for a period of time. During this period, water is observed to be boiling. At C all the water has turned into water vapour. At this point heat supplied is used to break the intermolecular forces holding the water molecules together.
3. After water has turned into vapour, the temperature of vapour rises again as seen along the line CD of the graph.

If pressure remains unchanged, a liquid substance always boils at a fixed temperature. This temperature is called the *boiling point of the liquid*. The boiling point of pure water is 100 °C under standard atmospheric pressure.

### To determine the boiling point of methylated spirit

#### Activity 4.14

#### To determine the boiling point of methylated spirit

##### Materials

- Column flask
- Thermometer
- Methylated spirit
- Water bath, anti-bumping granules
- Glass rods
- Glass wool
- Bunsen burner

## Safety measures

- Methyl spirit is highly flammable, care must be taken when handling it. Let your teacher guide you in all steps of this activity.
- Ensure that all glassware is securely clamped.

## Steps

1. Set-up the micro-fractional column as shown in Fig. 4.16.

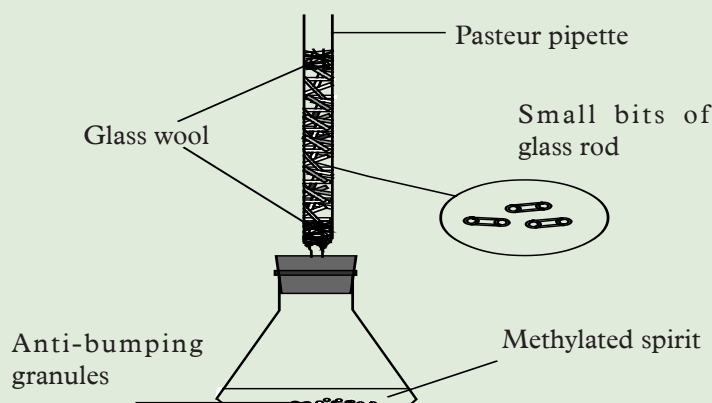

Fig. 4.16: Micro-fractional column

2. Place about  $10\text{ cm}^3$  of the methylated spirit into the small conical flask and add some anti-bumping granules. Why is it necessary to use anti-bumping granules?
3. Place the set-up in a water bath. Why is it heated in a water bath and not directly?
4. Wait for the spirit to boil and allow time for it to attain thermal equilibrium.
5. Using thermometer, determine the boiling point of the liquid collected at the top part of the micro column. What do you get? What is the boiling point of methylated spirit?
6. Compare and discuss your findings with other groups in class.

Water bath is necessary for even distribution of heat. The boiling point of methyl spirit is about  $64.6^\circ\text{C}$ .

## To draw the cooling curve for candle wax

### Activity 4.15

### To draw the cooling curve for candle wax

#### Materials

- Bunsen burner
- wax
- goggles
- stopwatch
- thermometer
- tripod stand

#### Steps

1. Obtain and wear goggles.

#### CAUTION



With the Bunsen burner on and a beaker of boiling water on the ring stand, there is risk of injury.

2. Obtain a test tube with the thermometer frozen into the wax. Lower it into a beaker of cold tap water. (Fig.4.17)

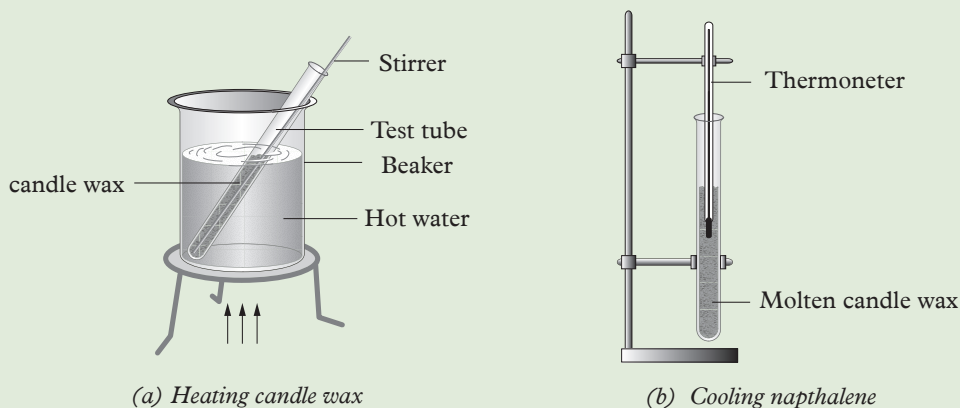

Fig. 4.17: Heating and cooling candle wax

3. Start recording temperature every 30 seconds on the melting data table.
4. Have your teacher come by to light your Bunsen burner (goggles must be on). Make sure the Bunsen burner flame is just touching the wire mesh. You must record temperatures every 30 s.
5. Wait for the wax to melt, and then record temperatures for a full 3 minutes past the point when the wax is completely melted. (Completely melted means clear and transparent).
6. Turn off your Bunsen burner, and call your teacher over to lower the hot water. Clamp everything securely on the ring stand as your teacher shows you.



7. Start collecting data in the freezing table for every 30 s as shown in Table 4.3.

Time (s)	Temp ( $^{\circ}\text{C}$ )
0.00	
0.30	
0.60	
0.90	
0.120	
0.150	
0.180	

Table 4.3: Freezing table

8. Draw a cooling curve of temperature against time.
9. Identify and label on your graph the melting point/freezing point of candle wax.

If a graph of temperature ( $^{\circ}\text{C}$ ) against time  $t$  (s) is drawn, a graph like one shown in Fig. 4.18 is obtained.

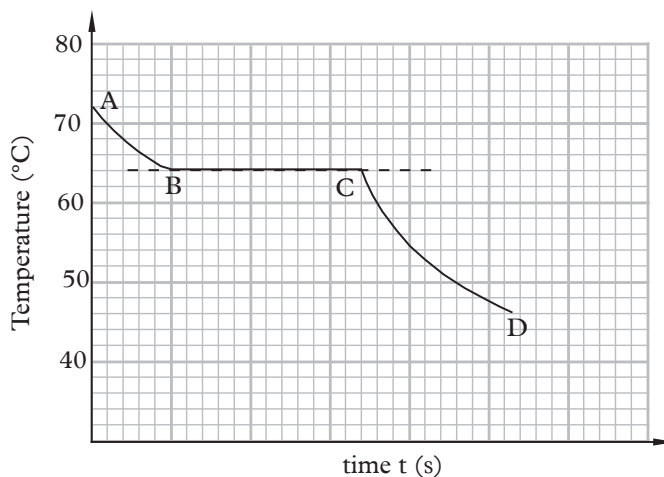

Fig. 4.18: Cooling curve for candle wax

Kinetic theory of matter may be used to explain the cooling curve for candle wax.

1. The curve AB represents the candle wax in liquid state. The temperature falls as the liquid is above the temperature of the surroundings. As a result the molecules lose both their kinetic and potential energies. This results in a decrease in speed of the molecules and they come close together.

- The straight line section of the graph (BC) represents the mixture of candle wax in liquid and solid states. At B it is mainly in the liquid state and at C is mainly in the solid state. As its temperature is still above the temperature of the surroundings, heat is given out, but at a constant temperature. Candle wax melts at  $64^{\circ}\text{C}$
- The curve CD represents candle wax in solid as it continues to cool since its temperature is still above room temperature.

## 4.8.2 Factors affecting boiling point

### Impurities

#### Activity 4.16

To determine the effect of impurities on Boiling point

#### Materials

- Thermometer ( $110^{\circ}\text{C}$ )
- Tripod and gauze mat
- Salt water
- Conical flask
- Clamps –boss head and stand
- Bunsen burner

#### Steps

- Replace the  $100^{\circ}\text{C}$  thermometer with  $110^{\circ}\text{C}$  thermometer and pure water with salt one in Activity 4.13 i.e. to show the heating curve of pure water
- Heat the solution and record the temperature in every 30 seconds after the temperature has reached  $90^{\circ}\text{C}$ .
- Record your observations in a tabular form as shown in table 4.4.

Time (s)	0	30	60	90	120	150	180		
Temp ( $^{\circ}\text{C}$ )									

Table 4.4: Relationship between temperature and time

- Draw a graph of temperature ( $^{\circ}\text{C}$ ) against time (s).
- From your graph, determine the boiling point of salt water. What can you say about the effect of solute on the boiling point of the liquid? Discuss.

The value at which salt water boils is higher than that of pure water i.e. more than 100 °C.

We can therefore conclude that **solute increases the boiling point of liquids.**

## Pressure

### Activity 4.17

#### To show the effect of pressure on boiling point

(Work in groups)

#### Materials

- A thermometer
- A round bottom flask
- A vacuum pump
- A tripod stand

#### Part 1

#### Steps

1. Take some warm water in a glass flask fitted with a two-holed rubber bung.
2. Pass a thermometer through one hole and a short glass tube through the other (Fig. 4.19).

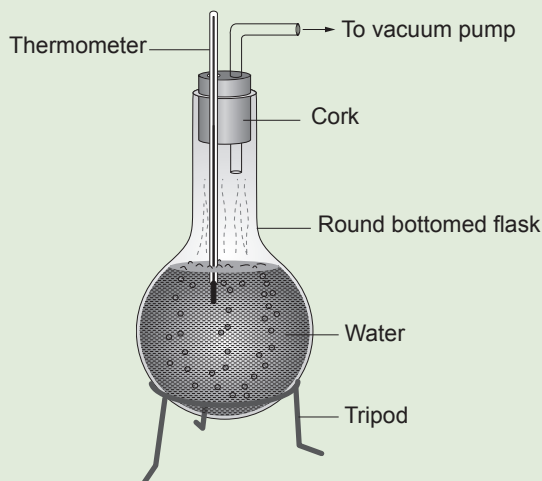

Fig. 4.19: Water boiling under reduced pressure

3. Connect the glass tube to a vacuum pump. Note the initial temperature of the warm water.
4. Start pumping out air from inside the flask. What happens to the water? Observe the thermometer reading as more and more air is pumped out of the flask.

## Part 2

### Steps

- Modify the set up in Activity 4.18 (Fig. 4.20) to be as in (Fig. 4.21) to show the effect of increase of pressure on the boiling point of water.

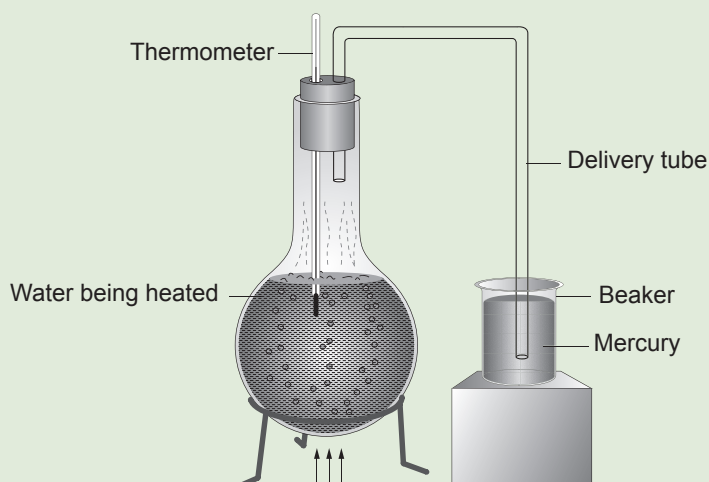

Fig. 4.20: Boiling point is raised with increased in pressure.

When the water in the flask is heated, without the delivery tube, water boils at  $100^{\circ}\text{C}$  under standard atmospheric pressure. When the delivery tube is fitted with its other end dipped in mercury, water vapour cannot escape and the pressure on the water surface in the flask increases. The thermometer shows a rapid rise in temperature showing that the boiling point of water has increased.

This shows that *the boiling point increases with increase in pressure*. Using the same argument, a cooking pot with a lid on cooks faster than one without a lid.

It is common to see cooking pots being covered with lids to quicken the process of cooking food.

The cooking pot with a lid takes less time to boil than the uncovered pot.

The boiling point of the liquid in the pot with lid is slightly higher. A pressure cooker uses this idea.

Boiling point of water increases with increase in pressure.

### Exercise 4.3

With regard to the effect of pressure on boiling point, discuss with your friend the effect of altitude on boiling point of water.

## 4.9 Evaporation

We have seen earlier that boiling is a process in which a liquid is converted to vapour at a fixed temperature. Like boiling, evaporation is a process in which a liquid is converted to vapour but at all temperatures. Evaporation of a liquid occurs from the surface of a liquid. Wet clothes spread outside in the sun become dry. The same wet clothes spread inside the house on a rainy day becomes eventually dry, but takes a longer time. Similarly water in a shallow dish placed in open air gradually diminishes and ultimately disappears altogether. A puddle of water on the roadside always clears up in dry and sunny weather. However the puddle last longer in cold weather, but eventually clears up.

Molecules move freely within a liquid and the energy is mainly kinetic. However there is a small force of attraction between the molecules. The molecules are continually breaking through the surface of the liquid, but most of these are attracted back to the liquid by the cohesive forces. Some escape from the surface of the liquid. The gradual loss of molecules in this way is known as evaporation. Since the fast moving molecules escape, the average kinetic energy of the remaining molecules is reduced. As temperature is a measure of the average kinetic energy of the molecules, the temperature of the liquid falls during evaporation. Thus evaporation causes cooling.

### Activity 4.18

#### To show that evaporation causes cooling

#### Materials

- Wooden block
- A bicycle pump
- Metal container
- Ether

#### CAUTION



Ether fumes are dangerous thus this activity should be carried out in a fume cupboard/fume chambers.

## Steps

1. Pour a drop or two of water over the surface of a wooden block and place upon it a small metal container with some ether in it. Fig. 4.21.

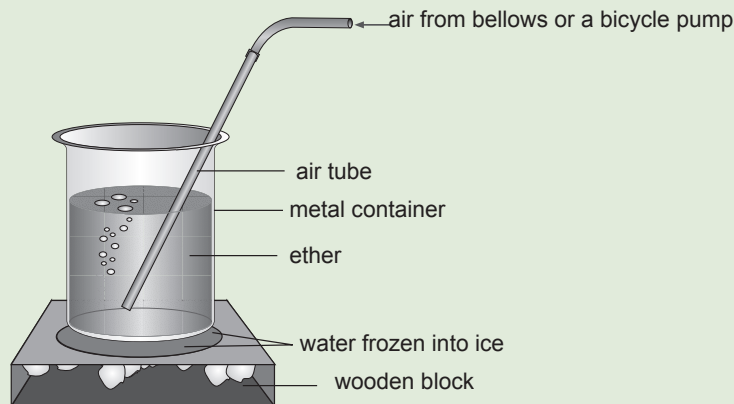

Fig. 4.21: Cooling by evaporation

2. Blow a rapid stream of air through the ether with the help of air bellows or a bicycle pump.
3. After a few minutes, try to lift the beaker off the wooden block. Are you able to lift the beaker with ease? Explain your observation.

The container is stuck to the wooden surface.

The ether evaporates and the vapour is quickly carried away as the bubbles rise to the surface and burst. The rate of evaporation increases.

The sudden change from the liquid to the vapour requires latent heat of vaporisation which comes from the internal energy of the liquid itself. This causes the liquid to cool well below  $0^{\circ}\text{C}$ . At the same time heat is being conducted from the water drops underneath through the metal container and water also cools to  $0^{\circ}\text{C}$ .

The water at  $0^{\circ}\text{C}$ , then, begins to lose latent heat of fusion and finally freezes. Therefore the container is stuck to the wooden block. This experiment proves that evaporation causes cooling i.e. evaporation has a cooling effect

## Factors affecting the rate of evaporation

### Temperature

An increase in temperature increases the rate of evaporation since the molecules gain more kinetic energy which enables them to escape from the surface of the liquid.

### Surface area

Evaporation takes place only at the surface of a liquid. Increasing the surface area of a liquid increases the rate of evaporation. This is why hot tea placed in a flat dish gets colder quickly.

### Pressure

If the pressure acting on the surface of a liquid is decreased, more and more molecules can escape from its surface. Therefore a decrease in pressure increases the rate of evaporation of a liquid. This is why in a vacuum, the evaporation is extremely rapid.

### Draught (air current)

Draught or air currents moving over the surface of a liquid increases the rate of evaporation. This is why wet clothes dry faster on a windy day.

### Nature of liquid

The boiling point of a liquid depends upon the nature of the liquid. Thus, ether having a low boiling point will evaporate more easily than the same quantity of water under similar conditions.

## Similarities and difference between evaporation and boiling

### Similarities

Both evaporation and boiling are processes where a liquid changes its state to vapour. For both processes, the latent heat of vaporisation is required.

### Differences

Evaporation	Boiling
<ul style="list-style-type: none"><li>• Evaporation takes place at all temperatures.</li></ul>	<ul style="list-style-type: none"><li>• Boiling takes place only at a fixed temperature, known as the boiling point of the liquid.</li></ul>
<ul style="list-style-type: none"><li>• Evaporation takes place at the surface of the liquid.</li></ul>	<ul style="list-style-type: none"><li>• Boiling takes place throughout the mass of the liquid.</li></ul>
<ul style="list-style-type: none"><li>• Evaporation uses energy thus has a cooling effect.</li></ul>	<ul style="list-style-type: none"><li>• Once boiling takes place, the temperature of the liquid remains a constant.</li></ul>
<ul style="list-style-type: none"><li>• Evaporation is a slow and a calm process but becomes more rapid at high temperatures.</li></ul>	<ul style="list-style-type: none"><li>• Boiling is a rapid and a noisy process.</li></ul>

**Table 4.6: Differences between evaporation and boiling**

## 4.10 Sublimation and deposition

Sublimation is when a solid is transformed directly into a gas without passing through a liquid state when heated. Deposition is the opposite of sublimation. A gas is transformed into a solid without passing through a liquid state when cooled. Deposition releases energy and is an exothermic phase change. See Fig. 4.22.

## Summary of change of state

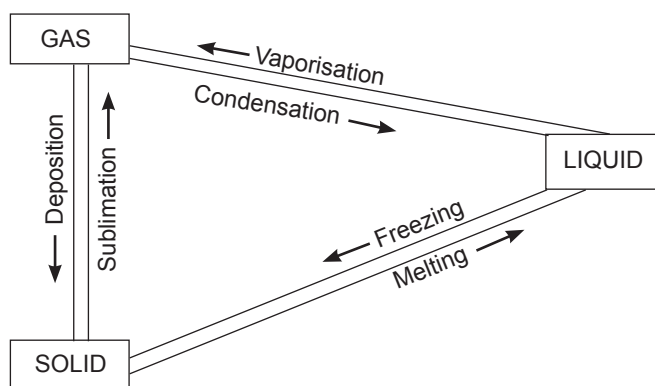

Fig. 4.22: Change of states of matter

### 4.11 Applications of effects of heat on substance

1. Water kept in an earthen pitchers (clay or mud pots) is colder than the one in a metal container. The earthen pot is porous and water seeps through the pores and escapes.

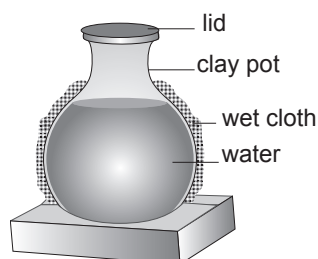

Fig. 4.23: Water in an earthen pot

The required latent heat of vaporisation is being removed from the internal energy of water inside the pot. This causes water inside the pot to cool well below room temperature. If a wet cloth is wrapped around the pot (Fig. 4.23), the rate of evaporation can be speeded up and more cooling effect produced.

2. If a little eau-de-cologne or methylated spirit is sprayed on the hand, the hand feels cold. The spirit has a low boiling point and can change from 'liquid to vapour quite easily at room temperature. Such liquids are called volatile liquids. To change from liquid to vapour, the required latent heat of vaporisation is removed from the hand. The hand loses heat and cool.
3. Human beings sweat (perspire) on a hot day or after a severe exercise. Dogs pant, i.e. hang out their tongue, since their bodies are not porous. The sweating effect or panting is to keep the body cool.



4. When we perspire in hot weather, we prefer to sit below an electric fan. Cooling effect is produced due to rapid evaporation.
5. In hot weather, the sprinkling of roads with water not only lays down the dust particles from the road, but also produces a cooling effect by evaporation.
6. If we expose ourselves to wind with wet clothes on a rainy day, we feel intense cold due to the evaporation of water.
7. The cooling effect caused by evaporation is also applied in the working of a refrigerator, which will be discussed in the following section.

Evaporation is an essential part of the water cycle. Evaporation of water occurs when the surface of the liquid is exposed, allowing molecules to escape and form water vapour, this vapour can then rise up and form clouds. The atmosphere always contains water vapour due to evaporation which goes on continuously from oceans and other water surfaces. The amount of water vapour in air depends on the temperature. If warm air is cooled the excess vapour is converted into water. This process is called *condensation*. This is the process by which rain is caused. By this process, water is moved from the original sources such as lakes, oceans to animals and plants far away from the source.

#### 4.12 The refrigerator

A refrigerator is an appliance for keeping items cold. The operation of a refrigerator depends on two facts:

1. When a liquid evaporates it takes up its latent heat.
2. When a vapour condenses it gives out its latent heat.

Fig. 4.24(a) shows the essential parts of a domestic gas type refrigerator. Figure 4.24 (b) shows a photograph of a commercial refrigerator. The main parts of a refrigerator are: *the compressor, the condenser, evaporator* and *the expansion valve*. The compressor and the condenser are outside the refrigerator while the evaporating coil and expansion valve are inside it. The ‘refrigerant’, i.e. the liquid used in the refrigerator’s circulatory system is freon (dichloro-difluoro-methane) which is non-poisonous and odourless.

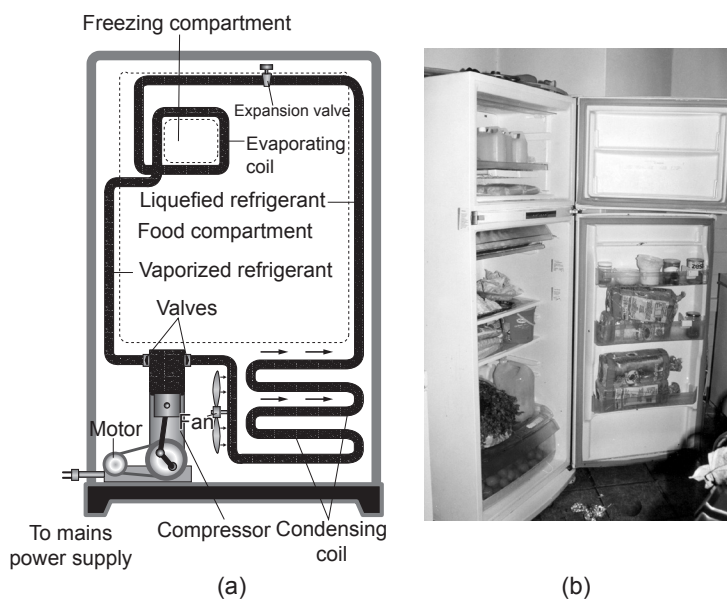

Fig. 4.24: The gas type refrigerator

The refrigerant vapour (gas) is ‘drawn’ in by the compressor. It is then compressed and passed into the condensing coil, which is air cooled by a fan. The gas gets liquified, losing its latent heat of vaporisation. This liquid refrigerant is made to enter the evaporating coil, where the pressure is relatively low. The liquid evaporates at once at a lower pressure and the latent heat of vaporisation required for the change of state is taken from the air in the freezing compartment and other food items stored in it. As a result of this, the temperature of the air in the refrigerator cabinet is lowered to about  $7^{\circ}\text{C}$ , an ideal temperature for storing most of the food items. The temperature quite close to the evaporating coil falls below the temperature of the ice due to large surface area of the coil. The gas goes back into the compressor, gets liquified and the cycle repeats itself.

The refrigerator cabinet is well insulated so that no heat is conducted from outside into it. The temperature inside the cabinet is controlled by a thermostat (a bimetallic strip). When the temperature rises a few degrees above  $7^{\circ}\text{C}$ , the thermostat makes electrical contact and starts the motor. When the temperature inside falls by the desired amount, the circuit is broken by the thermostat and the motor stops working.

### Exercise 4.3

1. Define boiling and melting points of a substance?
2. Describe experiments on how to determine the boiling and melting points of pure water and wax respectively.
3. Explain how solutes affect the boiling point of liquids.

## Topic summary

- Temperature is the degree of hotness or coldness of a body. It is also defined the average kinetic energy of the molecules of a substance.
- The SI unit of temperature is Kelvin (K).
- A thermometer is an instrument used to measure the temperature of a body.
- Liquid-in-glass thermometers commonly use mercury or alcohol as their thermometric substance.
- Clinical thermometer is special type of liquid-in-glass thermometer used to measure the temperature of a human body.
- Lower fixed point is the temperature of pure melting ice at  $0^{\circ}\text{C}$  at standard atmospheric pressure.
- Upper fixed point is the temperature of steam above pure boiling water at  $100^{\circ}\text{C}$  at standard atmospheric pressure.
- Different thermometers use thermometric substances of different properties.
- Absolute zero is the temperature at which gases appears to have zero volume.
- Temperature in Kelvin = (temperature in  $^{\circ}\text{C}$  + 273).

Temperature in  $^{\circ}\text{C}$  = (temperature in K – 273).

- Heat is a form of energy which passes from a body of high temperature to a body of low temperature. The SI unit of heat is joules (J).
- The lower fixed value and upper fixed value of a Fahrenheit scale are  $32^{\circ}\text{C}$  and  $212^{\circ}\text{C}$  respectively.
- To convert Fahrenheit to Celsius, we subtract 32 and then multiply by  $\frac{5}{9}$   
i.e.  $^{\circ}\text{C} = (^{\circ}\text{F} - 32) \times \frac{5}{9}$
- To convert Reaumur to Fahrenheit, we subtract 454.67 i.e.  $^{\circ}\text{F} = ^{\circ}\text{R} - 454.67$ .

## Topic Test 4

1. Define temperature and state its unit.
2. Name four temperature scales and state their fixed points.
3. Explain how one can make a liquid-in-glass thermometer which is sensitive to a small change of temperature.
4. The normal human body temperature is  $37^{\circ}\text{C}$ . What is the temperature in Kelvin?



## Topics in the unit

Topic 5: Reflection of light on plane surfaces

Topic 6: Refraction of light in plane surfaces

## Learning outcomes

### Knowledge and Understanding

- Understand the behaviour of light on plane surfaces.

### Skills

- Research on laws of reflection
- Predict the outcome of a test
- Carry out tests using appropriate measures
- Collect and present results appropriate in writing or drawing
- Interpret results accurately
- Report findings consistent with evidence
- Evaluate the validity of the test

### Attitudes

- Show curiosity in carrying experiments.

### Key inquiry questions

- Why does a plane mirror reverse left and right but not top and bottom?
- How can a virtual image be formed?
- Why an object at a bottom of a glass full of water does appears nearer to the surface of the water?

## Topic Outline >>>

- Different sources of light.
- Rays and beams.
- Classifications of materials as transparent, translucent and opaque.
- Experiments on light propagation.
- Rectilinear propagation of light.
- Types of reflection.
- Formation of shadows and eclipses.
- Lunar and solar eclipses.
- Law of reflection.
- Characteristics of images formed in mirrors.
- Ray diagrams and numbers of images formed in inclined mirrors.
- Pinhole camera, image formation and magnification.

## Introduction

Most of us are familiar with the biblical story of creation. It tells us that the first thing God created was light by uttering “let there be light” and the story says that immediately there was light. On balance the earth receives 12 hours of daylight everyday and its dark for 12 hours each day, although there are considerable variations in different parts of the world and in different seasons. The former is very pleasant to all of us but the latter is not very pleasant. So what is this light that is so precious to us all? Throughout history different theories have been developed on the nature of light. Some great scientists have argued that light is a stream of tiny particles while others have argued that it is a wave. In this unit, we will learn about the nature of light and how it travels.

## 5.1 Nature of light

### Activity 5.1

To find out the meaning of light and its sources

(Work in groups)

Out of your interaction with light, discuss in your group:

1. What light is and how it travels.

2. Sources of light and give examples.
3. Sources that produce their own light and those that depend on the light produced by other sources.

Light is a form of energy. It enables us to see the surrounding objects. Light itself is not visible but its effect is felt by the eye. For example, the track of light entering a room cannot be seen; but the track becomes visible, if some dust particles are present in the room. In a cinema theatre, light from the projector to the screen is visible due to the dust or smoke moving through the path of light.

Light is actually a form of energy in a wave form. It travels at a speed of approximately 300 000 000 m/s or  $3 \times 10^8$  m/s.

## Sources of light

There are two sources of light: luminous and non-luminous sources.

### (a) Luminous sources of light

These are sources (objects) that emit (give out) their own light.

Examples of non-living luminous objects are **sun**, **stars**, **fire**, **candle flame** and **electric bulb**.

Examples of living things that are luminous objects are **fireflies** and **glow worm**.

### (b) Non-luminous sources of light

These are objects that do not emit (give out) their own light. We get to see these objects when they reflect the light falling on them from luminous source onto our eyes.

The **moon** is a good example of a non-living thing that is non-luminous source of light. Others are a **wall** and a **car**. Examples of a living things that are non-luminous sources are **trees** and **animals**.

Fig 5.1 shows how the moon reflects light from the sun to the earth.

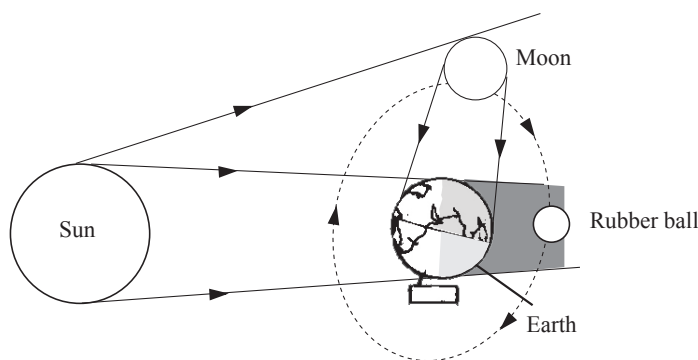

Fig. 5.1: How the moon reflects light to Earth

## 5.2 Rays and beams

### Activity 5.2

To demonstrate the difference between a ray and a beam

(Work in groups)

#### Materials

- A torch
- A small tin open on one side
- Nail
- Hammer
- Dark room

#### Steps

1. Make several small holes at the closed end of the tin using the nail and hammer.
2. Go into a dark room with the container. Switch on the torch and focus its light inside the tin. How does the light come out from the small holes? What does your observation show how light travels?
3. With the help of this activity, discuss with your members what rays and beams are? Suggest types of beams of light.
4. What do you think would happen to the light if there was only one small hole made? Explain.

When a stream of light from a torch is focused into a container that has holes at its end, the beam of light is split into rays to pass through different holes of the container. But what is a ray? *A ray of light is the path along which light travels in a medium.* In diagram, a ray of light is represented with a straight line and an arrow pointing from the source to the destination of light as shown in Fig 5.2



Fig 5.2 : Ray of light

A **beam** of light is a collection or group of light rays. There are three types of beam of light rays:

- (a) **Parallel beam**: consists of rays that are parallel to one another (Fig. 5.3).

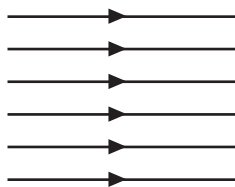

Fig. 5.3: Parallel beam



- (b) **Convergent beam:** consists of rays of light that meet at a point i.e converge (Fig. 5.4).

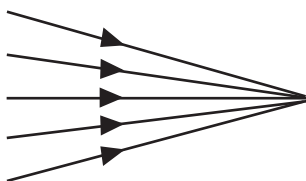

Fig. 5.4: Convergent beam

- (c) **Divergent beam:** consists of rays of light originating from a point source and diverge (spread) to different directions (Fig 5.5)

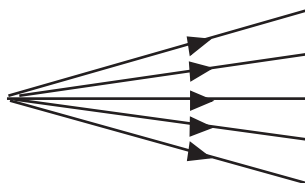

Fig. 5.5: Divergent beam

## Transparent, translucent and opaque materials

To find out what transparent, translucent and opaque materials are

### Activity 5.3

To differentiate between transparent, translucent and opaque objects

#### Materials

- Reference books
- Internet
- Oil
- Piece of paper
- Glass window pane
- A cardboard

#### Steps

1. Look through the glass window pane of your classroom or any of your school building. Do you see through it?
2. Smear some cooking oil or fat on a piece of paper. Look through the oiled piece of paper and the cardboard in turn. Do you see through each of them? What are such materials called.
3. What do you think would happen if the glass was painted black?
4. Conduct research from books and the internet on what transparent, translucent and opaque materials are.
5. In your research, identify examples of each.
6. Present your findings to the whole class through your group leader or any other member of the group.

From activity 5.2 should have identified three types of materials with regard to their ability to allow light to pass through them

**Transparent materials** – These are materials that allow all the light falling on them to pass through them freely. Therefore, we are able to see clearly through these materials.

Examples of transparent materials are air, water and clear glass.

**Translucent materials** – These are materials that allow some light falling on them to pass through. The light get scattered as it passes through. Therefore, objects on the other side of such materials appear blurred and cannot be seen clearly.

Examples of translucent materials are frosted glass, oiled paper, wax paper, ice, tinted windows and some plastics.

**Opaque materials** – These are materials that do not allow light to pass through. When light strikes an opaque object, none of it passes through. Therefore, we cannot see through such materials. When light falls on these materials, much of it is reflected away by the objects while some of it is absorbed and converted to heat energy.

Examples of opaque materials are rocks, wood, soil, metals and exercise book.

### 5.3 Rectilinear propagation of light

#### Activity 5.4

#### To verify rectilinear propagation of light

##### Materials

- Soft board
- A plane mirror
- Plasticine
- White sheet of paper
- A huge object

##### Steps

1. Stand at a distance in front of a huge object.
2. Hold your finger close to and in front of one of your eyes.
3. Close the other eye and try to look at the object. Can you see the object? Suggest a reason for your observation.
4. Now take three cardboards P, Q and R of equal sizes mounted on wooden stands (Fig. 5.6).
5. Make small holes on the cardboards at the same height and also at equal distances from the edges on each cardboards.
6. Place the cardboards on a flat surface (bench) and pass a thread through the holes to ensure they lie on a straight line.
7. Remove the string without disturbing the setup of the three cardboards.

8. Place a lit candle in front of the hole in cardboard P and view from the the hole in R as shown in Fig. 5.6. What do you see? Explain.

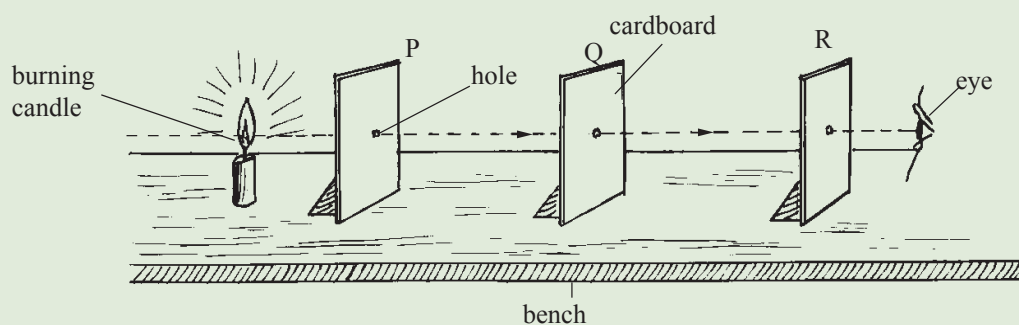

Fig. 5.6: Investigating how light travels

9. Disorganise the arrangement by moving cardboard Q slightly to one side. Try viewing the candle from the hole in cardboard R. Record your observation.
10. What conclusion can you make about the alignment of the three holes and the manner in which the light travels?

The observations in Activity 5.5 suggests that light travels in a straight line. Scientists use the word "*rectilinear*" instead of the phrase "in straight lines" and "propagated" in place of "travel". Instead of stating that *light travels in a straight line*, we can say that *light has the property of rectilinear propagation*.

## 5.4 Formation of shadows and eclipses

### Shadows

#### Activity 5.5

#### To demonstrate how shadows are formed

(Work in groups)

#### Materials

- A white screen
- A candle
- A tennis ball
- 2 cardboard with a large and narrow opening

#### Steps

1. You must have seen a shadow of yourself or any other object when standing in the sun. Based on that experience suggest to your partner the possible answers to the following questions:

- (a) What is a shadow?
  - (b) How is a shadow formed?
  - (c) Share your thoughts with the rest of your classmate in a class discussion.
2. Now, place a burning candle in front a narrow opening cardboard and the white screen behind the cardboard. Place the tennis ball between the cardboard and screen and observe the shadow cast on the screen. Sketch it.
  3. Repeat step 2 using a cardboard that has a wide hole. How different is it from shadow formed in step 2.
  4. Identify the total and partial darkness from your drawing. Suggest appropriate names for them.
  5. Discuss your findings with other pairs in your class.
  6. Draw and label the diagrams on how the shadows were formed on the chalkboard and have a whole class discussion.

A shadow is a partial or total darkness cast by an object blocking the direct rays of light.

### Formation of shadows with a point source of light

A narrow opening through a cardboard forms a **point source of light**, when illuminated with light. An opaque object PQ, placed between opening L and a white screen, obstructs rays of light (Fig. 5.7).

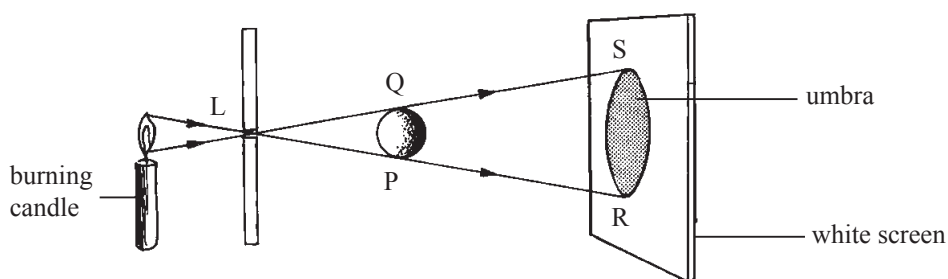

Fig. 5.7: Shadow formation using a point source of light

The area between the lines PR and QS receives no light at all. A shadow of PQ is cast on the screen. The area between R and S is in complete darkness. The region of complete darkness is called **umbra** (latin term meaning shadow).

## Formation of shadows with an extended source of light

A large opening through cardboard forms an **extended source of light** when illuminated with light. An opaque object PQ placed between EL and a white screen obstructs light rays (Fig. 5.8).

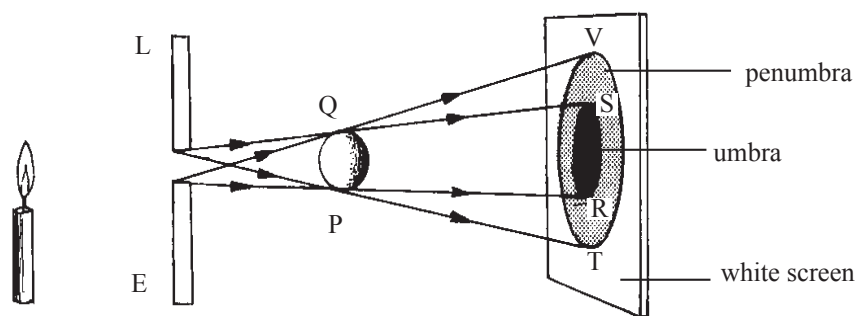

Fig. 5.8: An extended source of light

The region RS on the screen is in complete darkness. The region RT and SV are in partial darkness because light comes from only one part of the extended source. This region of partial darkness is called **penumbra** (latin term meaning almost shadow).

## Eclipses

### Activity 5.6

To find out how different types of eclipses are formed

(Work in pairs)

#### Materials

- Reference books
- Internet
- Earth globe
- Rubber ball
- Source of light (torch)

#### Steps

1. At least once in your lifetime you may have experienced an eclipse (partial darkness) during day time. Tell your partner your experience and what you think or understand causes that to happen after some years.
2. Now, conduct research from books and the internet on eclipses.
3. In your research, find out the types of eclipses and suggest a reason why the sun looks like a very bright ring during the occurrence of one of the eclipses.

4. Using a source of light (torch) a ball or earth globe and a tennis ball, design an experiment to illustrate the different eclipses you have discussed.
5. Draw on the chalkboard the formation each type of eclipse and label it.

An important example of the formation of shadows is the occurrence of **eclipses**. The term eclipse means that light is blocked or cut off from region of observation. Let us discuss two types of eclipses namely solar and lunar eclipses.

### (a) Solar eclipse

When the moon, revolving around the earth, comes in between the sun and the earth, the shadow of the moon is formed on the earth. This is called the **solar eclipse** or the **eclipse of the sun**. Depending on the position of the moon, some parts of the earth lie in the region of umbra and some in the region of penumbra. Total eclipse occurs in the regions of umbra and partial eclipse in the regions of penumbra (Fig. 5.9).

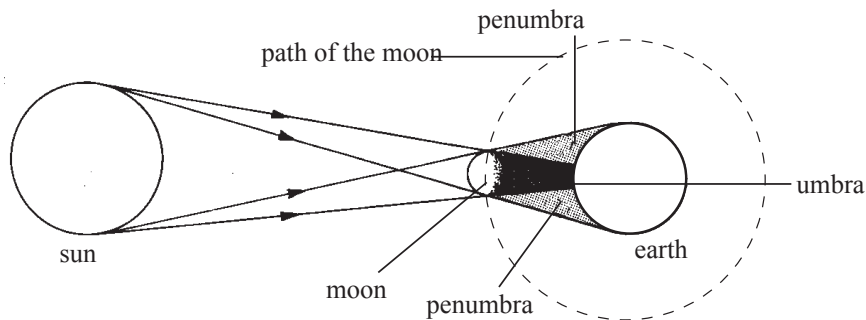

Fig. 5.9: The solar eclipse

### (b) Lunar eclipse

The moon is a non-luminous object. It can only be seen when light from the sun falls on it. When we look at the moon, we see only the shape of the lighted portion. When the earth comes in between the sun and the moon, lunar eclipse (eclipse of the moon) occurs. Depending on the position of the moon, a total eclipse or partial eclipse of the moon will occur. Total eclipse will occur if the moon is in the region of umbra. Partial eclipse will occur if any part of the moon is in the region of penumbra (Fig. 5.10).

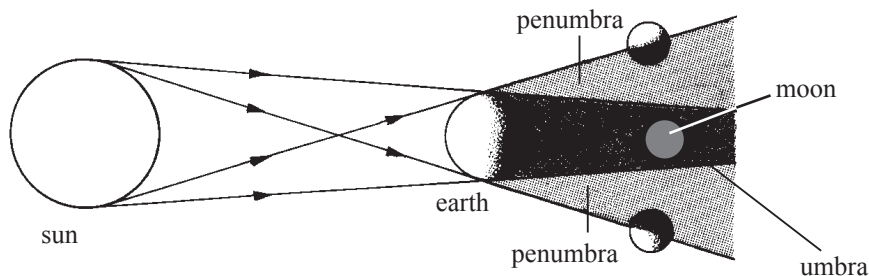
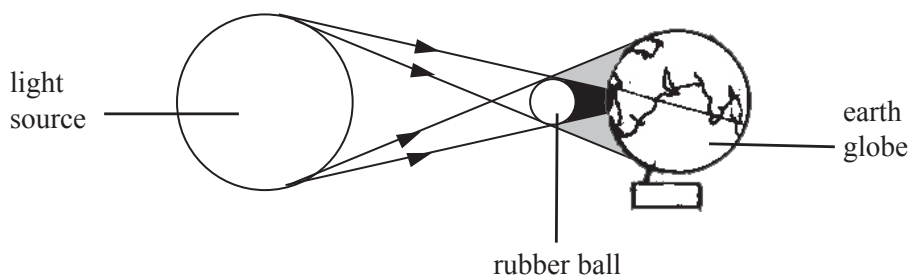

Fig. 5.10: The lunar eclipse

## Demonstration to show solar and lunar eclipses

In Fig. 5.11(a) and (b) shows setups to demonstrate solar and lunar eclipses formation respectively. In both setups, the source of light represents the sun and the rubber ball represents the moon revolving around the earth (globe).



(a) Solar eclipse

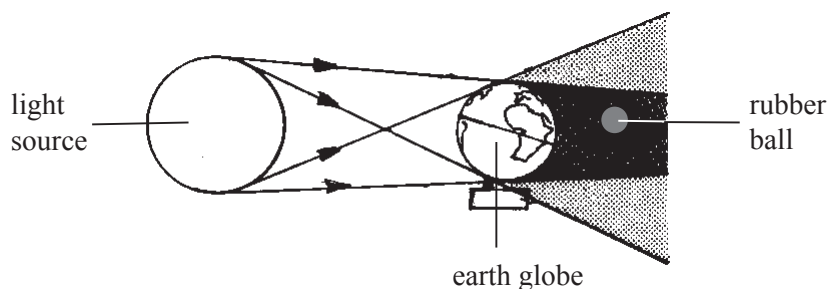

(b) Lunar eclipse

Fig. 5.11: Demonstration of solar and lunar eclipses formation

### Exercise 5.1

1. What is light?
2. (a) What do scientists mean by the phrase rectilinear propagation of light?  
(b) Suggest a simple experiment to illustrate this property of light.
3. Explain the meaning of the following terms:  
(a) A non-luminous object.                      (b) An opaque object.  
(c) A ray and a beam of light.                (d) A shadow.
4. With a simple well labelled diagram, distinguish between the terms umbra and penumbra.
5. Describe with well labelled diagrams the formation of (a) the total solar eclipse and (b) annular eclipse.





5. Explain what will happen to the images formed by the pinhole camera if its pinhole is enlarged.
6. Repeat the activity in pairs until every group member gets the opportunity to view the image of at least one group member with the pinhole camera.  
**Note:** The group member with visual challenges (if any) should stand at a distance and the ones without such challenges view his/her image. Not the other way round.
7. Discuss in the group on the characteristics of the image formed by the pinhole camera, guided by the following questions:
  - (a) Is the image inverted or erect?
  - (b) Is the image virtual or real?
  - (c) How does the image size compare with that of the object?

A pinhole camera consists of a box with a pinhole on one side and a translucent screen on the opposite side. Light rays from an object, pass through the pinhole and form an image on the screen (Fig. 5.13).

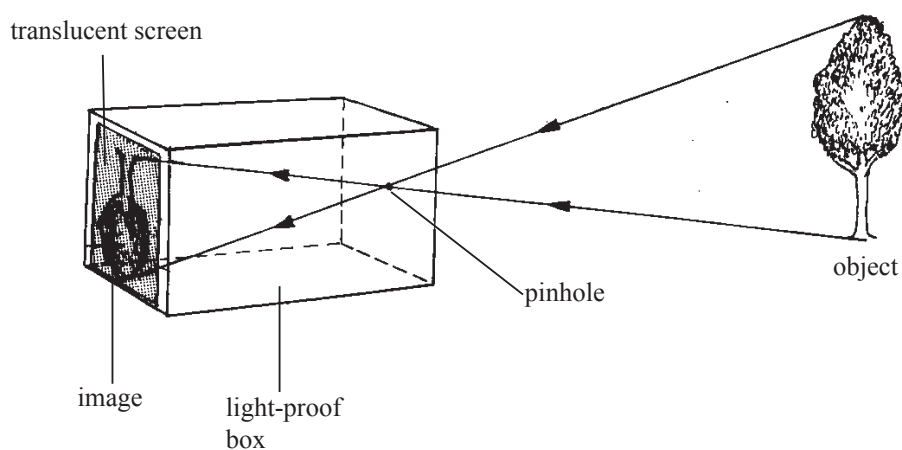

Fig. 5.13: Image formed on a pinhole camera

A pinhole camera has a large depth of field or a large depth of focus.

This means that objects, both far and near from the camera form focused images on the screen. A lens camera has a limited depth of focus as seen in the photograph in Fig. 5.14. Whereas the frog is in focus, the other details in the background are out of focus.



Fig. 5.14: A picture taken with a lens with limited depth of focus.

If the pinhole is made larger, the image becomes blurred (out of focus), bigger and brighter due to overlapping of many rays (Fig. 5.15). A large pinhole of a pinhole camera is like having several pinholes put together. The overlapping images form a bigger but blurred image. A large hole allows more light hence a brighter image.

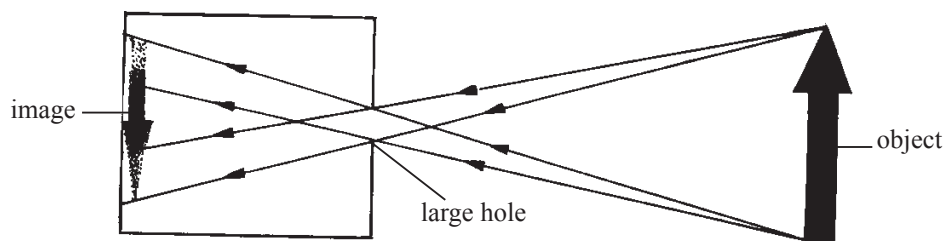

Fig. 5.15: Formation of blurred image due to a large pinhole

### Characteristics of the image formed by a pinhole camera

1. The image formed is **real**. A real image is an image that can be formed on a screen. An image that cannot be formed on a screen is called a **virtual image**.
2. The image is inverted i.e upside down.
3. The image is smaller than the object.

### Magnification produced by a pinhole camera

The term magnification refers to how big or small the image is compared to the object. Magnification is defined as the *ratio of the height of the image to the height of the object*.

$$\text{Magnification (m)} = \frac{\text{height of the image (IM)}}{\text{height of the object (OB)}}$$

$$m = \frac{IM}{OB}$$

Sometimes it becomes difficult to measure the height of the image or the height of the object accurately. In such cases, magnification can be calculated in terms of object and image distances. For example, consider a pinhole camera far from a tree and another one near a tree (Fig. 5.16).

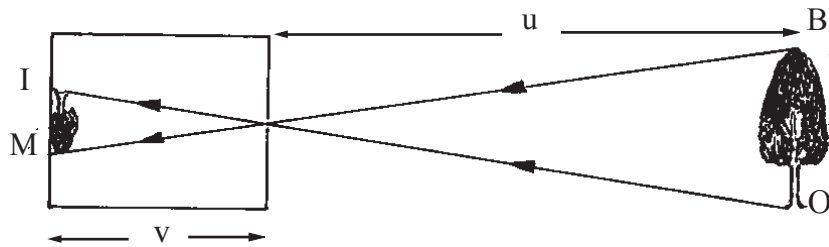

(a) Pinhole camera far from a tree

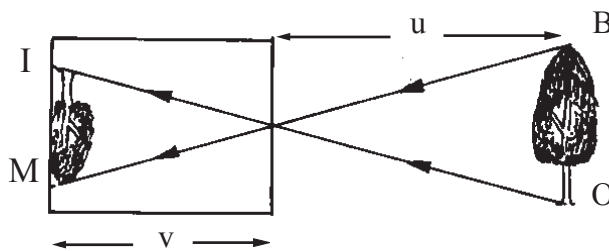

(b) Pinhole camera near a tree

Fig. 5.16: Image formed on a pinhole camera

The height of the image in Fig. 5.16(a) is smaller compared to the height of the image in Fig. 5.16(b). This is because the distance of the tree from the camera in (a) is more than the distance from the camera in (b). When the object distance is decreased, magnification increases.

Using the symbols, **u**, for the object distance (distance between the object and the pinhole) and, **v**, for the image distance (distance between the image and the pinhole), **magnification** is defined as *the ratio of the distance of the image from the pinhole to the distance of the object from the pinhole* i.e

$$\text{Magnification (m)} = \frac{\text{distance of the image from the pinhole (v)}}{\text{distance of the object from the pinhole (u)}}$$

$$m = \frac{v}{u}$$

Combining the two equations, we can write the formula for magnification as

$$m = \frac{IM}{OB} = \frac{v}{u}$$

### Example 5.1

A pinhole camera of length 20 cm is used to view the image of a tree of height 12 m which is 40 m away from the pinhole. Calculate the height of the image of the tree obtained on the screen.

#### Solution

$$\text{Magnification, } m = \frac{\text{height of the image}}{\text{height of the object}} = \frac{\text{image distance}}{\text{object distance}}$$

$$\therefore m = \frac{IM}{OB} = \frac{0.20 \text{ m}}{40 \text{ m}}$$

$$\therefore \frac{IM}{12 \text{ m}} = \frac{0.20 \text{ m}}{40 \text{ m}}$$

$$IM = 12 \text{ m} \times \frac{0.20 \text{ m}}{40 \text{ m}} = 0.06 \text{ m} = 6 \text{ cm}$$

$\therefore$  The height of the image of the tree is 6 cm.

### Example 5.2

If the pinhole camera, in Example 5.1 is moved by 10 m towards the tree, what will be the height of the tree on the screen?

#### Solution

Now the object distance has decreased by 10 m. Therefore the new object distance,  $u = 30 \text{ m}$

$$\text{Magnification } m = \frac{IM}{OB} = \frac{v}{u}$$

$$\therefore \frac{IM}{12 \text{ m}} = \frac{0.20 \text{ m}}{30 \text{ m}}$$

$$IM = 12 \text{ m} \times \frac{0.20 \text{ m}}{30 \text{ m}}$$

$$IM = 0.08 \text{ m} = 8 \text{ cm}$$

$\therefore$  The height of the image is 8 cm.

## Exercise 5.2

1. What is a pinhole camera?
2. Explain with a well labelled diagram how a simple pinhole camera works. Describe the nature of the image formed.
3. The distance of the object from the pinhole is increased. Discuss how this change affects the brightness, sharpness and the size of the image formed.
4. State and explain the effect on the image formed in a pinhole camera if:
  - (a) the hole is made larger.
  - (b) the length of the box is increased.
5. A pinhole camera is used to take the photograph of a person who is 4 m away from the pinhole. If the length of the box used is 18 cm and the height of the image of the person is 9 cm, calculate the:
  - (a) magnification produced by the pinhole camera.
  - (b) height of the person.
6. A tree 18 m high is observed with a pinhole camera that is placed 40 m away. If the camera is 20 cm long, find the height of the image formed.
7. The length of a pinhole camera is 10 cm. It forms an image of linear magnification of 0.2. Find the position of the object.
8. State three characteristics of the image formed by a pinhole camera.

## 5.6 Reflection of light on plane surfaces

### Activity 5.8

To demonstrate reflection of light at plane mirror

(Work in pairs)

#### Materials

- Plane mirror
- A shiny object

#### Steps

1. Let your partner hold a plane mirror facing the sun. Stand in front of the mirror and look at it from a distance. What do you observe? Explain.
2. Now, look towards a shiny object e.g new iron sheet (Note that it is not advisable to stare at the reflection for long as it may damage your eyes.), a glass window, a car windscreen or a large water body. What do you see? Explain.
3. Use your experience in steps 1 and 2 to describe what reflection of light is.

Your eyes must have at one time been overwhelmed by the bright sunlight reflected by a mirror, very new iron sheets on a roof, a glass window or a car windscreen.

Reflection is the *bouncing off of light as it strikes a surface*. The ray coming from the source is called **incident ray**. The ray moving away from the reflecting surface is called **reflected ray**. (Fig. 5.17)

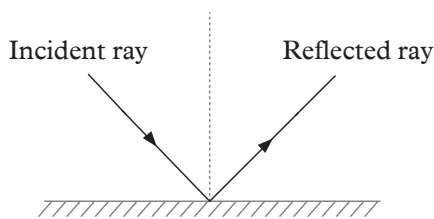

Fig 5.17: A reflection of light

## Types of reflections

### Activity 5.9

#### To differentiate between types of reflection

(Work in groups)

#### Materials

- Mirror and a paper

#### Steps

1. Look through the mirror, what do you observe? Do you see your image?
2. Look through the paper, what do you observe? Do you see your image?
3. What do you think is the difference between the paper and the mirror?

When you put a mirror in front of you, your image is seen. This is because the mirror is smooth hence regular reflection takes place. The same is not observed when a paper is used because rays of light are scattered by the paper because it is rough.

There are two types of reflection; **regular** and **diffuse (irregular)** reflections.

When light is reflected by a plane or a smooth surface, the reflection is **regular** i.e parallel incident rays are reflected parallel to each other. When reflection occurs at a rough surface, it is called **diffuse reflection** i.e incident parallel rays are reflected in random directions. Fig 5.18 shows the two types of reflections.

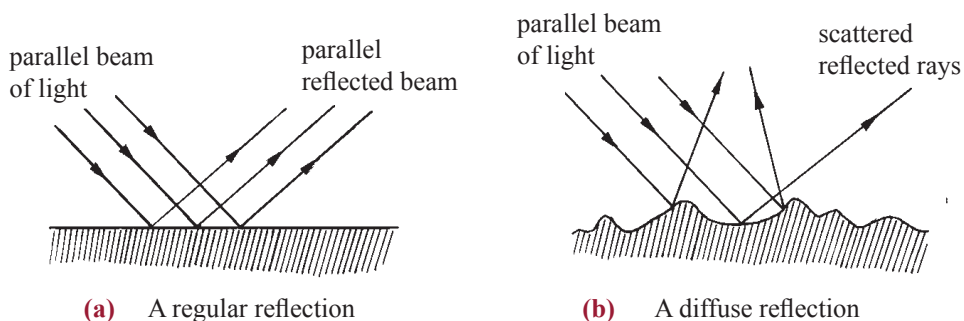

Fig. 5.18 : Reflection of light on different surfaces

## Terms used to describe reflection of light on plane mirrors

### Activity 5.10

### To observe and describe rays on a plane mirror

(Work in groups)

#### Materials

- Plane mirror
- Cardboard
- Ray box

#### Steps

1. Take a plane mirror provided to you, and observe its parts.
2. Now, place the plane mirror vertically on a cardboard and illuminate the shiny surface with a ray box. What do you observe? Explain your observation?
3. Sketch the diagram and identify; angle of incident, the normal, reflected ray and angle of reflection.
4. What do you think would happen if the plane mirror was used to illuminate the shiny surface at different angles?
5. Discuss your findings with others in class.

A thin glass plate coated with silver on one side and a protective layer on the other side is called a **plane mirror** (Fig. 5.19).

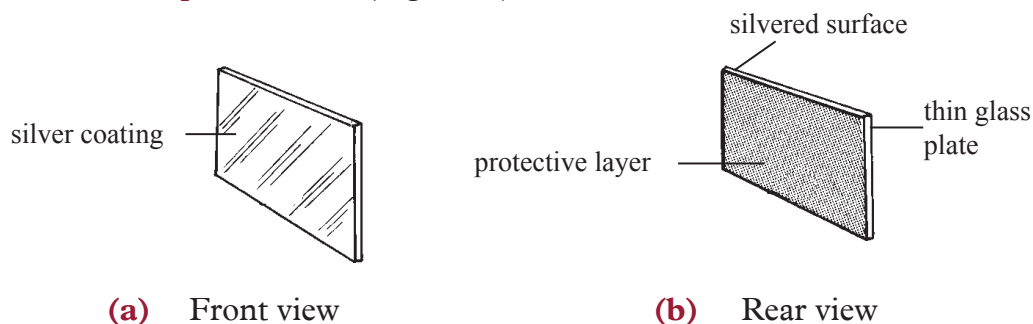

Fig. 5.19: A plane mirror

Fig. 5.20 shows a ray of light AB striking the plane mirror at B and bouncing off to C. The ray AB is called **incident ray** and the ray BC is called **reflected ray**. A line drawn perpendicular to the surface of the mirror at the point where the incident ray and the reflected ray meet is called the **normal (BN)**. The angle between the incident ray and the normal ( $\angle ABN$ ) is called the **angle of incidence ( $\angle i$ )**. The angle between the reflected ray and the normal ( $\angle CBN$ ) is called the **angle of reflection ( $\angle r$ )**.

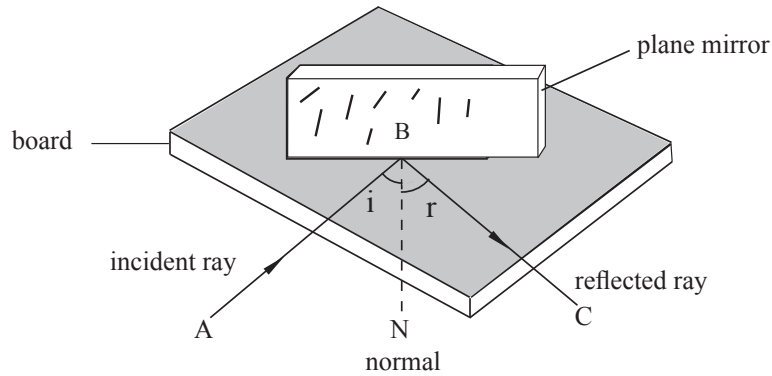

Fig. 5.20: Reflection on a mirror

## To verify the laws of reflection using optical pins

### Activity 5.11

### To verify the laws of reflection using optical pins

#### Materials

- A soft board
- A plane mirror
- Plasticine
- Protractor
- White sheet of paper
- Drawing pin
- 4 optical pins
- A ray box

#### Steps

1. Draw a line PM on a white sheet of paper. Fix the white sheet on a soft-board with drawing pins.
2. Using some plasticine, set up a plane mirror vertically with its plane perpendicular to the plane of the paper and the silvered surface on the line PM (Fig. 5.21(a)).
3. Stick two optical pins  $O_1$  and  $O_2$ , called the object pins, vertically into the softboard, about 6 or 7 cm apart.
4. Keeping the eye along the plane of the paper and in a convenient position, look into the mirror. The images of the two pins are seen. These images appear to be at the rear of the mirror (Fig. 5.21(a)).
5. Move your head to and fro slowly until in one particular position, the images of the two pins lie in a straight line.
6. Fix a third pin,  $I_1$ , called the image pin, such that this pin and the images of the first two pins lie along the same straight line.



7. Repeat the procedure with the fourth pin  $I_2$ , so that the image pins  $I_1$  and  $I_2$  and the images of  $O_1$  and  $O_2$  lie along the same straight line.
8. Using a sharp pencil, mark the positions of the four pins with a small circle and remove the pins and the mirror.
9. Join the points  $O_2$  and  $O_1$  to meet the line  $PM$ . Similarly join the points  $I_2$  and  $I_1$  to meet the line  $PM$ . These lines meet at a point  $B$  on the line  $PM$ .
10. At  $B$ , draw a line  $BN$  perpendicular to  $PM$ . Measure the angle of incidence ( $\angle i$ ) and the angle of reflection ( $\angle r$ ) (Fig. 5.21(b)).

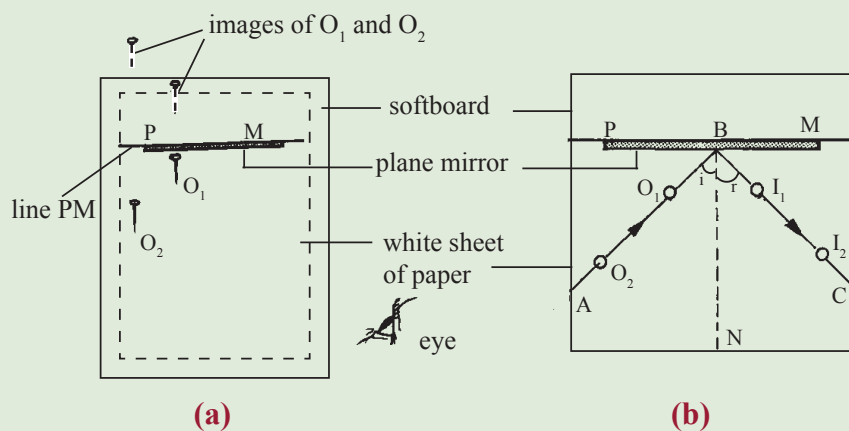

Fig. 5.21: Laws of reflection of light using optical pins

11. Repeat the experiment for three different angles of incidence and record the four readings in a table as shown in Table 5.1. What is the relationship between these two angles?

Angle of incidence, $i$ ( $^\circ$ )	Angle of reflection, $r$ ( $^\circ$ )

Table 5.1: Angle of incidence and reflection

12. Design an experiment to verify the laws of reflection using a ray box instead of pins. If a ray box is available you may be able to carry out the experiment.

### To verify the laws of reflection using a ray box

Light is reflected as a thin beam as shown in fig. 5.22.

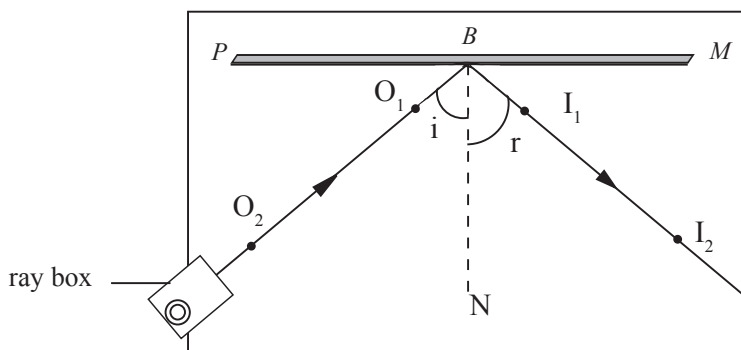

Fig. 5.22: Laws of reflection of light using a ray box

The angle  $i$  is equal to angle  $r$ ,  $O_2 O_1$  joined to the mirror meets lines  $I_1 I_2$  at B. Line NB represents the normal ray to the mirror at B.

The observations also show that the incident ray, the reflected ray and the normal, all lie in the plane of the paper.

The observations are in Activity 5.11 summed up into laws of reflection as follows.

### Laws of reflection

The laws of reflection of light state that:

1. The incident ray, the reflected ray and the normal, at the point of incidence all lie in the same plane.
2. The angle of incidence is equal to the angle of reflection.

## 5.7 Image formation by a plane mirror

### Activity 5.12

To observe the characteristics of images formed by a plane mirror

(Work in pairs)

#### Material

- Plane mirror (Big size)

#### Steps

1. Stand in front of a plane mirror from its reflecting surface. What do you observe? Discuss.
2. List the characteristics of your image formed by the mirror, guided by the

following questions:

- (a) How does your distance from the mirror compare to that of your image from the mirror?
  - (b) How does your size compare to that of your image?
  - (c) Swing your right hand. Which hand does your image appear to swing? Repeat with your left hand.
  - (d) Can you put a screen behind the mirror for your image to be formed there?
  - (e) Is your image upright or upside down?
3. Now place different objects in front of the plane mirror and analyse their images guided by the questions in step 2.
  4. Sketch a diagram to show image formation by a plane mirror.
  5. Discuss your findings with your colleagues in class and deduce the general characteristics of images formed by a plane mirror.

### Image formation for a point object

We need a minimum of two incident rays from a point object to the mirror in order to locate the position of the image using a plane mirror. The reflected rays from the plane mirror, when produced backwards appear to meet at a point. This is the position of the image. The image is **virtual** as it only appears to be there and it cannot be projected on a screen (Fig. 5.23).

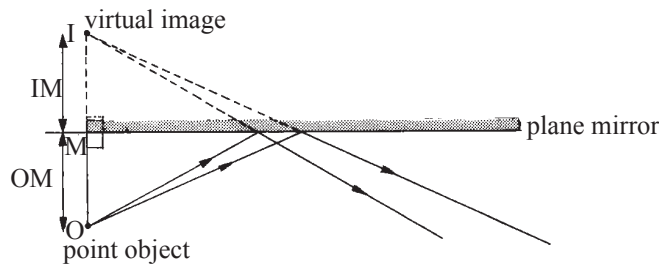

Fig. 5.23: Image of a point object

Measure the perpendicular distance (OM) from the point object O to the mirror and the perpendicular distance (IM) from the position of the virtual image I to the mirror. *The image distance from the mirror is equal to the object distance from the mirror,  $OM = IM$*

### Image formation for an extended object

Place an extended object in front of a vertical plane mirror and observe the image formed (Fig. 5.24). Is the image upright or inverted? What is the size of the image?

The image is erect and the size of the image is the same as the size of the object.

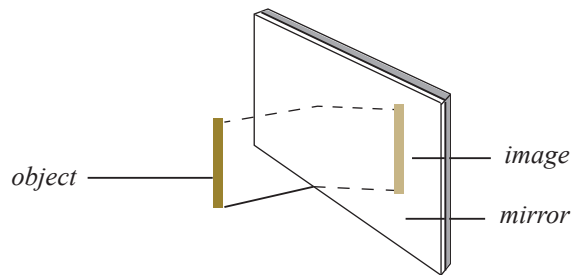

Fig. 5.24: Image of an extended object

Fig. 5.25 shows a ray diagram showing the image of an extended object.

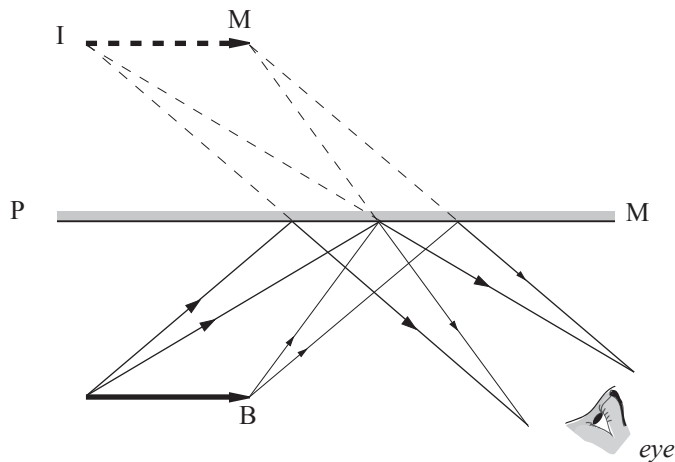

Fig. 5.25: Image formed on a plane mirror

### Lateral inversion

Fig. 5.26 shows the image of a sign board in a mirror as seen by a person keeping the eye at E. The eye sees the letter P in the signboard on the left hand side, but the image of the letter P in the mirror is on the right hand side.

The left hand side of the object becomes the right hand side of the image. We say the image is **laterally inverted**.



Fig. 5.26: Lateral inversion

The same observation is made when you look at yourself in a plane mirror. If your shirt or blouse pocket is on the left side, your image appears to have a pocket on the right hand side. However, the image is upright and of the same size.

From the above observations, we can summarise **the characteristics of images formed by plane mirrors** as follows:

1. The size of the image is equal to the size of the object.
2. The image is erect or upright.
3. The image is virtual i.e cannot be focused on the screen.
4. The distance of the image behind the mirror is equal to the distance of the object in front of the mirror.
5. The image is laterally inverted.

### Example 5.3

What is the angle of reflection in each of the following figures (Fig. 5.27(a) and (b))?

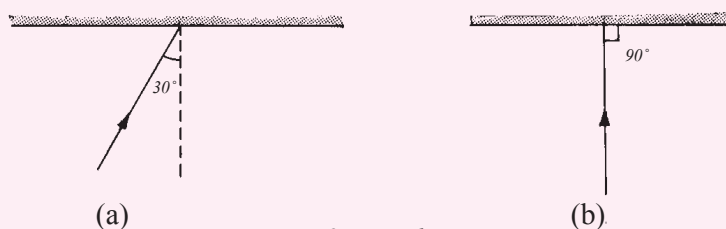

Fig. 5.27: Incident rays

### Solution

In Fig. 5.27(a), the angle of reflection =  $30^\circ$

In Fig. 5.27(b), the incident ray is along the normal. Therefore the angle of incidence =  $0^\circ$ . Hence the angle of reflection =  $0^\circ$ . The ray is bounced back along the normal.

### Example 5.4

Explain with the aid of a ray diagram, how the image of a point object O is seen by the eye (Fig. 13.28(a)).

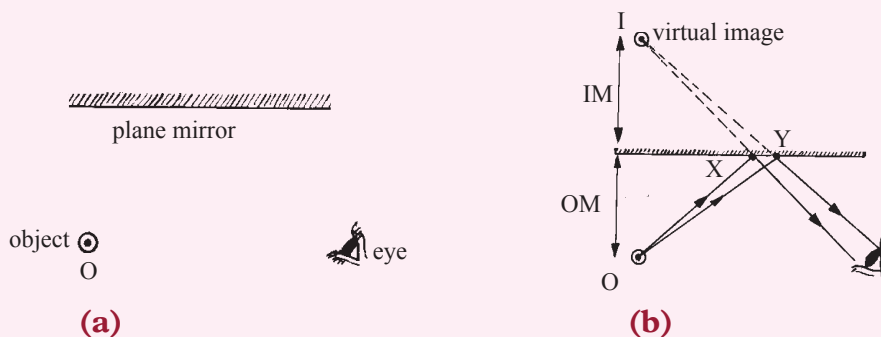

Fig 5.28: Observing how object is reflected by a plane mirror

### Solution

In order to see the image, the reflected rays must reach the eye. The image distance behind the mirror is equal to the object distance from the mirror ( $IM = OM$ ). Hence fix the position of the image first and then draw the two reflected rays from I to reach the eye of the observer. Finally draw the two incident rays OX and OY (Fig. 5.28(b)). Produce the reflected rays back to meet at I.

### Example 5.5

Gasore stood in front of a plane (Fig. 5.29). Use suitable rays to show how he may see his full image in the mirror.

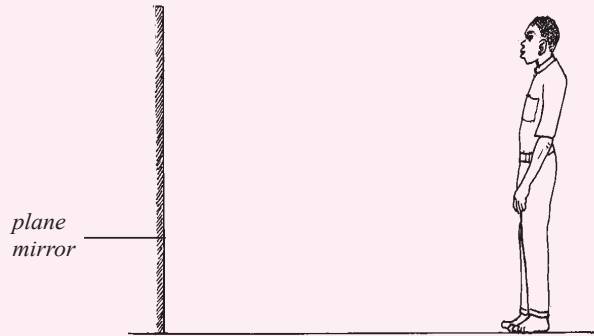

Fig. 5.29: A person standing in front of a plane mirror

### Solution

First fix the images of the head and the toe, say M and I, at equal distances from the mirror. The reflected rays from M and I must reach the eyes of Gasore. Therefore, first draw the reflected rays from M and I to reach the eyes. Draw the incident rays HX and TY. Hence, he can see his full image, IM, in the portion of the mirror XY.

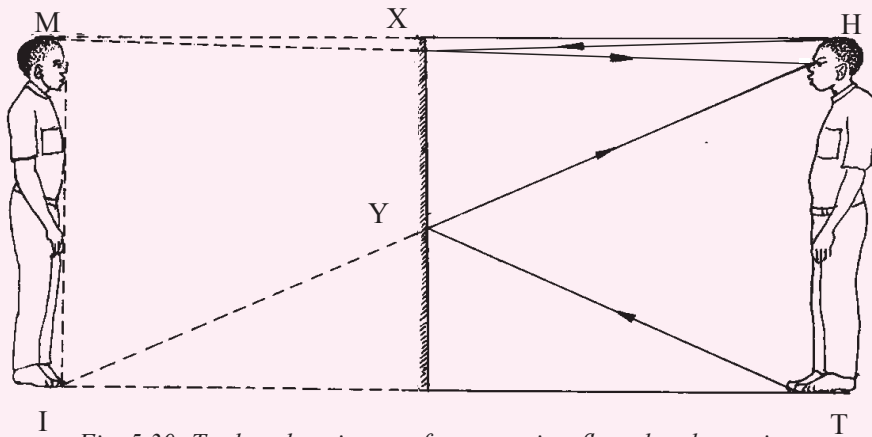

Fig. 5.30: To show how image of a person is reflected a plane mirror

**Note**

Measure XY and the length of the person TH in Fig. 5.30.

The height of the mirror needed XY is always half the height of a person.

**Example 5.6**

The ray OA is incident on mirror  $M_1$  as shown in Fig. 5.31. Draw a second plane mirror  $M_2$  positioned such that the ray OA reflected by mirror  $M_1$  is again reflected by the second mirror  $M_2$  so as to reach the eye of the observer.

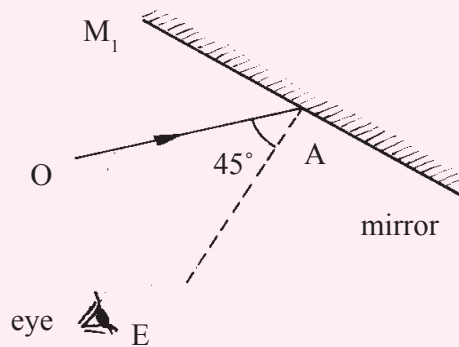
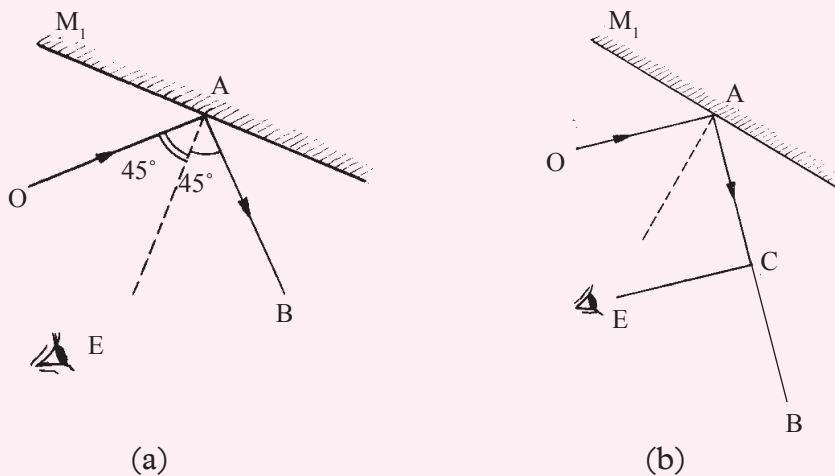
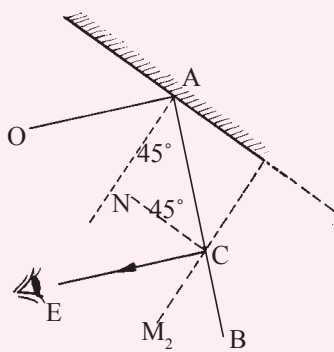

Fig. 5.31: An incident ray

**Solution**

$\angle i = 45^\circ$ , hence  $\angle r = 45^\circ$ . AB is the reflected ray (Fig. 5.32(a)) and it has to be reflected by the second mirror in order to reach the eye. From the eye draw a line to meet the reflected ray AB at C (Fig. 5.32(b)). At C draw a line CN such that it divides  $\angle ACE$  into 2 equal parts (Fig. 5.32(c)). Draw a line  $CM_2$  at C such that it is perpendicular to the line CN (Fig. 5.32(d)). This line  $M_2C$  represents the position of the second mirror  $M_2$  so that the reflected ray can reach the eye.





(c)

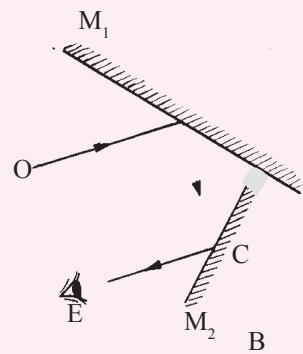

(d)

Fig. 5.32: A path taken by light rays when reflected

### Exercise 5.3

- (a) Define the terms: angle of incidence, angle of reflection, and the normal ray.

(b) What is the relationship between the angle of incidence and the angle of reflection?
- Fig. 5.33 shows a plane mirror on which the angle of incidence is  $30^\circ$ .

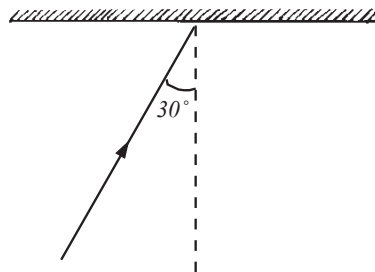

Fig. 5.33: An incident ray at an angle of  $30^\circ$

- What is the angle of reflection?
  - If the angle of incidence is increased to  $40^\circ$ , with the aid of a sketch diagram, show that the angle between the two reflected rays is  $10^\circ$ .
- State the laws of reflection. Suggest a simple experiment to prove that the angle of incidence is equal to the angle of reflection.
  - Show the appearance of a print FG as seen in a plane mirror (Fig. 5.34).



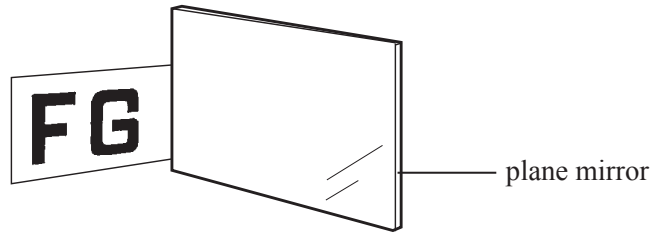

Fig. 5.34: A plane mirror

5. Draw a diagram to show how the eye of a person sees the image of a point object, formed by a plane mirror.
6. A ray of light AB is incident on a mirror  $M_1$  at an angle of  $30^\circ$  as shown in Fig. 5.35. Copy and complete the diagram to show the path of ray AB after reflection from mirror  $M_2$  and hence calculate the angle of reflection from the mirror  $M_2$ .

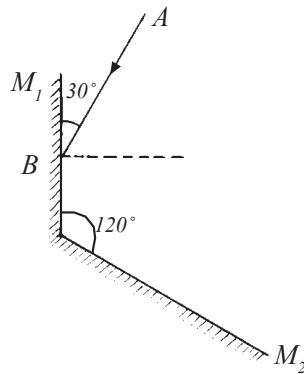

Fig. 5.35: A path taken by light rays when striking a mirror

7. The ray OA is incident on mirror  $M_1$  as shown in Fig. 5.36. Draw a second mirror  $M_2$  positioned such that the ray OA reflected by mirror  $M_1$  is again reflected by the second mirror  $M_2$  so as to reach the eye of the observer.

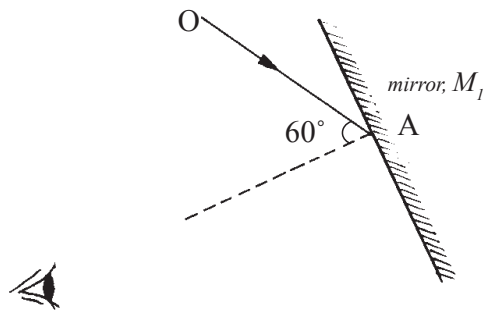

Fig. 5.36: An incident ray striking a mirror

## Numbers of images formed by a plane mirrors at an angle

### Parallel plane mirrors

#### Activity 5.13

To investigate the number of images formed by parallel plane mirror

(Work in groups)

#### Materials

- 2 plane mirrors
- Small object (e.g a small bulb)

#### Steps

1. Using two plane mirrors and a small object to design an experiment to show the images formed by parallel plane mirrors.
2. In your experiment, clearly indicate the procedure you followed, the observation and the conclusion.
3. From the arrangement you have made in your experiment, count the number of images that are formed. Describe how the images are formed by the two plain mirrors in parallel. What are the characteristics of the images formed?
4. Try sketching how the images are formed by the two parallel mirrors.
5. Suggest where the concept being investigated in the activity is applied in real life.

When a bright point object  $O$  (e.g. a small bulb of a torch light) is placed between two parallel mirrors  $M_1$  and  $M_2$  (Fig. 5.37),  $I_1$  is the image formed by the mirror  $M_1$  and  $I_2$  is the image formed by the mirror  $M_2$ .  $I_1$  (a virtual image) acts as an object in front of the mirror  $M_2$  and an image  $I_{1,2}$  is formed behind  $M_2$ .  $I_{1,2}$  acts as an object in front of the mirror  $M_1$  and an image  $I_{1,2,1}$  is formed behind  $M_1$ .

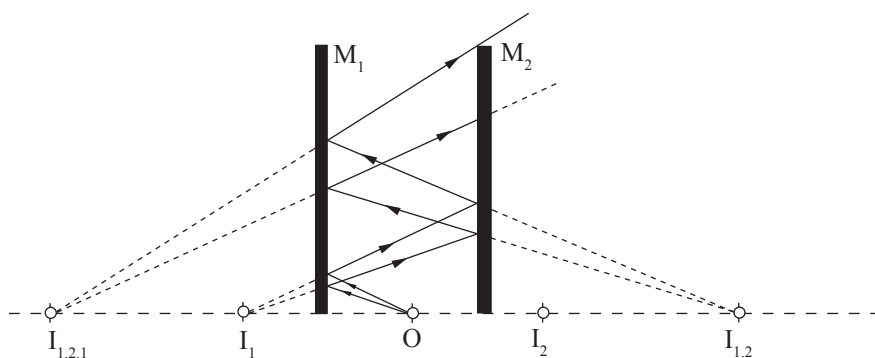

Fig. 5.37: Parallel mirrors

The image  $I_{1,2,1}$  acts as an object in front of the mirror  $M_2$  and forms another image and so on. In this way, the number of images formed is **infinite (countless)**. But the images become dimmer as the distance travelled keep increasing with each reflection. It should be noted that the images of  $I_2$  are not considered in the construction above.

This principle of multiple reflections is used in beauty parlours, tailor and barber shops, etc.

### Plane mirrors inclined at an angle of $90^\circ$

#### Activity 5.14

To find out the number of images formed by two plane mirrors placed  $90^\circ$  to each other

(Work in groups)

#### Materials

- 2 plane mirrors
- An objects (e.g a stone)

#### Steps

1. Draw two lines which are perpendicular to each other i.e at  $90^\circ$ .
2. Place two mirrors along the two lines to touch each other at point of intersection of the lines.
3. Place an object between the two mirrors as shown in Fig 5.38.
4. Look through the two mirrors and count the number of images formed. How many can you count? How are the images formed?

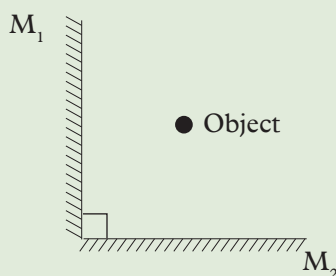

Fig. 5.38: Two perpendicular mirrors

O is a bright point object placed between two plane mirrors  $M_1$  and  $M_2$  as shown in Fig. 5.39.  $I_1$  is the first image formed by  $M_1$ .  $I_2$  is the second image formed by  $M_2$ .

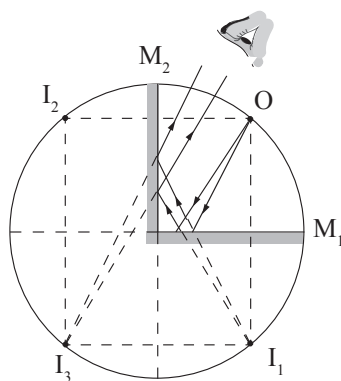

Fig. 5.39: Mirrors inclined at an angle of  $90^\circ$

The virtual image of  $I_1$  in front of the image mirror  $M_2$  forms an image  $I_3$  behind the image of mirror  $M_2$ . Similarly the virtual image  $I_2$  in front of the image of mirror  $M_1$  forms an image behind the image mirror  $M_1$ , which coincides with the image  $I_3$ . Hence **three** images are formed.

### Two plane mirrors inclined at an angle of $60^\circ$

#### Activity 5.15

To observe the images formation by two plane mirrors inclined at an angle of  $60^\circ$

#### Materials

- 2 plane mirrors
- An object (e.g a stone)

#### Steps

1. Draw two lines which are at angle of  $60^\circ$  to each other.
2. Place two mirrors along the two lines to touch one another at point of intersection of the line (Fig. 5.40).
3. Place an object between the two mirrors and count the numbers of images formed. What number do you get?

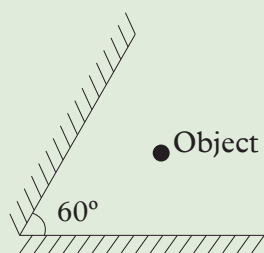

Fig. 5.40: Two mirrors inclined at an angle of  $60^\circ$

4. Now, discuss with your partner Activities 5.14 and 5.15 and deduce a general formula for calculating the number of images formed when two plane mirrors are inclined at an angle.

O is a bright point object placed between the two plane mirrors  $M_1$  and  $M_2$  inclined at an angle of  $60^\circ$  as shown in fig. 5.41. Image  $I_1$  is formed by  $M_1$ . Image  $I_2$  is the second image formed by  $M_2$ .

The virtual image  $I_1$  (in front of  $M_2$ ) forms an image  $I_3$  behind  $M_2$ . Similarly  $I_2$  (in front of  $M_1$ ) forms an image  $I_4$  behind  $M_1$ .  $I_3$  forms an image  $I_5$  due to reflection at  $M_1$  and  $I_4$  forms an image due to reflection at  $M_2$ , which coincides with  $I_5$ . Hence 5 images are formed.

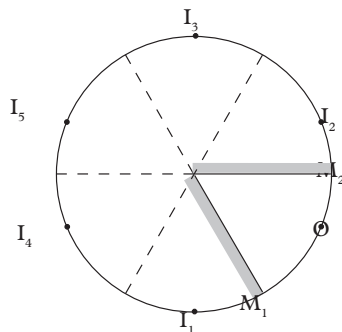

Fig. 5.41: Mirrors inclined at an angle of  $60^\circ$

**The formula to calculate the number of images formed,  $n$ , when two mirrors are inclined at an angle  $\theta$ .**

When angle  $\theta$  is  $90^\circ$ , the number of images formed,  $n$ , is 3. i.e.

$$n = \frac{360^\circ}{90^\circ} - 1 = 3$$

When the angle  $\theta$  is  $60^\circ$ , the number of images formed,  $n$ , is 5 i.e.

$$n = \frac{360^\circ}{60^\circ} - 1 = 5$$

In general if the angle between 2 mirrors is  $\theta$ , the number of images formed  $n$ , is given by.

$$n = \frac{360^\circ}{\theta} - 1$$

## 5.8 Applications of reflection at plane surfaces

### Activity 5.16

To find out the applications of reflection at plane surfaces

#### Materials

- Reference books
- Internet

#### Steps

1. Conduct research from internet and reference books on the applications of reflection at plane surface.
2. In your research, identify the devices in which reflection is applied and how they work.
3. Let your secretary note down the key points from your research after the discussion.
4. Present your findings to the whole class through your group leaders

### Periscope

A periscope is a device which enables us to see over the top of an obstruction (e.g. a wall). As shown in Fig. 5.42, a periscope uses two plane mirrors kept parallel to

each other and the polished surfaces facing each other. Each plane mirror makes an angle of  $45^\circ$  with the horizontal. Light from the object OB is turned through  $90^\circ$  at each mirror and reaches the eye.

The final image produced IM is virtual, erect and the same size as the object. The lateral inversion produced by the two plane mirrors cancel out each other.

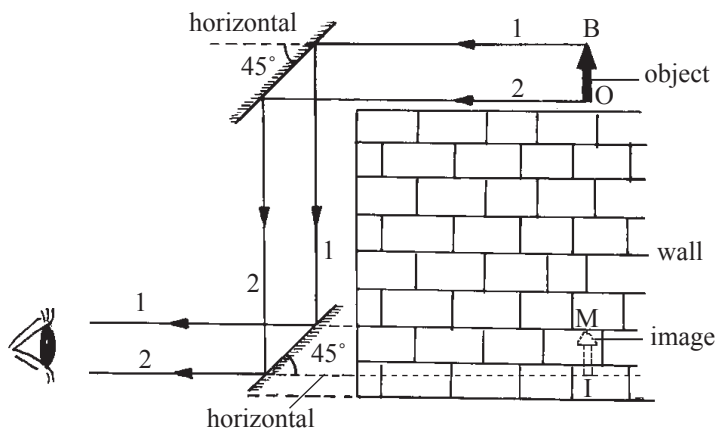

Fig. 5.42: A periscope

### Exercise 5.4

1. (a) What is a periscope?  
(c) State the size and nature of the image formed by a periscope.
2. Draw a simple ray diagram to show the working of a periscope.
3. (a) Two plane mirrors are kept inclined to each other. Calculate the number of images formed for the following angles of inclination
 

(i) $120^\circ$	(ii) $90^\circ$
(iii) $60^\circ$	(iv) $30^\circ$
- (b) Which of the above set up is used in the construction of a kaleidoscope?
4. A bright point object O is placed between two parallel plane mirrors  $M_1$  and  $M_2$  as shown in Fig. 5.43. (not drawn to scale).

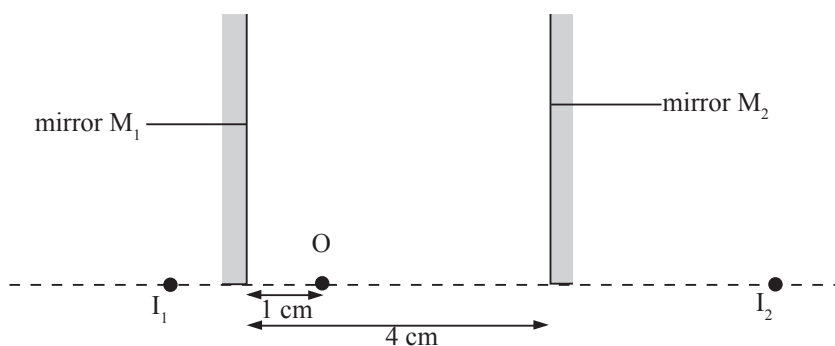

Fig. 5.43: Reflection of an object by parallel plane mirrors

For the object O, mirror  $M_1$  forms a virtual image  $I_1$  behind the mirror  $M_1$ .  $I_2$  is the image of O in the mirror  $M_2$ . Show that the image of  $I_2$  due to the mirror  $M_1$  is 6 cm behind the image  $I_1$ .

## 5.9 Project work

### Construction of pinhole camera

#### Suggested materials

An old cardboard shoe-box or a carton of size 40 cm  $\times$  15 cm  $\times$  12 cm, a sewing needle or a paper pin, grease proof paper, tracing paper or frosted glass, black paint and brush or black paper (optional), a black cloth big enough to cover the box and the head of the viewer (optional).

#### Assembly

- If black paint is available, paint the inside of the box black or stick black paper inside. Pierce a small hole with the tip of a needle or pin on one side. Cut a small opening on the opposite side and paste a grease proof paper or a tracing paper (any translucent material will be sufficient).

#### How to use the assembled model

- Place the box so that the pin hole faces a bright object, say a building on a sunny day (or a candle in a semi dark room) . View the translucent screen (Fig. 5.44).
- Cover the box and the head of the viewer with a black cloth to cut off any stray light entering the box or falling on the translucent screen.

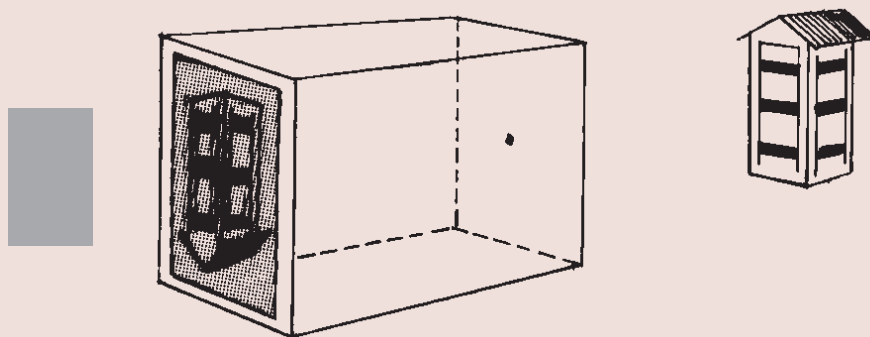

Fig. 5.44: A pinhole camera

## Construction of a periscope

### Working model

#### Materials needed

Retort stands, boss and clamp, small pieces of wood or old erasers to hold the mirrors firmly without breaking, candle.

#### Assembly

- Set up the two mirrors at an angle of  $45^\circ$ , with the horizontal and the silvered surfaces facing each other as shown and look for the image (Fig. 5.45).

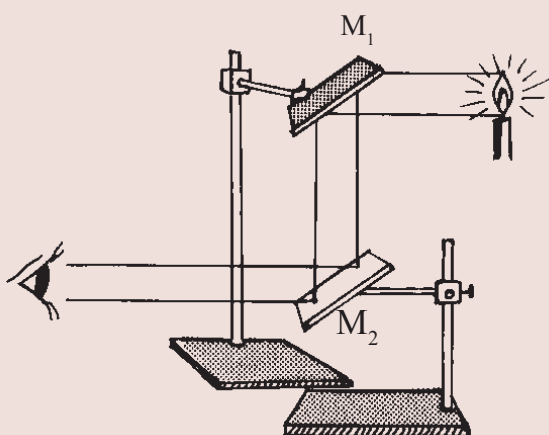

Fig. 5.45: A model periscope

## Project: Construction of a periscope

### Suggested materials

A narrow long cardboard box (e.g. tennis ball/ shuttle cock containers) or a carton of cardboard of size  $40\text{ cm} \times 5\text{ cm} \times 5\text{ cm}$ , two plane mirrors ( $5\text{ cm} \times 5\text{ cm}$ ), adhesive tapes, a razor blade or a pair of scissors.

#### Assembly

- Insert the two mirrors, one at the top and the other at the bottom at an angle of  $45^\circ$  to the line joining the mirrors (mirror adjustments can be made later when the image is viewed). Cut suitable openings near each mirror (Fig. 5.46).



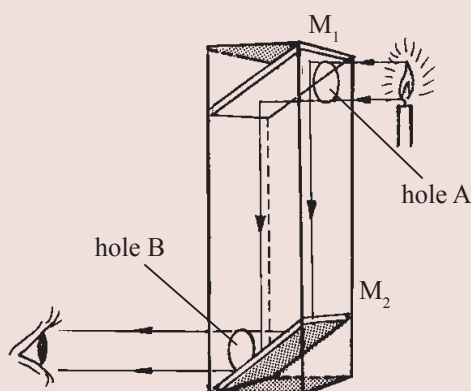

Fig. 5.46: A periscope

### How to use the constructed periscope

A candle is held near the opening A and the image is seen through the opening B.

### Topic summary

- Light is a form of energy in wave form.
- Light helps us to see objects.
- Light travels in a straight line. This property of light is called the rectilinear propagation of light.
- A substance through which light can pass through is a medium.
- A shadow is a region where light does not reach.
- Formation of shadows and pinhole cameras are direct evidences for the rectilinear propagation of light.
- Magnification (m) =  $\frac{\text{height of the image}}{\text{height of the object}} = \frac{\text{image distance}}{\text{object distance}}$
- A plane mirror bounces light back into the same medium. The angle of incidence is equal to the angle of reflection.
- A plane mirror forms an image of the same size as the object. The image is erect and laterally inverted. The distance of the image from the mirror is the same as the distance of the object from the mirror.
- Periscopes use the properties of light reflected in plane mirrors.



7. Draw the reflected ray of light for the incident ray shown in Fig. 5.49. Now draw a second mirror like the first mirror arranged so that the reflected ray is again reflected. The reflected ray should be parallel to the original path but in the opposite direction.

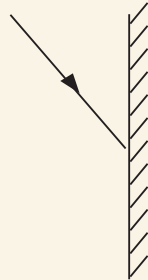

Fig. 5.49: A ray striking a mirror

8. A triangular object ABC is on one side of a vertical mirror (Fig. 5.50). Draw the image formed by the mirror.

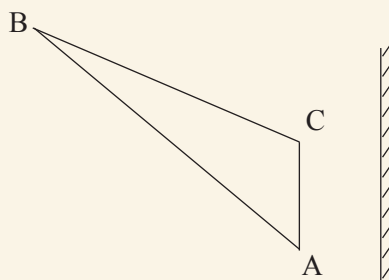

Fig. 5.50: A triangular object in front of a mirror

9. Fig. 5.51 shows the path of light PQRS in a simple optical fibre which undergoes reflection. Calculate the angle between the rays PQ and RS.

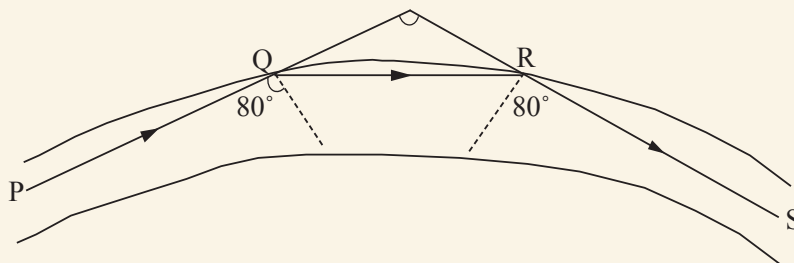
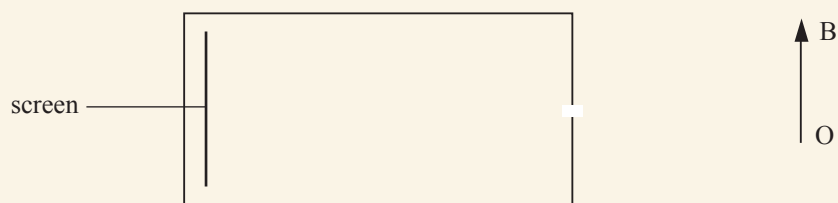

Fig. 5.51: A path taken by a light ray

10. Distinguish between solar and lunar eclipses.
11. (a) Describe a project on how to make a periscope.  
 (b) Explain how a captain uses a periscope to see oncoming ship.

- 12.** Draw rays from the object OB to show the image formed by a pinhole camera on a screen (Fig. 5.52). Is the image upright or inverted? Is the image real or virtual?



*Fig. 5.52: Object in front of a pinhole camera*

- 13.** State and explain the effect on the image formed in a pinhole camera if:
- (a)** The object distance is decreased.
  - (b)** The length of the box used is decreased.
- 14.** A pinhole camera forms an image of size 10 cm. The object is 5 m tall and 10 m away from the pinhole. Calculate the length of the pinhole camera.
- 15.** Describe how a kaleidoscope works.

## Topic Outline >>>

- Introduction
- Phenomena of refraction of light
- Laws of refraction of light
- Refraction index
- Principle of reversibility of light
- Real and apparent depth
- Critical angle and total internal reflection of light
- Refraction of light in a prism

## Introduction

We have learnt that light travels in a straight line. We also looked at reflection of light at plane surfaces and characteristics of images formed under the plane mirror. In this topic, we will introduce another property of light. In general life, we have observed that:

1. A thin rod dipped obliquely into water appears to be bent at the water surface.
2. A pool of water appears to be shallower than it actually is.
3. A colourful rainbow is formed in the atmosphere usually after some rainfall.
4. A ‘shimmering’ pool of water seems to be ahead of a traveller on tarmac road or desert sand on a hot day.

Explain these phenomena to your classmates.

These and many other similar effects are caused by a property of light called *refraction* of light.

## 6.1 Phenomena of refraction of light

The following activities will help us illustrate the refraction of light.

## 6.1.1 Demonstrations of refraction of light

### Activity 6.1

#### To demonstrate the refraction of light

(Work in groups)

#### Materials

- Plastic ruler
- Water in a transparent container

#### Steps

1. Dip a plastic ruler into a transparent container of clean water
2. View the ruler from the top and the side of the container (Fig. 6.1). What do you observe on the shape of the ruler? Explain.
3. Why do you think such an observation is made?

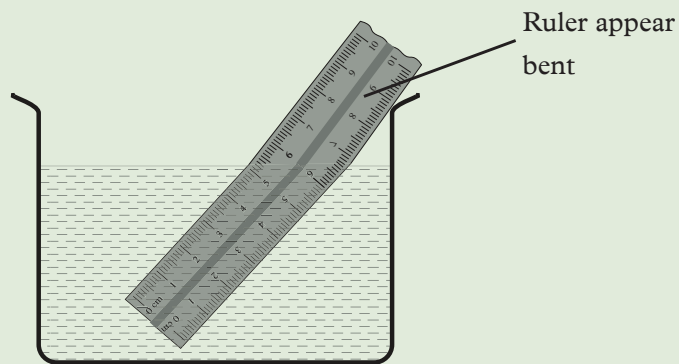

Fig. 6.1: Appearance of a ruler in water.

The ruler appears to be bent at the point where it enters into water. This is because light rays change direction (bend) when traveling from air to water. Therefore, a ruler appears bent due to refraction of light. (see Fig. 6.2)

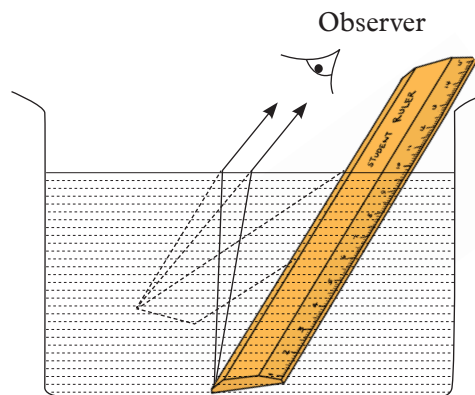

Fig. 6.2: Appearance of a ruler in water.

## Activity 6.2

### To demonstrate how light rays travel using a rectangular glass block

#### Materials

- A rectangular glass block.
- A ray box.

#### Steps

1. Pass a narrow beam of light through a rectangular glass block in a semi-dark room and observe the path of light (Fig. 6.2).

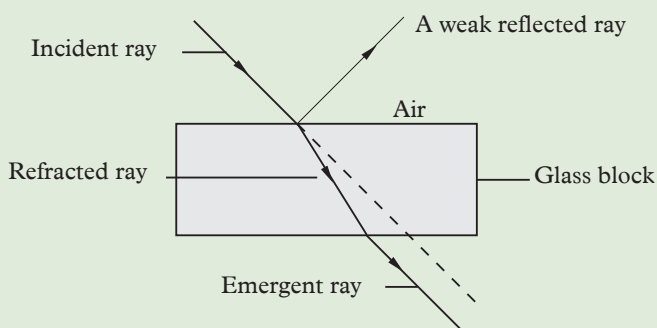

Fig. 6.3: A ray of light passing through a rectangular glass block.

2. Draw the different sides of the glass block. Draw the incident ray and the emergent ray. Change the angle of incident ray a few times. Each time draw the emergent ray. What is the relationship between angles and parallel nature of rays?
3. Design an experiment using pins to show how light rays travel.

The direction of the ray of light inside the glass changes. Some of the light is also reflected from the surface of glass. The emergent ray is parallel to the incident ray.

In all the above experiments, when light travels from air to another medium like water or glass and vice versa, there is a change in the direction of the path of light at the boundary of the two media. This property of light is called *refraction*.

When light travels from one medium to another of different optical density, it bends. The bending of light is called *refraction*.

Refraction of light is the bending of light rays when they travel from one medium to another of different optical density. Also, refraction is the change of direction when light rays travel from one medium to another.

Refraction is caused by the change of velocity of light as it travels from one medium to another. Experiments show that the velocity of light in air (referred to as a vacuum as we shall cover later in this topic) is  $3 \times 10^8$  m/s. The velocity of light is less in all the other media. Hence air is considered as an optically *rarer medium*. All the other media, are considered as optically *denser media than air*.

## 6.1.2 Terms associated with refraction of light

Consider a rectangular glass block ABCD (Fig. 6.4). AB is a boundary that separates the two media i.e. air and glass. Ray PQ travelling in air is incident at the point Q at the boundary. On entering the glass, the ray travels along a path QR (Activity 6.4). NQM is the normal drawn at Q to the line AB.

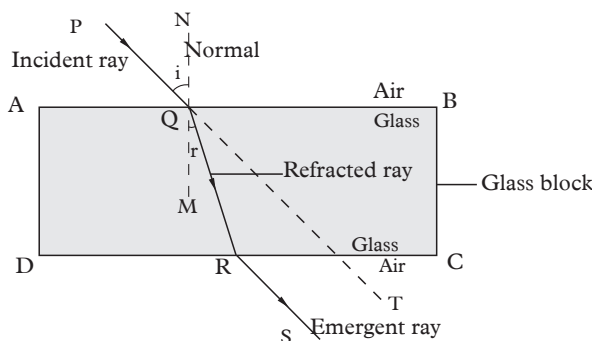

Fig. 6.4: Terminologies used in refraction of light.

The ray PQ is the *incident ray* and the ray QR is the *refracted ray*. The angle PQN, between the incident ray and the normal, is the *angle of incidence*,  $i$ . The angle RQM, between the refracted ray and the normal, is the *angle of refraction*,  $r$ . The ray RS is the *emergent ray*. As seen in Fig. 6.4 the emergent ray RS is parallel to the incident ray PQ, shown by the dotted line QT.

A ray passing from a rarer medium to a denser medium bends *towards the normal*. On the other hand, a ray passing from a denser medium to a rarer medium bends *away from the normal* (Fig. 6.4).

At the boundary or the surface that separates the two media, there is a change in velocity of light that causes the change of direction. However, if light travels at right angles to the boundary as shown in Fig. 6.5 (c) there is no change in direction. Light continues to travel in a straight line but the speed of light is reduced in the glass. This is, sometimes, referred to as the *normal refraction*.

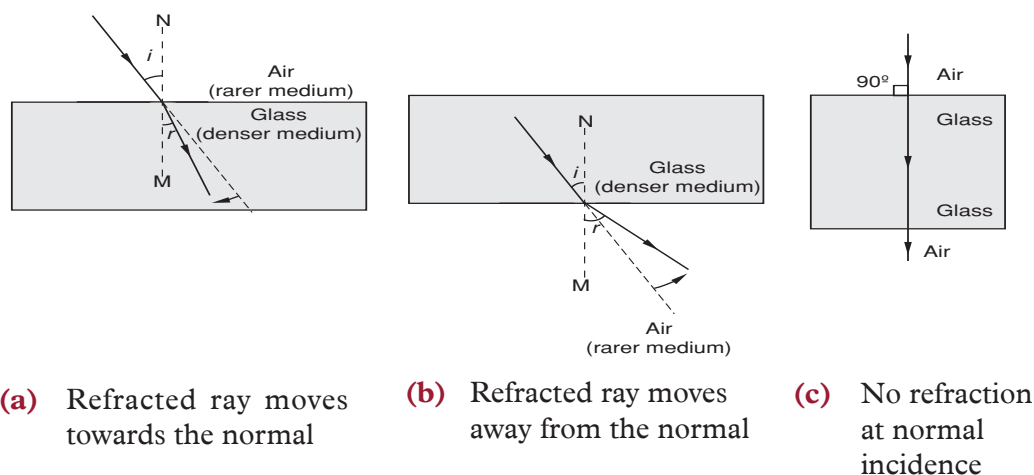

Fig. 6.5: Refraction of light in different media



## Exercise 6.1

1. Define the term:  
(a) Refraction of light                      (b) Angle of incidence
2. Explain why light bends when it travels from one medium to another.
3. Draw diagrams to illustrate refraction for a ray of light on:  
(a) Glass – air boundary                      (b) Water – air-glass boundaries  
(c) Water – glass boundary
4. Complete the ray in Fig. 6.6 to show refraction.

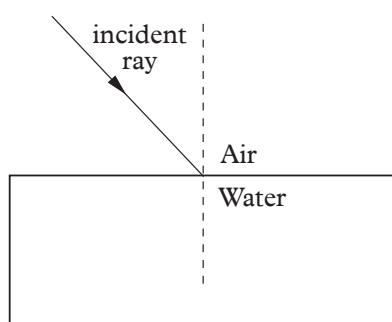

Fig. 6.6: Refraction of light

### 6.1.3 Laws of refraction of light

Many scientists have contributed in the study of refraction of light. One such scientist who discovered the relationship between the angle of incidence and the angle of refraction was **Willebrord Snell**.

The following experiments will help in establishment of the relationship between angle of incidence and the angle of refraction.

#### Activity 6.3

**To investigate the relationship between the angle of incidence and the angle of refraction**

#### Materials

- A thick glass block
- A paper protractor
- A ray box

#### Steps

1. Fix on the top of a table a thin circular “paper protractor” graduated in degrees as shown in Fig. 6.7.

- Place a rectangular glass block ABCD such that the edge AB coincides with the 90°–90° mark of the protractor. The line along 0°–0° mark represents the normal NQM at Q.

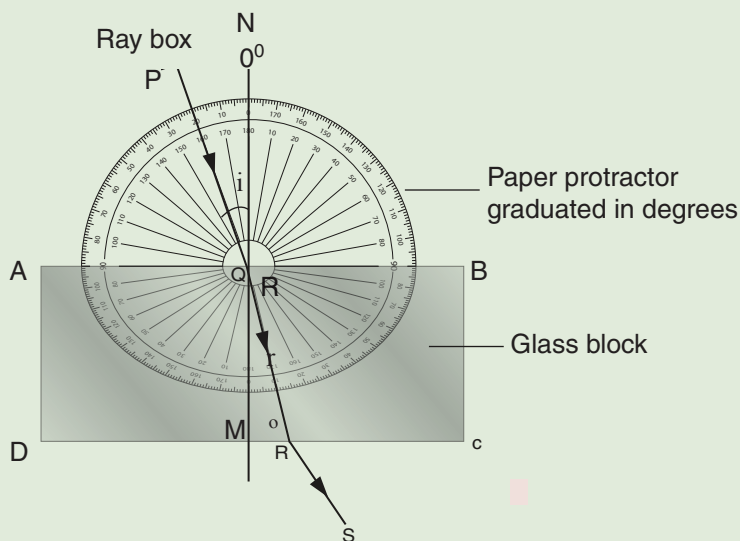

Fig. 6.7: Relationship between the angle of incidence and the angle of refraction

- Using a ray box, in a semi-dark room, pass a ray of light through the glass block at an angle of incidence,  $i$ , say  $20^\circ$ . Measure the angle of refraction,  $r$ .
- Repeat the experiment for different angles of incidence and measure the corresponding angles of refraction.
- Record the results in a table similar to Table 6.1. Complete the other columns in the table. What do you notice about the ratio of  $\sin i$  to  $\sin r$ , i.e.  $\frac{\sin i}{\sin r}$ ?

Table 6.1

$i^\circ$	$r^\circ$	$\sin i$	$\sin r$	$\frac{\sin i}{\sin r}$
20				

- Use your conclusion to state the law of refraction.

### In summary

- The ratio  $\frac{\sin i}{\sin r}$  is *practically* a constant.
- The incident ray, the refracted ray and the normal all, lie in the same plane at the point of incidence.

The two observations constitute the laws of refraction.

### Laws of refraction

1. The incident ray, the refracted ray and the normal, at the point of incidence, all lie in the same plane.
2. The ratio of the sine of the angle of incidence to the sine of the angle of refraction is a constant for a given pair of media (Snell's law) i.e

$$\frac{\sin i}{\sin r} = \text{constant}$$

The expression  $\frac{\sin i}{\sin r} = \text{constant}$  is the mathematical expression of Snell's law.

### Activity 6.4

#### To verify Snell's law using pins and a glass block

#### Materials

- White plain paper
- Softboard
- Four pins
- A glass block
- A ruler

#### Steps

1. Fix a white plain paper on a softboard. Draw a line XY and mark its midpoint Q. At Q draw a normal NQM perpendicular to XY and a line PQ such that the angle of incidence,  $i$ , ( $\angle PQN$ ) is  $20^\circ$ .
2. Place a rectangular glass block such that the midpoint of the edge AB coincides with the midpoint Q of the line XY (Fig. 6.8). Draw the outline of the glass block ABCD.
3. Stick two pins  $O_1$  and  $O_2$ , called the *object pins* on the straight line PQ vertically into the softboard about 5.0 cm apart. View from the side CD and look for the images of the first two pins.
4. Keeping the eye along the plane of the paper, move the head to and fro slowly until in one particular position the images of the two pins lie on a straight line.
5. Fix a third pin  $S_1$  called the *search pin*, such that this pin and the images of the first two pins as seen through the glass block lie along the same straight line.

6. Repeat the above procedure with the fourth pin  $S_2$ , so that the images of the pins  $O_1$  and  $O_2$  and the search pins  $S_1$  and  $S_2$  lie along the same straight line.
7. Using a pencil, mark the positions of the four pins with a small circle and remove the pins and the glass block.
8. Join the points  $S_2$  and  $S_1$  to meet the line DC at R. Join points  $O_2$  and  $O_1$  to meet at Q. Join Q to R to make line QR. QR is the refracted ray in the glass for the incident ray PQ in air. Measure the angle of refraction,  $r$ , ( $\angle MQR$ ).

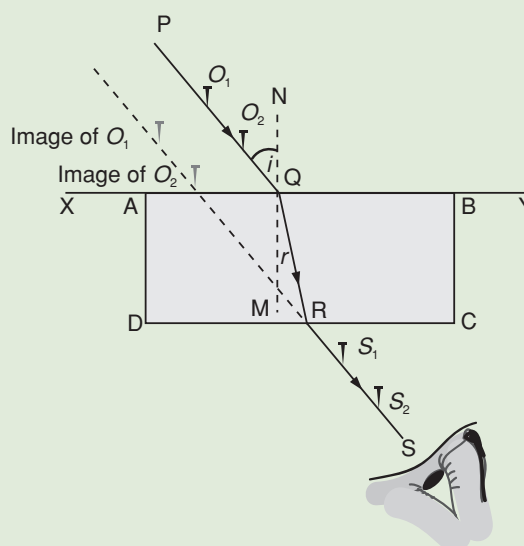

Fig. 6.8: Verifying Snell's law.

9. Repeat the experiment for different angles of incidence and record the readings in a table similar to Table 6.1.
10. What do you observe on the column  $\frac{\sin i}{\sin r}$ ? What does it represent?

Once again it is seen that the ratio  $\frac{\sin i}{\sin r}$  is a constant for the two given media.

Draw a graph of  $\sin i$  (y-axis) against  $\sin r$  (x-axis).

The graph drawn is a straight line passing through the origin. The gradient of the graph gives  $\frac{\sin i}{\sin r}$  which is a constant.

Snell's law states that for two refracting media, the ratio of the sine of the angle of incident to the sine of the angle of refraction is a constant.

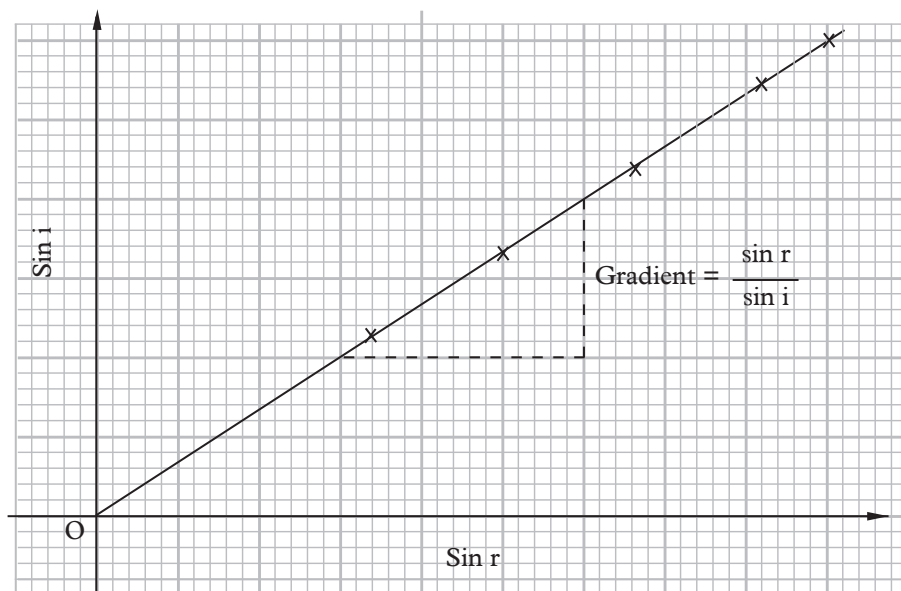

Fig. 6.9: Graph of  $\sin i$  against  $\sin r$

### 6.1.4 Refractive index

The refractive index ( $n$ ) is the measure of bending of light i.e the ratio of sine of angle of incident to the sine of angle of refraction (hence Snell's law).

Snell's law can also be stated as  $\frac{\sin i}{\sin r} = \text{a constant}$ .

This constant is known as *refractive index*,  $n$  or *index of refraction*. Therefore,

Refractive index ( $n$ ) =  $\frac{\sin i}{\sin r}$       It has no units

Since refractive index is the property of two media, it is necessary to indicate them. If, for example, light travels from air to glass the ratio  $\frac{\sin i}{\sin r}$  is found to be 1.50. This is the refractive index of glass with respect to air. We can rewrite this using the following symbols.

$${}_{\text{air}}n_{\text{glass}} = 1.50 \quad \text{i.e. } n_{\text{g}} = 1.50$$

The *absolute refractive index* of a medium is the value of  $n$  when the first medium is a vacuum.

The absolute refractive index of a medium  $n = \frac{\sin i}{\sin r}$  where the angle of incidence is in a vacuum and the angle of refraction is in the medium

The difference between the refractive indices of air and vacuum is very small and hence the refractive index of a medium with respect to air is taken as the absolute refractive index (unless extreme accuracy is required).

$$\text{Refractive index of a medium } (n) = \frac{\sin i}{\sin r}$$

Where the angle of incidence is in air and the angle of refraction is in the medium

The refractive index of a medium can also be expressed in terms of velocity of light in the media.

Refractive index is the ratio of velocity of light in a vacuum to velocity of light in a medium.

$$\text{Refractive index of a medium} = \frac{\text{velocity of light in vacuum}}{\text{velocity of light in the medium}}$$

$$n = \frac{c}{v}$$

Table 6.2 gives the refractive indices of some substances with respect to air (taking the refractive index of air as 1.00). Materials with higher refractive indices bend light more than those with lower refractive indices.

Table 6.2

Solid	refractive index (n)	Liquid	refractive index (n)
Ice	1.31	Water	1.33
Glass (crown)	1.50	Alcohol	1.36
Glass (flint)	1.65	Paraffin	1.44
Ruby	1.76	Glycerine	1.47
Diamond	2.40	Turpentine	1.47

### Example 6.1

A ray of light passing from air to glass is incident at an angle of  $30^\circ$ . Calculate the angle of refraction in the glass, if the refractive index of glass is 1.50.

#### Solution

$$\text{Refractive index of glass } n_g = \frac{\sin i}{\sin r}$$

$$\therefore \sin r = \frac{\sin i}{n_g} = \frac{\sin 30^\circ}{1.50} = \frac{0.50}{1.50} = 0.33$$

$$\therefore r = 19.5^\circ$$

The angle of refraction in glass is  $19.5^\circ$

### Example 6.2

In Fig. 6.10 calculate the refractive index of glass.

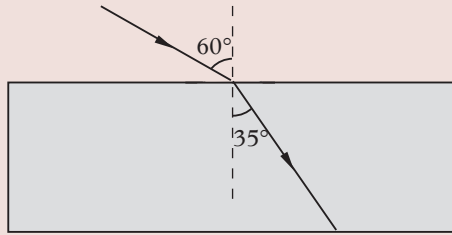

Fig. 6.10: Glass block

### Solution

$$\text{Refractive index of glass } ({}_a n_g) = \frac{\sin i}{\sin r} = \frac{\sin 60^\circ}{\sin 35^\circ}$$

$${}_a n_g = \frac{0.866}{0.574} = 1.51$$

The refractive index of glass is 1.51.

### Example 6.3

The angle of incidence for a ray of light passing from air to water is  $30^\circ$  and the angle of refraction is  $22^\circ$ . Calculate the refractive index of water.

### Solution

$$n_{\text{water}} = \frac{\sin i}{\sin r} = \frac{\sin 30^\circ}{\sin 22^\circ} = \frac{0.500}{0.375} = 1.33$$

$\therefore$  The refractive index of water is 1.33 (hence  ${}_a n_w = 1.33$ )

### Example 6.4

Calculate the refractive index of water, given that the velocity of light in air is  $3 \times 10^8$  m/s and velocity of light in water is  $2.25 \times 10^8$  m/s.

### Solution

$$n_w = \frac{\text{velocity of light in air}}{\text{velocity of light in water}} = \frac{3 \times 10^8 \text{ m/s}}{2.25 \times 10^8 \text{ m/s}} = 1.33$$

### Example 6.5

The velocity of light in glass is  $2.0 \times 10^8$  m/s. Calculate (a) the refractive index of glass and (b) the angle of refraction in the glass for a ray of light passing from air to glass at an angle of incidence of  $40^\circ$ .

#### Solution

$$\text{(a)} \quad {}_a n_g = \frac{C_{\text{air}}}{V_{\text{glass}}} = \frac{3 \times 10^8 \text{ m/s}}{2 \times 10^8 \text{ m/s}}$$
$${}_a n_g = 1.50$$

$$\text{(b)} \quad {}_a n_g = \frac{\sin i}{\sin r} = 1.50$$

$$\sin r = \frac{\sin i}{1.50} = \frac{\sin 40^\circ}{1.50} = 0.428$$

$$r = \sin^{-1} 0.428$$
$$= 25.4^\circ$$

### 6.1.5 The principle of reversibility of light

Just like light rays travel from medium 1 to a medium 2, it also travels in the reverse direction i.e travel from the medium 2 to medium 1. This is known as *the principle of reversibility of light*. It states that light will follow exactly the same path if its direction of travel is reversed. The following experiment will help us to establish that light rays can travel from a medium to air or vacuum and back through the same path.

#### Activity 6.5

#### To verify the principle of reversibility of light

##### Materials

- A glass-air boundary
- Plane mirror

##### Steps

1. Place a plane mirror M perpendicular to the refracted ray of light QR as shown in Fig. 6.11.

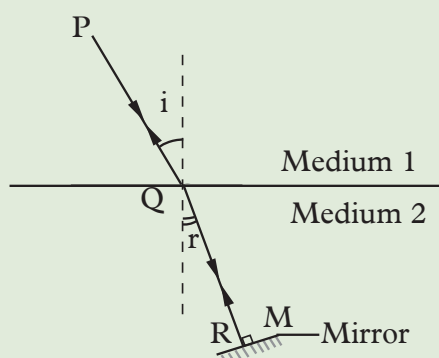

Fig. 6.11: The principle of reversibility of light



2. Observe what happens to the reflected ray. Explain your observation. What path does the ray follow? Can you be able to state the law of reversibility of light?

In this activity, the reflected ray is reversed along RQ and is refracted through QP in medium 1.

This means that the ray retraces its entire path. This is the principle of *reversibility of light*.

$$\text{From Snell's law, } {}_1n_2 = \frac{\sin i}{\sin r}$$

$$\text{For the reversed path, } {}_2n_1 = \frac{\sin r}{\sin i}$$

By multiplying the respective sides of the above two equations we get

$${}_1n_2 \times {}_2n_1 = \frac{\sin i}{\sin r} \times \frac{\sin r}{\sin i} = 1$$

$${}_1n_2 \times {}_2n_1 = 1.$$

$$\text{Therefore, } {}_1n_2 = \frac{1}{{}_2n_1}$$

The refractive index for a ray moving from air to water is 1.33 but when the ray moves from water to air the refractive index is  $\frac{1}{1.33} = 0.75$ .

### Exercise 6.2

1. Define the term refractive index.
2. (a) State the laws of refraction.  
(b) Describe an experiment to determine the refractive index of a rectangular glass block.
3. A ray of light is passing from air into water along PQ. The ray strikes the bottom surface at T instead of R as shown in Fig. 6.12. Calculate:

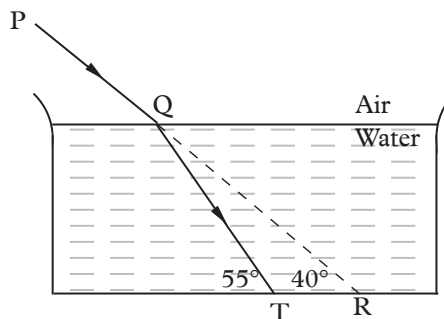

Fig. 6.12: A ray passing air-water interface

- (a) The angle of incidence
  - (b) The angle of refraction
  - (c) The refractive index of water.
4. Copy and complete Fig. 6.13 to show the path of light through and out of the glass block of refractive index 1.50.

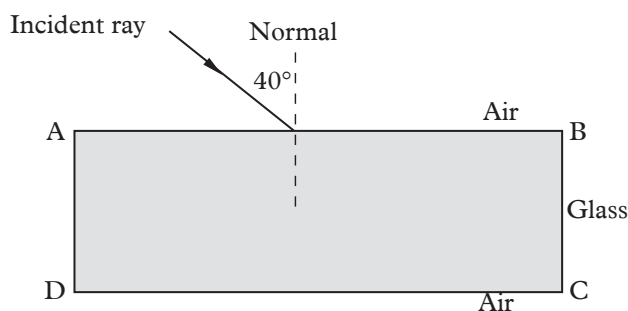

Fig. 6.13: Glass block

5. Light travels through glass of refractive index 1.60 with a speed of  $v$  m/s. Calculate the value of  $v$ , if the speed of light in air is  $3.0 \times 10^8$  m/s.
6. In a semicircular glass block for the incident ray PQ inside glass, QR is the refracted ray in air as shown in Fig. 6.14.

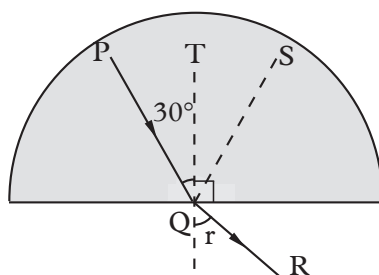

Fig. 6.14: Semi circular glass block

- (a) What do the dotted lines QS and QT represent?
  - (b) Calculate the angle of refraction,  $r$ , in air, if the refractive index of glass is 1.50.
7. State Snell's law of refraction. Describe an experiment to verify it.
8. Table 6.3 shows the angles of incidence  $i$  and the angles of refraction,  $r$ , when light passes from air to glass. Complete the table and draw a graph of  $\sin r$  (y-axis) against  $\sin i$  (x-axis). From the graph determine the refractive index of glass.

Table 6.3

$i^\circ$	$r^\circ$	$\sin i$	$\sin r$
15	10		
30	19		
45	28		
60	35		

### 6.1.6 Real and apparent depth

#### Activity 6.6

To illustrate real and apparent depth

#### Materials

- Water in a transparent container
- A coin

#### Steps

1. Place the coin at the bottom of the container with water.
2. From the top position your eyes perpendicularly to the coin and look at it. Do you see the coin? Where is it?
3. Now shift eye to an angle and look again at the coin. Where do you see it?
4. Explain your observations in steps 2 and 3.
5. Discuss with your classmates what real and apparent depth are. Deduce the relationship between the two.

In activity 6.1, we saw that a ruler appear to be bent at the point where it enters into the water which was a denser medium in that case. Fig. 6.15 shows how to locate the image of an object in a denser medium (glass) using a ray diagram.

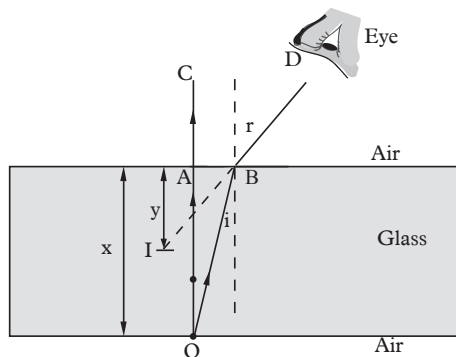

Fig. 6.15: Image formation in a glass block

A ray OA is incident along the normal. The ray goes undeviated as AC at the

surface of the two media. Another ray OB, incident obliquely at B and close to A bends away from the normal and proceeds along BD. When DB is produced backwards, it meets OC at I. This is the position of the virtual image of the object O. OA ( $x$ ) is the *real depth* of the object below the surface of separation. IA ( $y$ ) is the *apparent depth* of the image below the surface of separation.

### The relationship between refractive index, real depth and apparent depth

Fig. 6.16 shows the image I of an object O inside water. Point B is very close to point A.

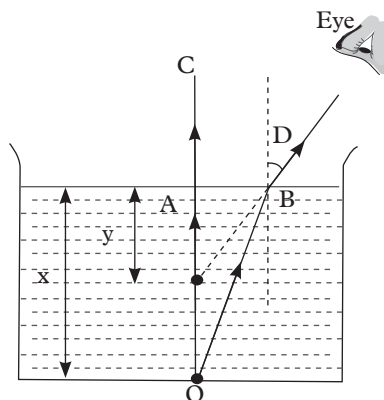

Fig. 6.16: Real and apparent depth

From the Snell's law  $n_w n_a = \frac{\sin i}{\sin r}$

By the principle of reversibility of light,

$${}_a n_w = \frac{\sin r}{\sin i}$$

$\angle AOB = i$  (alternate angles);  $\angle AIB = r$  (corresponding angles)

$$\sin r = \frac{AB}{IB} \quad \text{and} \quad \sin i = \frac{AB}{OB}$$

$${}_a n_w = \frac{\sin r}{\sin i} = \frac{\frac{AB}{IB}}{\frac{AB}{OB}} = \frac{AB}{IB} \times \frac{OB}{AB} = \frac{OB}{IB}$$

Since B is very close to A then  $\frac{OB}{IB} = \frac{OA}{IA}$

Therefore,  ${}_a n_w = \frac{OA}{IA} = \frac{x \text{ (real depth)}}{y \text{ (apparent depth)}}$

hence  ${}_a n_w = \frac{\text{real depth}}{\text{apparent depth}}$

This relation can be used to determine the refractive index of a transparent solid or a liquid. Since the refractive index of a denser medium is greater than 1,  $y$  is always less than  $x$ . Thus the image of an object situated in a denser medium appears to be raised towards the surface. For example, if a pool of water is 4 m deep, the apparent depth of the pool is given by

$$y = \frac{x}{n} = \frac{4.00}{1.33} = 3.0 \text{ m}$$

### Activity 6.7

### To determine refractive index of water using two pins

#### Materials

- A beaker with water
- A clamp and stand
- 2 search pins
- A ruler

#### Steps

1. Take a beaker containing clean water and measure the **real depth**  $x$  from the base of the beaker to the water surface. Place an object pin O inside the beaker and adjust its position so that the tip of the pin just touches the edge of the beaker.
2. Locate the image of the object pin by keeping the eye vertically above water. Adjust the position of the search pin S by moving it upwards or downwards slowly till its tip and the tip of the image pin as seen through water move together when the eye is moved across the beaker to and fro.
3. Fix the search pin S at this position (Fig. 6.17). Measure the **apparent depth**.

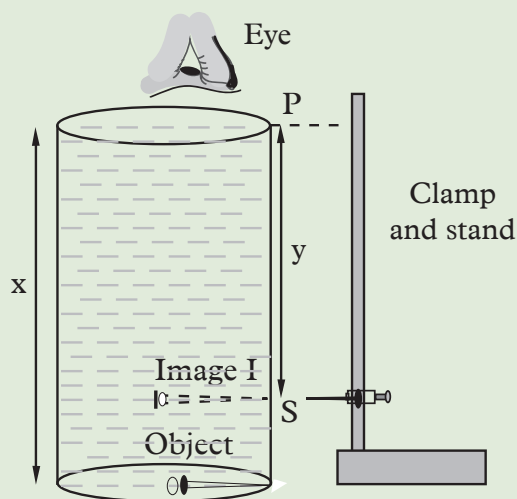

Fig. 6.16: Refractive index of water using two pins

4. Use the values of real and apparent depth to determine the refractive index of water.
5. Present your findings to the class.

### Example 6.6

The real depth of a pool of water is 6 m and the refractive index of water is 1.33. Calculate the apparent depth of the pool of water.

#### Solution

$$n_{\text{water}} = \frac{\text{real depth}}{\text{apparent depth}}$$

$$\therefore \text{apparent depth} = \frac{\text{real depth}}{n_{\text{water}}} = \frac{6.0}{1.33} = 4.5 \text{ m.}$$

### Example 6.7

The real thickness of a glass block is 12 cm and apparent thickness is 8 cm. Calculate the refractive index of glass.

#### Solution

$$n_{\text{glass}} = \frac{\text{real depth}}{\text{apparent depth}} = \frac{12}{8} = 1.5$$

### Example 6.8

The graph in Fig. 6.18 shows the results obtained when a pin was viewed through different sizes of glass of same material.

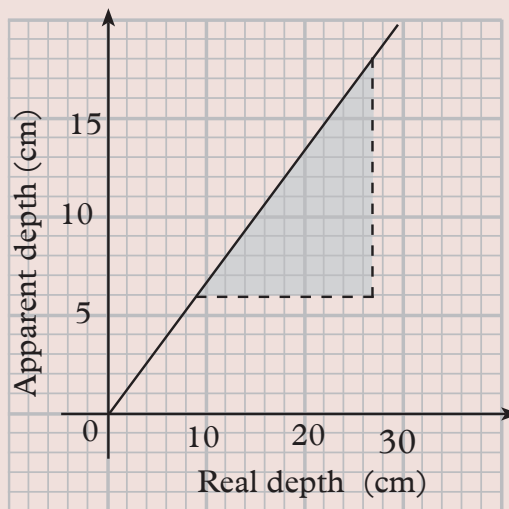

Fig. 6.18: A graph of apparent depth against real depth

Calculate the:

- (a) gradient of the graph.
- (b) refractive index of the glass.

**Solution**

(a) The gradient of the line =  $\frac{\text{apparent depth}}{\text{real depth}} = \frac{18 - 6}{27 - 9} = \frac{2}{3}$

(b) Refractive index,  $n = \frac{\text{real depth}}{\text{apparent depth}}$

$$n = \frac{1}{\text{gradient}} = \frac{1}{\frac{2}{3}} = \frac{3}{2} = 1.5$$

**Exercise 6.3**

- 1. In Fig. 6.19, the eye can see point P inside an empty cup, but not the coin inside. Suggest a simple method by which the observer can see the coin without moving the position of the eye, the coin or the cup.

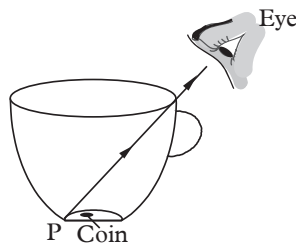

Fig. 6.19: Empty cup

- 2. The length of a glass block is 6 cm (Fig. 6.20). Using a ray diagram, show how the eye can see the virtual image of object O, if the refractive index of glass is 1.50.

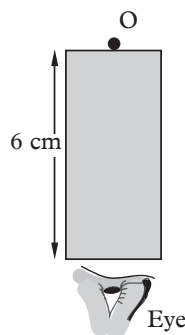

Fig. 6.20: Glass block

3. Describe an experiment to determine the refractive index of a glass block using two pins.
4. In a transparent liquid container, an air bubble appears to be 12 cm when viewed from one side and 18 cm when viewed from the other side (Fig. 6.21). Where exactly is the air bubble, if the length of the tank is 40 cm?

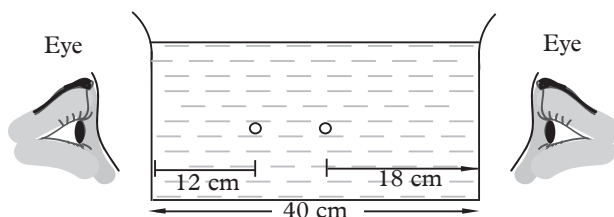

Fig. 6.21: Transparent liquid container

5. The graph in Fig. 6.22 shows the real depth against the apparent depth of a swimming pool as water is being filled.

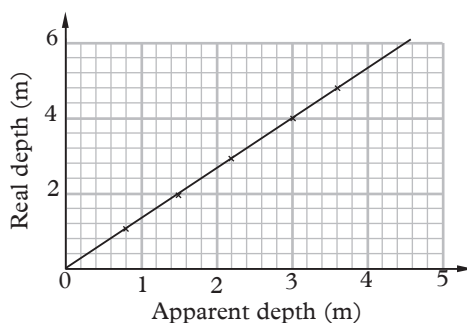

Fig. 6.22: A graph of real depth (m) against apparent depth (m)

- (a) Use the graph to calculate the refractive index of water.
- (b) Which physical property of light changes as light leaves the pool of water?
6. Describe an experiment to determine the refractive index of water.
7. Copy and complete a ray diagram to show how the eye sees the image of the dipped part of the pencil (Fig. 6.23). (Refractive index of water is 1.33).

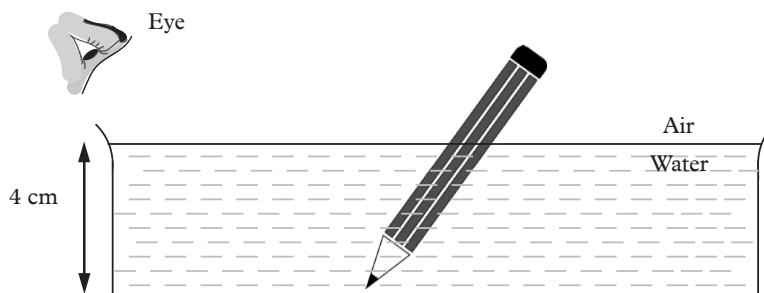

Fig. 6.23: Pencil dipped in water



8. A pool of water seems to be shallower than the real depth whereas the apparent height of a star in the sky is more than the real height. Explain this observation.

### 6.1.7 Critical angle and total internal reflection

For light to refract from a more optical dense to a less optical dense medium, the light ray must be incident at an angle less than a certain angle. The following activity will help us to determine this angle.

#### Activity 6.8

#### To investigate the critical angle and total internal reflection

##### Materials

- Table
- Ray box
- Protractor
- Paper protractor
- Semi circular glass block

##### Steps

1. Fix a thin circular 'paper protractor' calibrated in degrees on the table top.
2. Place a semicircular glass block such that the edge AB coincides with the  $90^\circ$ – $90^\circ$  mark of the protractor ensure the midpoint of the line AB is at Q (Fig. 6.24 (a)). The line along  $0^\circ$ – $0^\circ$  mark represents the normal NQM at Q.
3. In a dark room, use a ray box to pass a ray of light through the glass block at an angle of incidence ( $i$ ) say  $20^\circ$  (Fig. 6.24 (a)). Observe the path of the ray CQ in glass and ray QR in air, for the incident ray PC.

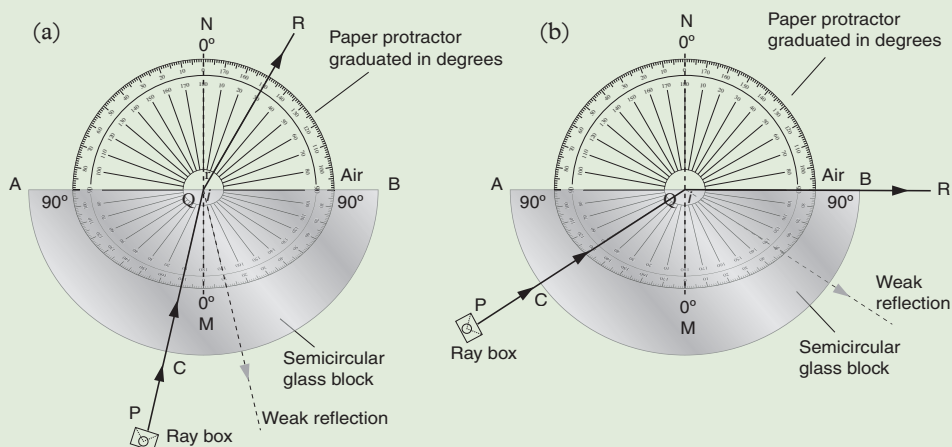

Fig. 6.24: Critical angle.

4. Increase the angle of incidence,  $i$ , gradually and observe the relative change in the path of the refracted ray in air. Explain your observation.

At C the ray strikes the glass block at an angle of  $90^\circ$  and is therefore not deviated inside the glass along QC. At Q, the refracted ray in air moves away from the normal and the angle of refraction,  $r$ , in air is greater than the angle of incidence,  $i$ , inside the glass. As the angle of incidence increases, the ray is refracted further away from the normal until, at one angle, it falls along the edge AB of the semicircular glass block. At this angle, the refracted ray cannot be located on the air. This particular angle of incidence is called *critical angle*,  $c$ , (Fig. 6.25 (b)).

The critical angle *is the angle of incidence in a denser medium for which the angle of refraction is  $90^\circ$  in the rarer medium.*

When the angle of incidence is greater than the critical angle, there is no refraction and all the light is reflected back inside the denser medium. This phenomenon is known as *total internal reflection* (Fig. 6.25). The angle of reflection,  $r$ , is equal to the angle of incidence,  $i$ .

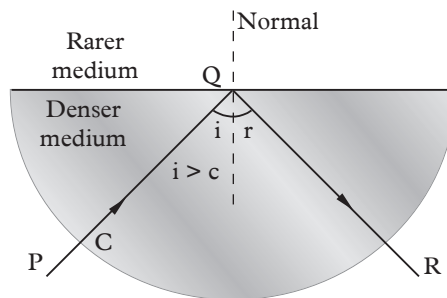

Fig. 6.25: Total internal reflection

The following conditions must be satisfied for total internal reflection to occur:

1. Light must travel from a denser medium to a less dense medium.
2. The angle of incidence in the denser medium must be greater than the critical angle.

### Refractive index using critical angle

Using Snell's law, the refractive index of glass-air boundary

$${}_g n_a = \frac{\sin i}{\sin r}$$

But if  $i = c$ ,  $r = 90^\circ$  and principle of reversibility (see Fig. 6.11).

$$\therefore n_g = \frac{\sin 90^\circ}{\sin c} = \frac{1}{\sin c}$$

Hence, refractive index of a medium  $n_g = \frac{1}{\sin c}$  where  $c$  is the critical angle.

### Example 6.9

Calculate the critical angle for glass-air interface, if the refractive index of glass is 1.50.

#### Solution

$$n_{\text{glass}} = \frac{1}{\sin c}$$

$$\sin c = \frac{1}{n_g} = \frac{1}{1.50} = 0.667$$

$$c = \sin^{-1} 0.667 = 41.8^\circ$$

### Example 6.10

Calculate the critical angle at the water-air interface if the refractive index of water is 1.33

#### Solution

$$n_w = \frac{1}{\sin c}$$

$$\sin c = \frac{1}{n_w} = \frac{1}{1.33} = 0.752$$

$$c = \sin^{-1} 0.667 = 48.8^\circ$$

### Example 6.11

Calculate the refractive index of diamond, if the critical angle for the diamond is  $24^\circ$ .

#### Solution

$$n_D = \frac{1}{\sin c} = \frac{1}{\sin 24^\circ} = \frac{1}{0.407} = 2.46$$

$\therefore$  Refractive index of diamond is 2.46

## 6.2 Refraction of light through a prism

### 6.2.1 Demonstration of refraction of light through a prism

#### Activity 6.9

#### To show refraction of light through a prism

##### Materials

- A glass prism
- White plain paper

##### Steps

1. Place a glass prism with plane ABEF resting on a white paper.

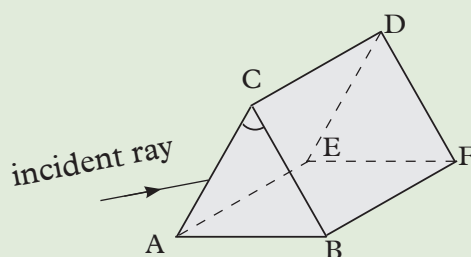

Fig. 6.26

2. Incident a ray of light on the edge CA.
3. What happens to the ray of light as it enters and leaves the glass prism?
4. Compare its behaviour between when it enters and leaves a rectangular glass block.

In a parallel glass block the first refraction cancels the second refraction. Hence, the incident ray and emergent ray are parallel. In the case of a glass prism, the second refraction adds to the first refraction. This is the importance of a prism. It can be used to analyse the components of white light.

A prism has a refracting medium bound by two plane surfaces inclined to each other at an angle. The two planes are the *refracting faces* ( $ADEC$  and  $ADFB$  in Fig. 6.27 (a)) and the angle between the faces is called the *angle of the prism* ( $\angle CAB$  in Fig. 6.27 (a)). The line along which the two faces meet is the *refracting edge* of the prism. The face opposite to the angle of the prism is called the *base of the prism* (Fig. 6.26 (a)). The section of the prism cut by a plane perpendicular to the edge of the prism is the *principal section* of the prism Fig. 6.27 (b) )

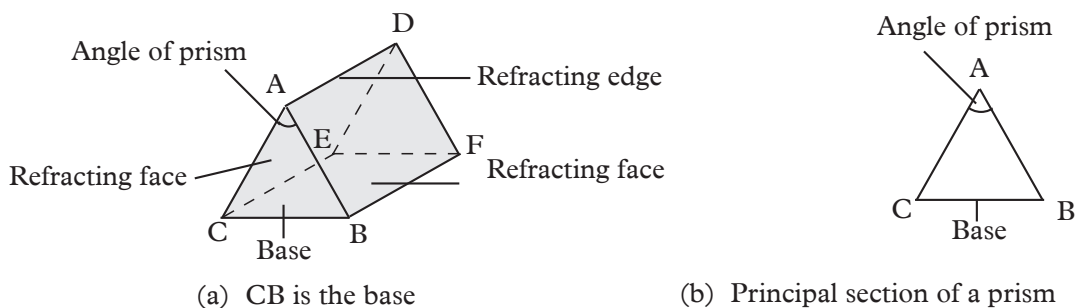

Fig. 6.27: Glass prism

When light passes from air into the triangular glass prism (ray PQ), it undergoes refraction. The refracted ray QR inside the glass bends towards the normal  $N_1N_2$ . The emergent ray RS bends away from the normal  $N_3N_4$  (Fig. 6.28). Ray PQ produced meets ray RS produced backwards at T. Notice that, the incident ray has *deviated* from its original direction. Angle VTR is called the *angle of deviation*. Hence the action of a prism is to *deviate light rays*.

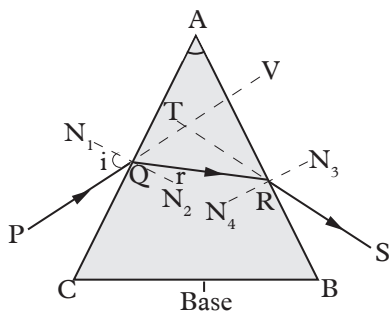

Fig. 6.28: Refraction of light through a prism

## 6.2.2 Dispersion of white light by a prism

### Activity 6.10

#### To illustrate dispersion of white light

#### Materials

- Triangular prism
- Ray of white light
- White screen

#### Steps

1. A narrow beam of white light (such as sunlight, light from carbon arc lamp or a mercury vapour lamp) from a narrow slit, in a semi-dark room, to an equilateral glass prism. Why do you think its necessary to use a narrow beam of white light?
2. Adjust the angle of incidence until a distinct band of colours is obtained on a white screen placed on the other side of the prism as shown in Fig. 6.29.

Why is it possible to obtain a band of different white colours of light from white light?

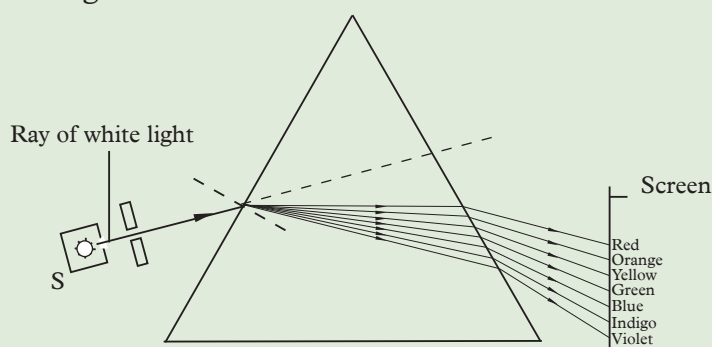

Fig. 6.29: Dispersion of white light forming a spectrum of colours

3. What colours are obtained on the white screen? How many of the colours can you identify? Is the angle of deviation the same for each colour? Explain why the different colours refract to different degrees.

A *monochromatic light* is one that has a *single colour* and a *single frequency* or *single wavelength*. White light is not monochromatic because it is made up of seven different colours. Non-monochromatic light is also called *composite light*.

When white light is passed through a triangular prism, it is split up into a series of colours as it enters the glass prism. Different colours are deviated to different angles. The colours are *red, orange, yellow, green, blue, indigo and violet*. These colours gradually blend into one another.

The above experiment was first carried out by Sir Isaac Newton. He noticed that *violet light is the most deviated colour* while *red light is the least deviated colour*. The splitting of white light into its constituent colours is called *dispersion*. The coloured band produced is called *visible spectrum* (Fig. 6.29).

For the same angle of incidence, each colour inside the glass prism has its own angle of refraction and angle of deviation. Since refractive index is given by  $n = \frac{\sin i}{\sin r}$ , it follows that each colour has its own refractive index for glass. But refractive index is also given by  $n = \frac{\text{speed of light in air}}{\text{speed of light in glass}}$ .

Therefore each colour travels with its own speed inside glass. For example, violet light having the least angle of refraction has the greatest refractive index for glass. This means that the speed of violet light is the least in glass.

If two identical prisms are placed as shown in the Fig. 6.30, the final spectrum produced is more spread out. This means that the angle of deviation of each colour is increased.

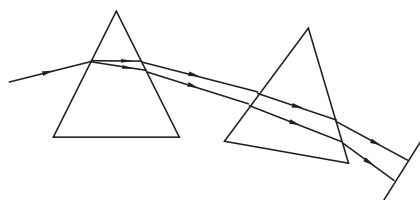

Fig. 6.30: More spread out spectrum.

### 6.2.3 Combination of spectrum colours

The dispersion created by one prism can be *reversed* by a second prism (Fig. 6.31). When reversed, a white light parallel to the incident white light emerges from the second prism.

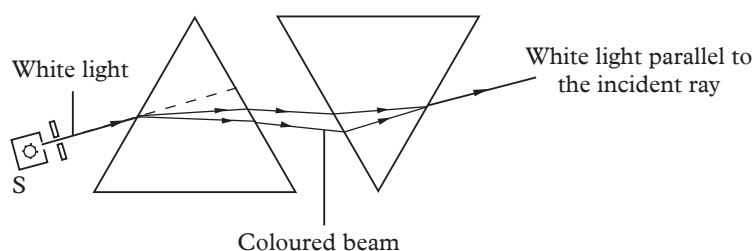

Fig. 6.31: Separation and combination of colours by prisms

### Exercise 6.4

- (a) Define critical angle.

(b) Write down the relationship between the critical angle and the refractive index of a medium.
- State the two conditions under which total internal reflection occurs.
- Calculate the value of critical angle for a liquid-air interface, if the refractive index of the liquid is 1.40.
- Copy and complete Fig. 6.32 to show the path of a ray of light through the glass prism. Mark the angle of incidence and the angle of deviation in your diagram
- Distinguish between monochromatic and composite light. Give an example of each.
- What do you understand by the terms deviation and dispersion.
- Write down the colours in a visible spectrum in the decreasing order of angle of deviation.

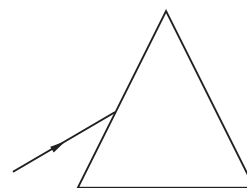

Fig. 6.32: Separation and combination of colours by prisms

8. Fig. 6.33 shows the path of a ray of white light incident on a glass prism.

(a) What name is given to the spreading out of white light inside the prism?

(b) What name is given to the band of colours seen on the screen?

(c) Name two physical properties which change for all the colours when they enter the prism.

(d) Mark the position of violet, blue and red light as seen on the screen.

9. Describe an experiment to illustrate the dispersion of white light.

10. A beam of light made of a mixture of red and green light is shone through a prism (Fig. 6.34).

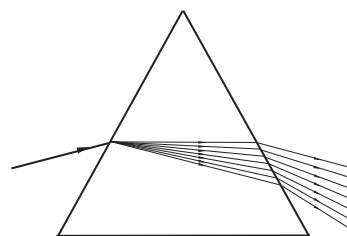

Fig. 6.33

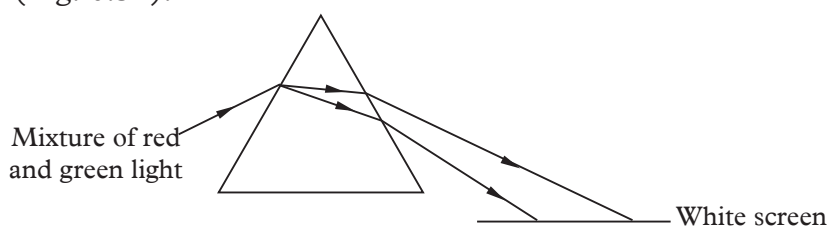

Fig. 6.34

(a) What name is given to the 'bending' of light as it enters the glass prism?

(b) Why does light 'bend' as it enters glass prism?

(c) Why do the two colours of light bend by different amount inside the prism?

(d) Which colour 'bends' the least?

#### 6.2.4 Total internal reflection of light by a prism

Under certain circumstance total internal reflection can occur in a prism. The following activity will demonstrate this.

##### Activity 6.11

##### To show total internal reflection by a prism

##### Materials

- Right-angled prism, white plain paper
- Mathematical set

##### Steps

1. Place a right-angled prism on a white paper.



2. Direct a ray (ray 1) towards side AB at a large angle of incidence say  $60^\circ$ . Trace the outline of the prism and record the angle of incidence on the side AB.
3. Repeat with (ray 2) less than  $60^\circ$  this time say  $40^\circ$ .
4. Continue decreasing the angle until the angle of incidence is zero (ray 3). What happens to the angle of incidence on AB?
5. What do you think leads to the observation you have made?

The angle is seen to increase up to the critical angles of glass (i.e.  $42^\circ$ ). Refraction stops and reflection occurs. (See Fig. 6.35)

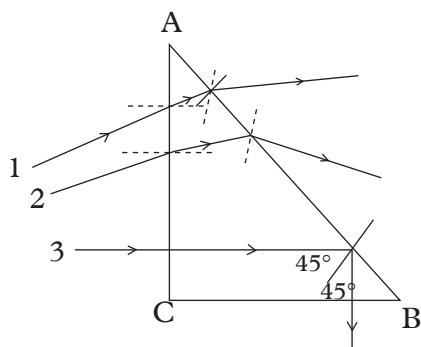

Fig. 6.35

For ray 3, the angle of incidence ( $45^\circ$ ) on the side AB is greater than the critical angle hence total internal reflection occurs and the ray emerges perpendicular to the other smaller side CB.

### Example 6.12

Copy and complete Fig. 6.36 to show the path of light PQ as it enters the right angled isosceles prism of refractive index 1.50.

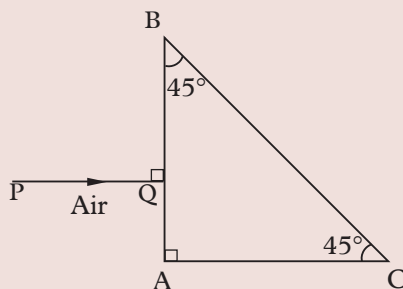

Fig. 6.36: Isosceles prism

### Solution

Critical angle  $c$  for glass-air interface is given by

Critical angle  $c$  for glass-air interface.

$$\sin c = \frac{1}{n_{\text{glass}}} = \frac{1}{1.5} = 0.667$$

$$c = 41.8^\circ$$

At the surface AB, the ray passes undeviated along QR in glass. At the surface BC, the angle of incidence,  $i = 45^\circ$ , since  $\angle BRQ = \angle BCA = 45^\circ$  (corresponding angles),  $r = 90^\circ - 45^\circ = 45^\circ$ . Since  $i$  is greater than the critical angle  $c$ , total internal reflection occurs (ray RS). Ray RS proceeds undeviated as ST in air (Fig. 6.37).

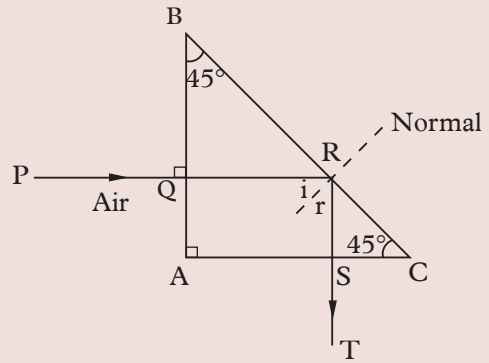

Fig. 6.37: Total internal reflection in isosceles prism

### Example 6.13

A ray of light passes from a liquid to air. Calculate the critical angle for the liquid-air interface, if the velocity of light in the liquid is  $2.4 \times 10^8$  m/s, while in air is  $3.0 \times 10^8$  m/s.

#### Solution

$$\text{Refractive index of a liquid} = \frac{\text{velocity of light in air}}{\text{velocity of light in liquid}}$$

$$= \frac{3 \times 10^8}{2.4 \times 10^8} = 1.25$$

$$n_{\text{medium}} = \frac{1}{\sin c} \quad \sin c = \frac{1}{n_{\text{medium}}} = \frac{1}{1.25} = 0.80$$

$$c = 53.1^\circ$$

The critical angle for the liquid is  $53.1^\circ$ .

## 6.2.5 Application of total internal reflection of light

### Activity 6.12

To describe the application of total internal reflection of light by a prism

#### Materials

- Right-angled prism
- white plain paper
- Mathematical set

#### Steps

1. Incident two rays of light as shown in Fig 6.38(a). The two rays emerge on

side CD.

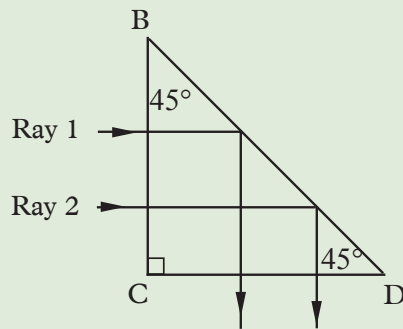

Fig. 6.38 (a)

2. Hold a blue glass plate (filter) in front of ray 1. The ray 1 is hereby coloured blue (Fig 6.38(b)).
3. Turn the prism as shown in fig 6.38(b) The blue ray enters as upper ray, but emerges as lower ray. Why is this possible?

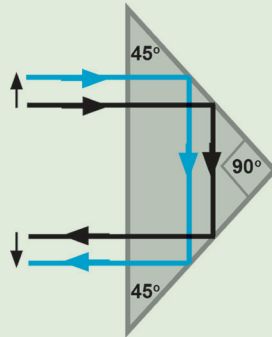

Fig. 6.38 (b)

This shows that a right-angled prism can therefore be used to reverse an image laterally. The following are some of the applications of total internal reflection of light in prism.

### 1. Totally reflecting prism

Right angled isosceles prisms deviate light rays through an angle of  $90^\circ$  (Fig. 6.38).

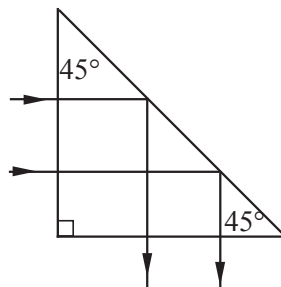

Fig. 6.39: Action of isosceles prisms

Reflecting prisms have more advantages than plane mirrors. Since plane mirrors are silvered at the back surface of a thick glass plate, they give rise to a number of *faint* images besides the *main* image. They also lose light intensity due to the refraction in glass. In the case of reflecting prisms, the light is totally reflected without much loss of intensity. They do not have invisible faint images found in mirrors. The silvering of the mirror may wear off with time whereas a prism has a tough structure. Due to these advantages, reflecting prisms are preferred in optical instrument such as periscopes, binoculars and camera.

## 2. Prism periscope

A periscope is a device which enables us to see over the top of an obstacle. Two right angled isosceles prism are used in *prism periscope* instead of the two plane mirrors used in a *simple periscope*. This periscope produces brighter images than those formed by plane mirrors.

A parallel beam of light normally incident on the first prism is turned through  $90^\circ$  and proceeds to the second prism and is again turned through  $90^\circ$  to reach the eye of a person. The final image produced is virtual and upright (Fig. 6.40).

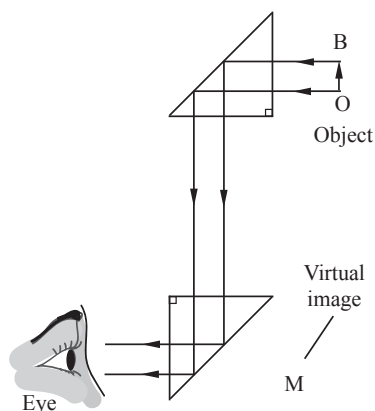

Fig. 6.40: Action of a prism periscope

The periscope of this type is normally used in submarines to sight enemy ships over the surface of the sea.

## 3. Optical fibres

An optical fibre is a long clear glass rod which can be of thickness of a fraction of a millimeter. When a ray of light enters the fibre, the angle of incidence,  $i$ , inside the glass is always greater than the critical angle  $c$  for glass-air interface and hence undergoes total internal reflection repeatedly on the boundary of glass fibre and air (Fig. 6.40). Light travels along the length of an optical fibre without much loss of light intensity.

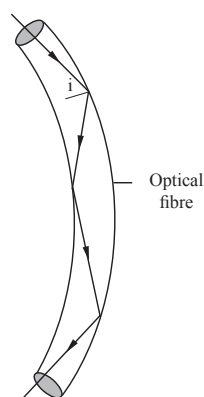

Fig. 6.41: Passage of light through an optical fibre

Optical fibres are used in transmitting signals in communication. In medicine, bundles of very fine flexible fibres are used to view the internal parts of a human body using an instrument called the *endoscope*.

#### 4. Rainbow

White light from the sun undergoes dispersion as it enters into the raindrops of water in the sky. Total internal reflection takes place at the opposite side of the raindrop and different colours emerge from the raindrop after refraction (Fig. 6.42).

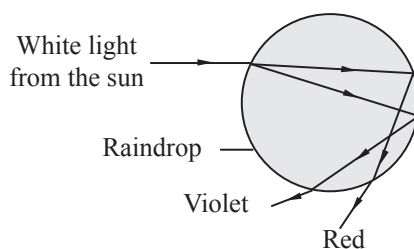

Fig. 6.42: A single raindrop produces a spectrum

#### 5. Mirage

The mirage is an *optical illusion* that takes place in a hot desert or a hot road due to total internal reflection. A traveller sees in the distance a *shimmering pool of water* in which the surrounding objects, like a tree, appear inverted (Fig. 6.43).

Light travelling from a denser medium (warm air) towards the earth, enters regions of rarer medium (very hot air of low density in contact with the earth) and undergoes total internal reflection at a certain point when the angle of incidence is greater than the critical angle. An observer on a distance sees the inverted image

of the tree. Further, as hot air in contact with the earth rises up due to convection currents, the image appears shimmering.

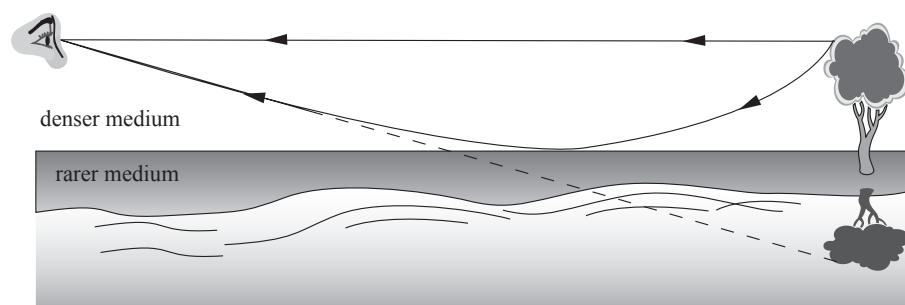

Fig. 6.43: Mirage

### Exercise 6.5

1. Certain prism may be used in such a way that refraction takes place when light passes through it. Draw a diagram of a prism acting in this way and deviating a ray of light through  $90^\circ$ .
2. A ray of light strikes a prism as shown in Fig. 6.44. Copy and complete the diagram to show the path followed by the ray as it passes through and out of the prism.

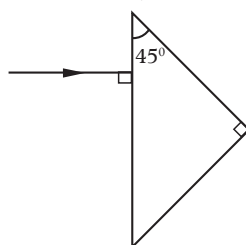

Fig. 6.44: Triangular prism

3. (a) Draw a diagram to show how two right angled isosceles prisms can be used in a periscope.  
(b) State a reason why glass prisms are preferred to plane mirrors for use in periscopes.
4. The critical angle for a glass-air interface is  $42^\circ$ . Copy and complete Fig. 6.45 to show the path of PQ and RQ, when they leave the glass block.

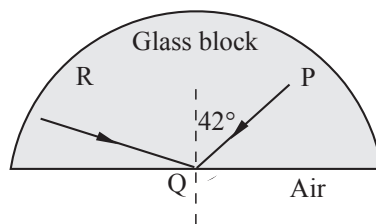

Fig. 6.45: Glass block

5. A narrow beam of light is incident on the face PQ of a glass prism of refractive index 1.50, as shown in Fig. 6.46.

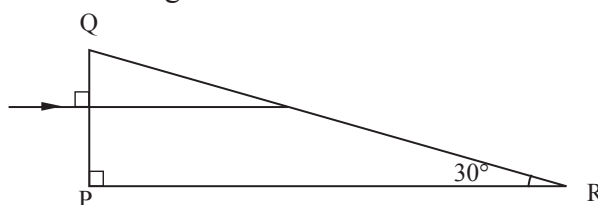

Fig. 6.46: Glass prism

- What is the angle of incidence at the face QR of the prism?
  - Copy and complete the diagram to show the path of light.
  - Why does the beam not change direction as it passes through the face PQ?
  - Give one change in property that occurs to the light when it passes through the face PQ.
6. Fig. 6.47 shows the path of a ray of light passing through a length of an optical fibre. Explain why the ray of light (a) does not change direction at B or at E (b) is totally reflected at C and D.

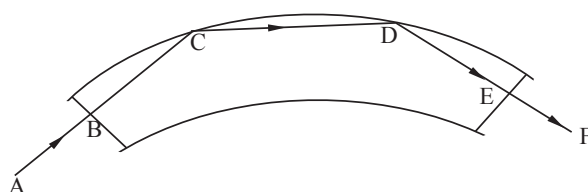

Fig. 6.47: Optical fibre

## Topic summary

- Refraction of light is the bending of light as it passes from one medium to another.
- Refraction of light takes place as the velocity of light is different in different media.
- Laws of refraction of light states that:
  1. The incident ray, the refracted ray and the normal to the surface at the point of the incidence are all in the same plane.
  2. The ratio of the sine of the angle of incidence to the sine of the angle of refraction is a constant for a given pair of media (this law is also known as Snell's law).

- According to Snell's law,  $\frac{\sin i}{\sin r} = \mu$  is a constant known as the refractive index of the medium with respect to air, when the incident ray is in air.

- Refractive index of a medium ( $\mu$ ) is defined as

$$\mu = \frac{\text{velocity of light in air}}{\text{velocity of light in a medium}}$$

- A pool of water appears to be shallower than the real depth, due to refraction of light.

$$\text{Refractive index of a medium} = \frac{\text{real depth}}{\text{apparent depth}}$$

- As the angle of incidence increases in a denser medium, the angle of refraction also increases in the rarer medium. Critical angle is the angle of incidence in the denser medium for which the angle of refraction is  $90^\circ$  in the rarer medium.

$$\mu_{\text{medium}} = \frac{1}{\sin c}$$

- Total internal reflection occurs when the angle of incidence in the denser medium is greater than the critical angle.
- Prism periscopes, prism binoculars, optic fibres etc., apply the properties of total internal reflection in their construction. Formation of a rainbow is due to dispersion and total internal reflection.
- A glass prism deviates a monochromatic light from its original path and the light bends towards the base of the prism.
- There is deviation as well as dispersion when white light is incident on a glass prism.
- Dispersion is the separation of white light into its component colours.

A lens is a transparent medium bound between two surfaces of definite geometrical shape.

## Topic Test 6

For questions 1 - 6, select the correct response from the choices given.

1. Bending of light is called

- |                     |                        |
|---------------------|------------------------|
| <b>A</b> Reflection | <b>B</b> Dispersion    |
| <b>C</b> Refraction | <b>D</b> Incidence ray |





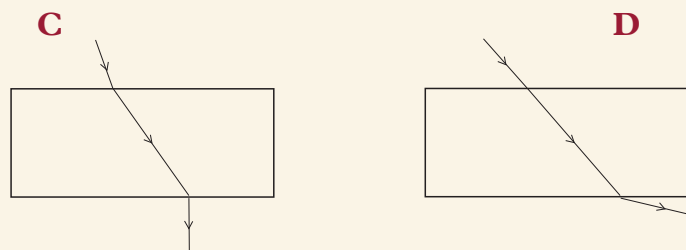

Fig. 6.48 (c) and (d): Rectangular glass block

7. Use the words provided to fill in the blank spaces.  
*spectrum, deviation, refraction, dispersion, velocity, composite, monochromatic, seven*  
 \_\_\_\_ is the bending of light when it travels from one medium to another. It takes place because the \_\_\_\_ of light is different in different media.
9. A beam of light is incident on a glass block as shown in Fig. 6.49. Copy and complete the diagram to show the path of the beam of light in glass after refraction.

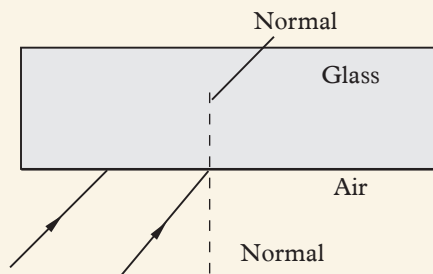

Fig. 6.49: Rectangular glass block

10. (a) Table 6.4 below gives the values of angle of incidence and angle of refraction when light passes from air into a plane glass surface. Calculate the mean refractive index of glass.

Table 6.4

$i^\circ$	$r^\circ$
25	17
40	26
70	40

- (b) The incomplete Table 6.5 shows the values of angle of incidence,  $i$ , and of angle of refraction,  $r$ , when light passes from *glass to air*.

Table 6.5

$i^\circ$	$r^\circ$
10	
30	46.5
40	

Calculate  $r$ , when  $i = 10^\circ$  and  $40^\circ$  and complete the table.

11. Calculate the refractive index of diamond if the velocity of light in air is  $3.0 \times 10^8$  m/s and that in diamond is  $1.25 \times 10^8$  m/s.
12. Fig. 6.50 shows a ray of light passing from air into oil. Calculate the angle of refraction in oil if the velocity of light in air is  $3.0 \times 10^8$  m/s and that in a transparent oil is  $2.2 \times 10^8$  m/s.

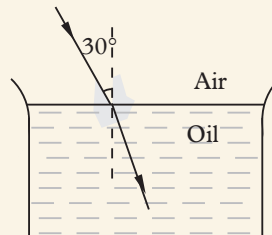

Fig. 6.50: Air-oil interface

13. In an attempt to determine the refractive index of a glass block, a learner finds the displacement produced due to refraction by glass as  $d$  and apparent thickness of the block as  $y$  (Fig. 6.51). Show that the refractive index of glass may be expressed as  $\nu = (1 + \frac{d}{y})$

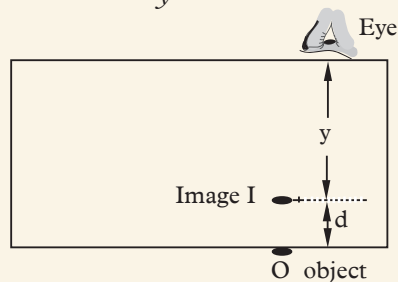

Fig. 6.51: Rectangular glass block

14. A learner attempted to find the refractive index of a liquid using a concave mirror and a pin. The radius of curvature of the mirror is 20 cm. When a small quantity of a liquid was placed in the mirror, the pin had to be moved down by 4 cm. Calculate the refractive index of the liquid.
15. The light ray passing from glass to air is monochromatic and has a frequency of  $4 \times 10^{14}$  Hz and a wavelength of  $5 \times 10^{-7}$  m in glass (Fig. 6.52).

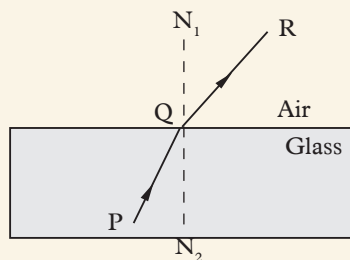

Fig. 6.52: Glass block

- (a) What is meant by monochromatic?
- (b) Calculate the velocity of light in glass.
- (c) Calculate the velocity of light in air. (Refractive index of glass is 1.50).

16. A single ray of light is incident on an equilateral glass prism as shown in the Fig. 6.53. Copy and complete the diagram to show the path of light through and out of the prism (refractive index of glass is 1.50).

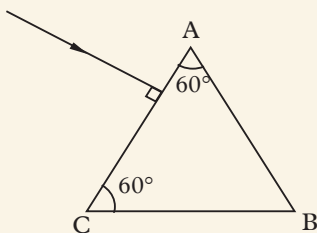

Fig. 6.53: Equilateral glass prism

17. Table 6.96 shows the reading of the angle of incidence and angle of refraction for a rectangular glass block.

Table 6.6

$i^\circ$	10	25	40	55	70	80
$r^\circ$	8	17	25	32	38	41

- (a) Draw a graph of  $\sin r$  (y-axis) against  $\sin i$  (x-axis).
  - (b) What can you conclude from the graph about the relationship between  $\sin i$  and  $\sin r$ ?
  - (c) Sketch another graph on the same axes in part (a), if a transparent substance of higher refractive index had been used instead of the glass block. Explain how you arrive at your answer.
18. Copy and complete the diagram in Fig. 6.54 to show the path of the ray through the prisms arranged as shown below.

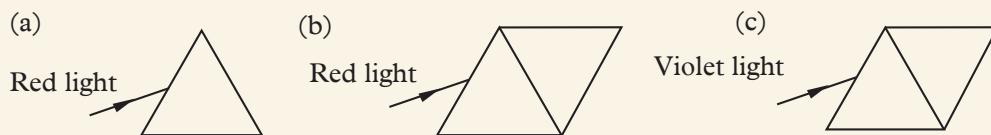

Fig. 6.54

- (a) a ray of red light is incident on the prism.
- (b) a ray of red light is incident on 2 identical prisms placed as shown.
- (c) the red light in (b) is replaced by violet light.

**Topics in the unit**

Topic 7: Introduction to static electricity

Topic 8: Introduction to current Electricity

**Learning outcomes****Knowledge and Understanding**

- Understand the concept of static electricity and of the flow of electricity around circuits.

**Skills**

- Researching using a range of sources
- Posing questions and predict what might happen
- Designing fair tests
- Use appropriate measures
- Collect and present results appropriately
- Interpret results accurately
- Report findings appropriately

**Attitudes**

- Be willing to predict based on prior learning.

**Key inquiry questions**

- Why is electricity classified into current electricity and static electricity?
- Why does an accumulator of a car have to be topped up with distilled water at frequent intervals?
- How would you protect your lead accumulator?
- How do you measure electric current?
- How can we differentiate between a dry cell and lead accumulator?

**Topic outline** >>>

- Types of electrostatic charge.
- Method of charging bodies.
- Insulators and conductors.
- Application of electrostatic charges.

**Introduction**

You may have observed the following phenomena:

1. Sometimes one can get a shock when getting out of a car or touching the metal knob of the door.
2. Dust particles stick to a window pane when the pane is wiped with a dry cloth on a dry day.

You might have also experienced crackles and sparks that accompany taking off clothes made of materials like nylon, polyester.

These and many more experiences are as a result of *electrostatic phenomena*. The physics behind these observations will be clear after going through this topic.

**7.1 Types of electrostatic charges****Activity 7.1**

**To observe the attraction between water particles and charged rod**

**Materials**

- A small stream of water
- A polythene strip or a comb
- A piece of paper

**Steps**

1. Take the polythene strip or the comb near to a stream of water flowing from a tap. Now bring the polythene strip close to the pieces of paper. Does the polythene strip attract the water stream or the pieces of paper? Why is this possible?

2. Now, rub the polythene strip or the comb against your hair or cloth.
3. Slowly bring the polythene strip or the comb near the water stream. What do you observe? Does it have the same effect when you bring it closer to the pieces of paper?
4. What do you think would happen if you rubbed a balloon on your clothes and brought it near the pieces of paper or a wall?
5. Now, brainstorm with your class members the different types of electrostatic charges.

Nothing happens when the comb is brought near the stream of water or pieces of paper without first rubbing it on hair or cloth. When rubbed through hair, and brought near the stream, the water bends towards the comb (Fig. 7.1).

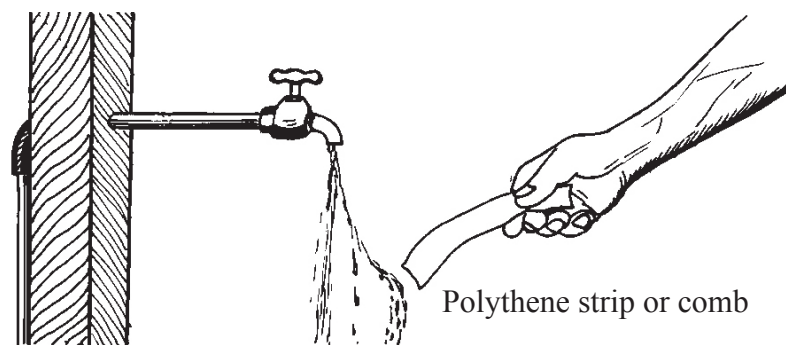

Fig. 7.1: Stream of water attracted to a polythene strip or comb

This happens because the water is attracted towards the charged polythene strip or comb.

When the polythene strip or the comb is rubbed against hair/cloth, it acquires the *attractive* property. The charged polythene strip *attracts* the thin stream of water.

The charged polythene strip or the comb can also attract bits of paper, tiny pieces of cloth, etc. Many substances such as glass, plastic, ebonite and perspex when rubbed with silk, rubber, fur, cotton wool or cat skin acquire the *attractive* property. The charges developed on the materials are at rest and cannot move. We therefore, call them *static charges*. The study of static charges is called *electrostatics*. There are two types of static charges: *positive charges* and *negative charges*. Scientists like Benjamin Franklin, and Charles Coulomb contributed a lot to the development of this branch of physics.

Therefore, a charge can be defined as a *characteristic of matter that express the extent to which it has more or fewer electrons than protons and vice versa.*

The SI unit of quantity of charge is the *coulomb (C)*, named after a famous scientist called *Charles Augustin de Coulomb (1736-1806)*.

## 7.2 The law of electrostatics

### Activity 7.2

#### To demonstrate types of charges

#### Materials

- Polythene rods
- Perspex rod
- Dry piece of woollen cloth
- Clamp and stand
- Thin thread

#### Steps

1. Charge the polythene rod by rubbing it against the woollen cloth. What charge do you think it acquires.
2. Suspend it by a thin thread from the clamp as shown in Fig. 7.2 (a).
3. Charge a second polythene rod in a similar way and bring it close to the suspended one as shown in Fig. 7.2 (b). What do you observe?
4. Repeat the procedure using polythene rod and perspex rod as shown in Fig. 7.2 (c).

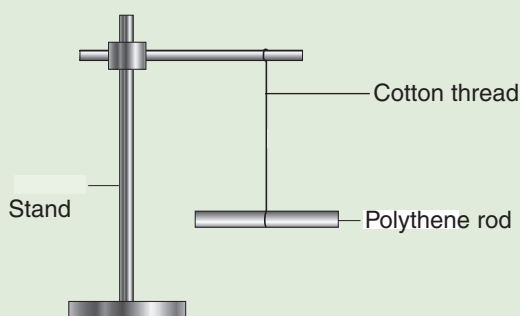

Fig. 7.2 (a): A suspended charged polythene rod.

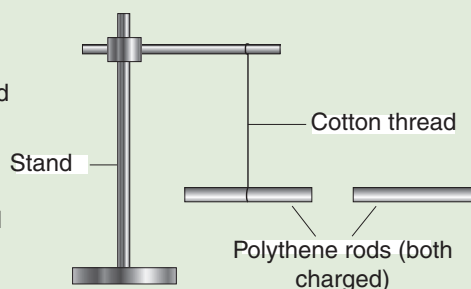

Fig. 7.2 (b): Two charged polythene rods brought close.



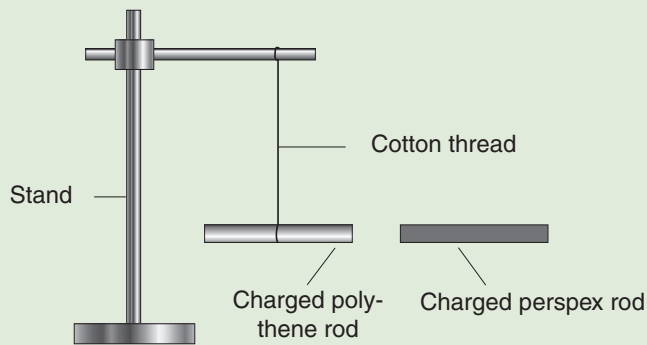

Fig. 7.2 (c): Charged polythene and perspex rods.

When the two charged polythene rods are brought close to each other they repel. When the charged perspex rod is brought close to the charged polythene rod, they attract.

Different substances acquire different charges during charging depending on the material they are made of. The rods were all rubbed using woollen cloth. The two polythene rods acquired the same electric charge and thus they repelled. The polythene rod and the perspex rod acquired different charges and thus they attracted.

### Activity 7.3

#### To investigate the electrostatic force between two charged rods

#### Materials

- An ebonite rod
- Polythene rod
- Silk
- Glass rod
- A thread

#### Steps

1. Rub an ebonite rod with silk and suspend the rod with a stirrup (support) and thread. What charge does the ebonite rod acquire?
2. Bring another charged ebonite rod to one end of the suspended rod. (Fig. 7.3) What do you observe? What do you think causes this observation?

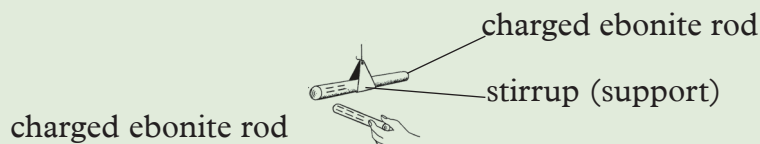

Fig. 7.3 Like charges repel

3. Now bring a charged polythene rod near one end of the ebonite rod and observe what happens. Does it have the same effect as in step 2?
4. Rub the glass rod on silk and suspend it with the strip. What charge does the glass rod acquire?
5. Bring another charged glass rod and ebonite rod respectively near the suspended glass rod. Note down what happens for each case.
6. Use the observation made in steps 2, 3 and 5 to complete table 7.1. Can you be able to state the law of charges from the data you have?

Charge on the rod			Result
+	+	Like charges	
-	-	Like charges	
+	-	Unlike charges	
-	+	Unlike charges	

Table 7.1

When ebonite rod is rubbed against silk it becomes negatively charged. When it is brought next to another charged ebonite rod, they repel. Consequently, when a polythene rod or glass rod is rubbed against silk it becomes positively charged. When two charged glass rods are brought close to each other they repel. However, it should be noted that when an ebonite rod (negatively charged) is brought near a glass rod (positively charged) they attract each other.

This leads us to the basic law of charges which states that **like charges repel while unlike charges attract**. The closer the materials are to each other, the greater the forces of attraction or repulsion.

### 7.3 Conductors and insulators

#### Activity 7.4

#### To confirm that a body is charged

(Work in groups)

#### Materials

- A metal sphere
- Cotton cloth
- Fingers
- Plastic strip
- Insulating stand
- Stand and clamp copper wire
- Paper strip
- Glass rod
- Stick
- Nail

## Steps

1. Suspend the glass rod with a string on the clamp. Charge the rod positively by rubbing it with the cloth.
2. Place the metal sphere on the insulating stand and charge it positively by rubbing it with the cloth.
3. Bring the metal sphere near the suspended charged glass rod and observe what happens to the rod (Fig 7.4 (a)). In what direction does the rod move? Why does it move?
4. Move the metal sphere away from the rod. Touch the surface of the sphere with your bare fingers and bring it back near the suspended rod Fig 7.4(b). What do you think happens when you touch the sphere with your fingers? What observation do you make when you bring it back near the suspended rod? Does the rod move? Explain your observation.

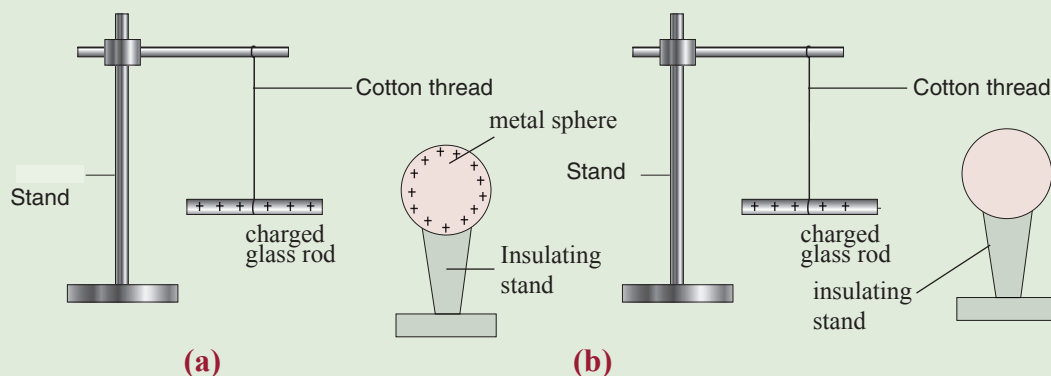

Fig. 7.4: Identifying conductors and insulators

5. Repeat steps 1 to 4 several times, each time holding a different material (copper wire, stick, papers tick and so on), near surface of the charged metal sphere. Note down the observation in each case.
6. Group the materials that lead to the same observation. How many categories of materials do you get? Suggest the names of the categories. Why do the different materials lead to different observation?
7. Compare your observations with other groups in your class.

In Activity 7.4, you should have observed that the positively charged metal sphere repelled the suspended positively charged glass rod before being touched with any of the materials. When the charged sphere was touched with the hand negative charges moved from the ground through your body and finger to the sphere neutralizing it. Therefore, the sphere could not repel the suspended rod. This shows that the human body is a good conductor of charge.

Similarly, when the charged sphere was touched with the copper wire, and nail, it also got discharged and could not repel the suspended rod. This shows that the copper wire, and nail are good conductors of charge.

However, when the charged sphere was touched with the stick, paper strip and plastic strip, it still repelled the suspended rod meaning that it was not discharged. This shows that negative charges were not able to flow through these materials to the metal sphere. Thus, the stick, paper strip and plastic strip are insulators. Let us now discuss conductors and insulators in details.

### Conductors

These are materials which allow the flow of charges through them. They are made of atoms whose outer electrons in the atoms loosely bound and free to move through the material. Some examples include; *copper, aluminium, gold, silver, water, aqueous solutions of salts and graphite. Human body, and living trees are also conductors.*

If a charged conductor is touched with another object, the conductor can transfer its charge to that object. The transfer of charge between objects occurs more readily if the second object is made of the same material as the conductor.

### Insulator

They are materials which do not allow free flow of electric charges from within them. Examples include most non-metals *glass, porcelain, plastic, dry air, paper, rubber, styrofoam, mica* and so on.

If charges are transferred to an insulator at a given location, the excess charges will remain at the initial location of charging.

Insulators play a critical role in real life. For example, conductors e.g electric cables are usually covered with insulators to protect us from electric shock.

## 7.4 Effects and applications of electrostatics

### Activity 7.5

#### To investigate real life effects of electrostatics

(Work in groups)

#### Materials

- Two mirrors
- A dry cloth
- Wet cloth
- Chalk dust

#### Steps

1. Rub the first mirror with a dry cloth for some time.
2. Rub the second mirror with a wet cloth.
3. Sprinkle both mirrors with very fine chalk dust and observe what happens to the particle.
4. Where does the dust/ chalk stick so much? Explain your observation.
5. Discuss with your partner some applications of electrostatics.

When the mirror is rubbed with a dry cloth, it gets charged by friction hence attracted the chalk dust particles. This is why most window glasses are usually dusty. The following are some other effects of electrostatics:

1. One gets a shock on touching the metal knob of the door of a car while getting out of the car. Electric charges build up on the surface of a car due to friction with the road as well as with the air molecules. When the metal knob is touched, charges flow from the knob to the earth through the person. The discharging of the charges on the surface of the car through the person gives a shock. If a metal chain is attached to the car on the outside, the charges can pass easily to the earth and the charges cannot build up.

It is for this reason that metal chains are attached to a petrol tanker. If large charges are allowed to *pile up* on the tanker, even a small spark produced can cause a fire and the tanker can explode.

2. When a mirror is cleaned with a dry cloth, both the mirror and the cloth get charged due to friction. The charged mirror acquires the attractive property. Dust, thin hair or fluffs can therefore stick to the mirror.
3. Cars are painted using a spray gun. The car is usually earthed and the paint droplets coming out of the spray gun are given a positive charge. The car attracts these charged droplets of paint uniformly.
4. Dust and smoke particles are extracted from the inside of the chimney by electrostatic attraction. This reduces the air pollution which is a health hazard.
5. Electrostatic induction is used in the photocopying machines.
6. Though rubber is an insulator, special materials called conductive rubber is used to make aeroplane tyres. The conductive rubber tyres reduce the risk of an explosion during refuelling the aircraft. When the metal sprout of the fuel pipe touches the petrol tank sparks can be produced leading to an explosion.

### Topic summary

- The study of static or stationary charges is called electrostatics.
- Some substances become charged easily with static electricity when rubbed with a suitable substance. Charging a substance by rubbing is also called charging by friction.
- A flash of lightning is one of nature's most spectacular phenomena. Lightning flashes are massive discharge of stationary electric charges that are produced when moving particles in clouds rub against each other.
- There are two types of charges namely positive charge and negative charge.
- The basic law of charges states that ***like charges repel while unlike charges attract.***

## Topic Test 7

1. Define electrostatics.
2. Name two types of charges.
3. State the basic law of charges.
4. Explain the following:
  - (a) If a glass window is polished vigorously, it will attract dust.
  - (b) When taking off a polyester shirt on a dry night it will give off some sparks.
5. Fig. 7.5 shows two polythene rods, X and Y. X is suspended on a stand using a cotton thread.

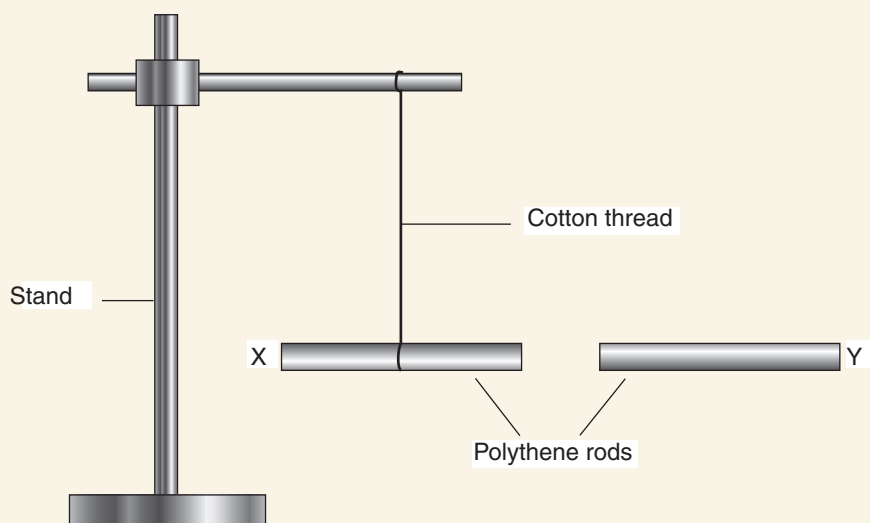

Fig. 7.5

- State and explain what would happen in each of the following cases.
- (a) X and Y are rubbed with clean dry woollen cloth.
  - (b) Y is replaced with a perspex rod and both are rubbed with a clean dry woollen cloth.
6. Describe an experiment to show that a charged body can attract an uncharged body.

# Introduction to current Electricity

## Topic Outline >>>

- Simple electric circuit and its components.
- Arrangement of bulbs and cells in an electric circuit.
- Electric current.
- Electric potential difference.
- Measurement of current and voltage.
- Ohm's law.
- Effect of electric current.
- Safety precautions to observe when handling electrical applications.

## Introduction

One of the most convenient types of energy is electrical energy. It has played a vital part in making our lives easier. We use electrical energy in lighting, heating and operating devices like television sets, radios, telephones, computers and electrical train. In this topic, we shall take a closer look at current electricity and find out its effects and safety precautions to be taken while using it.

### 8.1 Simple electric circuit and its components

#### Activity 8.1

#### To set up a simple electric circuit

#### Materials

- Switch
- Cell holder
- Dry cell
- Two connecting wires
- Bulb in a bulb holder

#### Steps

1. Place a dry cell in a cell holder.
2. Connect one end of the connecting wire to one of the terminals of the cell holder. Screw the bulb in the bulb holder.
3. Connect the other free end of the wire from the dry cell to the bulb holder (Fig. 8.1).

4. Use the second wire to connect the other end of the dry cell to the bulb through a switch (Fig. 8.1).

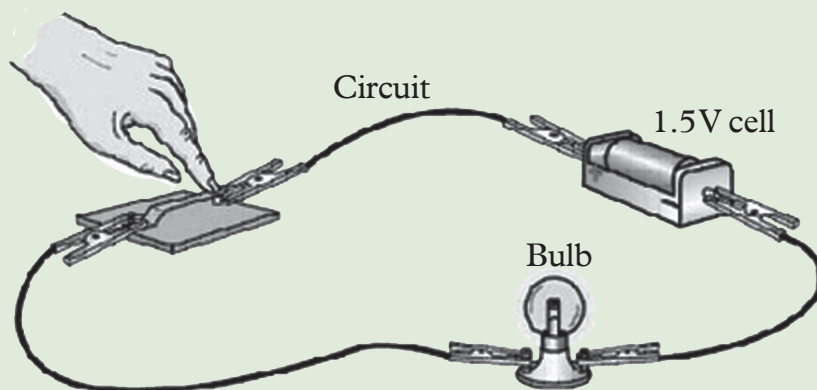

Fig. 8.1: A simple electric circuit diagram showing actual components

5. Close and open the switch in turn. What happens to the bulb? Explain your observation.
6. What do you think would happen if the connection on the dry cell was interchanged?

When the switch connected to a battery is closed, the bulb lights.

The cell provides electrical energy needed to light the bulb. The bulb converts electrical energy into light and heat energy. A cell is a kind of a 'pump' which provides electrical energy needed to drive charges along a complete path formed by the wire through the bulb switch and back again to the cell. This complete path along which the charges flow is called **electric circuit**.

When the switch is open, the bulb does not light. This is called an **open circuit**. When the bulb lights the circuit is called **closed circuit**.

### **Electric circuit components and their symbols**

In electric circuit diagrams, we represent the actual components with symbols. Table 8.1 shows some of the components, their symbols and definition that are used in electric circuit diagrams.



Name of component	Symbol	Definition
Cell		Small source of electric energy.
Battery		Large source of electric energy.
Power supply		D.C mains.
Open switch		Breaks the circuit.
Closed switch		Completes the circuits.
Wires joined		Junctions.
Connecting wires		Wires that joins two or more components in an electric circuit.
Lamp/bulb		Convert electric energy to heat and light.
Ammeter		Measures electric current.
Voltmeter		Measures potential difference (p.d) and voltage.

Table 8.1: Circuit components and their symbols

The simple electric circuit in Fig. 8.2 can be drawn using symbols as shown in Fig. 8.2.

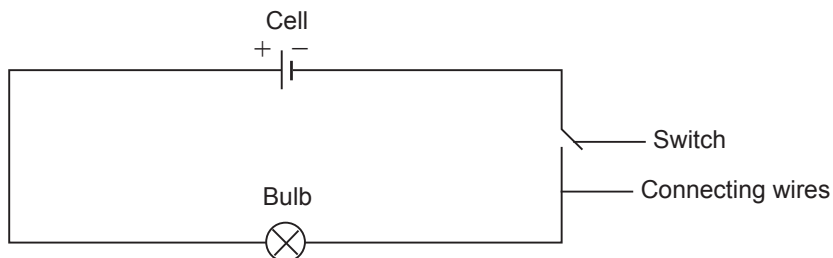

Fig. 8.2: Simple electric circuit diagram using symbols

## 8.2 Arrangement of bulbs and cells in an electric circuit

Bulbs and cells may be connected either in series or in parallel in electric circuits.

## 8.2.1 Bulbs in series

### Activity 8.2

#### To observe the brightness of two bulbs in series

#### Materials

- A switch
- Two identical 1.5V torch bulbs
- Connecting wire
- A 1.5V dry cell
- Cell holder

#### Steps

1. Connect the setup as shown in Fig. 8.3(a). Close the switch and note the brightness of the bulb.
2. Now connect the circuit with 2 identical bulbs as shown in Fig. 8.3(b). Close the switch and note the brightness of the bulbs.

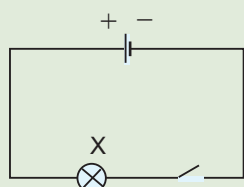

(a) One bulb connected

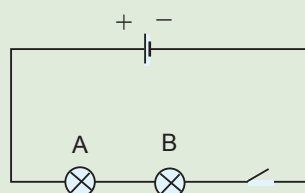

(b) Two bulbs connected

Fig. 8.3: Series connection

3. Repeat the experiment with the switch connected between the two bulbs and observe the brightness of the bulbs.
4. What is the observation on the brightness of the bulbs? Explain your answer.

Bulbs A and B are said to be connected in *series*. In this connection, the energy provided by the cell is shared equally between the two identical bulbs. Hence the bulbs are dimmer.

The same effect as when one bulb is connected is observed. Changing the position of the switch also has no effect on the brightness of the bulbs. The bulbs in series in the same circuit are dim.

## 8.2.2 Bulbs in parallel

### Activity 8.3

#### To observe the brightness of two bulbs in parallel

#### Materials

- A dry cell
- Three identical torch bulb
- Cell holder
- Connecting wires
- A switch

## Steps

1. Connect one circuit with one bulb as shown in Fig. 8.4(a) and another circuit with two bulbs as shown in Fig. 8.4(b).
2. Close the switches of the two circuits and compare the brightness of the two bulbs A and B in Fig. 8.4 (b) with the brightness of bulb X in Fig. 8.4(a). Explain your observation.

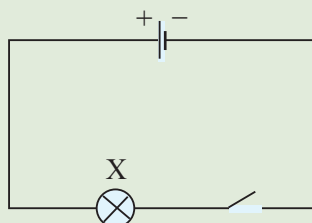

(a) One bulb connected

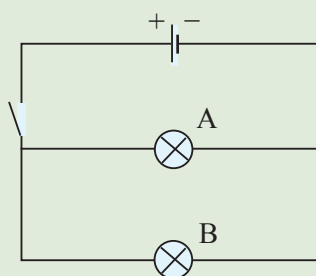

(b) Two bulbs connected

Fig.8.4: Parallel connection

3. What do you think would happen if more bulbs were added to the circuit?

All the three bulbs have the same brightness. The bulbs in Fig. 8.4(b) are said to be connected in *parallel*. In this connection, the same energy from the cell is provided to each of the two bulbs and hence the brightness of bulb A and bulb B is the same as the brightness of bulb X.

Bulbs in parallel in the same circuit have equal brightness.

## 8.2.3 Cells in series

### Activity 8.4

To observe the brightness of a bulb with two cells in series

#### Materials

- Three identical dry cells
- Two 1.5V torch bulb
- Connecting wires
- Two switches
- Cell holder

## Steps

1. Set up two circuit diagrams as shown in Fig. 8.5(a). In Fig. 8.5(b), connect two cells in series.

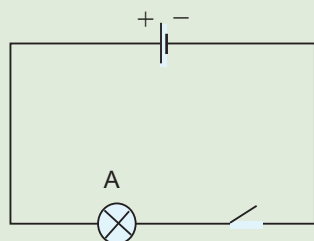

(a) One cell

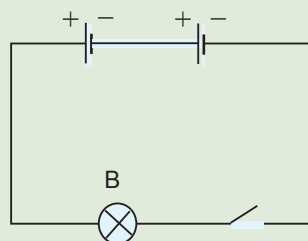

(b) Two cells in series

Fig. 8.5: Cells in series

2. Close the switches and compare the brightness of bulb A and B. The brightness of bulb B is more than the brightness of bulb A.
3. Explain what observation would be made if more cells were added to the circuit.

The energy provided by cells in series is *more* than energy from one cell. Cells in series in the same circuit increases the energy supplied.

## 8.2.4 Cells in parallel

### Activity 8.5

To investigate the brightness of bulbs with two cells in parallel

#### Materials

- Three identical dry cells
- Two switches
- Cell holder
- Two identical bulbs
- Connecting wires

#### Steps

1. Modify the connection in Activity 8.4 to have the cells in parallel.
2. Write down the procedure with a well labelled diagram of the circuit you have connected.
3. What observation do you make on the brightness of the bulb?

When cells are connected in parallel, the energy they provide does not change. It is the same as using only one cell.

Number of cells in parallel does not have any effect on energy supplied.

### Exercise 8.1

- Using suitable circuit diagram, explain the term parallel and series connection.
- You have been provided with a torch cell, two switches, two torch bulbs and connecting wires. Draw a possible circuit diagram that would allow the two bulbs to be switched on independently.
- You have been provided with the following electrical components; two dry cells, three bulbs, a switch and connecting wires. Draw a circuit diagram using:

(a) two bulbs in series with one cell.

(b) one bulb in series and two bulbs in parallel with one cell.

In each case show the position of the switch for all the bulbs to light at same time.

- Fig. 8.6 shows some circuit diagrams. Which of the diagrams are:

(i) series circuit

(ii) parallel circuit

(iii) incomplete circuit

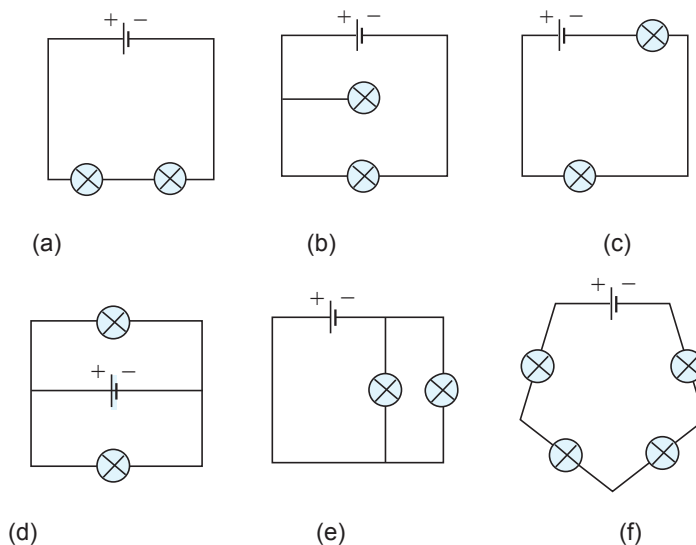

Fig. 8.6

5. Three identical bulbs are connected as shown in Fig. 8.7. Compare the brightness of the bulbs B and C with the brightness of bulb A when:
- (a) the switch is open,                      (b) the switch is closed.
- Explain your answer in (a) and (b).

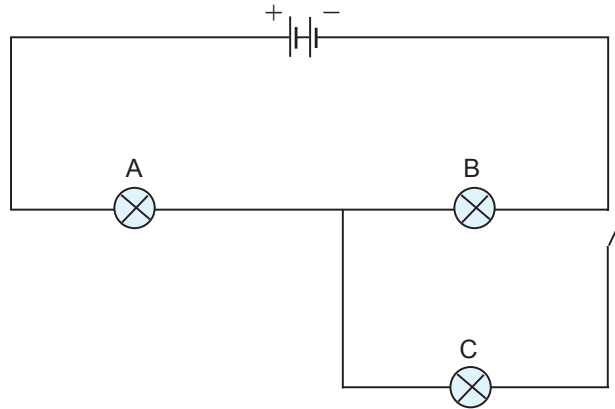

Fig. 8.7

6. Use the two circuits shown in Fig. 8.8 (a) and (b) to complete Table 8.2.

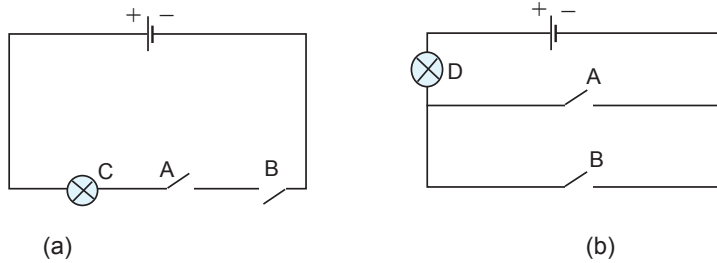

Fig. 8.8: Simple electric circuits

Table 8.2

Switch A	Switch B	Bulb C	Bulb D
Open	Open		
Open	Close		
Close		Off	
	Close	On	

7. Two identical bulbs, A and B are connected as shown in Fig. 8.9. Switches  $S_1$  and  $S_2$  are used to control the bulbs. Copy and complete Table 8.3.

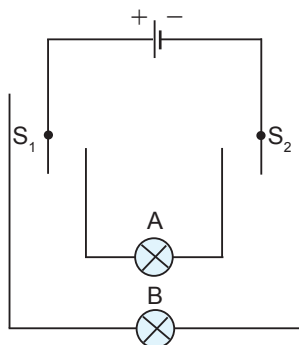

Fig. 8.9: A simple circuit

Table 8.3

Position of $S_1$	Position of $S_2$	Bulb A	Bulb B
Left	Left	OFF	
Left	Right		
Right	Left	ON	
Right	Right		

8. Draw a circuit diagram to show how 3 lamps can be connected to a cell so that 2 lamps are controlled by the same switch while the third lamp has its own switch.

### 8.3 Electric current

#### Activity 8.6

To demonstrate the flow of charge in a circuit

(Work in groups)

#### Materials

- Straw
- Beaker with water

#### Steps

1. Make a rectangular shape using a straw as shown in Fig. 8.10

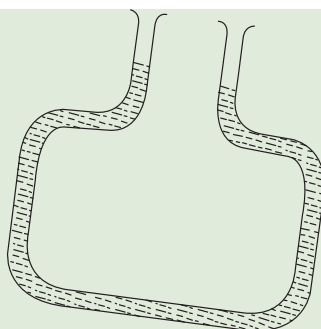

Fig. 8.10: Rectangular shaped straw

2. Pour some water to one opening of the straw and rise one side slightly. What do you observe? Explain.
3. Using the analogy of water in step 2, discuss in your group how electric charges flow in an electric circuit.

### Be responsible



Avoid misusing water. Without water there is no life.

Just like water flows in the straw and comes out through one end, similarly electric charges flow through an electric circuit.

In an electric circuit, bulbs light because charges (electrons) flow through them. The **rate of flow of electric charges from one point to the other in an electric circuit** is called an **electric current**. i.e



$$\text{Current (I)} = \frac{\text{Quantity of charge (Q)}}{\text{Time (t)}}$$

$$I = \frac{Q}{t}$$

The unit of quantity of charge is the **coulomb, C**. The unit of time is the second (s). Then the unit of current, I, is the coulomb per second (C/s). 1 coulomb per second is also called 1 ampere (A). The **SI unit** of electric current is the **ampere (A)**.

### Direction of the flow of electric current

The direction of the flow of electric current is usually shown by an arrow in an electric circuit (Fig. 8.11). Conventionally, the direction of flow of electric current



is shown from the positive terminal to the negative terminal of a cell through the connecting wire as though there are positive charges flowing around the circuit. In reality the charge carriers are electrons which are negatively charged, flowing in the opposite direction.

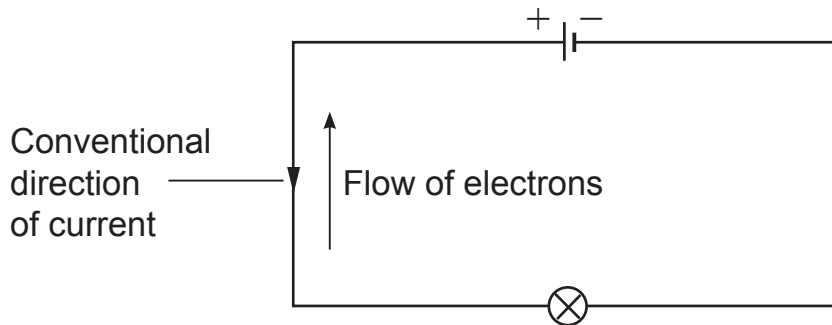

Fig. 8.11: Conventional direction of electric current and electron flow

### Example 8.1

Calculate the amount of charge that passes through a point in a circuit in 3 seconds, if the current in the circuit is 0.5 A.

#### Solution

$$\begin{aligned}\text{Charges } Q &= It \\ &= 0.5 \text{ A} \times 3 \text{ s} = 1.5 \text{ C}\end{aligned}$$

### Example 8.2

How long would it take for a charge of 1.2 C to flow when a current of 0.01 A is flowing in a circuit?

#### Solution

From  $Q = It$ , we make,  $t$ , the subject of the formular

$$t = \frac{Q}{I} = \frac{1.2 \text{ C}}{0.01 \text{ A}} = 120 \text{ seconds or 2 minutes}$$

### Example 8.3

Find the amount of current passing through a lamp, if 600 Coulomb of charge flows through it in 4 minutes.

### Solution

$Q = It$ . We make,  $I$ , the subject of the formula.

$$I = \frac{Q}{t} = \frac{600 \text{ C}}{(4 \times 60)\text{s}} = 2.5 \text{ A}$$

## Measurement of electric current

### Ammeter

#### Activity 8.7

#### To measure electric current

#### Materials

- An ammeter
- A bulb
- Connecting wire
- A switch
- A dry cell
- Digital ammeter
- Analogue ammeter

#### Steps

1. With the help of your teacher select ammeters from the instruments given.
2. Note the range of their scales. Are you able to read the scale?
3. Discuss in your group what the apparatus is used for and how it is connected in an electric circuit.
4. Now connect the circuit as shown in Fig. 8.12.

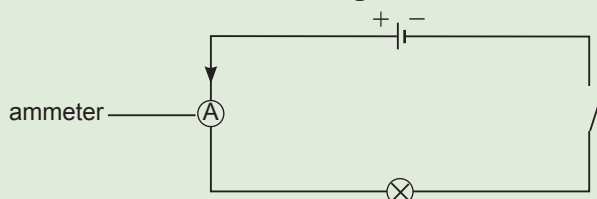

Fig. 8.12: An ammeter connected along the path of an electric current

5. Close the switch and observe what happens to both the bulb and the pointer of the analogue ammeter. In case of the digital ammeter, observe what happens to the display on the screen?). Suggest a reason for this.
6. Repeat the activity but connect the ammeter to the right of the bulb as shown in Fig. 8.13. Observe what happens to the bulb and the ammeter reading. Explain your observations to others.

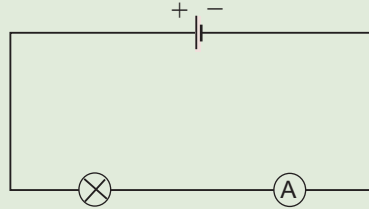
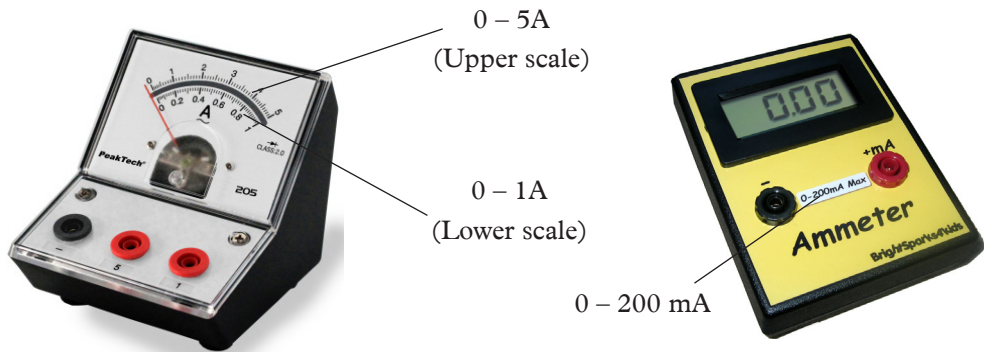

Fig. 8.13: An ammeter connected to the right of the bulb

7. Discuss with your members how to read the magnitude of current from an analogue ammeter.
8. Why do you think ammeters are connected in series in an electric circuit?

**Ammeters** are used to measure electric current in a complete electric circuit. Fig. 8.14(a) shows an analogue multiammeter. It has two positive terminals and one negative terminal. Fig. 8.14(b) shows a digital ammeter.



(a) An analogue ammeter

(b) A digital ammeter

Fig 8.14: Ammeters

An analogue ammeter may have more than one scale (Fig. 8.13(a)). The magnitude of the current determines the scale to be used.

Smaller currents are measured in milliamperes (mA) and microamperes ( $\mu\text{A}$ ).

$$1 \text{ mA} = \frac{1}{1000} \text{ A} = 1 \times 10^{-3} \text{ A}, \quad 1 \mu\text{A} = 1 \times 10^{-6} \text{ A}.$$

Fig. 8.15 shows the symbol of an ammeter.



Fig 8.15: Symbol for an ammeter

An ammeter is connected in series with the circuit components through which current is to be measured. In step 5, the bulb lights and the ammeter records some reading. The same is observed when the bulb and ammeter are interchanged in the circuit, i.e same brightness and same ammeter reading. This shows that an ammeter consumes negligible electric current.

### Reading an analogue ammeter

#### Activity 8.8

#### How to take a reading from an analogue ammeter

(Work in groups)

1. Repeat Activity 8.7 by connecting the ammeter scale in Fig. 8.14(a) to the negative terminal of the power source leading to the negative terminal of the ammeter (referred to as the common terminal (usually black) and positive terminal leading to the 1 A or 5 A terminal positive terminal (usually red or brown in colour) depending on the amount of current to be measured. What do you observe?
2. Sketch in your exercise book the range of the scales used. What does one division represent?
3. Discuss with your members how to read the magnitude of current from an analogue ammeter.

Fig 8.16 shows the scale on an analogue ammeter that measures current in the range 0 – 1 A, or 0 – 5 A.

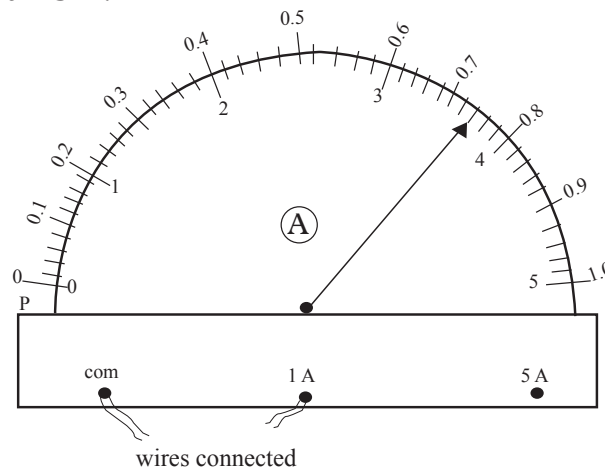

Fig. 8.16: An ammeter with a scale range of 0 – 1 A, 0 – 5 A

When connected to the 1 A terminal, the upper scale running from 0 - 1 A should be used.

We determine the current represented by each smallest division on the upper scale as follows:

5 divisions correspond to ..... 0.1 A

1 division corresponds to .....  $\frac{0.1\text{A}}{5} = 0.02\text{ A}$

In Fig. 8.16, the pointer is on the second mark after the 0.7 mark, hence the ammeter reading is:

$$0.7\text{ A} + (2\text{ divisions} \times 0.02\text{ A}) = 0.7\text{A} + 0.04\text{ A} = 0.74\text{ A}$$

### Example 8.4

What is the reading shown by the pointer in Fig. 8.17, if the full scale range is:

- (a) 0–100 mA?
- (b) 0–250 mA?

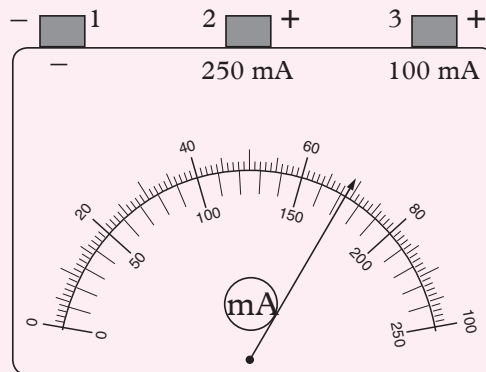

Fig. 8.17: Ammeter reading scale

### Solution

- (a) Full scale deflection = 100 mA. (Use the upper scale)

The pointer is at 69<sup>th</sup> division.

The reading is 69 mA.

- (b) Full scale deflection = 250 mA. (Use the lower scale)

The pointer is between 170<sup>th</sup> and 180<sup>th</sup> divisions. There are 4 divisions of the upper scale corresponding to 10 mA in the lower scale.

∴ 1 division represents 2.5 mA.

Reading = 170 mA + 2.5 mA = 172.5 mA.

The reading is 172.5 mA.

## Exercise 8.2

1. Define an electric current and state its SI unit.
2. A car battery circulates charge round a circuit for 5 minutes. If the current is held at 15 A, what quantity of charge passes through the wire?
3. A charge of 40 coulombs flows through a point on a conducting wire in 15s. Calculate the current flowing in the conductor.
4. Calculate the number of electrons which carry a charge of 1 C. (charge of an electron =  $1.6 \times 10^{-19}$  C).
5. If a charge of 1.5 C passes through a point in a circuit in 0.5 s, calculate the current in the circuit.
6. If the current in a circuit is 2 A, calculate:
  - (a) the charge that passes through a point in the circuit in 0.6 s,
  - (b) the number of electrons possible + through the point per second.
7. What is the reading shown in the ammeter below?

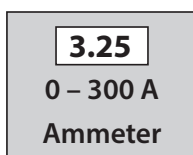

Fig. 8.18: A digital ammeter

## 8.4 Potential difference (p.d)

### Activity 8.9

To define potential difference and identify its SI unit

#### Materials

- Reference books
- Internet

#### Steps

1. Conduct research from internet and reference books on potential difference, be guided by the following questions:
  - (a) What is potential difference?
  - (b) What is the SI unit of potential difference?
  - (c) Define a volt.

2. Compare and discuss your findings with other groups, in class. Do you have the same facts? (Consult your teacher for further guidance).

We can use a water model to explain potential difference (p.d). This model consists of a water pump, water and pipes as shown in Fig. 8.19(a). Fig. 8.19(b) shows an electric circuit which can be compared with the water model.

When the pump is on, water is lifted to point A. At this point water has the maximum potential energy. This potential energy drives the water down the inclined pipe. On reaching point B, the water has lost all the potential energy it had. The pump then provides the water with the necessary energy to climb up to A again. The water therefore flows round the water circuit as long as the pump is on.

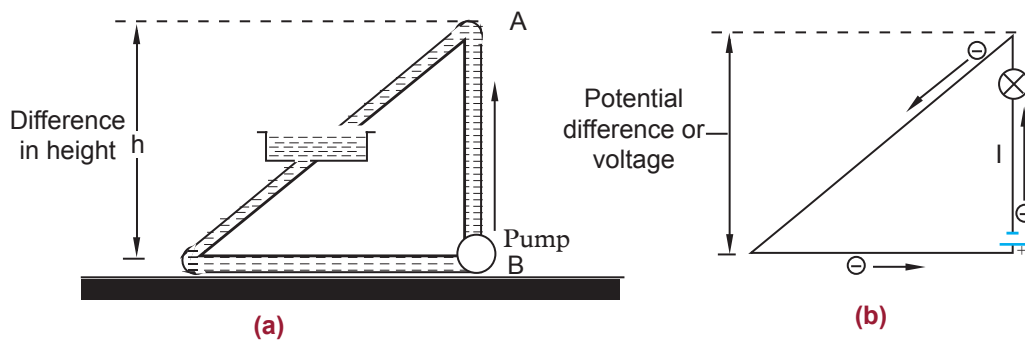



Fig. 8.19: (a) A water model and (b) An electric circuit

In the electric circuit, the electrons move towards the positive terminal of the battery. The battery lifts the electrons up through an electrical height. This electrical height is called a **potential**. The positive and the negative terminals have a difference in potential. This difference in potential or potential difference (p.d) is the one responsible for driving the electric current round the circuit. In the water model, the difference in the height causes water current. If there are no differences in the water levels, as in ponds, water would not flow. Similarly, in electrical circuits the absence of a potential difference results in no electric current.

Potential difference is defined as the **work done in moving one coulomb of charge from one point to the other in an electrical circuit**. The SI unit of potential difference is the **volt (V)**.

	$\text{Volt} = \frac{\text{work done (joule)}}{\text{charge (coulombs)}}$
---	---

The potential difference is also known as the **voltage**.

## The volt

In Fig. 8.20 (a), points A and B are at a potential difference of one volt if the work done in moving one coulomb from A to B is one joule. 1 volt is therefore defined as the energy needed to move one coulomb of charge from one point to another. The voltage between the terminals of a cell indicates the energy supplied to each coulomb of charge in the circuit. For example, a battery with a potential difference of 6 V supplies 6 joules of energy to each coulomb of charge in the circuit. This energy is then converted into other forms of energy like light and heat in bulbs ( Fig. 8.20(b)).

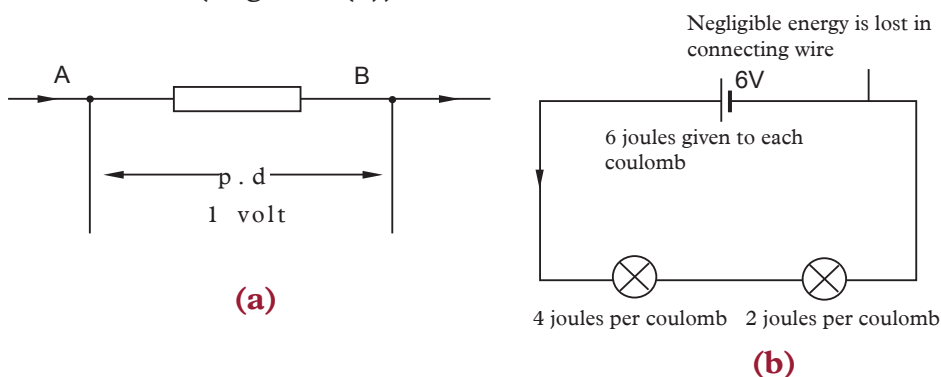

Fig. 8.20: Energy carried by a coulomb of charge

## Measurement of voltage

### Activity 8.10

#### To measure voltage using a voltmeter

#### Materials

- Digital and analogue voltmeters

#### Steps

1. Study the instruments given to you. What is the name of the instruments? Write down its symbols in your exercise book.
2. Note down the range of its scales and discuss them in your group.
3. Discuss the use of the apparatus and how they are connected in an electric circuit.
4. Design an experiment to show how it is used in an electric circuit. Your design should include a well labelled diagram of circuit and how it should be placed in the circuit.

In Activity 8.11, you should have identified the instruments as **a voltmeters**. Fig. 8.21(a) and (b) shows an analogue and digital voltmeter respectively. Fig 8.21(c)



shows the symbol for a voltmeter. A voltmeter is used to measure voltage across a device in an electric circuit.

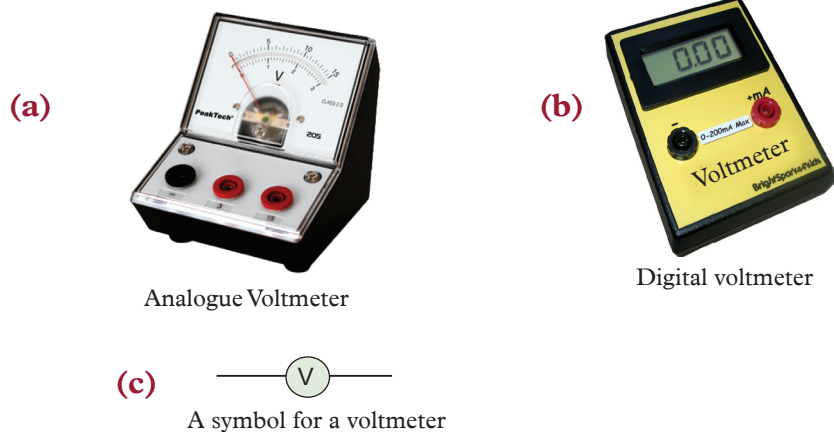

Fig. 8.21: Voltmeters

The positive terminal of voltmeter is connected to the wire from the positive terminal of the cells and the negative terminal to the wire leading to negative terminal. A voltmeter is always parallel to the device whose voltage is to be measured. (See Fig. 8.22).

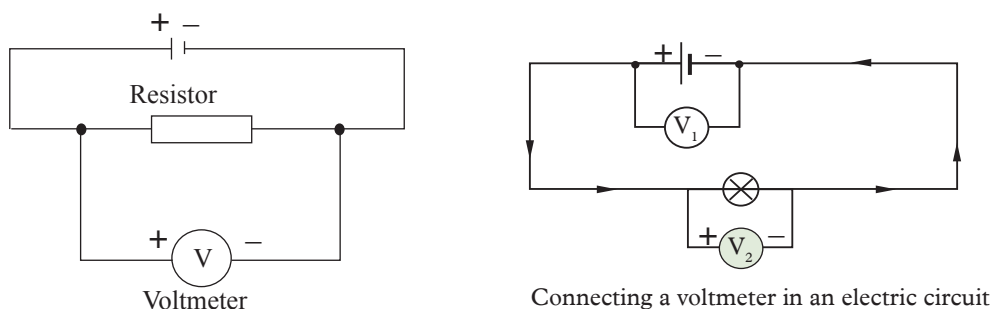

Fig. 8.22: Connecting a voltmeter in a circuit

Voltmeters have uniform scales calibrated in volts or millivolts. The most used scales have a range of 0 – 5 V and 0 – 1.5 V. Fig. 8.24 shows a scale of a voltmeter.

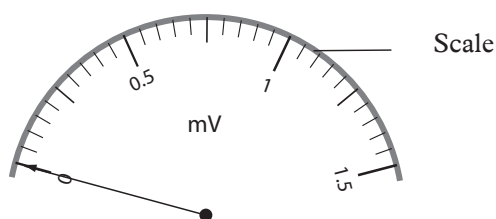

Fig. 8.23: Voltmeter scale

The voltmeter scale is read in the same way as the ammeter.

### Note:



- If the pointer of an ammeter or voltmeter moves in an anticlockwise direction, then interchange the wires on the terminals.

### Exercise 8.3

1. Define the term potential difference and state its SI units.
2. Name the instrument used to measure voltage.
3. Define a volt.
4. In a circuit, 5 joules are used to drive 2 coulombs of charge across a bulb in a simple circuit. Find the potential difference across the bulb?
5. Name the instrument used to measure potential difference.
6. Two cells, A and B connected in parallel are in series with a bulb as shown in Fig. 8.24.

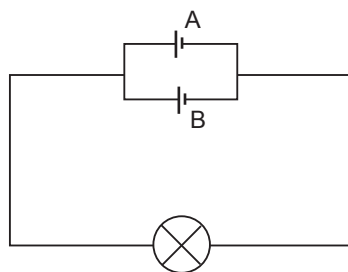

Fig. 8.24: Circuit with parallel cells

Copy the diagram and show where the:

- (a) ammeter should be connected in order to measure the current through cell A.
  - (b) voltmeter should be connected to measure the potential difference across both the bulb and cell B.
7. Fig. 8.25 shows a dual scale of voltmeter.

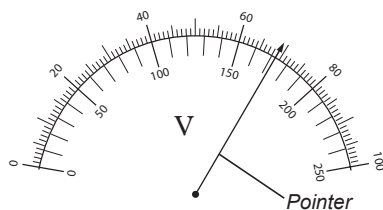

Fig. 8.25: Dual scale of a voltmeter

- (a) What is the reading shown by the pointer in Fig. 8.25, if the range is:
  - (i) 0 – 100 mV
  - (ii) 0 – 250 mV
  - (iii) 0 – 2.5 V
  - (iv) 0 – 0.1 V
  - (v) 0 – 10 V
  - (vi) 0 – 25 V
- (b) Why are different ranges used in ammeters and voltmeters?

## 8.5 Chemical cells

A chemical cell consists of two different metals called electrodes and a conducting liquid called electrolyte. The chemical energy stored in the cell is converted into electrical energy when an electric current flows in the circuit. Chemical cells are classified into either primary or secondary cell.

### 8.5.1 Simple primary cell

#### Activity 8.11

#### To make a simple cell with improvised material

##### Materials

- Lemon
- Copper plate or rod
- Milliammeter or galvanometer
- Zinc plate or rod
- Connecting wires with clips
- Knife

##### Steps

1. Cut two small slits on the skin of the lemon.
2. Push the copper and zinc plates into the slits. Make sure the plates do not touch each other. Why do you think it is necessary that the plates don't touch each other?
3. Connect each plate to the milliammeter using connecting wires as shown in Fig. 8.26.

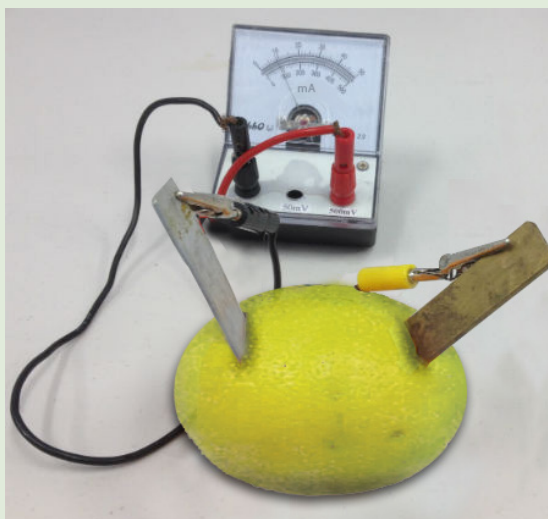

Fig. 8.26: Simple cell circuit of a lemon

Observe what happens to the pointer of the milliammeter. Suggest a reason for your observation.

The set up of the lemon, the metal plates and connecting wires make up a simple electric cell that generates some electric current. The electric current produced makes the pointer of the milliammeter to deflect.

### The working of a simple primary cell

Activity 8.12 will help us to understand how a simple cell works.

#### Activity 8.12

#### To investigate the working of a simple cell

##### Materials

- Zinc plate
- Dilute sulphuric acid
- Connecting wires
- Copper plate
- A bulb

##### Steps

1. Dip the zinc and copper plates into a beaker containing dilute sulphuric acid as shown in Fig. 8.27.

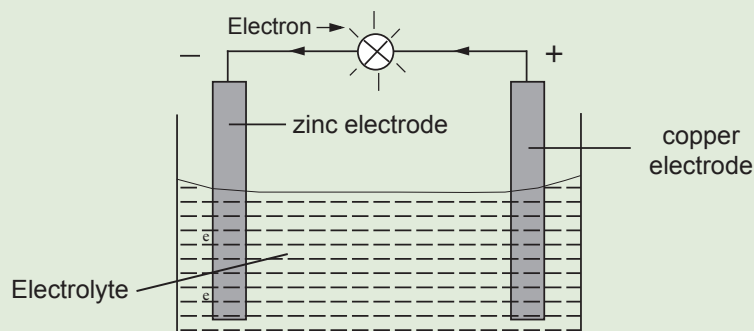

Fig. 8.27: Working of a simple cell

2. Connect the two plates to a bulb and observe what happens to the bulb immediately it is connected. Does the bulb light? What do you think happens in the set up to lead to your observation?
3. Discuss with your group members how a simple cell works.
4. Make a presentation to the whole class.

In Activity 8.12, you must have observed that when the bulb is connected, it lights brightly before dimming down slowly after sometime.

A simple electric cell consists of two different metal plates called **electrodes** and a conducting liquid called **electrolyte**. In activity 8.12, the zinc and copper plates are the electrodes while sulphuric acid is the electrolyte. When the two plates are dipped in the electrolyte and then connected through a wire, the electrolyte creates a negative charge in the zinc plate. The electrons move from the zinc plate

through the wire and bulb to the copper plate. The electric current produced by the flow of electrons makes the bulb to light.

An example of an enhanced simple cell is the dry Leclanche cell that we use in our torches, radios and cameras. Fig 8.28 shows an example of a dry cell.



Fig. 8.28: A dry cell

### Action of the simple cell

When the copper and the zinc plates are connected to a bulb, zinc plate starts to dissolve in the sulphuric acid. Positive zinc ions dissolve into sulphuric acid leaving electrons on the zinc plate. These electrons are the sources of the electric current from zinc to copper plate. At the same time hydrogen ions leave the solution and are deposited on the copper plate. They pick electrons from the copper plate to form hydrogen gas.

Copper plate becomes positively charged and hence can attract electrons from zinc plate (Fig. 8.29).

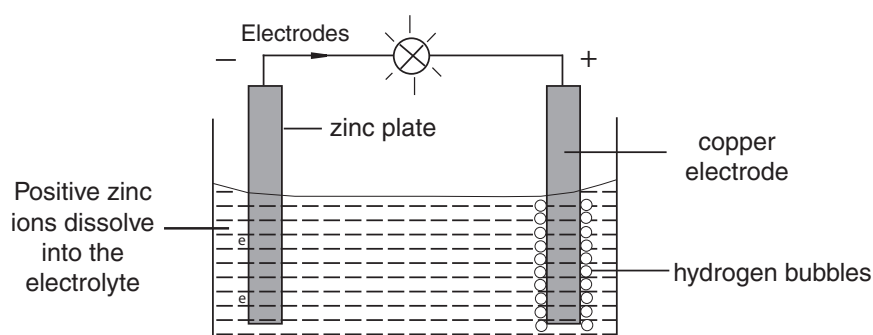

Fig. 8.29: Working of a simple cell

## Defects in a simple cell

### Polarisation

Accumulation of hydrogen gas bubbles around the copper plate makes it difficult for the electrons to flow. This is what causes the bulb to dim. The process by which hydrogen bubbles form around the copper plate is called *polarisation*. This defect can be minimised by adding a *depolariser*, like potassium dichromate. A good depolariser should not react with the electrolyte.

### Local action

When zinc reacts with sulphuric acid, it dissolves and exposes hidden impurities of carbon and iron. These impurities form small cells called *local cells*. These local cells cause the zinc to be used up even when current is not being supplied. This defect is called *local action*. It can be minimised by applying a layer of mercury on the zinc plate in a process called *amalgamation*. In this process mercury dissolves off zinc leaving the impurities buried in the electrode.

### Dry Leclanché cell

A dry Leclanché cell consists of a carbon rod which is surrounded by manganese (IV) oxide mixed with carbon powder dipped in ammonium chloride paste and a zinc case (Fig. 8.30). During the working of the cell, zinc is converted into zinc chloride and hydrogen gas is produced. Manganese (IV) oxide converts the hydrogen produced into water. Hence polarisation is minimised. The carbon powder acts as a *catalyst* i.e. it quickens the working of the manganese (IV) oxide. Local action is still a problem in this cell.

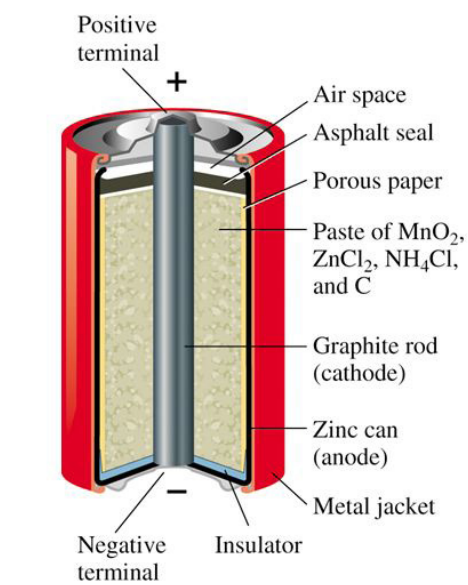

Fig. 8.30: A dry Leclanché cell

### Advantages of Leclanché cell

1. Chemicals used are relatively cheap.
2. A relatively high electrical energy is produced.
3. The depolariser used is a solid and a poor conductor of electric current. It mixes well with the powdered carbon, which is a good conductor of electric current.

### Disadvantages of Leclanché cell

1. It polarises if used continuously.
2. It uses a slow depolariser. More hydrogen is evolved than it can react with.
3. It cannot provide large currents.

## 8.5.2 Secondary cells

A secondary cell stores electrical energy in a chemical form. It must first be *charged* with electricity. The chemical reactions in a secondary cell, unlike in a primary cell, are *reversible*. i.e the electrical energy produced during charging is changed to chemical energy and stored in the cell. When the cell is in use the stored chemical energy is once again changed to electrical energy.

### Activity 8.13

#### Making a simple secondary cell

##### Materials

- Two clean lead plates
- A switch
- Beaker containing dilute sulphuric acid
- A battery
- A meter

##### Steps

1. Introduce two clean lead plates into a beaker containing dilute sulphuric acid. Connect the circuit as shown in Fig. 8.31. Why is it necessary for the plates to be clean?

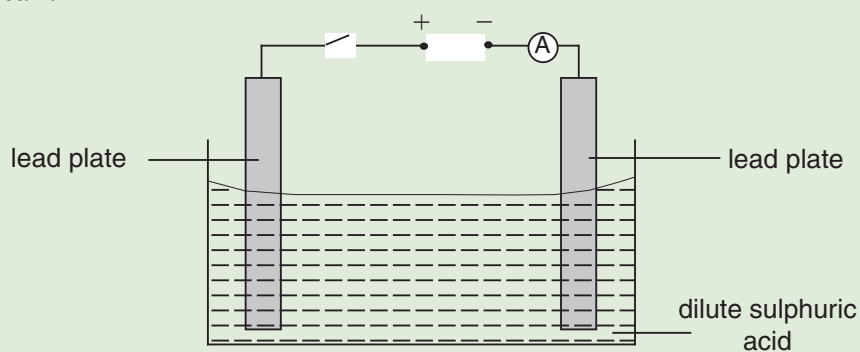

Fig. 8.31: A simple secondary cell

2. Close the switch and allow the current to flow for some time. What happens to the two lead plates? What do you think causes the observation you have made?
3. What do you think will be the effect of using concentrated sulphuric acid in the activity?

The lead plate connected to the negative terminal of the battery becomes coated with a chocolate brown colour. The other plate remains grey.

Repeat the experiment but replace the battery with a bulb and observe what happens. The bulb lights showing that a cell has been made. On allowing the current to flow for some time, the two plates become coated with a white substance and the brightness of the bulb decreases slightly.

### Activity 8.14

#### To demonstrate how a battery works

#### Materials

- Two lemons
- Two copper plates or rod
- Milliammeter or galvanometer
- Two zinc plates or rod
- Connecting wires with clips
- Knife

#### Steps

1. Repeat Activity 8.13 and observe the extent of the milliammeter pointer.
2. Now connect another one lemon in series with the first one as shown in Fig. 8.32. Observe the extent of the milliammeter pointer.



Fig 8.32: Two simple cells connected in series



3. Compare the deflection of the pointer when two lemon simple cells are used in step 2 and when one was used in step 1. What do you notice? Draw a conclusion for this observation.
4. How can you relate this observation to how a battery works?

When two or more simple electric cells are connected in series (positive terminal to negative terminal), they constitute a **battery**. The electric current produced by the battery is more than that produced by one cell.

An example of a practical battery is a car battery shown in Fig. 8.33.



Fig. 8.33: A car battery

Fig. 8.34 shows the symbol for a battery in a circuit as used in a circuit diagram.

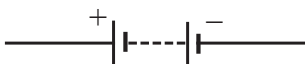

Fig. 8.34: Battery symbol

### Lead-acid accumulator

There are many different types of secondary cells available in the market today. One of the most commonly used secondary cell is the *lead acid accumulator* (Fig. 8.35).

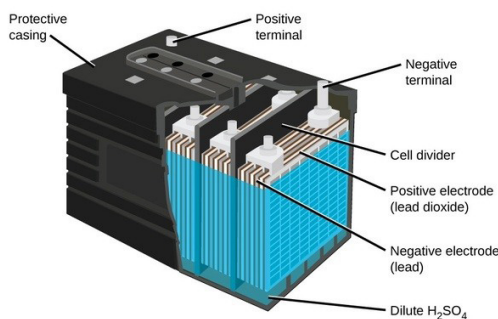

Fig. 8.35: A lead acid accumulator

A lead acid accumulator consists of positive and negative plates which are made of lead-antimony alloy. These plates have a mesh-like grid. The positive plate is packed with lead (IV) oxide (chocolate brown in colour), while the negative plate

is packed with spongy lead (grey in colour). The plates are dipped into sulphuric acid. Care must be taken when handling this electrolyte as it is very corrosive. It is strong enough to burn holes in clothing and can cause damage to the skin and eyes. The plates and the electrolyte are placed in a strong plastic container.

Each cell has a screw cap which can be removed when checking the state of sulphuric acid. Each of these caps have a small vent/hole to allow gases to escape. The cells have lower internal resistance as compared to the primary cell.

As electrical energy is taken from the cell, sulphuric acid reacts with lead (IV) oxide and lead to form lead sulphate (white solid). This makes the density of sulphuric acid to fall. When density of sulphuric acid is very low, the cell cannot provide any more electrical energy. It is said to be *discharged (flat)*. To regain energy, the cell is recharged by connecting a direct current (d.c) source as shown in Fig. 8.37. When connected in this manner, chemical reactions are reversed. The density of sulphuric acid is restored. The lead sulphate is converted to lead and lead (IV) oxide. The charging is complete when hydrogen and oxygen bubbles are freely released (*gassing*) from the plates. The *gassing* is as a result of the charging current decomposing the water present.

The density of sulphuric acid is checked using an instrument called *hydrometer*.

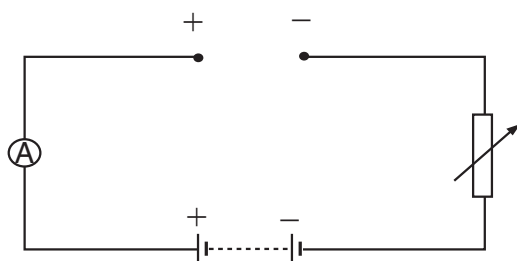

Fig. 8.36: Charging a battery

### Care and maintenance of an accumulator

1. The plates should always be covered with the electrolyte. However, during usage water evaporates and alters the recommended density of sulphuric acid. Distilled water is then added to bring the density of sulphuric acid to the normal value. This is called *topping-up*. Acid may be added only in case of spillage.
2. Charge the cell regularly. When the cell is left in the discharged state for long period, lead (II) sulphate deposited on the plate harden up and becomes very difficult to convert back to lead (IV) oxide. The cell is then permanently damaged.
3. Never short circuit the cells; i.e avoid the two electrodes coming in direct contact with each other. This may lead to large currents be drawn from the

battery resulting in the weakening of lead (IV) oxide and lead in the grids causing them to fall off.

4. When recharging, leave the screw caps off the cell or loosen them to allow the gas formed during the charging process to escape.
5. Avoid direct flame with the cell as the hydrogen and oxygen gas if formed, may combine and explode.
6. The terminals should be cleaned occasionally with hot water to dissolve off any lead (II) sulphate that may form on them. Greasing also helps in preventing the formation of lead (II) sulphate.

#### Advantages of a secondary cell

1. It is cheap to make.
2. It can produce large currents.
3. It can be re-charged.

#### Disadvantages of a secondary cell

1. The electrolyte is corrosive.
2. It produces gases which may explode if ignited.
3. It cannot produce large currents in cold weathers.

### Exercise 8.4

1. Define the term electric circuit.
2. Draw a diagram for a simple circuit.
3. What is an open circuit?
4. Draw a labelled diagram of a simple cell.
5. The following are some symbols of electric components.



Fig. 8.37: Symbols of electric components

- (a) Name the electric components represented by these symbol.
- (b) Using these symbols, draw a simple circuit diagram.
6. When a small bulb is connected between the two plates of a simple cell, the bulb lights. However the brightness fades after some time.

- (a) Why does the bulb light?
- (b) Explain why the brightness fades. How can the effect be minimised?
7. Draw a labelled diagram of a:
- (a) Primary cell.
- (b) Secondary cell. In each case name the cell you have drawn
- (c) In what ways does a primary cell differ from a secondary cell.
8. State advantages and disadvantages of an accumulator over a dry cell.
9. Explain how you should maintain and care for an accumulator?
10. What is the function of a depolariser in simple and Leclanché cell? Give an example of a depolariser.
11. Why should the depolariser used in Leclanché cell be mixed with powdered carbon?

## 8.6 Project work

### Making a simple cell from locally available materials

#### Suggested materials

Citrus fruit, potatoes or onion to provide the electrolyte, zinc plates from old dry cells, thick copper wire.

#### Assembly

- Assemble the apparatus as shown in Fig. 8.38.

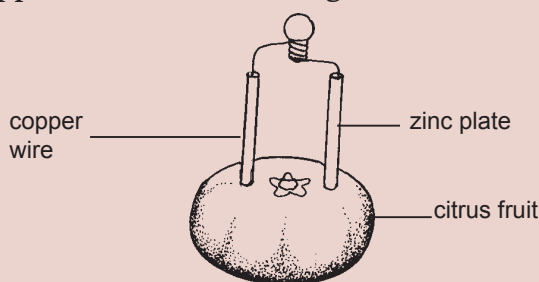

Fig. 8.38: A symbol cell

- Pierce through the skin and insert the two electrodes. The current from this cell is very small. Try and connect a number of them in series and see whether a small bulb can be lit.

## Topic summary

- Electric circuit is a complete path through which charge flow.
- An ammeter is an instrument used to measure current.
- A voltmeter is an instrument used to measure potential difference (p.d.).
- Potential difference (V) is the work done in moving a unit charge between two points in a closed circuit.
- Potential difference (p.d.) = work done per unit charge.

$$\text{p.d. (V)} = \frac{\text{work done (in joules)}}{\text{charge (in coulombs)}} \quad \text{i.e. } V = \frac{W}{Q}$$

Its SI unit is the volt (1 volt = joule per coulomb 1 J/C)

- Electric current is the rate of flow of charge.

$$\text{Current, } I = \frac{\text{charge, } Q}{\text{time, } t}$$

- Whenever an electric current passes through a conductor, electrical energy is converted to other forms of energy e.g. heat, light.
- Electric current causes chemical break down of solutions when passed through them.
- Primary cells cannot be recharged while secondary cells are rechargeable.
- Electric cells provide energy to drive an electric current in a circuit.
- Secondary cells can last for a long time if they are well maintained.

## Topic Test 8

1. Define the following terms:
  - (a) Electrical circuit.
  - (b) Electric current.
  - (c) Potential difference.
2. A charge of 200 coulombs flows through a lamp in 10 minutes. Determine the current flowing through the lamp.
3. Find the amount of charge that will pass through a certain point in a circuit, if 5 mA flows through the point for 6 hours.
4. Fig. 8.40 shows two circuit diagrams.

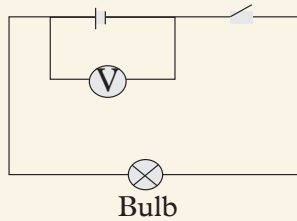

(a) Open circuit

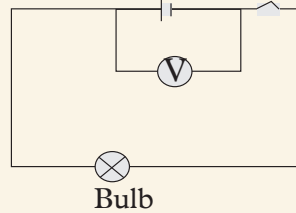

(b) Closed circuit

Fig. 8.39: An electric circuit

What type of voltage is measured when:

- (a) the switch is open.
  - (b) the switch is closed.
5. With the aid of a diagram, describe how conventional current and electrons flow in an electric circuit.
  6. A current of 0.12 A flows in a circuit for 9 minutes. How much charge passes through a given point in the circuit?
  7. 1 800 coulombs of charge are passing through a point in an electric circuit in 15 minutes. Determine the amount of electric current in the circuit.
  8. What instrument is used to measure electric current? How is it connected in a circuit?
  9. Identify the instruments in Fig. 8.40 and state the reading on them in SI units.

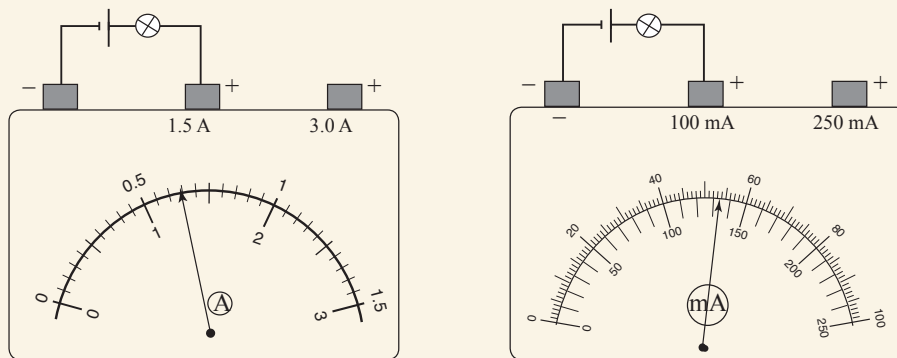
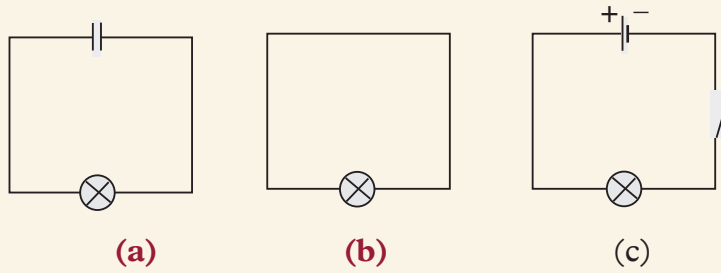

Fig. 8.40: Electrical instruments

10. Which of the bulb in the circuits shown in Fig. 8.41 will light if the switch is closed? Explain your answer.



*Fig. 8.41: Bulbs in a circuit*

- 11.** Which materials are used in the construction of a simple cell?
- 12.** Explain why the current in a simple cell decreases rapidly when in use. Describe how to minimise this decrease in current.
- 13.** Describe a project to make a simple battery.



South Sudan

# Secondary Physics

# 1

Student's Book

Secondary Physics has been written and developed by Ministry of General Education and Instruction, Government of South Sudan in conjunction with Subjects experts. This course book provides a fun and practical approach to the subject of Physics, and at the same time imparting life long skills to the students.

The book comprehensively covers the Secondary 1 syllabus as developed by **Ministry of General Education and Instruction.**

**Each year comprises of a Student's Book and teacher's Guide.**

**The Student's Books provide:**

- Full coverage of the national syllabus.
- A strong grounding in the basics of Physics.
- Clear presentation and explanation of learning points.
- A wide variety of practice exercises, often showing how Physics can be applied to real-life situations.
- It provides opportunities for collaboration through group work activities.
- Stimulating illustrations.



**All the courses in this secondary series were developed by the Ministry of General Education and Instruction, Republic of South Sudan. The books have been designed to meet the secondary school syllabus, and at the same time equipping the students with skills to fit in the modern day global society.**

This Book is the Property of the Ministry of General Education and Instruction.

**This Book is not for sale.**

Any book found on sale, either in print or electronic form, will be confiscated and the seller prosecuted.

**Funded by:**



**Published by:**

