



South Sudan



Secondary Physics

Student's Book

2



**This Book is the Property of the
Ministry of General Education
and Instruction.**

This Book is not for sale.

Funded by:



**GLOBAL
PARTNERSHIP
for EDUCATION**
quality education for all children

How to take care of your books.

Do's

- 1. Please cover with plastic or paper. (old newspaper or magazines)**
- 2. Please make sure you have clean hands before you use your book.**
- 3. Always use a book marker do not fold the pages.**
- 4. If the book is damaged please repair it as quickly as possible.**
- 5. Be careful who you lend your schoolbook to.**
- 6. Please keep the book in a dry place.**
- 7. When you lose your book please report it immediately to your teacher.**

Don'ts

- 1. Do not write on the book cover or inside pages.**
- 2. Do not cut pictures out of the book.**
- 3. Do not tear pages out of the book.**
- 4. Do not leave the book open and face down.**
- 5. Do not use pens, pencils or something thick as a book mark.**
- 6. Do not force your book into your schoolbag when it is full.**
- 7. Do not use your book as an umbrella for the sun or rain.**
- 8. Do not use your book as a seat.**

South Sudan

SECONDARY

2

Physics

Student's Book 2



This book is the property of the Ministry of General Education and Instruction.

THIS BOOK IS NOT FOR SALE

Funded by:



GLOBAL
PARTNERSHIP
for EDUCATION

quality education for all children

Published in 2018 by:
Longhorn Publishers (K) Ltd.,
Funzi Road, Industrial Area,
P.O. Box 18033 – 00500,
Nairobi, Kenya.

©2018, THE REPUBLIC OF SOUTH SUDAN, MINISTRY OF GENERAL
EDUCATION AND INSTRUCTION.

All rights reserved. No part of this book may be reproduced by any means
graphic, electronic, mechanical, photocopying, taping, storage and retrieval
system without prior written permission of the Copyright Holder.

Pictures, illustrations and links to third party websites are provided
in good faith, for information and education purposes only.

Contents

UNIT 1: BEHAVIOUR OF LIGHT AT CURVED SURFACES 1

Topic 1: Reflection of light at curved surfaces 2

Reflection of light at shiny curved surfaces	2
Application of laws of reflection at curved mirrors	3
Reflection terms used in concave and convex mirrors.....	5
Image formation by spherical mirrors.....	11
Locating images by constructing ray diagrams	14
Curved mirrors equation and magnification equation.....	19
Applications of curved reflecting surfaces	22
Project work.....	25
<i>Topic summary</i>	<i>27</i>
<i>Topic Test 1</i>	<i>29</i>

Topic 2: Refraction of light in thin lenses 33

Definition of a lens	33
Types of lenses	34
Terms used in thin lenses.....	36
Image formation by converging lenses	40
Locating images by simple ray diagrams and describing their characteristics	41
The lens formula.....	48
Sign Convention (Real is positive).....	50
Magnification formula of the lens.....	51
Power of a lens	55
Applications of thin lens	59
<i>Topic summary</i>	<i>68</i>
<i>Topic Test 2</i>	<i>70</i>

UNIT 2: FORCES AND TURNING EFFECTS 73

Topic 3: Moment of a Force 74

Moment of a force 74

The principle of moments 78

Couple..... 84

Centre of mass of a body 87

Applications of moment of a force 91

Topic summary..... 93

Topic Test 3..... 93

Topic 4: Centre of Gravity and Equilibrium..... 95

Centre of gravity and centre of mass of a body..... 96

Centre of gravity (c.g) of regular lamina 97

Centre of gravity (c.g) of irregular lamina 98

Effect of position of centre of gravity on the
state of equilibrium of a body..... 100

Factors affecting the stability of a body..... 104

Applications of the position of centre of gravity..... 105

Topic summary..... 107

Topic Test 4..... 108

UNIT 3: WORK, ENERGY AND POWER 111

Topic 5: Work, Energy and Power 112

Work..... 112

Power 122

Energy 126

Forms of energy 127

Work and energy relationship..... 136

Sources of energy 137

Renewable and non renewable sources of energy 144

Environmental effects of the use of energy sources..... 146

Energy transformations 148

Law of conservation of energy..... 153

The law of conservation of mechanical energy	154
Ways of conserving energy	158
Energy efficiency	159
Project	160
<i>Topic summary</i>	<i>163</i>
<i>Topic Test 5</i>	<i>164</i>
UNIT 4: MACHINES	167
Topic 6: Machines	169
Definition of simple machines	169
Mechanical advantage, velocity ratio and efficiency of machines	170
Types of simple machines	174
<i>Topic summary</i>	<i>193</i>
<i>Topic Test 6</i>	<i>194</i>
UNIT 5: THE PROPERTIES OF WAVES	197
Topic 7: Introduction to Waves	198
Oscillations	198
Characteristics of an oscillation	199
Factors affecting oscillations	200
The concept of a wave	201
Characteristics of wave motion	207
<i>Topic summary</i>	<i>215</i>
<i>Topic Test 7</i>	<i>216</i>
Topic 8: Sound Waves	218
Production of sound	218
Sources of sound waves	220
Nature of sound waves	221
The concept of Audible Range	222
Ultrasonic sound	224
Characteristics of sound waves	227

Propagation of sound	229
Speed of sound in solids, liquids and gases	230
Reflection of sound waves	234
Sound pollution	240
Topic summary	241
Topics Test 8	242
UNIT 6: HEAT TRANSFER.....	245
Topic 9: Heat Transfer	246
Heat and temperature.....	246
Methods of heat transfer.....	247
Thermal expansion.....	261
<i>Topic summary.....</i>	<i>277</i>
<i>Topics Test 9.....</i>	<i>277</i>
UNIT 7: MAGNETISM	279
Topic 10: Magnetism.....	280
Definition of a magnet.....	280
Magnetic and non-magnetic materials	281
Properties of magnets	283
Test for magnetism	285
Types of magnets	288
Magnetic field pattern around a magnet	291
Magnetisation and demagnetisation	294
The effect of magnetic materials on the magnetic field	305
Methods of storing magnets.....	306
<i>Topic summary.....</i>	<i>309</i>
<i>Topics Test 10</i>	<i>310</i>

Propagation of sound	229
Speed of sound in solids, liquids and gases	230
Reflection of sound waves	234
Sound pollution	240
Topic summary	241
Topics Test 8	242
UNIT 6: HEAT TRANSFER.....	245
Topic 9: Heat Transfer	246
Heat and temperature.....	246
Methods of heat transfer.....	247
Thermal expansion.....	261
<i>Topic summary.....</i>	<i>277</i>
<i>Topics Test 9.....</i>	<i>277</i>
UNIT 7: MAGNETISM	279
Topic 10: Magnetism.....	280
Definition of a magnet.....	280
Magnetic and non-magnetic materials	281
Properties of magnets	283
Test for magnetism	285
Types of magnets	288
Magnetic field pattern around a magnet	291
Magnetisation and demagnetisation	294
The effect of magnetic materials on the magnetic field	305
Methods of storing magnets.....	306
<i>Topic summary.....</i>	<i>309</i>
<i>Topics Test 10</i>	<i>310</i>

Behaviour of light at curved surfaces

Topics in the unit

Topic 1: Reflection of light at curved surfaces

Topic 2: Refraction of light in thin lenses

Learning outcomes

Knowledge and Understanding

- Understand the behaviour of light at curved surfaces.

Skills

- Determine the focal point of curved mirrors and design a solar concentrator using curved mirrors.
- Observe carefully.
- Predict what might happen.
- Use appropriate measures.
- Collect and present results appropriately in writing or drawing.
- Interpret results accurately.
- Report findings appropriately.
- Construct images formed by curved mirrors and thin lenses using ray diagrams.

Attitudes

- Show curiosity in carrying out experiments.

Key inquiry questions

- How are images formed by curved surfaces and thin lenses and why are they different from those formed by plane surfaces?
- Why are curved mirrors important?
- Why are curved surfaces used in reflecting telescope and parabolic mirrors?
- Why and how are thin lenses important in optical instruments?

Reflection of light at curved surfaces

Unit outline

- Reflection of light at shiny curved surfaces
- Application of laws of reflection at curved surfaces
- Reflection terms used in curved mirrors (principal axis and principal focus, centre of curvature and other related terms)
- Spherical mirrors (concave and convex)
- Images formation by spherical mirrors
- $\frac{1}{f} = \frac{1}{v} + \frac{1}{u}$ and $m = \frac{v}{u}$
- Applications of spherical/curved mirrors
- Locating images by constructing of ray diagrams
- Project work – construction of a solar concentrator

Introduction

Mirrors are not always flat. In secondary 1, we learnt about reflection at plane mirrors. In this topic we will learn about reflection at curved mirrors and how the curved mirrors are applied in optical instruments such as the telescope, side mirrors of a car and others.

1.1 Reflection of light at shiny curved surfaces

Activity 1.1

To demonstrate reflection of light at shiny curved surfaces

(Work in groups)

Material: New spoons, curved mirrors, pieces of dry cloth

Steps

1. Take a new spoon and polish it using a dry cloth.
2. What is the shape of the spoon?
3. On both sides of the spoon form an image of your face.
4. Describe the nature of the images formed by curved surfaces of the spoon.
5. Why do you think the images are not the same?
6. Discuss your observations with other groups.

Curved reflecting surfaces are broadly classified as *concave*, *convex* and *parabolic* depending on their shapes.

In this unit we will study the curved mirrors. Such mirrors are also called spherical mirrors. Spherical mirrors can be thought of as a portion of a sphere that are cut off then silvered on one of the surface to form a reflecting surface. There are three types of spherical mirrors i.e. the *concave*, *convex* and *parabolic mirrors*.

Concave mirrors are silvered on the inside of the sphere while convex mirrors are silvered on the outside of the sphere.

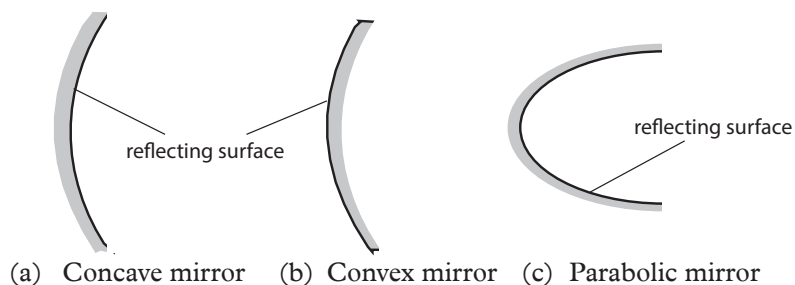

Fig. 1.1: Curved mirrors

When a beam of light is projected on the curved mirrors, the rays are reflected as shown.

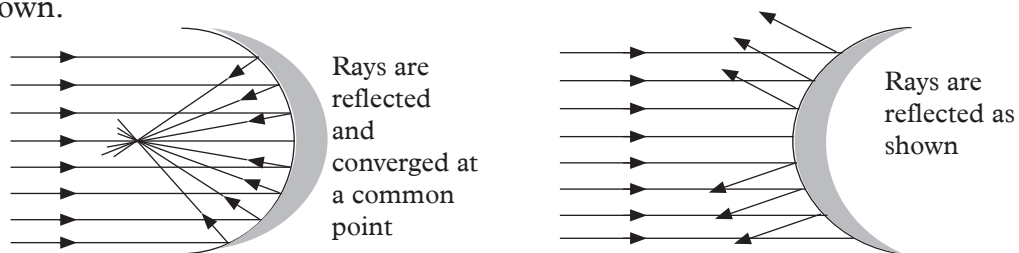

Fig 1.2: Reflection of light at curved surfaces

These curved reflectors are usually made from highly polished metals or glass.

1.2 Application of laws of reflection at curved mirrors

Activity 1.2

To demonstrate application of laws of reflection at curved mirrors

(Work in groups)

Materials: Curved mirrors (convex and concave), source of light (ray box)

Steps

1. Using five white rays from the ray box, strike the rays straight onto the concave mirror. (See the figure below).

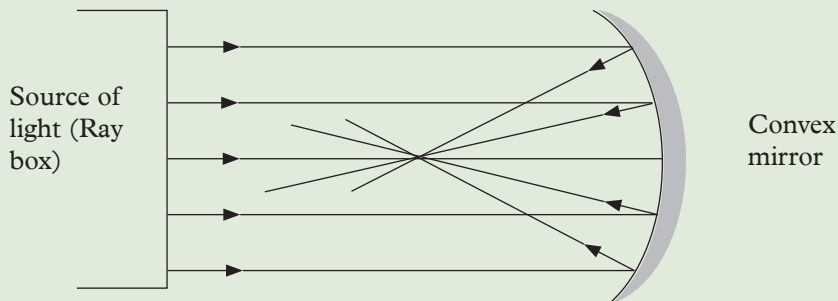

Fig 1.3 : Beam of light shone at the concave mirror

2. Draw the surface of the mirror and trace the incident and reflected rays. Indicate the incoming and the outgoing rays with arrows in the appropriate directions.
3. Use the compass to draw circles that match the curvature of the mirror. Measure the radius of the sphere of which the mirror forms a part.
4. Measure and record the distance from the centre of mirror to the point where the rays converge.
5. What is the size of angle of incidence and angle of reflection? Are they equal?
6. How are the laws of reflection of light applicable in the above experiment?
7. Repeat steps 1 to 4 for a convex mirror.

In the previous class, we learnt about laws of reflection of light. That is:

1. The incident ray, the reflected ray and the normal, at the point of incidence all lie in the same plane.
2. The angle of incidence is equal to the angle of reflection.

To apply the above laws on reflection of light at curved surfaces for each incident ray, a normal line at the point of incidence on a curved surface must be drawn and then the laws of reflection are applied. The two rules on curved mirrors that rely on the above are:

1. Any incident ray travelling parallel to the principal axis on the way to the mirror will pass through the *focal point* upon reflection.
2. Any incident ray passing through the focal point on the way to the mirror will travel parallel to the principal axis upon reflection.

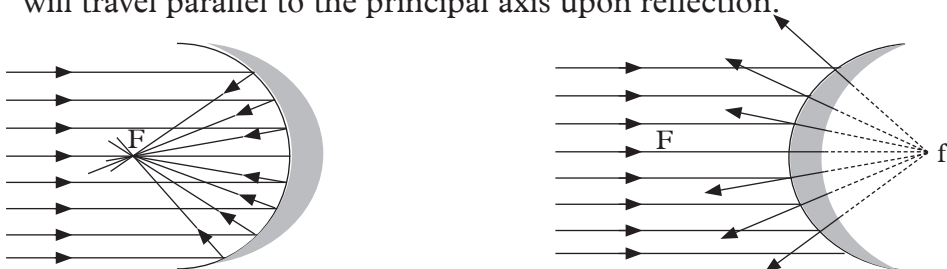

Fig. 1.4: Reflection of light at curved mirrors

1.3 Reflection terms used in concave and convex mirrors

(a) The pole, P

The pole, P, of a curved mirror is the geometric centre of the reflecting surface (Fig. 1.5).

(b) The centre of curvature, C

The centre of curvature, C, of a curved mirror is the centre of the sphere of which the mirror forms a part (Fig. 1.5).

(c) The principal axis

The principal axis of a curved mirror is a line passing through the pole, P, and the centre of curvature, C. It is normal to the reflecting surface (Fig. 1.5).

(d) The radius of curvature, r

The radius of curvature, r, of a curved mirror is the radius of the sphere of which the mirror forms a part (Fig. 1.5).

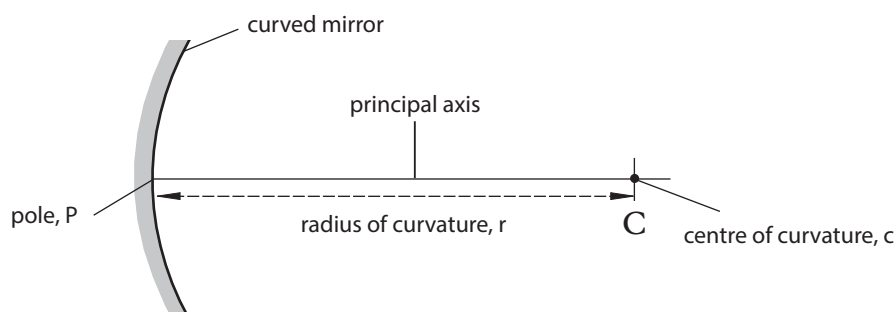

Fig. 1.5: The pole, P, the centre of curvature, C, the principal axis and the radius of curvature, r, of a curved mirror

(e) Principal focus, F

Principal focus, f is the point of axis of a mirror where parallel rays of light converge or from which they appear to diverge after reflection.

1.3.1 Principal focus of a concave mirror

Activity 1.3

To locate the principal focus of a concave mirror

(Work in groups)

Materials: a match stick, large concave mirror made from aluminium foil

Steps

1. Move outside on a sunny day.
2. What is the meaning of the term principal focus?
3. Point the concave mirror towards the sun.
4. Bring the match stick in front of the mirror.
5. Move the concave mirror away from the stick until a white spot forms on the head of the stick. Why do you think the spot forms at that point?
6. Hold the stick in that position for some time. Record what happens. Explain your observations

Consider a set of *incident rays* parallel and close to the principal axis of a concave mirror. The reflected rays pass through a point on the principal axis after reflection by the mirror. This point is called the **principal focus, F**, since all the rays are brought to focus at this point after reflection as shown in Fig. 1.6.

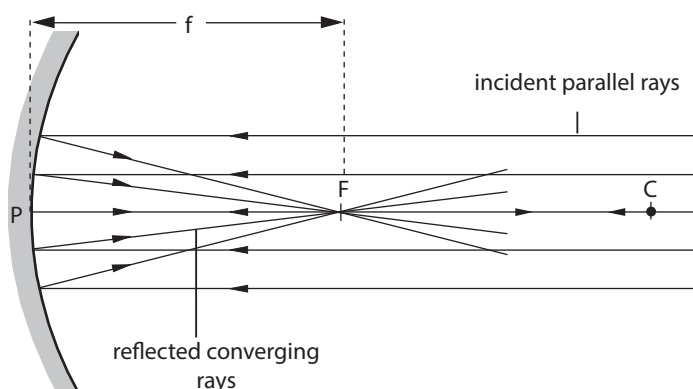

Fig. 1.6: Real principal focus

Since this point can be focused on a screen, it is called *real principal focus*. Images that can be focused on a screen are called *real images*.

1.3.2 Principal focus of a convex mirror

For a set of incident rays parallel and close to the principal axis, the reflected rays appear to diverge from a fixed point on the principal axis after reflection by the convex mirror. This is the principal focus for the convex mirror (Fig. 1.7). This

is a virtual principal focus as it cannot be projected onto a screen. Images that cannot be focused on screen are called virtual images.

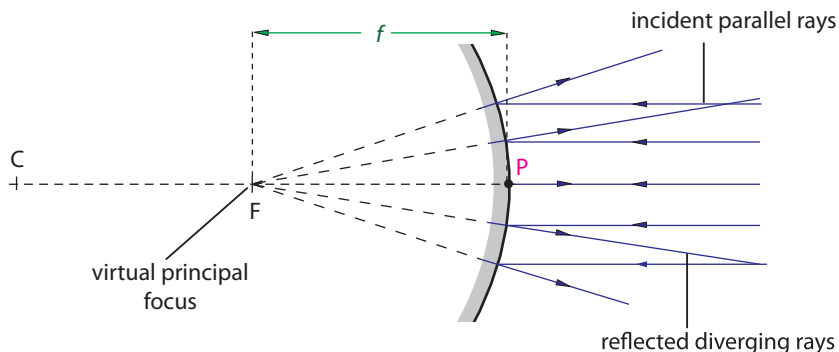

Fig. 1.7: Virtual principal focus

1.3.3 Focal plane

1.3.3.1 Experiments to measure the focal length of a concave mirror

Activity 1.4

To determine the focal length of a concave mirror using an illuminated object placed at the centre of curvature, C, of the mirror

(Work in groups)

Materials: concave mirror, a holder, candle, cross wire, metre rule

Steps

1. The object used is a hole and a cross-wire in a white screen illuminated by a candle or an electric lamp.
2. Place a concave mirror, mounted in a holder, in front of the illuminated hole.
3. Adjust the height of the holder so that the principal axis of the mirror is almost in line with the hole i.e. the pole, P, of the mirror in the same horizontal level as the hole. (Fig. 1.8).

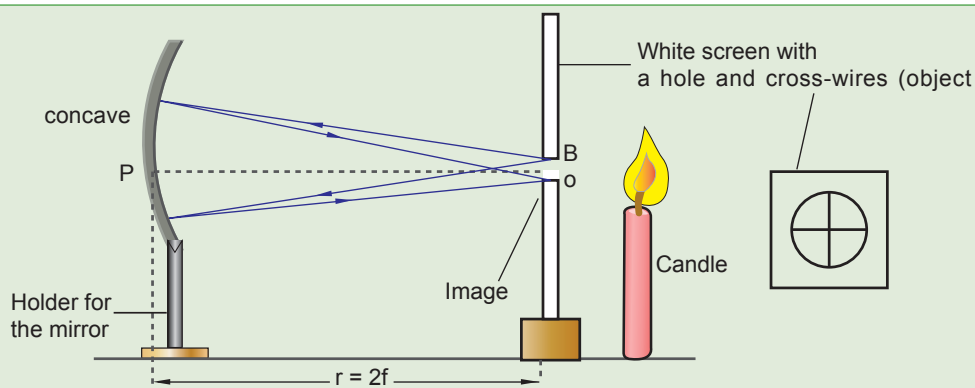

Fig. 1.8: Set up to determine the focal length of a concave mirror

4. Move the mirror to and fro in front of the screen until a sharp image of the object is formed on the screen adjacent to the object. At this position, measure the distance between the object and the image. At this position, the object and the image are at the same distance from the mirror.
5. Measure the distance between the pole, P , of the mirror and the screen. What do you notice when the distance is half? Explain.
6. Which other experiment do you think of that can be used to determine the focal length of a mirror. Design and conduct the experiment. Record the observations and explain them and the findings.

The distance between the pole and the screen is the radius of curvature, r , of the mirror. Half this distance is the *focal length*, f , of the mirror.

Activity 1.5

To design and approximate the focal length of a concave mirror

(Work in groups)

Materials: concave mirror, screen

Instructions

1. In this activity you will design and carry out an investigation to determine the focal length of a concave mirror by approximation method.
2. By modifying the set-up used in the previous activity and the materials provided to you, conduct the investigation. Sketch the new set-up.
3. Write a brief procedure of your investigation.
4. Execute the procedure carefully, and measure the focal length.
5. Suggest some possible sources of errors in your investigation and how they can be reduced.
6. Write a report for your investigation and present it to the rest of the class.

When a set of parallel rays are incident on a concave mirror at an angle to the principal axis as shown in Fig. 1.9, the reflected rays converge to a point, on a plane called the focal plane. The focal plane is a plane which passes through the principal focus and is perpendicular to the principal axis.

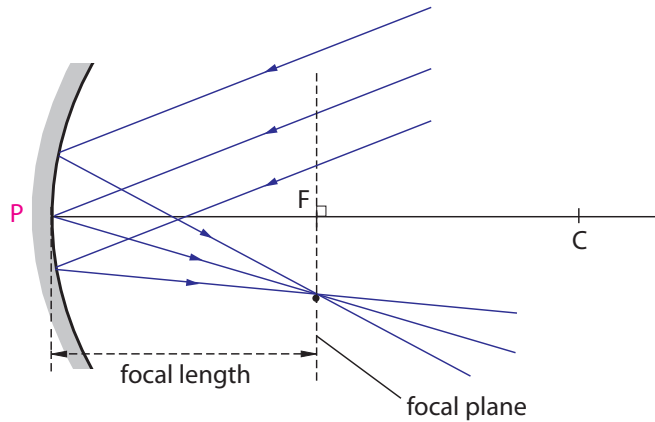

Fig. 1.9: Focal plane of a concave mirror.

The distance between the focal point (F) and the centre of the mirror (P) is called the **focal length**.

Relationship between the radius of curvature, r , and the focal length, f , of a curved mirror

For spherical mirrors $FP = FC$, Fig 1.9.

But $PC = r$, the radius of curvature and $PF = f$, the focal length

$$\therefore PC = PF + FC = 2PF = 2f.$$

$$\therefore r = 2f \text{ or } f = \frac{r}{2}$$

Thus the focal length is half the radius of curvature.

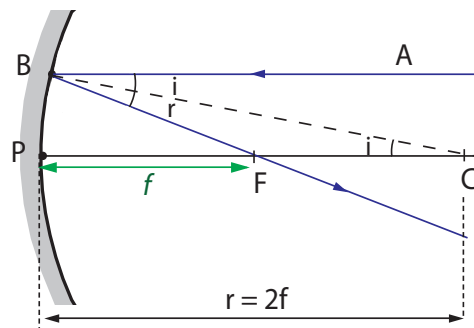

Fig. 1.10: The focal length is half the radius of curvature.

1.3.4 Caustic curve

For a concave mirror, the incident rays parallel and close to the principal axis, called the **paraxial rays**, converge at the principal focus (F). However the incident rays parallel but not close to the principal axis, called the **marginal rays**, are brought to focus at a different point say Q as shown in Fig. 1.11. The incident ray between the paraxial and marginal rays will come to focus between Q and F.

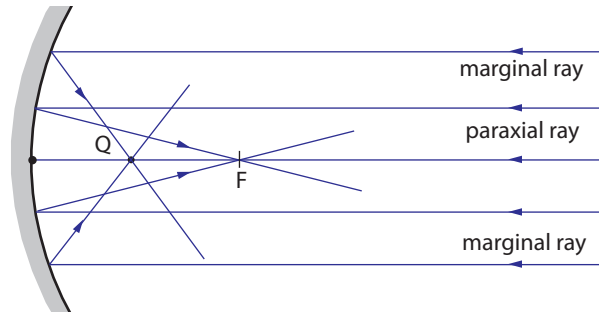

Fig. 1.11: Paraxial and marginal rays

The reflected marginal rays meet along the points of a curve called a caustic curve rather than at one point (Fig. 1.12). This usually happens when the mirror has wider aperture than its radius of curvature.

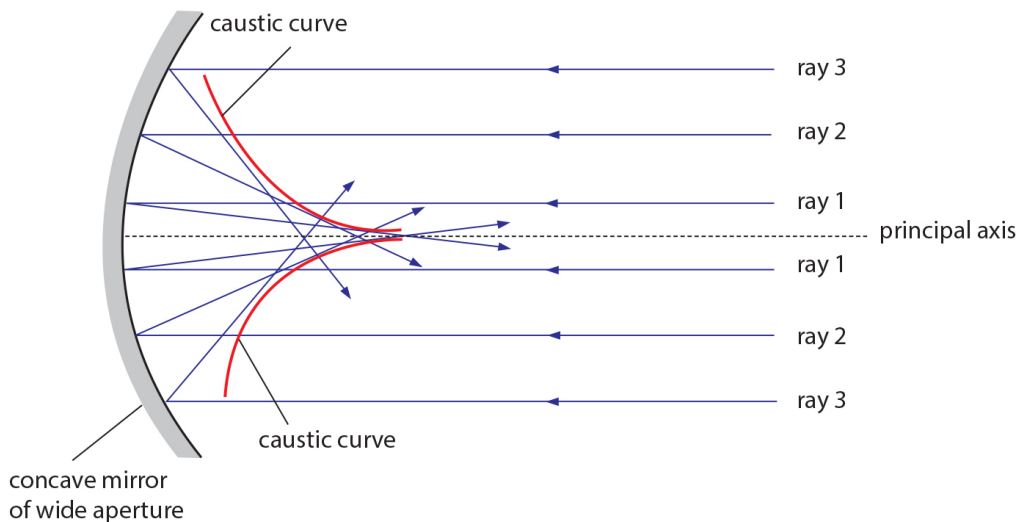

Fig. 1.12: Caustic curve

The formation of this caustic surface can be seen on the surface of a cup half full of tea, when light from one side is reflected on to the tea by the curved surface of the cup. The reflected rays produce a curve of light instead of a sharp spot of light on the surface of the tea.

This effect of the formation of a caustic curve in a concave mirror can be reduced by cutting off the marginal rays using a narrow slit. The slit should allow only the axial rays, closer to the principal axis (Fig 1.13).

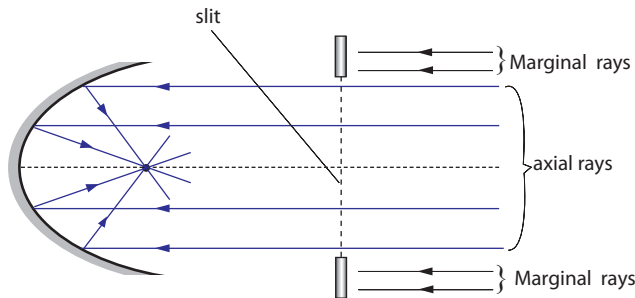

Fig. 1.13: Cutting off marginal rays reduces caustic curve

1.4 Image formation by spherical mirrors

1.4.1 Properties of images formed by a concave mirror

Activity 1.6

To determine the characteristics of images formed by concave mirrors

(Work in groups)

Materials: a concave mirror, a far away object (landscape, tree or any other), movable screen.

Steps

(a) Object at infinity

1. Place a concave mirror vertically and focus it onto a tree far away from the mirror.
2. Place a white screen facing the mirror.
3. Adjust the screen until you see a clear image of an object (landscape, tree or any other). How can you improve clarity of the image?
4. How does the size of the image compare with that of the object (tree)? Is it upright or inverted?
5. By referring to the image construction what can you say about the distance from the pole of the mirror and the screen? (Fig. 1.14).

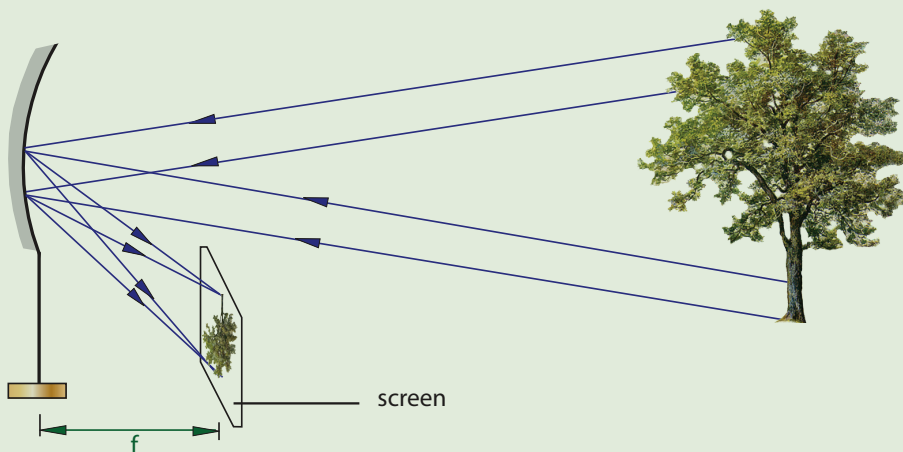

Fig. 1.14: Object at infinity

The image formed is inverted, real and diminished. The distance from the pole to the screen is nearly equal to the focal length, f , of the mirror. The image is formed on the focal plane.

(b) Object beyond C

1. Place a concave mirror of known focal length vertically.
2. With the help of a metre rule, mark the position of the pole, P, the principal focus, F, and the centre of curvature, C, on the table with a piece of chalk.
3. Place a lit candle along the principal axis of the mirror, away from C.
4. Place a white screen, as close as possible to the principal axis and adjust its position till a clear image is formed.
5. What is the size and nature of the image formed? Where is the image formed? (Fig. 1.15).

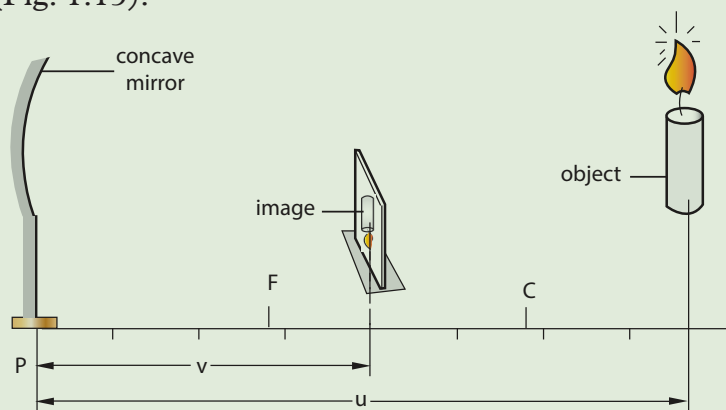

Fig. 1.15: Object beyond C

The image is formed between F and C and it is inverted, real and diminished.

(c) Object between F and C

1. Modify the experiment by carefully moving the candle closer to the mirror such that it is between F and C.
2. What are the characteristics of the image formed on the screen? (Fig. 1.16).

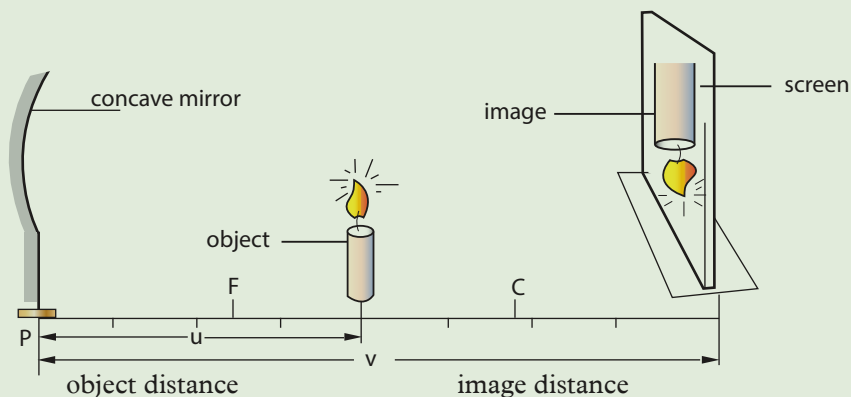

Fig. 1.16: Object between F and C

3. What happens to image distance when the object distance increases or decreases?
4. Modify the above experiment by keeping the candle close to the mirror, between P and F. Can you get an image on the screen? What are the other characteristics of the image?

The image is formed between F and C is beyond C and it is inverted, real and magnified.

As represented in Fig. 1.16, it is clear that as the object distance, u , decreases, (a) the image distance, v , increases and (b) the size of the image increases.

The image formed between P and F is virtual i.e. it cannot be projected on the screen. An enlarged, upright image can be seen in the mirror.

1.5 Locating images by constructing ray diagrams

The laws of reflection apply to both concave and convex mirrors. In curved mirrors the normal drawn at the point of incidence passes through the centre of curvature, C, as shown in Fig. 1.17 (a). The radius of curvature BC is the normal to the surface of the mirror at the point of incidence B. An incident ray AB parallel and close to the principal axis is reflected at B through F in a concave mirror (Fig.

1.17 (b)) such that, $\angle i = \angle r$. For a convex mirror, the reflected ray appears to come from F (Fig. 1.17 (c)) such that, $\angle i = \angle r$.

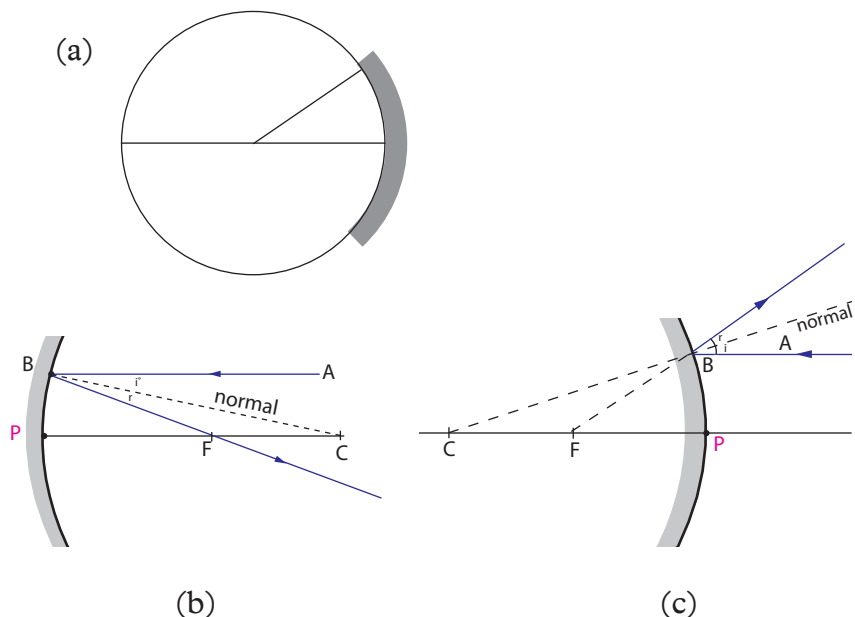

Fig. 1.17: Laws of reflection at curved surface

Images formed by curved mirror may be explained by use of ray diagrams. In a plane mirror, the image distance is always equal to the object distance. In curved mirrors, the image formed depends on the distance of the object from the mirror and the type of curved mirror being used. Ray diagrams are used to illustrate how and where the image is formed. The following rules will assist in the construction of ray diagrams.

Rule 1

The incident ray parallel and close to the principle axis converges through F (concave mirror) or appears to diverge out from F (convex mirror)(Fig. 1.18 (a), (b)).

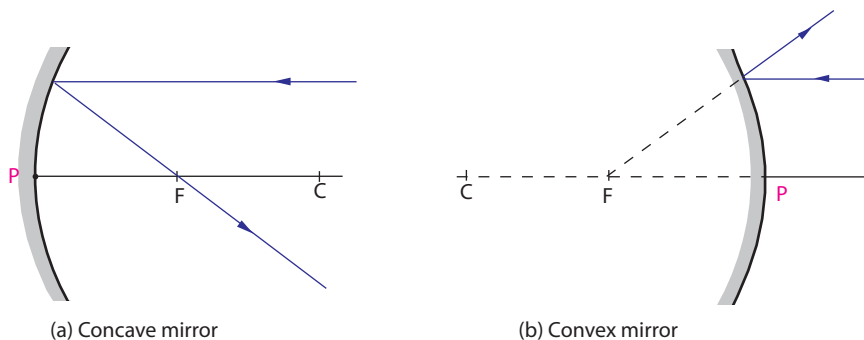

Fig. 1.18: Rays parallel and close to principle axis

Rule 2

The incident ray passing through the principal focus, F (concave) or appears to pass through F (convex) is reflected parallel to the principal axis (converse of rule 1). (Fig. 1.19 (a), (b)).

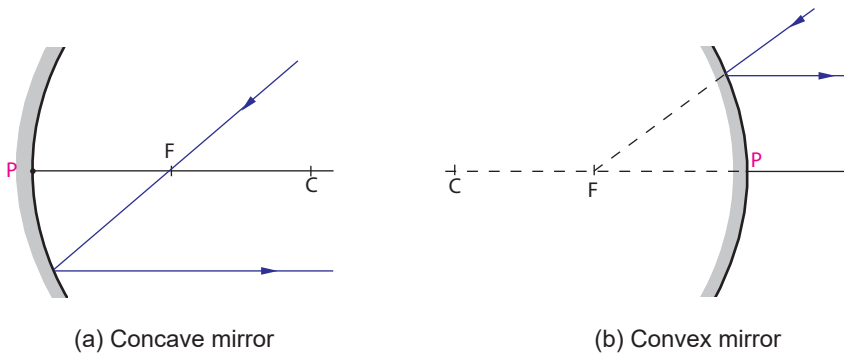

Fig. 1.19: Rays through principal focus

Rule 3

A ray passing through the centre of curvature, C (concave) or appears to pass through the centre of curvature C (convex), retraces its own path after reflection (Fig. 1.20(a), (b)).

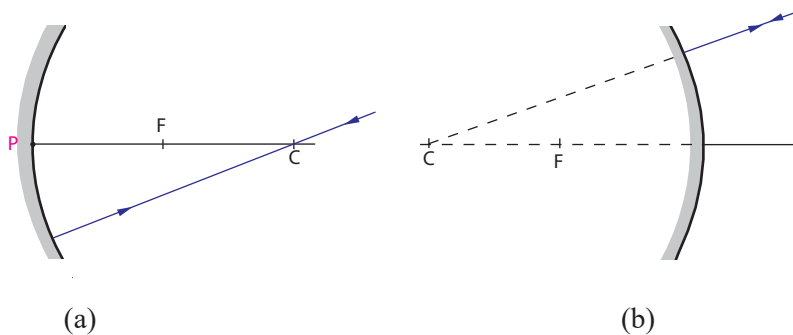

Fig. 1.20: Ray through the centre of curvature

It can be seen that if a ray passes through C and along the principal axis it will retrace its own path after reflection.

Rule 4

The angle of incidence is equal to the angle of reflection at the point of incidence (Fig. 1.21).

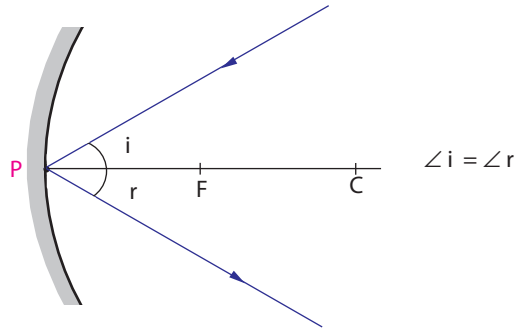

Fig. 1.21: Angles of incidence and reflection

To locate an image of an object we need a minimum of two incident rays from the object. From the rules of construction of ray diagrams, two incident rays can be chosen and the reflected rays drawn.

1.5.1 Concave mirror

Object far away from the mirror (at infinity)

Since the object is at infinity, all the rays from the object, incident on the mirror are almost parallel.

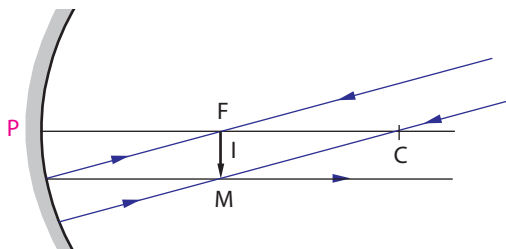

A diminished, real, inverted image is formed at F (Fig. 1.22).

Fig. 1.22: Object at infinity

Object OB beyond C

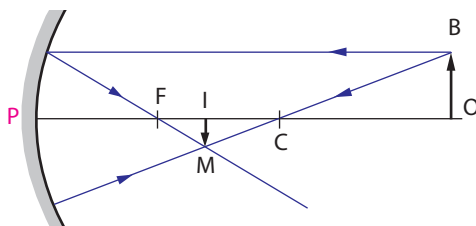

A diminished, real, inverted image is formed between F and C (Fig. 1.23).

Fig. 1.23: Object beyond C

Object OB at C

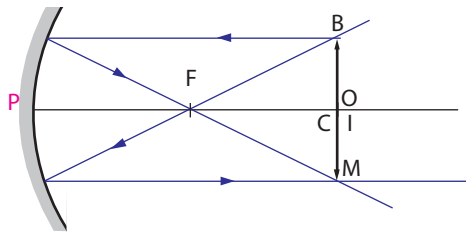

A real, inverted image of the same size is formed at C (Fig. 1.24).

Fig. 1.24: Object at C

Object OB between C and F

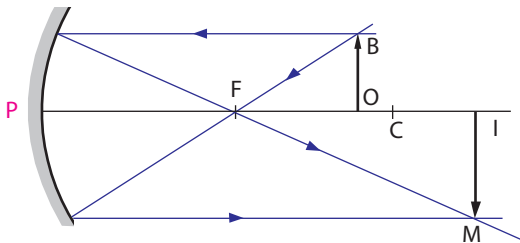

A real, inverted, magnified image is formed beyond C (Fig. 1.25).

Fig. 1.25: Object between C and F

Object OB at F

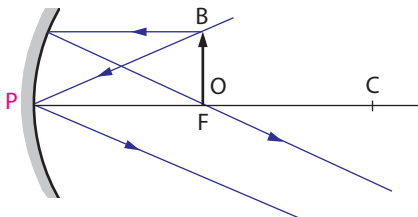

The image formed is at infinity, real, inverted and magnified. (Fig. 1.26)

Fig. 1.26: Object at F

Object OB between F and P

An enlarged, upright, virtual image is formed behind the mirror (Fig. 1.27).

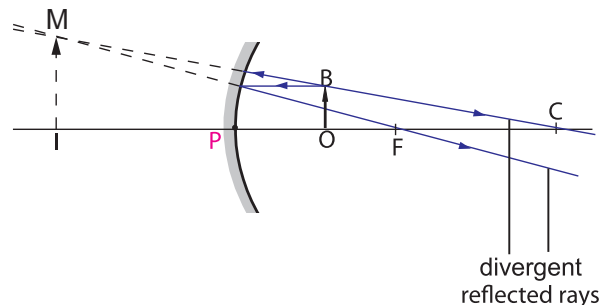

Fig. 1.27: Object between F and P

1.5.2 Convex mirror

For all the positions of the object OB , at measurable distances from the mirror, an upright, diminished, virtual image is always formed between P and F (Fig. 1.28). The real reflected rays do not converge at the side of the object. The virtual reflected rays always converge between F and P on the other side of the mirror.

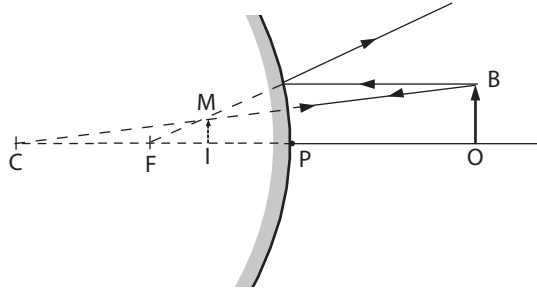

Fig. 1.28: Object measurable distance from convex mirror

Example 1.1

A concave mirror has a focal length of 3.0 cm and a real object 1.0 cm tall is placed at 4.0 cm from the pole of the mirror. By means of an accurate scale diagram, find the position of the image. What is the image distance from the pole?

Solution

Using rules 1, 3 and 4, three incident rays are drawn from B and the corresponding reflected rays from the concave mirror. The reflected rays converge at the point M , where the image of B is formed. The image of O is formed at I .

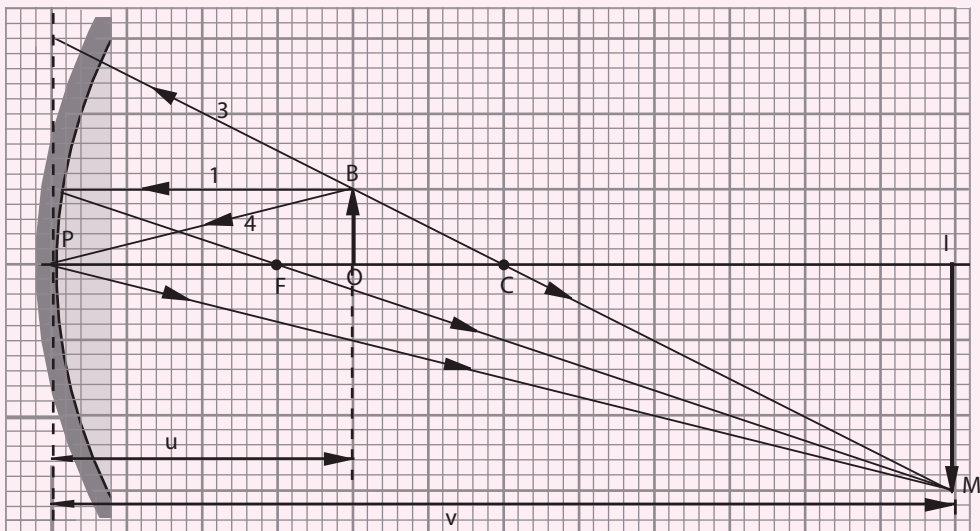

Fig. 1.29

IM is the real image formed at 12.0 cm from the mirror. In Fig. 1.29, $u = 4$ cm. is the object distance and $v = 12.0$ cm is the image distance from pole P.

1.6 Equations and magnification of curved mirrors

The ray diagrams only determine the image position, size and type of image formed of objects placed at a given location in front of a curved mirror. However, ray diagrams fail to provide information in a quantitative form. To obtain numerical information, we use mirror equation and magnification equation. The mirror equation expresses the quantitative relationship between the object distance (u), the image distance (v) and focal length (f).

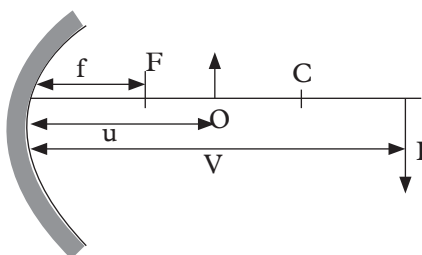

Fig. 1.30: Ray diagram

The mirror equation is
$$\frac{1}{f} = \frac{1}{u} + \frac{1}{v}$$

where f = focal length, u = object distance and v = image distance

Magnification equation relates the ratio of the image distance and object distance to the ratio of image height (h_i) and object height (h_o)

Magnification, $(m) = \frac{h_i}{h_o} = \frac{v}{u}$

where h_i = height of the image, h_o = height of the object, v = image distance and u = object distance.

Example 1.2

An object of height 4.0 cm is placed at a distance of 45.7 cm from a concave mirror whose focal length is 15.2 cm. Find:

- the image distance
- the size of the image

Solution

$$h_o = 4.0 \text{ cm} \quad f = 15.2 \text{ cm} \quad u = 45.7 \text{ cm}$$

$$(a) \quad \frac{1}{f} = \frac{1}{u} + \frac{1}{v}$$

$$\frac{1}{15.2} = \frac{1}{45.7} + \frac{1}{v}$$

$$\frac{1}{v} = 0.0658 - 0.0219$$

$$= 0.0439 \text{ cm}^{-1}$$

$$v = 22.8 \text{ cm}$$

$$(b) \quad m = \frac{v}{u} = \frac{h_i}{h_o}$$

$$\frac{22.8}{45.7} = \frac{h_i}{h_o}$$

$$\frac{h_i}{4} = \frac{22.8}{45.7}$$

$$h_i = \frac{22.8 \times 4}{45.7}$$

$$= 1.99 \text{ cm}$$

Example 1.3

A candle of height 8.0 cm is placed a distance of 16.0 cm from a concave mirror of centre of curvature 50.0 cm. Determine the image distance and the image size.

Solution

$$h_o = 8.0 \text{ cm} \quad u = 16.0 \text{ cm} \quad r = 50.0 \text{ cm}$$

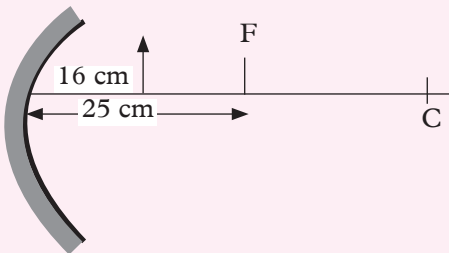

Fig. 1.31

$$\text{Since } C = 2f, f = \frac{50}{2} = 25.0 \text{ cm}$$

$$\frac{1}{f} = \frac{1}{u} + \frac{1}{v}$$

$$\frac{1}{25} = \frac{1}{16} + \frac{1}{v}$$

$$\frac{1}{v} = \frac{1}{25} - \frac{1}{16}$$

$$= 0.04 - 0.0625$$

$$\frac{1}{v} = -0.0225$$

$$v = -44.4 \text{ cm}$$

The negative value, means the image is virtual, therefore $v = 44.4$

$$m = \frac{h_i}{h_o} = \frac{v}{u}$$

$$h_i = \frac{v \times h_o}{u} = \frac{44.4 \times 8}{16} \text{ cm} \times 8 \text{ cm} = 22.2 \text{ cm}$$

The Positive (+) or (-) sign conventions

A negative or positive sign in front of a numerical value for a given quantity represents information about direction.

Quantity	Concave mirror	Convex mirror
f	+	-
v	+ real image - Virtual image	- virtual image
h_i	+ image upright (virtual) - Inverted (real)	+ image upright (virtual)

Example 1.4

An object of height 2 cm is placed 25 cm in front of a concave mirror. A real image is formed 75 cm from the mirror. Calculate the height of the image formed.

Solution

$$\begin{aligned} \text{Magnification, } (m) &= \frac{\text{image distance } (v)}{\text{object distance } (u)} \\ &= \frac{75 \text{ cm}}{25 \text{ cm}} = 3 \end{aligned}$$

$$\text{Also } m = \frac{\text{size of the image (IM)}}{\text{size of the object, (OB)}}$$

$$\therefore 3 = \frac{\text{IM}}{\text{OB}}$$

$$\text{IM} = 3 \times \text{OB} = 3 \times 2 = 6 \text{ cm}$$

The height of the image is 6 cm.

Example 1.5

An object placed 40 cm from a concave mirror produces a magnification of 1. Calculate the focal length of the mirror.

Solution

$$\text{Magnification, } m = \frac{IM}{OB} = \frac{v}{u} = 1$$

Since $IM = OB$, hence $v = u$

The object is at C and the image is at C.

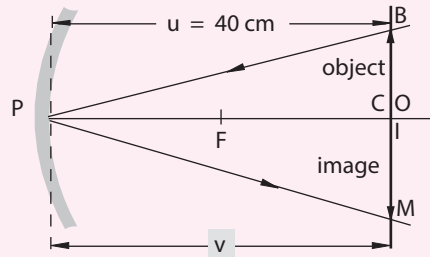

Fig. 1.32

$$PC = r = 2f = u = v = 40 \text{ cm}$$

$$2f = 40 \text{ cm.}$$

$$\therefore f = 20 \text{ cm}$$

The focal length of the mirror is 20 cm

1.7 Applications of curved reflecting surfaces

(a) Concave mirrors

Concave mirrors are used as reflectors. Here are some of the applications of concave mirrors.

(i) Cinema projector

A concave mirror is placed behind a source of light. The light rays travelling in the backward direction which would, otherwise, have been lost, get reflected from the mirror and increase the intensity of light reaching the film or a transparent slide to be projected on a screen (Fig. 1.33).

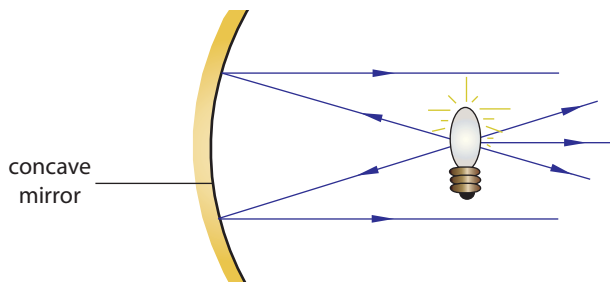

Fig. 1.33: Concave mirror in a cinema projector

(ii) Medical uses

Doctors who examine the ear, nose or throat of persons (ENT specialists) use a concave mirror fitted with a bulb at its principal focus. Light from the bulb is made to fall upon the concave mirror and the reflected light, as a sharp narrow beam, is incident upon the area to be examined.

(iii) Parabolic mirrors

Concave parabolic mirrors are used in search lights where a powerful luminous source of light is placed at the principal focus of the mirror. The reflected rays form a parallel beam of light and travel a long distance. Car headlights, head lamps or hand torch light (or flash light) use the same principle.

(iv) Astronomical telescopes

One of the most important uses of concave mirrors is in the construction of large astronomical telescopes used to examine heavenly bodies like the stars. A big concave mirror of diameter of about 5 m or more collects light rays from a star and forms the image at its principal focus. Distant stars which cannot be seen with an unaided eye become clearly visible through the telescope.

(v) Parabolic dish collectors

Parabolic dish collectors called the solar concentrators (Fig. 1.34) use large parabolic mirrors to concentrate the sun's rays on to a small area at their focus to produce very high temperature.



Fig. 1.34: Solar concentrator

(vi) Parabolic dish aerial

In radio communication, a parabolic dish aerial (Fig. 1.35) is used. By a suitable arrangement radio waves are reflected as unidirectional parallel waves.

Convex mirror helps us to see the objects lying in a limited area (smaller). However convex mirrors have the disadvantage that they do not give the correct distance

of the vehicle behind, as the image distance (v) is smaller than the object distance (u). Large convex mirrors are also used in supermarkets, underground parking areas etc. to cover a wider field of view to be observed.



Fig. 1.35: Parabolic dish aerial.

(vii) Shaving mirror

A concave mirror is used as a shaving or a make-up mirror. The mirror is placed at a distance less than its focal length, from the face. A virtual upright, magnified image of the face is seen in the mirror (Fig. 1.36).

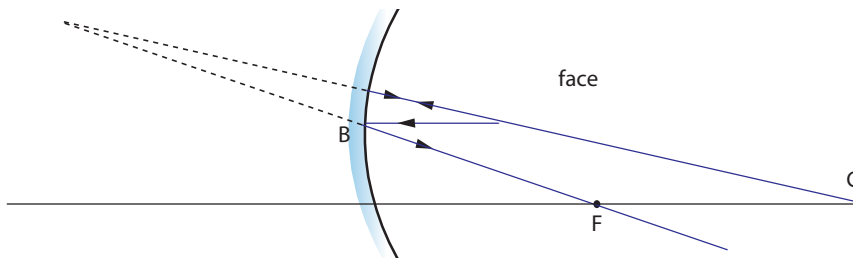

Fig. 1.36: Shaving mirror.

(b) Convex mirrors

A convex mirror is used as a rear view driving mirror. Any object in front of the mirror, i.e., lying behind the car, forms an upright diminished virtual image between F and P (Fig. 1.37). For example, another car behind is seen upright and small in size in the mirror. The driver of a car has a wider view of all the objects lying behind.

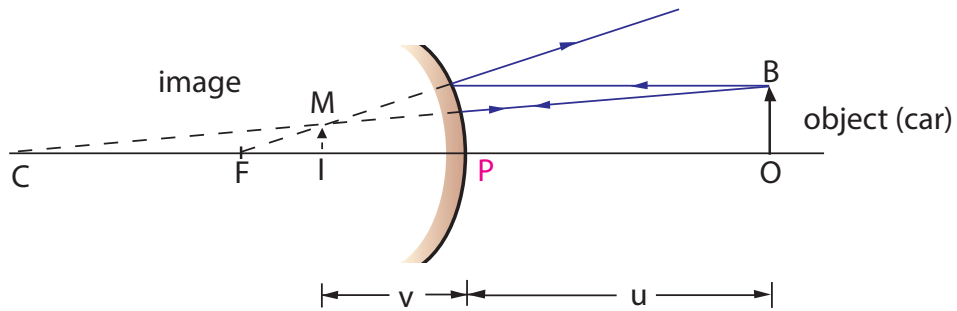

Fig. 1.37: Rear view driving mirror.

A convex mirror covers a wider field of view so that the light rays from a wide angle can be observed. A plane mirror of the same size as the convex mirror helps us to see the objects lying in a limited area (smaller).

1.8 Project work

Construction of a solar concentrator

Suggested materials: Mild steel wires of about 3 mm in thickness, aluminium foil, superglue

Assembly

1. Cut the mild steel wire so as to make three circles of diameter 1.0 m each.
2. Make the three circles using the wire.
3. Weld the wires to form a spherical framework.

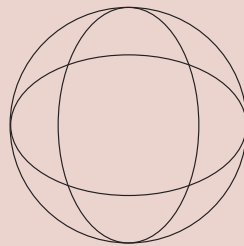

4. Cover the framework using the aluminium foil.
5. Cut the framework to produce two equal $\frac{1}{2}$ sphere.

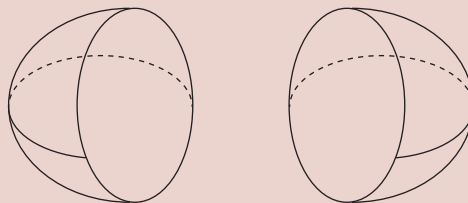

6. Mount one of the $\frac{1}{2}$ sphere on a stand such that it can be rotated in all directions.

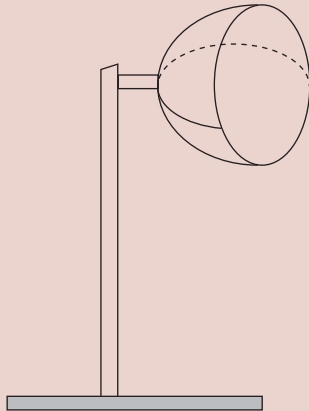

7. Using a thicker mild steel wire, make a framework that will be able to support a small saucepan and connect it to the framework above. Make sure that the sauce pan is at $\frac{1}{2}$ centre of the sphere i.e. at focal point.

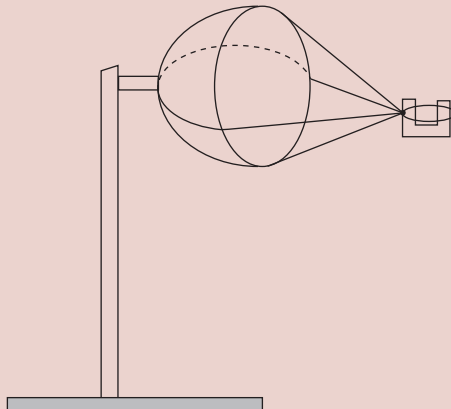

8. Direct the $\frac{1}{2}$ sphere and the sauce pan towards the sun.
9. Fill the sauce pan with water at 15 minutes interval.
10. Measure the temperature at 15 minutes interval.

Such an arrangement is called a **solar concentrator**.

Topic summary

- The reflecting surface of a plane mirror is a straight plane, concave mirror curves in, convex mirror curves outwards and parabolic mirror is a section of a paraboloid.
- The centre of the reflecting surface is the **pole, P**, of a curved mirror.
- The **centre of curvature, C**, of a curved mirror is the centre of the sphere of which the mirror forms a part.
- The **principal axis** of a curved mirror is a line passing through the pole, P, and the centre of curvature, C.
- The **radius of curvature, r**, of a curved mirror is the radius of the sphere of which the mirror forms a part.
- The **principal focus, F**, is a fixed point on the principal axis where a set of incident rays parallel and close to the principal axis converge in a concave mirror and appear to diverge on in a convex mirror.
- The principal focus is real for a concave mirror and virtual for a convex mirror.
- The **focal length, f**, of a curved mirror is the distance from its pole to the principal focus.
- Focal length of a concave mirror is half the radius of curvature of the mirror.
- A parabolic concave reflector has a single point focus and the caustic curve is not formed.
- Curved mirrors obey the laws of reflection just like plane mirrors.
- The **focal length, f**, of a curved mirror is half the radius of curvature, r.
- **Magnification (m)** is defined as the ratio of the height of the image to the height of the object.

$$\text{Magnification} = \frac{\text{height of image (IM)}}{\text{height of object (OB)}} = \frac{\text{image distance (v)}}{\text{object distance (u)}}$$

$$m = \frac{\text{IM}}{\text{OB}} = \frac{v}{u}$$
$$\frac{1}{f} = \frac{1}{u} + \frac{1}{v}$$

- The nature, size and the position of the image formed in a concave mirror depends on the position of the object in front of the mirror. See the Table 1.1 below.

Table 1.1

Object	Image	Nature of image	Size of image compared to object
At infinity (far away)	F	Real and inverted	Diminished
Beyond C	Between F and C	Real and inverted	Diminished
At C	At C	Real and inverted	Same size
Between C and F	Beyond C	Real and inverted	Magnified
At F	At infinity (far away)	Real and inverted	Magnified
Between F and P	Behind the mirror	Virtual and upright	Magnified

- In a convex mirror, for all the positions of the object at a measurable distance from the mirror, an upright, diminished, virtual image is always formed between F and P.
- Cinema projectors, search lights, car head lights, astronomical telescopes, solar concentrators, dish aerials are a few applications of curved reflecting surfaces.

Topic Test 1

1. The focal length of a curved mirror is the distance between
 - A. the principal focus and the centre of curvature.
 - B. the pole of the mirror and the centre of curvature.
 - C. the pole of the mirror and the principal focus.
 - D. the object and the image.
2. In a curved mirror, how is the focal length (f) related to the radius of curvature (r) of the mirror?
 - A. $f = \frac{r}{2}$
 - B. $f = 2r$
 - C. $f = r$
 - D. None of the above.
3. In a concave mirror, when the object is placed between the principal focus and the pole, the image formed is
 - A. real and diminished
 - B. real and magnified
 - C. virtual and upright
 - D. virtual and inverted
4. In a concave mirror, when the object is placed at 12 cm from the pole a real image is formed at 36 cm from the pole of the mirror. The magnification produced by the mirror is
 - A. 0.25
 - B. 4.00
 - C. 0.33
 - D. 3.00
5. The effect of formation of a caustic curve in a concave mirror can be minimized by
 - A. cutting off the marginal rays.
 - B. cutting off the axial rays.
 - C. cutting off all the rays parallel to the principal axis.
 - D. cutting off the rays passing through the centre of curvature of the mirror.
6. In a convex mirror, the image formed is always
 - A. real and upright.
 - B. virtual and upright.
 - C. real and inverted.
 - D. virtual and inverted.
7. In a concave mirror, when a real object is placed at $2f$ (Fig. 1.38), the image formed will be
 - A. at infinity.
 - B. between p and f .
 - C. between P and $2f$.
 - D. at $2f$.

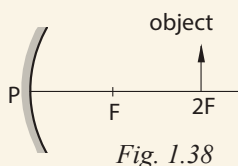

9. Describe a parabolic mirror. What is the advantage of a parabolic mirror over a spherical concave mirror.
10. Define the following terms: pole, principal axis, principal focus, focal length, focal plane in relation to a concave mirror.
11. Copy and complete the following diagrams (Fig. 1.39 (a) to (d)) to show the path of the reflected rays.

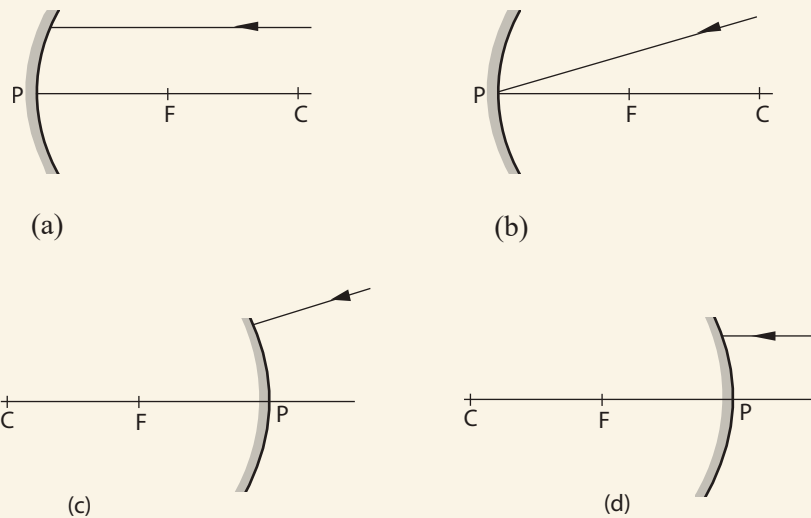

Fig. 1.39

12. A concave mirror has a focal length of 6 cm and an object 2 cm tall is placed 10 cm from the pole of the mirror. By means of an accurate ray diagram, find the position and size of the image formed. Is the image real or virtual? Explain your answer.
13. Describe an experiment to determine the magnification of an image in a concave mirror.
14. Fig. 1.40 shows the graph of real image distance v against the object distance u for a concave mirror.

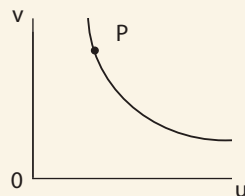
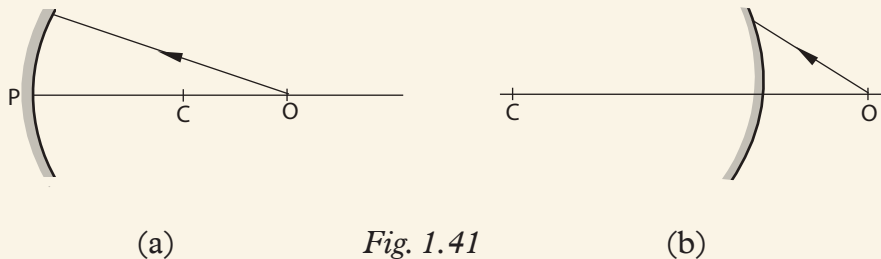

Fig. 1.40

Explain why the coordinate P is for a magnified image.

15. (a) Define magnification.

- (b) An object of height 3 cm is placed at 20 cm in front of a concave mirror. The real image formed is 10 cm from the pole of the mirror. Calculate the height of the image formed.
16. A concave mirror has a focal length of 6 cm and a real object 3 cm tall is placed 15 cm from the pole. Calculate the distance of the image from the pole if the size of the image is 2 cm.
17. Explain, with the aid of a neat ray diagram how a concave mirror can be used as a 'make-up' mirror. (The object may be represented by an arrow-head).
18. Motorists use a convex mirror, rather than a plane mirror, as a rear-view mirror. State one advantage and one disadvantage of using a convex mirror.
19. Name the type of mirror used in the following:
- car head lights.
 - solar concentrators.
 - underground car parking area.
20. For the following Figure 1.41 (a) and (b), copy and complete the ray diagram to locate the position of the point image I for the point object placed at O.



21. The graph (Fig. 1.42) shows how the image distance v and the object distance u vary for a concave mirror.

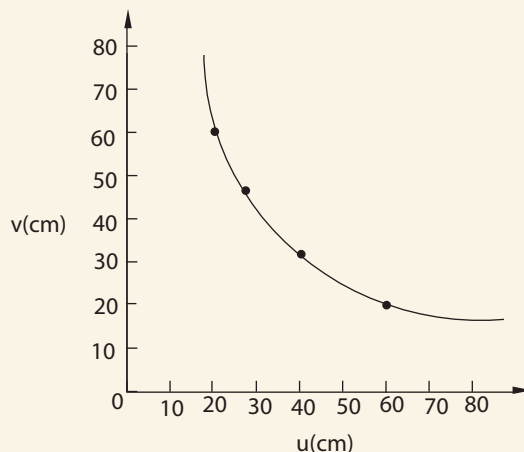

Fig. 1.42

- (a) When the object is placed at a distance of 60 cm from the mirror

- (i) what is the distance of the image from the mirror?
 - (ii) Is the image magnified, diminished or the same size as the object?
 - (iii) what is the magnification produced by the mirror?
- (b) The object is now moved until it is 20 cm from the mirror.
State and explain what happens to
- (i) the image distance.
 - (ii) the magnification produced by the mirror.

22. A man uses a shaving mirror with a focal length of 72 cm to view the images of his face. If his face is 18 cm from the mirror, determine the image distance and the magnification of his face.
23. The real image produced by a concave mirror is observed to be six times longer than the object when the object is 34.2 cm in front of a mirror. Determine the radius of curvature of this mirror.
24. An object and a concave mirror are used to produce a sharp image of the object on the screen. The table below shows the magnification and image distance of the object.

Magnification m	0.25	1.5	2.5	3.5
Image distance v (cm)	20	40	56	72

Table 1.2

- (a) Plot a graph of m against v
- (b) Use the graph to find:
 - i. The image distance when $M=1.0$
 - ii. The object distance
 - iii. The focal length of the mirror

Unit Outline >>>

- Definition of a lens
- Types of lenses
- Terms used in thin lenses
- Image formation by converging and diverging lenses
- The lens formula
- Sign convention
- Magnification
- Power of lenses
- Defects of lenses
- Simple telescope

Introduction

In secondary 1, we learnt about refraction of light through a medium. In this topic, we are going to specifically focus refraction in thin lenses. How the thin lenses are applied in optical instruments such as microscope, glasses, cameras and others.

2.1 Definition of a lens

Activity 2.1

What is a lens?

(Work in pairs or in groups)

Materials

- Water
- Retort stand
- Round bottomed flask
- Sun
- Plain paper
- Magnifying lens

Steps

1. What is a lens?
2. Fill a volumetric flask with clear water.
3. Cork the flask.
4. Tilt the flask such that the neck of the cork is horizontal.
5. Place a source of light (sun, bulbs) above the flask.

6. Place a white paper under the flask preferably on the ground.
7. Move the flask to or away the white paper.
8. What happens on the plain paper?
9. Discuss the results in your groups.
10. Replace the round bottomed flask with a magnifying lens. What happens to the paper? Explain.

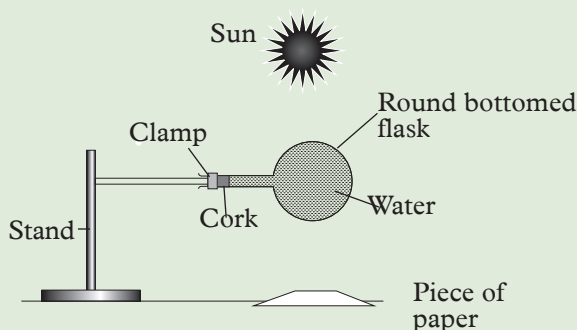

Fig. 2.1

A lens is a transparent medium bounded by two spherical surface or a planed curved surface.

2.2 Types of lenses

Activity 2.2

To identify and describe types and shapes of lenses

(Work in groups)

Materials

- Charts showing converging and diverging beam through lens.
- Convex lenses
- Plane lenses
- Spherical lenses

Steps

1. Place some lenses available in your school on a labeled white plane paper. Trace their outlines. What is the shape of the lenses?
2. Feel the lenses in Fig. 2.2 below with your fingers. What do you feel? What are their shapes? Why do you think they are made in such shapes?

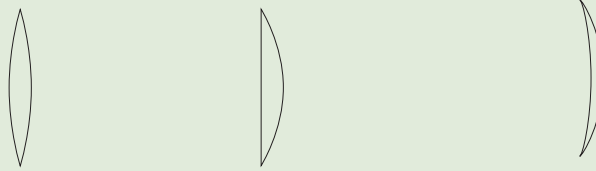

Fig. 2.2

3. Name the above lenses.
4. Identify the lenses in Fig. 2.3 below. What are their shapes? Why do you think they are made in such shapes? Name them.

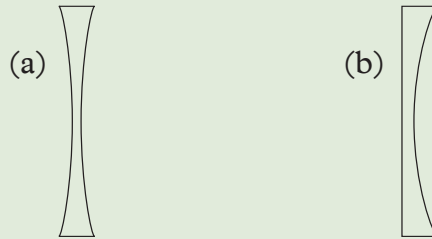

Fig. 2.3: Types of concave lenses

There are two main groups of lenses. A type that is thick in the middle and thin at the edges, causing rays of light to converge. This is called **converging** or **convex lenses**. The other type is thin in middle and thick at the edges causing the rays of light to diverge. This lens is called **diverging** or **concave lens**.

Concave lenses are of different shapes as shown in Fig. 2.4.

A **bi-convex** or **double convex** lens has both its surfaces 'curving out'. (Fig. 2.4).

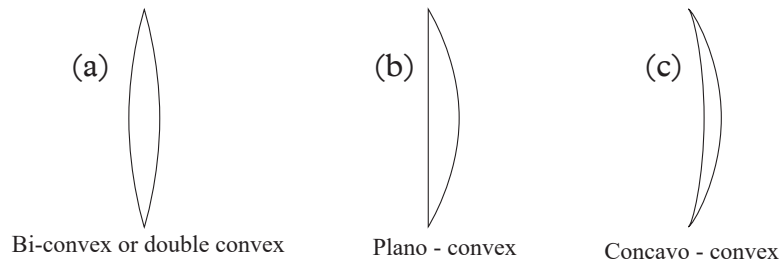

Fig. 2.4: Types of convex lenses

Concave lenses are also of different shapes (See Fig. 2.5)

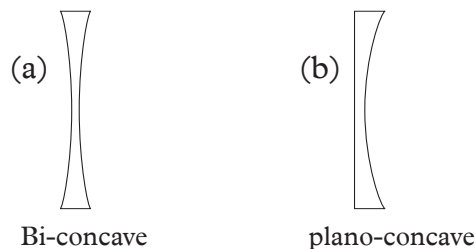

Fig. 2.5: Types of lenses

A *bi-concave* or *double concave* lens has both its surfaces ‘curving in’. Other concave lenses are *plano-concave* and *convexo-concave* or diverging meniscus (Fig. 2.5).

When a beam of light is incident on the lenses, rays tend to converge at a point when they pass through a convex lens and diverge through a concave lens. (Fig. 2.6)

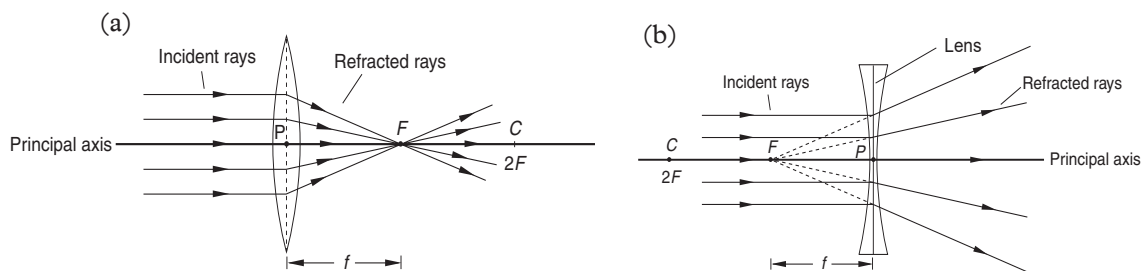

Fig. 2.6: Refraction of light through lenses

2.3 Terms used in thin lenses

Activity 2.3

To find out the meaning of the terms used in thin lenses

(Work in pairs or in groups)

Materials

- Magnifying lens
- Double convex lenses
- Sunshine
- Piece of paper

Steps

1. This activity is done outside the classroom during daylight.
2. Place a dry tissue paper (or dry leaves) on a flat open ground.
3. Place the lens on the tissue paper.
4. Slowly lift the lens upwards away from the paper until a spot of light is formed on the paper.



Fig. 2.7: Burning a paper using a lens

5. Hold the lens at this position for some time.
6. Observe what happens to the paper. Explain why the paper burns.
7. Repeat the activity with a concave lens. What do you observe? What happens to the beam of light?

The paper starts to burn. This shows that a convex lens brings to a focus point light energy from the sun and since light is in form of energy, a lot of it is concentrated at a point. This point where the rays are brought together after passing through the convex lens is called **principal focus**. This point is **real**.

When the activity is repeated with a concave lens, nothing happens. That means the principal focus of a concave lens is virtual.

The following are other common terms used in thin lenses:

(a) The centre of curvature (C)

The centre of curvature of the surface of a lens is the *centre of the sphere* of which the lens forms a part (Fig. 2.8 (a) and (b)). For each spherical lens there are two centres of curvature (C_1, C_2) due to the two curved surface.

(b) The radius of curvature (r)

The radius of curvature of the surface of a lens is the *radius of the sphere* of which the surface forms a part (Fig. 2.8 (a) and (b)). Each surface has its own radius of curvature (r_1 or r_2).

(c) Principal axis

The principle axis of a lens is a line passing through the two centres of curvature (c_1 and c_2) as shown in Fig. 2.8.

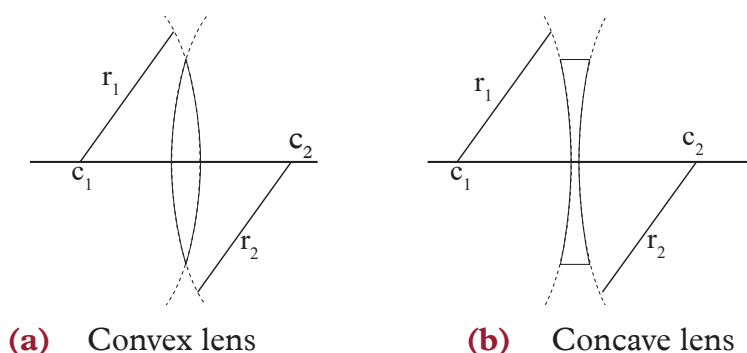

Fig. 2.8: Principal axis

(d) The principal focus

A prism always deviates the light passing through it towards its base. A convex lens may be regarded as being made up of large portions of triangular prisms as

shown below. The emergent beam, therefore, becomes convergent in a convex lens (Fig. 2.9 (a)). The reverse is the effect in a concave lens (Fig. 2.9(b)).

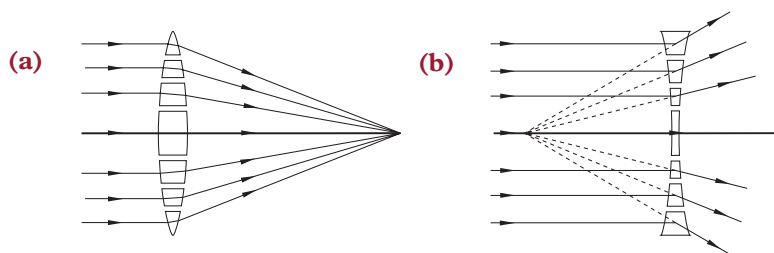

Fig. 2.9: Action of lenses compared with prisms

(i) Principal focus of a convex lens

Consider a set of incident rays parallel and close to the principal axis of a convex lens (Fig. 2.10). These rays, after refraction through the lens, pass through point F on the principal axis. Since all the rays converge at this point, it is called *principal focus*. Since this point can be projected on a screen, it is said to be a *real principal focus*.

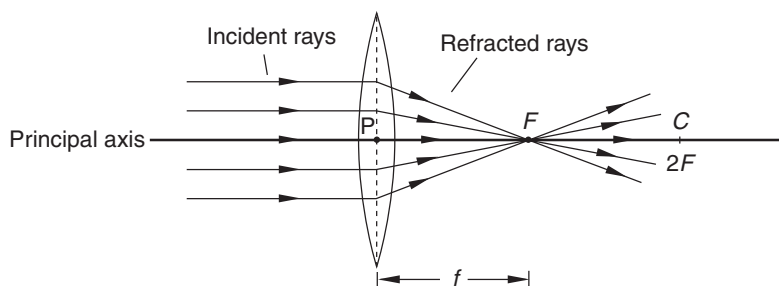

Fig. 2.10: Principal focus on a convex lens

(ii) Principal focus of a concave lens

For a set of incident rays parallel and close to the principal axis of a concave lens, the refracted rays appear to diverge from a fixed point on the principal axis. This point is called the *principal focus* F , of a concave lens (Fig. 2.11). This principal focus is virtual since it cannot be projected on a screen.

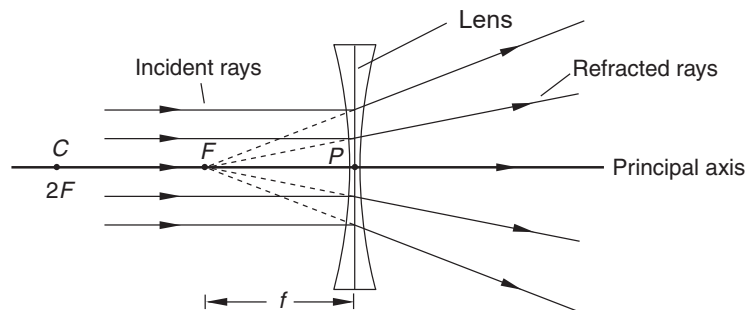

Fig. 2.11: Principal focus on a concave lens

(e) The focal plane

When a set of parallel rays are incident on a convex lens at an angle to the principal axis, as shown in Fig. 2.12, the refracted rays converge to a point, on a line passing through F and perpendicular to the principal axis. The plane passing through F is the *focal plane*.

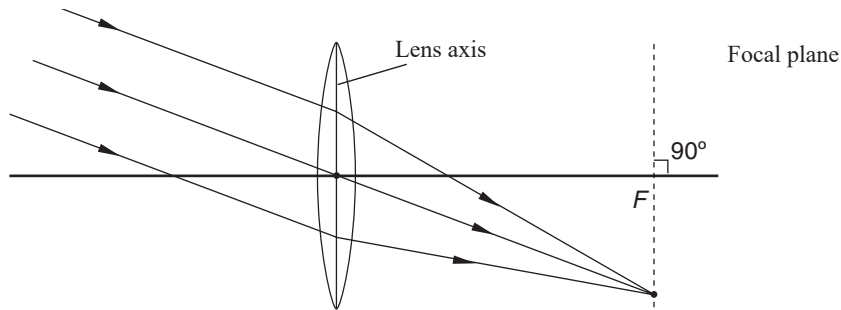

Fig. 2.12: Focal plane of a convex lens

(f) The optical centre (P)

The *optical centre* of a lens is a point which lies exactly in the middle of the lens ($PA = PB$) as shown in Fig. 2.13(a) and 2.13(b). Light rays going through this point go straight through without any deviation or displacement.

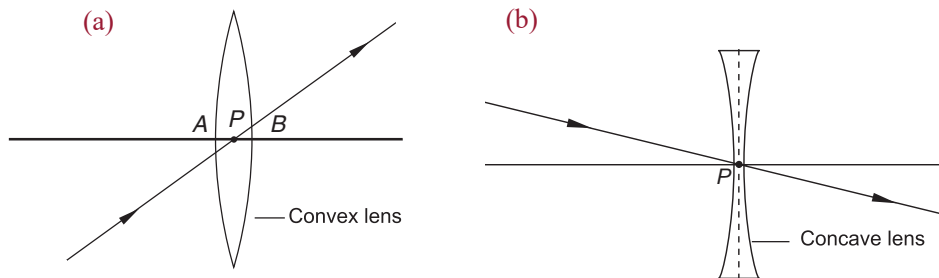

Fig. 2.13: Optical centre of a convex and concave lenses

(g) The focal length of a lens (f)

This is the distance from the optical centre to the principal focus of the lens (see Fig. 2.10(a) and 2.11(b)). Biconvex and biconcave lenses have a focal length on each side of the lens.

The concept of centres of curvature of the surfaces is required only in drawing the principal axis. Otherwise these points are referred to as $2F$, as they are situated at a distance twice the focal length from the centre of the lens ($PC = 2PF$).

Exercise 2.1

1. Distinguish between converging and diverging lenses.
2. Define the following:
 - (a) Principal axis
 - (b) Optical centre
3. Differentiate between the principal focus of the concave and convex lens.
4. How many principal foci does a biconcave lens have?

2.4 Image formation by converging lenses

Activity 2.4

To find out and describe the image formed by converging lenses

(Work in groups)

Materials

- Convex lenses
- Tree, Screen (white wall can act as screen)

Steps

1. Place a convex lens between a screen and a far away object e.g. a candle. (See fig 2.14).
2. Adjust the distance between the lens and the screen until the image of the candle is observed on the screen.

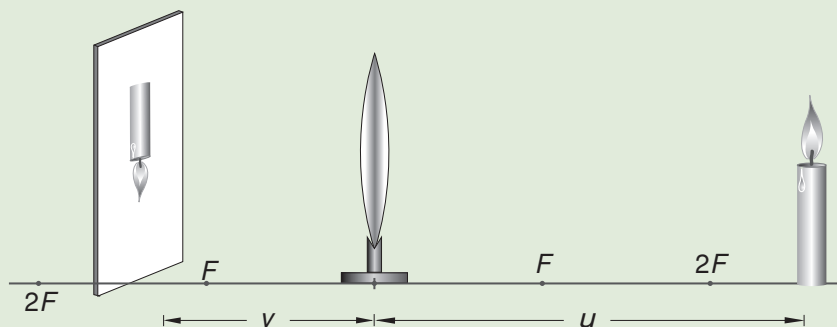

Fig. 2.14: Image formation by a far object

3. What are the characteristics of the image formed?
4. In groups, discuss the formation of the image using ray diagrams.

Ray diagrams are used to illustrate how and where the image is formed. The following are the important incident rays and their corresponding refracted rays used in the construction of ray diagrams.

Ray 1: A ray of light parallel and close to the principal axis, passes through the principal focus F (Fig. 2.15).

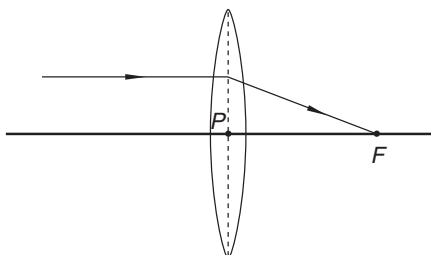

Fig. 2.15: Ray 1

Ray 2: A ray of light through the principal focus F emerges parallel to the principal axis after refraction (Fig. 2.16).

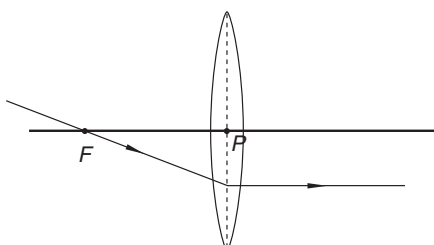

Fig. 2.16: Ray 2

Ray 3: A ray through the optical centre, P is undeviated after refraction through the lens (Fig. 2.17).

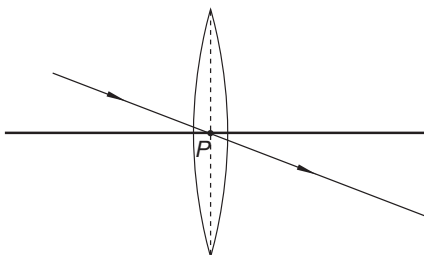

Fig. 2.17: Ray 3

2.5 Locating images by simple ray diagrams and describing their characteristics

To locate the image of an object, we need a minimum of two incident rays from the object. From the three standard rays discussed above, any two incident rays and their corresponding refracted rays can be drawn to locate the image. If the refracted rays converge, a *real image* is obtained. If the refracted rays diverge, then a virtual image is obtained.

2.5.1 Convex lens

Activity 2.5

To design and describe the characteristics of images formed by convex lenses when the object is at infinity

(Work in groups)

Materials

- White screen
- An object at infinity (landscape or a tree)
- Lens
- Metre rule

Instructions

1. In this activity, you will design and carry out an investigation to describe the characteristics of images formed by convex lenses when the object is at infinity.
2. Modify the set-up, we used in Activity 1.6 with materials provided to you. Sketch the new set-up.
3. Write a brief procedure for your investigation. Conduct the investigations. Draw the image formed.
4. Describe its characteristics.
5. Suggest some possible sources of errors in your investigation and explain how they can be minimised. Write a report and present it in a class discussion.



Note: The distance from the centre of the lens to the screen is nearly equal to the focal length, f , of the lens.

(a) Object far away from the lens (at infinity)

Since the object is at infinity, all the rays from the object, incident on the lens are almost parallel. The refracted rays converge at a point on the focal plane, as shown in Fig. 2.18.

Image characteristics

A *diminished, real, inverted* image is formed at F .

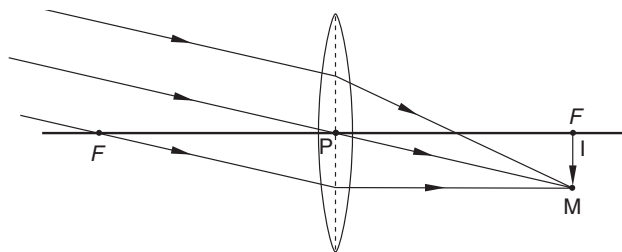

Fig. 2.18: Object OB at infinity

(b) Object OB just beyond C ($2F$)

Activity 2.6

To describe images formed by convex lens when the object is beyond $2F$ and at $2F$

(Work in groups)

Materials

- Screen
- Lens
- Candle

Steps

1. Mark the positions of the principal focus F and $2F$ on both the sides of the lens with a piece of chalk.
2. Place a lit candle on the table along the principal axis of the lens, slightly away from $2F$.
3. Place a white screen, on the other side of the lens, perpendicular to the principal axis of the lens and adjust its position to and fro to the screen and observe what happens. What are the characteristics of the image formed?

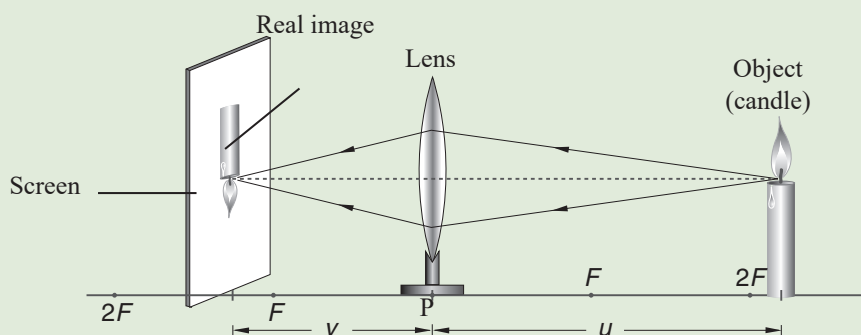

Fig. 2.19: Object beyond $2F$

4. Repeat step 3 by placing the candle at $2F$ and observe what happens. What are the characteristics of the images formed?

Fig 2.20 shows the ray diagram to locate the images when the object is beyond C.

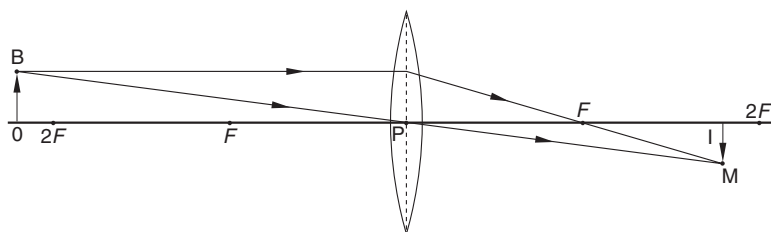

Fig. 2.20: Object OB just beyond $2F$

Image characteristics

A *diminished, real, inverted* image is formed between F and $2F$.

(c) Object OB at $2F$

The ray diagram when the object (candle) was placed at $2F$ is as shown in Fig. 2.22 below.

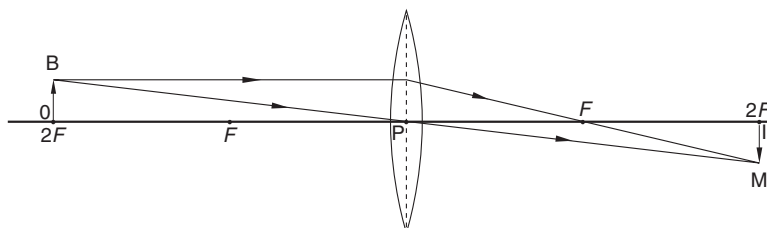

Fig. 2.21: Object OB at $2F$

Image characteristics

A *real, inverted* image of the *same size* as the object is formed at $2F$.

(d) Object OB between $2F$ and F

Activity 2.7

To design and describe the images formed by convex lens when the object is between F and $2F$ and at F

(Work in groups)

Materials

- Candle
- Lens
- Screen

Instructions

1. Modify the set-up as used in Activity 2.6 by placing the candle between $2F$ and F .
2. Draw the set-up.
3. Write a brief procedure for your investigation. Carry out the investigation and describe the characteristics of the images formed.
4. Suggest some possible sources of errors in your investigation and explain how they can be minimised.
5. Write a report and present it to a class.

The simple ray diagram when the object is between F and $2F$ is as shown in Fig. 2.22.

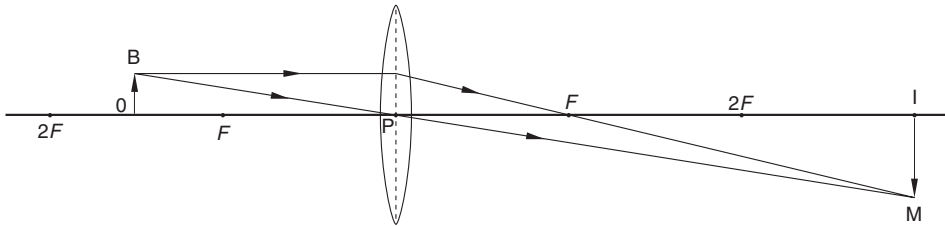

Fig. 2.22: Object OB between $2F$ and F

Image characteristics

A *real, inverted and magnified* image is formed beyond $2F$

(e) Object OB at F

When the object was at F , the refracted rays are nearly parallel and converge at infinity as shown in Fig. 2.23 below.

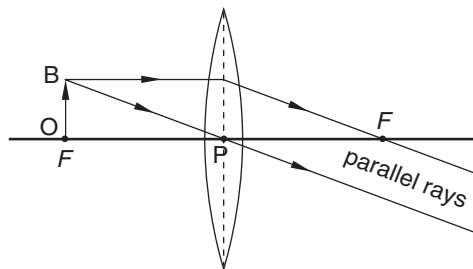

Fig. 2.23: Object OB at F

Image characteristics

A *real, inverted, magnified* image is formed far away from the lens i.e. at infinity. (cannot be described)

(f) Object OB between F and P

Activity 2.8

To describe the image formed by convex lens when the object is between F and P

(Work in groups)

Materials

- Candle
- Lens
- Screen

Steps

1. Repeat Activity 2.7 keeping the candle close to the lens, between F and P . Can you get an image on the screen? Describe its characteristics.

2. Is the image real or virtual?
3. Where is the image formed?
4. Explain your observations.

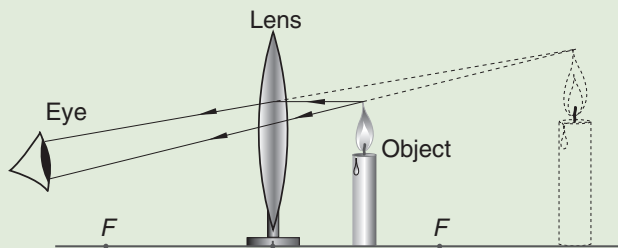

Fig. 2.24: Object between F and P

The image formed is virtual and cannot be projected on the screen. An enlarged, upright image can be seen through the lens on the same side with the object (Fig. 2.24) above.

A simple ray diagram to locate the image when the object is placed between F and P is as shown in Fig. 2.25 below.

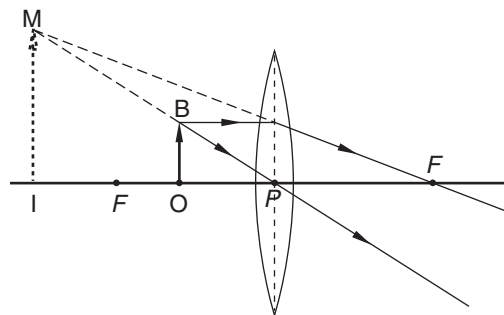

Fig. 2.25: Object OB between F and the lens.

Image characteristics

A *magnified, upright and virtual* image is formed on the same side as the object.

2.5.2 Concave lens

When the object is at infinity, an upright, diminished and virtual image is formed at principal focus F . For all other positions of the object OB , an upright, diminished, virtual image is always formed between F and P (Fig. 2.26).

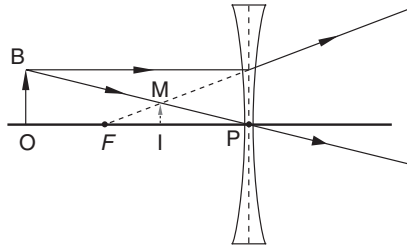

Fig. 2.26: Image formation by a concave lens.

Example 2.1

A convex lens has a focal length of 2 cm and a real object 6 cm tall is placed 18 cm from the centre of the lens. By means of an accurate scale diagram, find the position, size and nature of the image formed.

Solution

Using rays 1 and 3 of the image construction, two incident rays are drawn from B and the corresponding refracted rays through the lens. The refracted rays converge at M where the image of B is formed.

Scale chosen for object and image values: 1 cm = 6 cm.

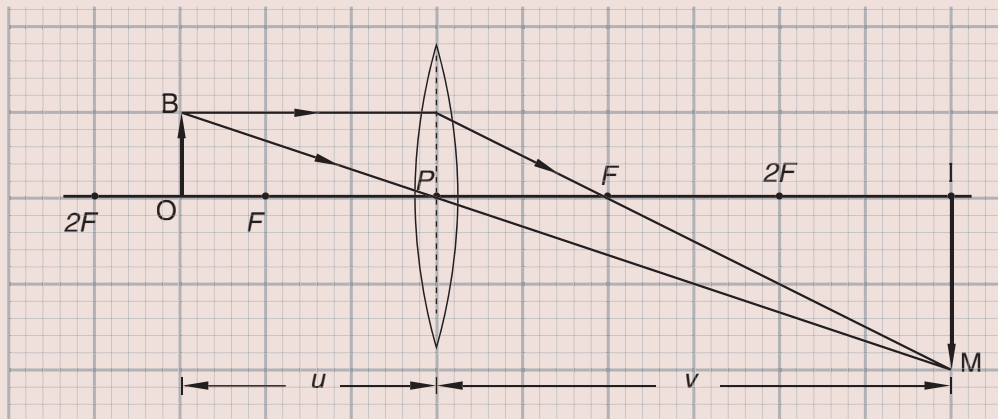

Fig. 2.27: Graphical construction of images formed by convex lens

The image of O is magnified, inverted and formed at I. IM is the real image formed at 6 cm from the lens. The height of the image is 2 cm. Since the scale is 1 cm represents 6 cm, the image is 36 cm from the lens and the height of the image is 12 cm (Fig. 2.27) above.

Example 2.2

A concave lens has a focal length of 2 cm and real object 1.0 cm tall is placed at 3 cm from the centre of the lens. By means of an accurate scale diagram, find the position, size and the nature of the image formed.

Solution

Scale chosen: 1 cm to represent 1 cm

Similar to Example 2.1, draw minimum two incident rays from B and the corresponding refracted rays. Since the refracted rays diverge, a virtual image is formed.

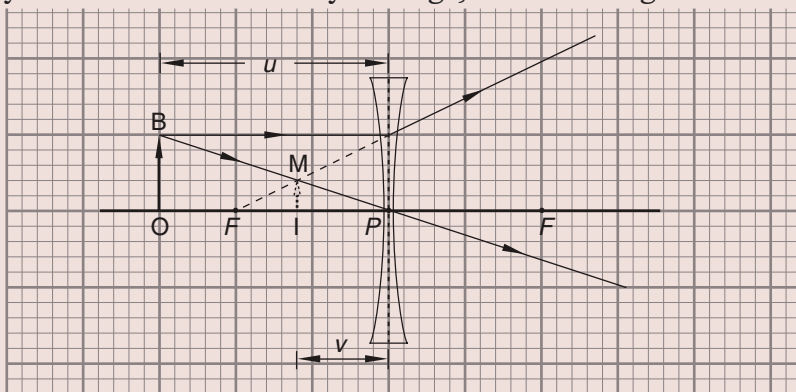

Fig. 2.28

The image is 1.2 cm from the lens and the height of the image is 0.4 cm (Fig. 2.28). It is diminished, upright and virtual.

Exercise 2.2

1. Name two features of the image formed by a convex lens when:
(a) The object is between F and optical centre (b) The object is at F.
(c) The object is at infinity.
2. Sketch a ray diagram to show image formation for an object placed between $2F$ and F of a converging lens. State four characteristics of the image.
3. (a) If a convex lens picks up rays from a very distant object, where is the image formed?
(b) If the object is moved towards the lens, what happens to the position and size of the image?
4. An object 2 cm high is placed 2 cm away from a convex lens of focal length 6 cm. By using an accurate drawing on graph paper, find the position, height and type of the image.

2.6 The lens formula

Activity 2.9

Lens formula

(Work in groups)

1. Using reference materials or internet research about the relationship between focal length, f , object distance, u , and image distance, v .
2. What is the lens formula? Derive it.

3. How is it important to learning of convex and concave mirrors or curved reflecting surfaces?

The lens formula is a formula relating the focal length, image and object distance. Consider a convex lens of focal length, f , which forms a real image IM of an object OB as shown in Fig. 2.29.

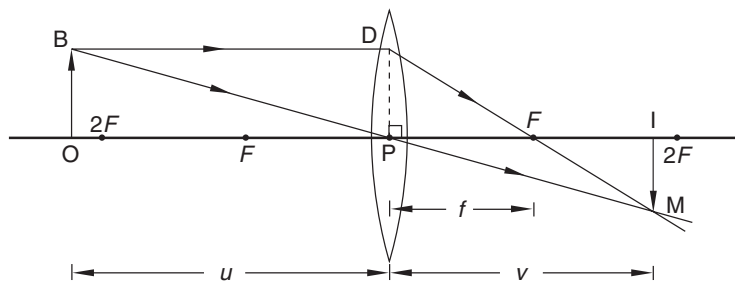

Fig. 2.29: Lens formula

Triangles OBP and IMP are similar (3 angles are equal)

$$\therefore \frac{OB}{IM} = \frac{OP}{IP} \dots\dots\dots (1)$$

Draw a line DP perpendicular to the principal axis where $DP = BO$. Triangles PDF and IMF are similar (3 angles are equal)

$$\therefore \frac{DP}{IM} = \frac{PF}{IF} \dots\dots\dots (2)$$

Since $DP = OB$, from equations (1) and (2),

$$\frac{OP}{IP} = \frac{PF}{IF}$$

$$\frac{u}{v} = \frac{f}{v-f}$$

Cross multiplying, $uv - uf = vf$

Dividing both sides by uvf

$$\frac{uv}{uvf} - \frac{uf}{uvf} = \frac{vf}{uvf} \Rightarrow \frac{1}{f} - \frac{1}{v} = \frac{1}{u}$$

Hence $\frac{1}{f} = \frac{1}{u} + \frac{1}{v}$. This is the **Lens formula**, where

u stands for the distance of the object from the optical centre.

v stands for the distance of the image from the optical centre.

f stands for the focal length of the lens.

2.7 Sign Convention (Real is positive)

We can adopt a method or a convention to describe the upward motion and downward motion. For example let the distances up be negative and down positive or vice versa.

$$\therefore 3 \text{ m up} = -3 \text{ m}$$

$$3 \text{ m down} = +3 \text{ m}$$

There are several sign conventions used when the distances of the object and the image are measured from the lens. In this book, we shall adopt the *real is positive* in which:

1. All the distances are measured from the optical centre.
2. The distances of the real objects and the real images measured from the optical centre are taken as *positive*, while those of virtual objects and virtual images are taken as *negative*. From this convention, *the focal length of a convex lens is positive and that of a concave lens is negative*. See Fig. 2.30 (a) and (b).

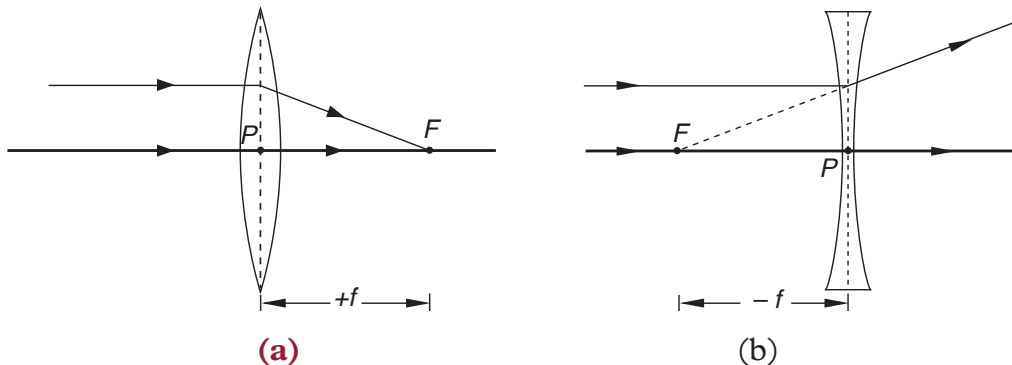

Fig. 2.30: Real and virtual focal lengths of lenses

Example 2.3

An object is placed 24 cm from the centre of a convex lens of focal length 20 cm. Calculate the distance of the image from the lens.

Solution

$$\begin{aligned} \text{From } \frac{1}{f} &= \frac{1}{v} + \frac{1}{u} \Rightarrow \frac{1}{v} = \frac{1}{f} - \frac{1}{u} \\ &= \frac{1}{20} - \frac{1}{24} \\ &= \frac{6-5}{120} = \frac{1}{120} \end{aligned}$$

The image distance (v) = 120 cm

Example 2.4

An object is placed 2 cm from the centre of a concave lens of focal length 20 cm. Calculate the distance of the image from the lens.

Solution

$$\begin{aligned}\text{From lens formula; } \frac{1}{f} &= \frac{1}{v} + \frac{1}{u} \Rightarrow \frac{1}{v} = \frac{1}{f} - \frac{1}{u} \\ &= \frac{1}{20} - \frac{1}{2} \\ &= \frac{1 - 10}{20} = \frac{-9}{20}\end{aligned}$$

$$v = \frac{-20}{9} = -2.2 \text{ cm, } v = 2.2 \text{ cm}$$

v is negative because the image is virtual.

2.8 Magnification formula of the lens

The term magnification refers to how many times an image is bigger than the object. Linear magnification (m) is defined as the ratio of the height of the image to the height of the object.

Activity 2.10

To derive magnification formula

(Work in groups)

Material

- Graph papers

Steps

1. Draw three vertical lines on a graph paper.

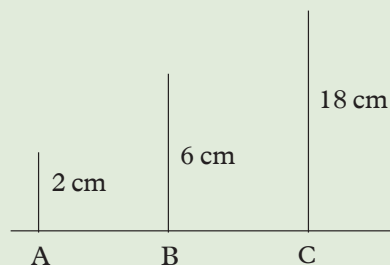

Fig. 2.31

2. How many times is line B bigger than A.
3. How many times is line B bigger than C.
4. What are the units of these comparisons?

Earlier in this unit we have done activities where we saw that the size of images formed by lenses are either bigger or smaller than the object. The increase or decrease in size of an object is called magnification. That is

$$\begin{aligned} \text{Linear magnification } (m) &= \frac{\text{height of the image}}{\text{height of the object}} = \frac{h_1}{h_0} \\ &= \frac{\text{image distance } (v)}{\text{object distance } (u)} = \frac{v}{u} \end{aligned}$$



Note: Since magnification is a ratio, it does not have units

Sometimes it becomes difficult to measure the height of the image or the object accurately. In such cases, magnification can be calculated in terms of distances u and v . For example, consider a convex lens where a magnified image is formed (Fig. 2.32).

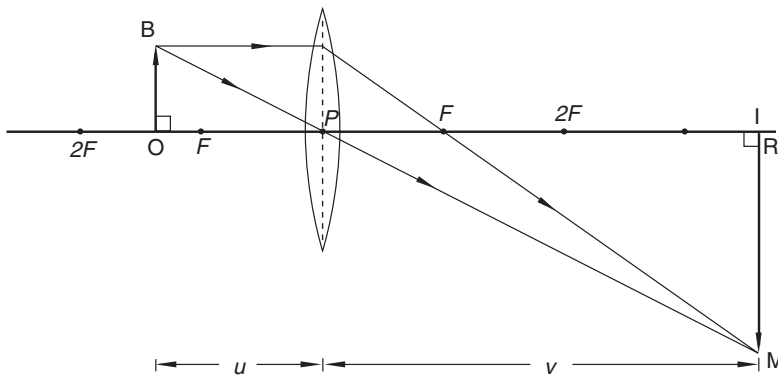

Fig. 2.32: Magnification

Since triangles OBP and IMP are similar (3 angles are equal), the ratios of corresponding sides are equal i.e,

$$\begin{aligned} \frac{IM}{IP} &= \frac{OB}{OP} \\ \therefore \frac{IM}{OB} &= \frac{IP}{OP} = \frac{v}{u} \end{aligned}$$

Hence magnification, $m = \frac{IM}{OB} = \frac{v}{u}$

$$\text{Magnification } (m) = \frac{\text{image distance } (v)}{\text{object distance } (u)} \text{ or } m = \frac{v}{u}$$

Therefore $m = \frac{h_i}{h_o} = \frac{v}{u}$, therefore, the ratio of image to object sizes $\left(\frac{h_i}{h_o}\right)$ is also equal to the ratio of image to object distances $\left(\frac{v}{u}\right)$ measured from the optical centre.

Example 2.5

An object of height 2 cm is placed 20 cm in front of a convex lens. A real image is formed 80 cm from the lens. Calculate the height of the image.

Solution

$$m = \frac{h_i}{h_o} = \frac{v}{u} \Rightarrow \frac{h_i}{2} = \frac{80}{20}$$

$$\therefore h_i = \frac{80 \times 2}{20} = 8 \text{ cm}$$

Example 2.6

An object placed 30 cm from a convex lens produces an image of magnification 1. What is the focal length of the lens?

Solution

Magnification, $m = \frac{OB}{IM} = \frac{OP}{IP} = 1$. (Fig. 2.33)

Since $m = 1$; then $v = u$

This occurs when object is at $2f$.

Hence $2f = 30$

$$\therefore f = 15 \text{ cm}$$

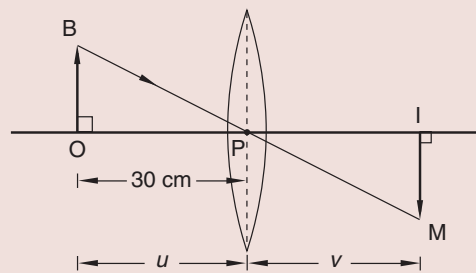

Fig. 2.33: Image formed by convex lens

Example 2.7

An object of height 1.2 cm is placed 2 cm from a convex lens and real image is formed at 36 cm from the lens. Calculate

- (a) the focal length of the lens
- (b) magnification produced by the lens
- (c) the size of the image.

Solution

(a) From lens formula, $\frac{1}{u} + \frac{1}{v} = \frac{1}{f}$

$$\frac{1}{2} + \frac{1}{36} = \frac{1}{f}$$

$$\frac{18 + 1}{36} = \frac{19}{36} = \frac{1}{f}$$

$$\frac{36}{19} = \frac{1}{f} \Rightarrow f = 1.89 \text{ cm}$$

Focal length of the lens = 9 cm

(b) $m = \frac{v}{u} = \frac{36}{2} = 3$

(c) $m = \frac{h_i}{h_o}$

$$\therefore h_i = 3 \times 1.2 = 3.6$$

Size of the image = 3.6 cm

Example 2.8

An object of height 2 cm is placed 8 cm from a convex lens and a virtual image is formed on the same side as the object at 24 cm from the lens. Calculate (a) the focal length of the lens (b) the height of the image formed.

Solution

(a) From lens formula, $\frac{1}{u} + \frac{1}{v} = \frac{1}{f}$

$$\frac{1}{8} + \frac{1}{-24} = \frac{1}{f} \quad (v = -24 \text{ cm because the image is virtual})$$

$$\frac{3 - 1}{24} = \frac{1}{f} \Rightarrow \frac{1}{12} = \frac{1}{f}$$

\therefore focal length, $f = 12 \text{ cm}$

(b) Magnification $m = \frac{v}{u} = \frac{h_1}{h_0} \Rightarrow \frac{-24}{8} = \frac{h_1}{2}$ (negative sign indicate image is virtual)

$$\therefore h_i = \frac{24 \times 2}{8} = 6 \text{ cm}$$

Example 2.9

A convex lens produces a real image of an object and the image is 3 times the size of the object. The distance between the object and the image is 80 cm. Calculate the focal length of the lens.

Solution

Magnification $m = \frac{v}{u} = 3$

$$\therefore v = 3u \dots\dots\dots (1)$$

$$u + v = 80 \dots\dots\dots (2)$$

Solving equations (1) and (2)

$$u + 3u = 80 \Rightarrow 4u = 80$$

$$\therefore u = 20 \text{ cm}$$

Hence $v = 3u = 60 \text{ cm}$

From lens formula $\frac{1}{f} = \frac{1}{u} + \frac{1}{v} = \frac{1}{20} + \frac{1}{60}$
 $= \frac{3+1}{60} = \frac{4}{60} = \frac{1}{15}$

$$\therefore \text{focal length, } f = 15 \text{ cm}$$

2.9 Power of a lens

Activity 2.11

To explain what is the power of a lens

(Work in groups)

Material

- A lens

Steps

1. Discuss with your classmates what the power of the lens is.
2. Is it possible to increase the power of a lens? Discuss.
3. Share your findings with other classmates.

The ability to collect rays of light and focus them at a point in the case of a converging, or to diverge them so that they appear to come from a point in the case of diverging lens is called the **power of a lens**. It is calculated from its focal length using the formula

$$\text{Power} = \frac{1}{f}$$

The unit for power is the **diopetre** represented by the symbol **D**. The **f** must be in S.I units of length.

Example 2.10

A lens has a focal length of 25 cm. Find the power of the lens.

Solution

$f = 25 \text{ cm} = 0.25 \text{ m}$. The focal length of convex lens = +ve (It forms real image)

$$\therefore \text{Power} = \frac{1}{+0.25} = +4 \text{ m}^{-1}$$

NB: For a concave lens $f = -\text{ve}$ (because a concave lens forms a virtual image)

$$\therefore \text{Power} = \frac{1}{-0.25} = -4 \text{ m}^{-1}$$

Exercise 2.3

1. Define the terms: principal axis, optical centre and focal length of a convex lens.
2. With the help of a diagram, show the action of a convex lens as a converging lens.
3. The focal length of a diverging lens is 15 cm. With the help of a diagram explain the meaning of this statement.
4. Fig. 2.34 below shows a convex lens of focal length 15 cm and two rays of light parallel to the principal axis.

Copy and complete the diagram to show the path of these rays as they pass through the lens. Label the position of the principal focus as *F*.

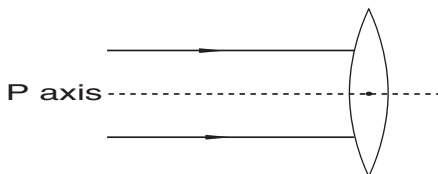

Fig. 2.34

5. Draw ray diagrams showing how a convex lens could be used to produce
 - (a) a real and diminished image
 - (b) a virtual and magnified image of a real object.

6. Fig. 2.35 is drawn to scale. One incident ray from the object is parallel to the principal axis and other ray passes through the principal focus of a convex lens. Copy and complete the diagram to show the path of the ray through the lens. Hence determine (i) position of the image (ii) the magnification produced by the lens.

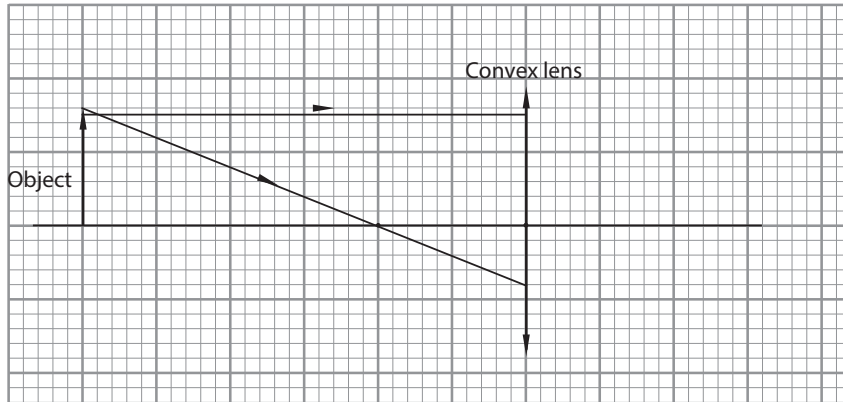

Fig. 2.35

7. Copy the table below and put a tick (✓) in three of the boxes to describe the image formed by a diverging lens.

Table 2.1

Magnified	
Diminished	
Upright	
Inverted	
Virtual	
Real	

8. Draw a diagram to show how a convex lens produce a virtual image.
9. Fig. 2.36 shows two rays of light approaching a thin diverging lens. Copy and complete the diagram and show the path of the rays as they pass through and emerge out of the lens. Label the position of the principal focus F .

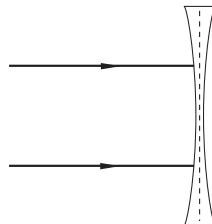

Fig. 2.36

10. Fig. 2.37 is drawn to scale. An object OB placed in front of a convex lens of focal length 5.0 cm. Copy and complete the diagram and (a) show the position of the image (b) find the size of the image

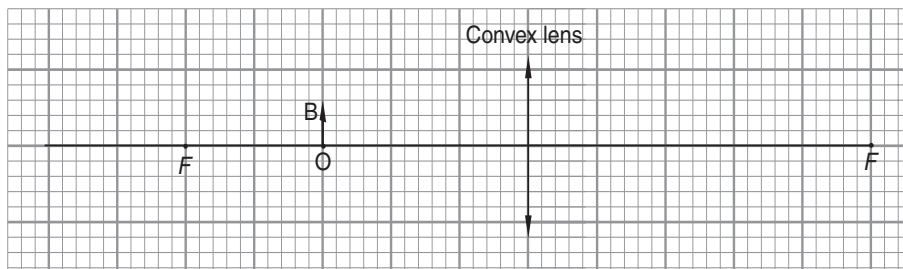

Fig. 2.37

11. A convex lens is used to form an upright, magnified image of an object placed 6 cm from the lens. Calculate the focal length of the lens, if the magnification produced is 4.
12. An object 3 cm high is placed 20 cm from a lens of focal length -25 cm. Find the position, size and the nature of the image formed.
13. At what distance must an object be placed from a convex lens of focal length 20 cm so as to get real image 4 times the size of the object?
14. An object 3 cm high is placed 30 cm from a convex lens of focal length 20 cm
(a) Find the position, size and the nature of the image formed (b) If the same object is now moved by 20 cm towards the lens, calculate the magnification produced by the lens.
15. A convex lens forms a focused image on a screen when the distance between an illuminated object and the screen is 1 m. The image is 0.25 times the size of the object. Calculate (a) the object distance from the lens (b) the focal length of the lens used.
16. An object 3 cm high is placed 150 cm from a screen. Calculate the focal length of the lens that has to be placed between the object and the screen, so as to produce a real image 6 cm high on the screen.
17. An object 6 cm high is placed 30 cm from a diverging lens of focal length 15 cm. With the help of a scale diagram determine
(a) the position of the image.
(b) the magnification produced by the lens.
18. A real object placed 8 cm in front of a converging lens produces an image at a distance of 2 cm from the lens and on the same side as the object. Calculate the focal length of the lens.
19. A diverging lens of focal length 24 cm forms an image at 18 cm from the lens. Calculate the distance of the object from the lens.
20. In an experiment to determine the focal length of a converging lens, a student obtains the results shown in Table 2.3.

Table 2.2

u (cm)	21.0	24.0	33.0	36.0	45.0	60.0
v (cm)	50.0	40.0	22.5	25.0	22.0	20.0

- (i) Plot a graph of u (x-axis) against v (y-axis)
- (ii) Using the graph, determine the focal length of the lens.

2.10 Applications of thin lenses

1. The human eye

The human eye consists of a nearly spherical ball of about 2.5 cm diameter except for a slight bulge at the front. Fig. 2.38 shows the cross-section of the human eye with the optic nerve leading to the brain.

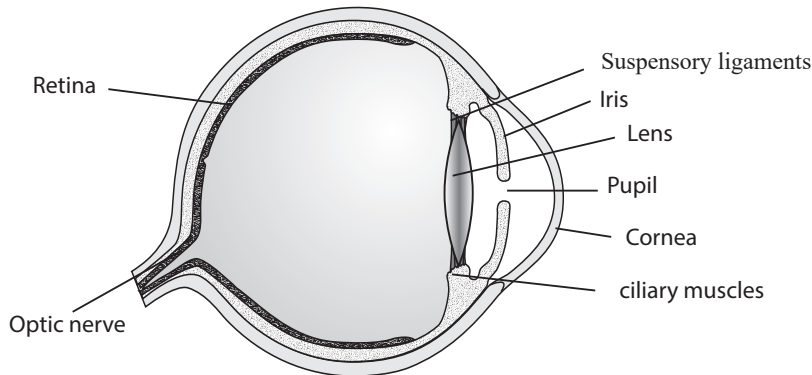

Fig. 2.38: A cross-section of a human eye.

The front portion of the eye is known as the *cornea* and is slightly bulged outwards and is transparent in nature. Behind the cornea, there is a diaphragm called the *iris*, with a hole in the middle known as the *pupil*.

Behind the iris is a *crystalline lens*. This is a biconvex converging lens made of a large number of jelly-like layers which are flexible and transparent in nature. The lens is suspended inside the eye by the help of *suspensory ligaments* which fasten it to the *ciliary muscles*. These muscles control the shape of the lens.

The lens forms a real, diminished and inverted image on the *retina*. Light falling on the retina produces a sensation in the cells which then send the electrical signals to the brain by the nerve known as the *optic nerve*.

The amount of light reaching the retina is regulated by the size of the pupil. When a bright object is viewed, the iris reduces the size of the pupil so as to admit less light, whereas in dark light the iris contracts so as to admit as much light as possible.

An image formed by the eye lens leaves an impression on the retina for about 0.1 second. This persistence of the vision enables us to “see” cinema or television pictures which appear to change smoothly from one image to the next without

any interruption. In a cinema theatre or television screen about 20 pictures are projected per second. During the time interval between the pictures, the eye “remembers” the previous picture.

Image formation in the eye

When one looks at far objects, such as a tree, the eye lens becomes thinner and the focal length of the lens increases. The ciliary muscle is relaxed and the lens has the longest focal length. It is able to focus rays from distant objects onto the retina (Fig. 2.39 (a)).

To view the objects close to the eye, the lens becomes thicker and the focal length of the lens decreases. The contraction of the ciliary muscle reduces tension in the lens and the lens becomes more curved with short focal length and is more powerful. The lens now focuses images of near objects onto the retina (Fig. 2.39 (b)). For both far view and close view the image formed is real, diminished and inverted. This process by which the lens of the eye changes its focal length and produces focused images of both distant and near objects on the retina is called *accommodation*.

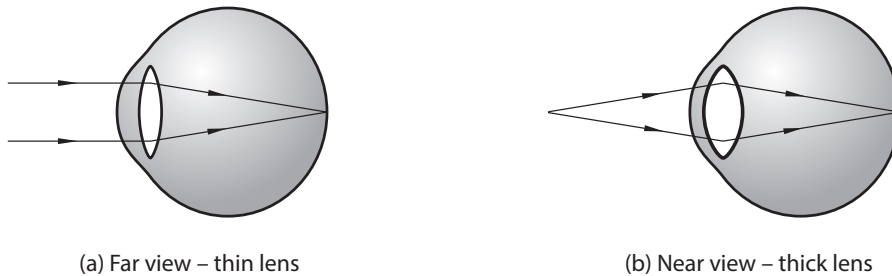

Fig. 2.39: Accommodation of the eye

In the eye, the distance between the eye lens and the retina remains the same, whereas the lens automatically changes its focal length according to the distance of the object. This effect is brought about by changing the shape of the ciliary muscle attached to the lens.

Defects of vision

A normal human eye can accommodate the range of distances from far off objects to objects close to the eye. There is, however, a limit to the power of accommodation of the eye. As a person grows older, the power of accommodation gradually decreases. Also, despite the ability of the eye to adjust its focal length by changing the lens shape, some eyes cannot produce clear images over the normal range of vision. This type of defect may arise due to the eyeball being slightly too long or too short compared to the normal spherical ball or due to the curvature of the cornea being defective.

The most common defects of vision are *short-sightedness (myopia)* and *long-sightedness (hypermetropia)* (see Fig. 2.40, (a) (b)).

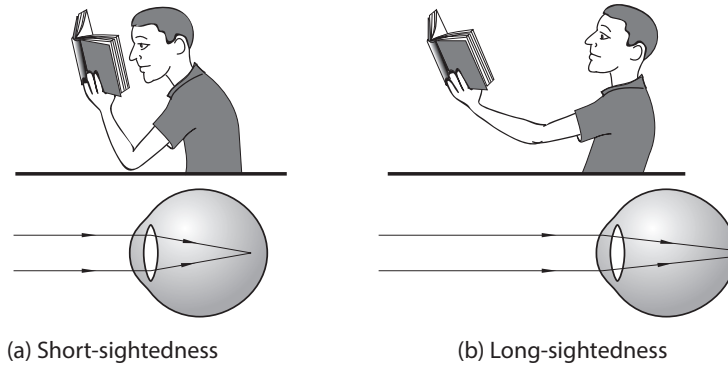

Fig. 2.40: Short-sightedness and long-sightedness

(a) Short-sightedness or Myopia

A person suffering from short-sightedness can only see nearby objects. The image of a distant object is formed in front of the retina as shown in Fig. 2.33 (a). This defect arises due to the eyeball being too long or more refraction takes place at the cornea and hence the focal length of the eye lens becomes short.

In order to correct this defect, a concave lens of appropriate focal length should be used. This lens diverges the rays from a distant objects so that they appear to come from a virtual image formed at a point closer to the lens. The eye can focus on this virtual image, as shown in Fig. 2.41 (b).

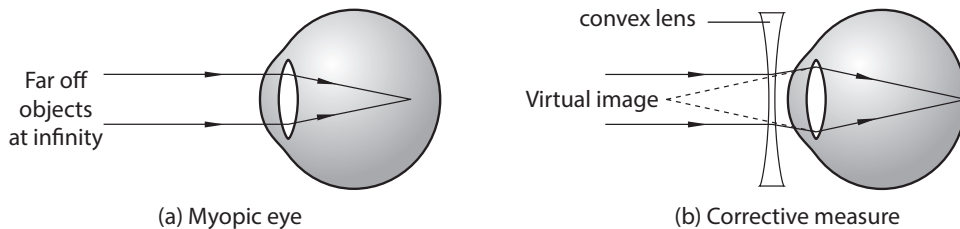

Fig. 2.41: Short-sightedness and corrective measure.

(b) Long-sightedness or Hypermetropia

A person suffering from long-sightedness can see distant objects clearly, but cannot see distinctly objects lying closer than a certain distance. The image of a nearby object is formed behind the retina as shown in Fig. 2.42 (a). The defect arises due to the eyeball being too short or due to the curvature of the cornea being defective and the focal length of the eye lens becoming longer.

In order to correct this defect, a convex lens of appropriate focal length should be used. This lens converges the ray from a near object so that they appear to come from a virtual image formed at a point far off from the lens. The eye focuses on this virtual image as shown in Fig. 2.42 (b).

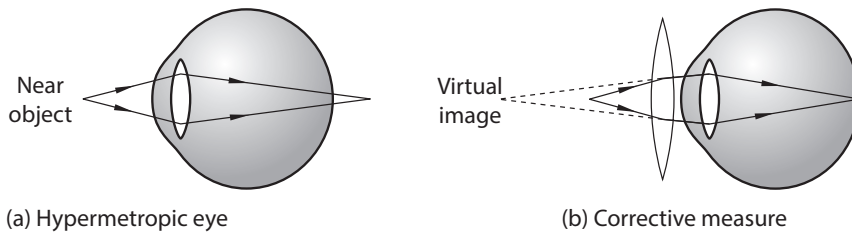

Fig. 2.42: Long-sightedness and the corrective measure.

2. The lens camera

A camera is a device used to take photographs. A human eye, though in principle, is similar to a camera, is far superior than the finest camera ever made by man. Fig. 2.43 (a) shows some parts of a lens camera. Fig. 2.43 (b) shows a commercial camera.

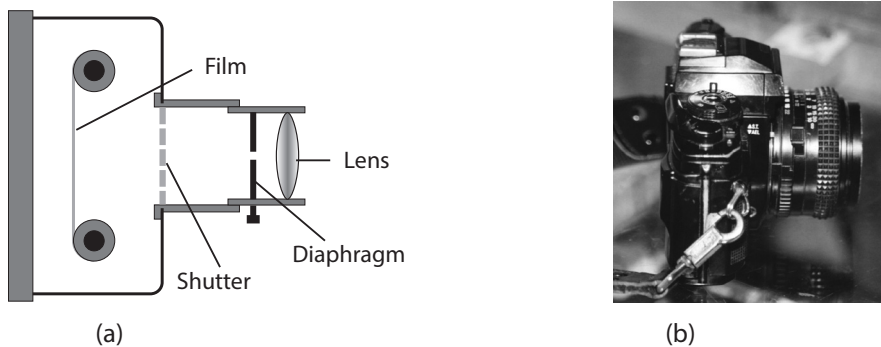

Fig. 2.43: A lens camera

A camera consists of a converging lens and a light sensitive film or plate enclosed in a light-tight box, blackened from inside. The lens focuses light from an object to form a real, diminished and inverted image on the film. Focusing of objects is done, by adjusting the distance between the lens and the films. The amount of light entering the camera through the lens is regulated with the help of a diaphragm, with an adjustable opening in the middle.

Light is admitted by the shutter, which opens for different required intervals of time and then closes automatically. During this interval of time, the film is exposed to light from the object. The film contains light sensitive chemicals that change on exposure to light. The film is developed to get what is called a *negative*. From the negative a photograph (positive) may be printed.

Comparison of a lens camera with the human eye

Similarities

1. Both use converging lenses
2. Both produce real, inverted, diminished images.

3. Both can control the amount of light entering the device.
4. Both are black inside.

Differences

Camera	Eye
1. Focal length of the lens is constant.	1. Focal length of the lens changes with the thickness of the lens.
2. Distance between the lens and the film can be altered.	2. Distance between the lens and the retina is a constant.
3. Focuses objects between a few centimetres from the lens to infinity.	3. Focuses objects between 25cm from the lens to infinity.
4. Form permanent images at the film.	4. Form temporary images at the retina.

Example 2.11

A lens camera is used to take photograph of a distant building. A well focused image is formed on the film. The lens of the camera is 6 cm from the film.

- (a) What is the focal length of the lens? Give reasons for your answer.
- (b) If the camera is then used to take a photograph of a person 2.0 m away from the lens, without moving the camera, in which direction should the lens be moved in order to produce the best possible image?

Solution

- (a) Focal length of the lens = 6 cm. Since the object is a distant building, the light rays incident on the lens are almost parallel and are brought to focus at the principal focus of the lens.
- (b) As the object distance is only 2.0 m i.e. object distance, u , has decreased as compared to the distance in part (a). Hence the image distance, v , must be increased. To achieve this, the lens has to be moved forward towards the person.

3. Simple microscope

A *magnifying glass* also known as a *simple microscope* is an instrument used to view the details of very small objects. It consists of a single converging lens of short focal length. When an object is placed within the focal length of such a lens, a magnified image which is virtual and upright is formed on the same side of the object. This image can be viewed by placing the eye close to the lens. The distance of the object from the lens is adjusted till an enlarged image is formed at a distance D , which is about 25 cm from the unaided eye. The distance D is referred to as

the *least distance of distinct vision*. Fig. 2.44 below illustrates the operations of a simple microscope.

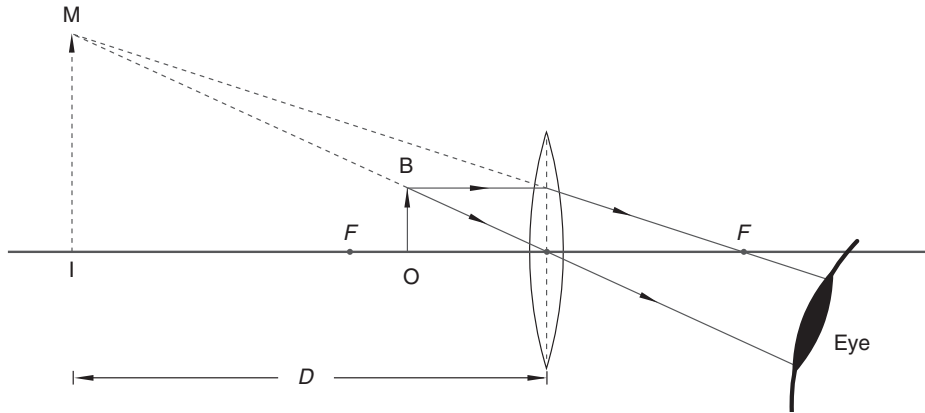

Fig. 2.44: A simple microscope.

The action of a simple microscope

The object OB , when viewed by an unaided eye, cannot be brought closer to the eye, than the distance D (Fig. 2.45 (a)). Otherwise the image as seen by the eye will not be clearly visible. When the same object is viewed through the magnifying glass, it moves nearer to the eye so that a magnified image is formed at the same distance D as before (Fig. 2.45 (b)). Therefore a simple microscope enables us to bring an object very close to the eye making it appear magnified and yet clearly visible.

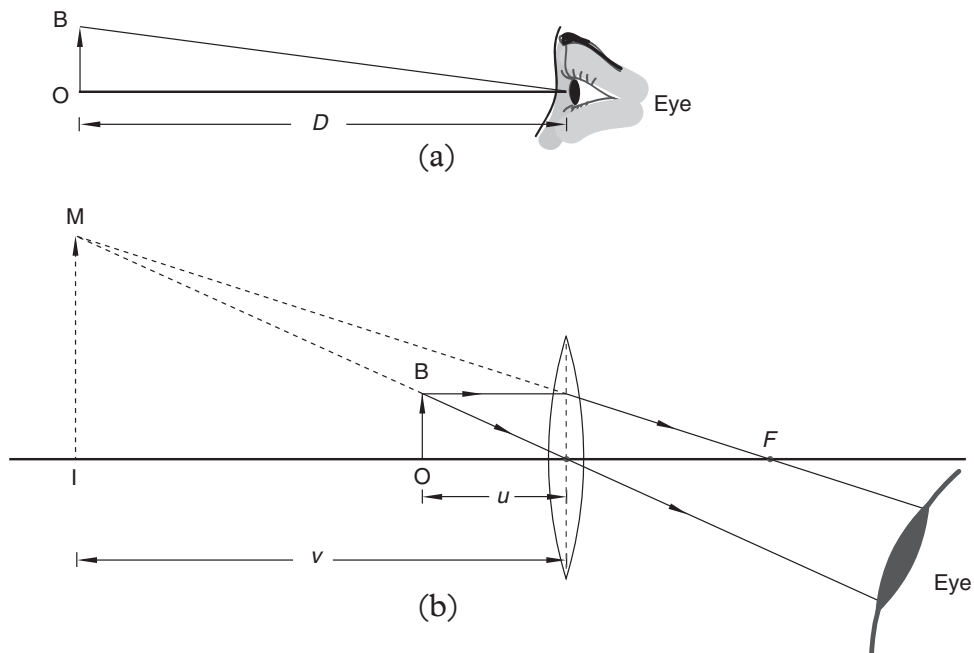

Fig. 2.45: Working of a simple microscope

Magnifying power of a simple microscope

$$\text{Linear magnification } m = \frac{\text{IM}}{\text{OB}} = \frac{v}{u}$$

Linear magnification of a lens is also called *magnifying power* of the instrument.

In a simple microscope, the image distance v is negative, as the image is virtual.

$$\text{Hence, from the lens formula } \frac{1}{u} - \frac{1}{v} = \frac{1}{f}$$

Multiplying throughout by v and simplifying,

$$m - 1 = \frac{v}{f}$$

$$m = 1 + \frac{v}{f}$$

From the above expression the shorter the focal length of the lens, the greater is the magnifying power of the instrument. Hence a simple microscope uses a converging lens of short focal length.

Example 2.12

Calculate the magnification produced by a lens of focal length 5.0 cm used in a simple microscope, the least distance of distinct vision being 25 cm.

Solution

In this example, the image distance $v = D = 25$ cm.

$$\begin{aligned} \text{Magnification, } m &= 1 + \frac{v}{f} \\ &= 1 + \left(\frac{25}{5}\right) \\ &= 1 + 5 = 6 \end{aligned}$$

Hence the magnification produced by the lens = 6.

4. Compound microscope

In a simple microscope, the magnifying power cannot be increased beyond a certain limit, by decreasing the focal length of the lens. This is due to the mechanical difficulties of using a lens of very short focal length. A compound microscope uses two separate converging lenses, placed coaxially within two sliding tubes, to obtain a higher magnifying power. The lens O, nearer the object is called the *objective lens* and the lens E closer to the eye, is called the *eyepiece lens*. Though both these lenses are of short focal lengths, the eyepiece has a comparatively larger focal length than the objective lens. The final image formed is magnified, virtual and inverted as shown in Fig. 2.46.

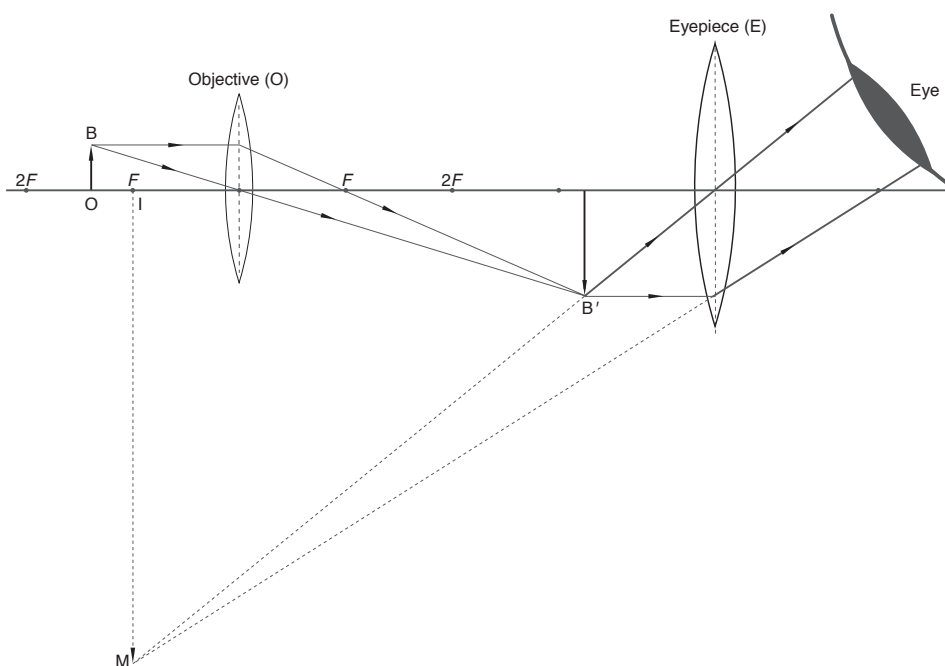

Fig. 2.46: A compound microscope

Action of a compound microscope

The object OB is placed between F and $2F$ of the objective lens. A real, inverted, magnified image $O'B'$ is formed beyond $2F$ of the objective lens. The position of the eyepiece lens is adjusted so that this image $O'B'$ falls within its focal length. The eyepiece then acts as a magnifying glass and produces a final magnified, virtual and inverted image IM at a distance of distinct vision D from the eye, placed very close to the eyepiece. If m_1 is the magnification produced by the objective lens and m_2 is the magnification produced by the eyepiece lens, then the magnification produced by the system of lenses m is given by,

$$m = m_1 \times m_2$$

If the first image $O'B'$ formed by the objective lens is exactly at the principal focus F_e of the eyepiece lens, then the final image IM will be formed at infinity. The image will be inverted and well enlarged. At this position, the compound microscope is said to be in *normal adjustment*.

A good compound microscope produces a very high magnification. High magnification microscopes are usually used in research work in science (see Fig. 2.47).

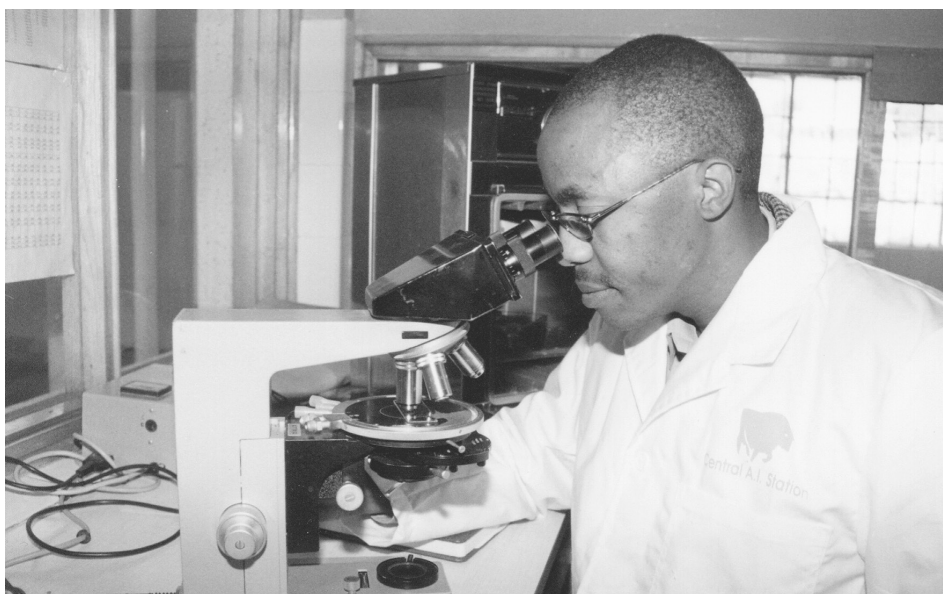

Fig. 2.47: High magnification microscope for research work

Example 2.13

In a compound microscope, the focal length of the objective lens is 2.0 cm and that of the eyepiece is 2.2 cm and they are placed at a distance of 8.0 cm. A real object of size 1.0 mm is placed 3.0 cm from the objective lens.

- Use the lens formula in turn for each lens to find the position of the final image formed.
- Calculate (i) the magnification produced by the arrangement of these lenses and (ii) the size of the final image viewed by the eye?

Solution

(a) For the objective lens $\frac{1}{u} + \frac{1}{v} = \frac{1}{f}$

$$\frac{1}{3} - \frac{1}{v} = \frac{1}{2}$$

Solving this equation gives $v = 6$ cm

As shown in Fig. 2.48, the real image I_1M_1 is formed at 6 cm from the objective lens. I_1M_1 acts as an object for the eyepiece ($u = 2$ cm).

For the eyepiece lens $\frac{1}{u} + \frac{1}{v} = \frac{1}{f}$

$$\frac{1}{2} - \frac{1}{v} = \frac{1}{2.2}$$

Solving this equation gives $v = -22$ cm

The negative sign shows that the image formed by the eyepiece is virtual and is formed on the same side as the object I_1M_1 . The final image I_2M_2 is at a distance of 22 cm from the eyepiece (see Fig. 2.48).

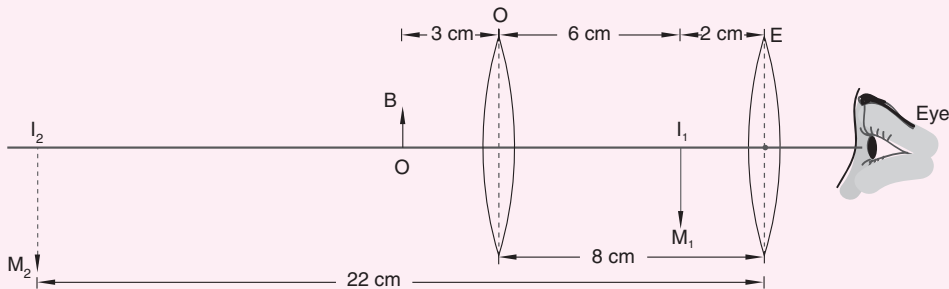

Fig. 2.48: Arrangement of lenses in a compound microscope

(b) (i) The magnification produced by the system of lenses $m = m_1 \times m_2$

where $m_1 = \frac{v}{u}$ for the objective lens and $m_2 = \frac{v}{u}$ for the eyepiece.

$$m = \frac{6}{3} \times \frac{22}{2} = 2 \times 11$$

$$= 22$$

(ii) The size of the final image = size of the object $\times m$

$$= 1 \times 22$$

$$= 22 \text{ mm}$$

Topic summary

- **A lens** is a transparent medium bound between two surfaces of definite geometrical shape.
- Thin lenses may either be converging or diverging.
- **A convex lens** is thicker at its centre than its edges and converges the light incident on it.
- **A concave lens** is thicker at its edges than at the centre and diverges the light incident on it.
- The following are some of the important terms used in spherical lenses: principal axis, optical centre, principal focus, focal length.
- **The focal length** of a convex lens is positive, while that of a concave lens is negative.
- The characteristics of the image formed by a converging lens depends on the position of the object (see Table 2.3).

Table 2.3

Position of object	Position of image	Nature of image formed	Size of image formed compared to object
At infinity (far away)	F	real and inverted	diminished
Beyond $2F$	Between F and $2F$	real and inverted	diminished
At $2F$	At $2F$	real and inverted	Same size
Between $2F$ and F	Beyond $2F$	real and inverted	Magnified
At F	At infinity (far away)	real and inverted	Magnified
Between F and P	Same side as object	Virtual and upright	Magnified

- A diverging lens always forms a virtual, upright, diminished image between F and P (except when the object is at infinity).
- **Magnification (m)** is defined as the ratio of the height of the image to the height of the object

$$\text{magnification} = \frac{\text{height of image}}{\text{height of object}} = \frac{\text{image distance}}{\text{object distance}}$$

- Lens formula is given by $\frac{1}{u} + \frac{1}{v} = \frac{1}{f}$ where u is the object distance, v the image distance and f the focal length of the lens.
- Short-sightedness and long-sightedness are two most common defects of a human eye
- A lens camera, simple microscope, compound microscope are some examples of optical instruments.

Topic Test 2

1. Describe an experiment to illustrate that white light is composite in nature.
2. Fig. 2.49, drawn to scale, shows two rays starting from the top of an object OB incident on a converging lens of focal length 2 cm.

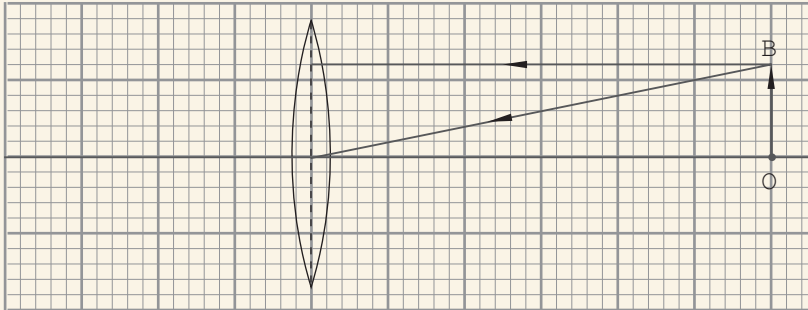

Fig. 2.49: Equilateral glass prism

- (a) Copy and complete the diagram to determine where the image is formed.
 - (b) Add one more incident ray from B through the principal focus and draw the corresponding refracted ray through the lens.
 - (c) Calculate the magnification produced by the lens.
3. Fig. 2.50 shows an object placed at right angles to the principal axis of a thin converging lens.

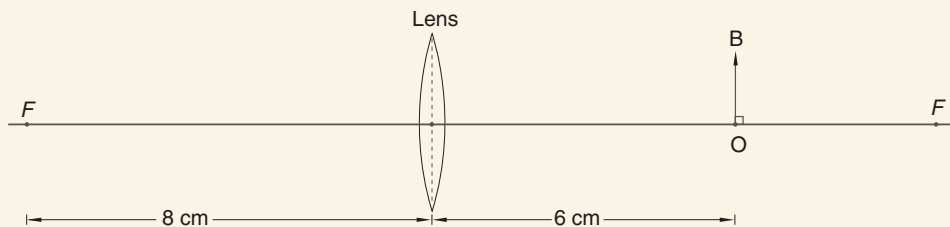

Fig. 2.50: Equilateral glass prism

- (a) Calculate the position of the image formed.
 - (b) Give an application of this arrangement of a lens.
 - (c) Describe the nature of the image formed.
4. Describe with the aid of a ray diagram, how an image is formed in a (i) simple microscope (ii) lens camera.
 5. A converging lens is used to form an upright image, magnified 5 times of an object placed 6 cm from the lens. Determine the focal length of the lens

6. Fig. 2.51 shows two converging lenses L_1 and L_2 placed 8 cm from each other. The focal length of the lens L_1 is 2 cm and that of L_2 is 2.8 cm. An object 1.0 cm high is placed 3 cm from lens L_1 .

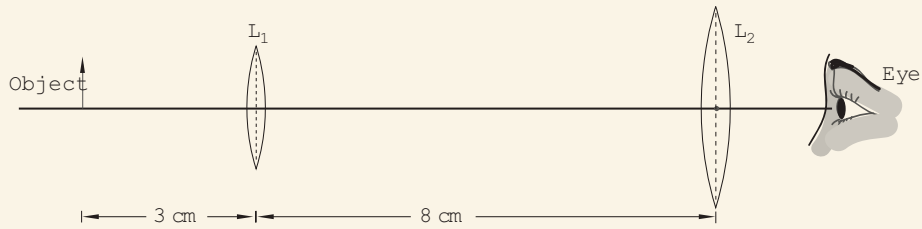

Fig. 2.51: Equilateral glass prism

- (a) Construct a ray diagram to scale, on a graph paper to show the position of the final image as seen by the eye of a person.
- (b) Determine the magnification obtained by this arrangement.

Topics in the unit

Topic 3: Moment of a Force

Topic 4: Centre of Gravity and Equilibrium

Learning outcomes**Knowledge and Understanding**

- The effects of forces and centre of gravity.

Skills

- Design tests to locate the centre of gravity of regular objects by method of balancing and locate the centre of gravity of irregular shaped objects by means of a plumb-line.
- Observe carefully.
- Predict what might happen.
- Use appropriate measures.
- Draw a simple diagram to show moment of a force Interpret results accurately.
- Calculate problems related to moments of forces.
- Report findings appropriately.

Attitudes

- Appreciate the applications of moment of forces.

Key inquiry questions

- Why the pivot is important in taking moment of force?
- What do you understand by couple forces?
- Why cars are designed to have a wide base?
- Why an object cannot be in equilibrium if it is in motion?
- Why an overloaded vehicle is prone to overturn?

Unit Outline >>>

- Moment of force
- Principle of moments
- Couple
- Determination of centre of mass of a regular object
- Applications of moment of a force

Introduction

One of the effects of a force we learnt about in Secondary 1 is that it produces a turning effect on body. But how can we quantify the turning effect? What are some of the applications of this effect in our daily lives? In this topic, we will seek answers to these questions.

3.1 Moment of a force

A number of simple machines like levers, pliers, spanners and so on do work when a force produces a turning effect on some of their parts. It is important to know where the force should be applied for the machine to be more efficient in doing work.

The following activity will help us to investigate the turning effect of a force.

Activity 3.1**To investigate the turning effect of a force**

(Work in groups)

Materials

- A ruler.

Steps

1. Balance a ruler on a finger. At what point did the ruler balance? Why do you think it balances at that point?
2. Press the ruler at one end. Observe what happens to the ruler.
3. Repeat the experiment by pressing the ruler on the other end. Why do you think the ruler behaves in such a manner?

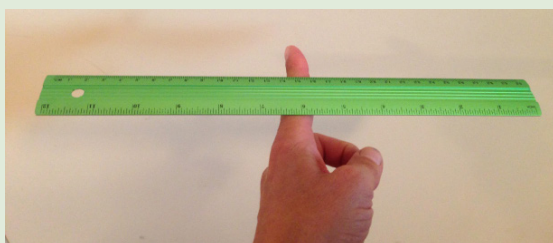

Fig. 3.1: Balancing a ruler on a finger

In both cases, the ruler turns about the finger. When the force F_1 is applied at one end, the ruler turns in *anticlockwise direction* about the finger. When the force F_2 is applied at the other end, the ruler turns in the *clockwise direction*. Both F_1 and F_2 produce a turning effect on the ruler about the finger.

The turning effect of a force about a point is called the *moment of the force about that point*. This moment depends on the force applied and its distance from the point.

The moment of a force about a point *is the product of the force and the perpendicular distance from the point to the line of action of the force*.

The moment of a force about a point is either clockwise or anticlockwise about the point.

In Fig. 3.1, the anticlockwise moment about the finger is $F_1 \times d_1$. The clockwise moment about the finger is $F_2 \times d_2$.

$$\begin{aligned} \text{Moment of a force about a point} &= \text{Force} \times \begin{array}{l} \text{Perpendicular distance from the point} \\ \text{to the line of action of the force} \end{array} \\ &= F \times d \end{aligned}$$

SI unit of moment of a force

Moment of a force = Force (N) \times Perpendicular distance (d).

Therefore, the *SI unit* of moment is *newton metre (Nm)*.

Moment of a force is a *vector quantity* since it has both magnitude and direction.

Example 3.1

A student applies a force of 10 N to the handle of a door, which is 0.8 m from the hinges of the door (Fig. 3.2). Calculate the moment of the force.

Solution

Moment of a force about a point

$$= \text{Force} \times \text{perpendicular distance} \\ \text{from the point to the force.}$$

$$= (10 \times 0.8) \text{ Nm}$$

$$= 8 \text{ Nm in the clockwise direction.}$$

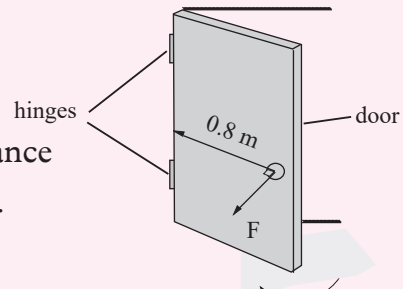

Fig. 3.2: Moment in opening the door

Example 3.2

Calculate the moment of the force about the fulcrum when a pet dog of mass 10 kg is at a distance of 1.2 m from the fulcrum of the seesaw as shown in Fig. 3.3.

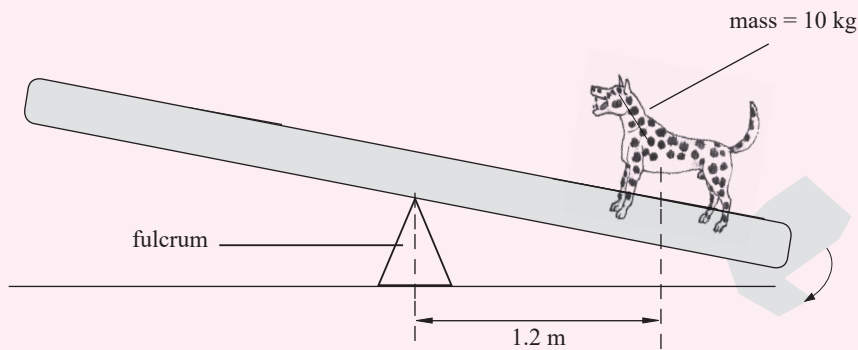

Fig. 3.3: Moment of force

Solution

$$F = \text{Weight of dog} = mg = 10 \text{ kg} \times 10 \text{ N/kg} \\ = 100 \text{ N}$$

Moment of the force about the fulcrum

$$= \text{Force} \times \text{perpendicular distance from the fulcrum} \\ = 100 \text{ N} \times 1.2 \text{ m} \\ = 120 \text{ Nm in the clockwise direction.}$$

Exercise 3.1

1. Define 'moment of a force' and state its SI unit.
2. A force of 20 N is applied to open the gate of a fence as shown in Fig. 3.4. Calculate the moment of the force about the hinges if the force is applied at the edge of the gate.

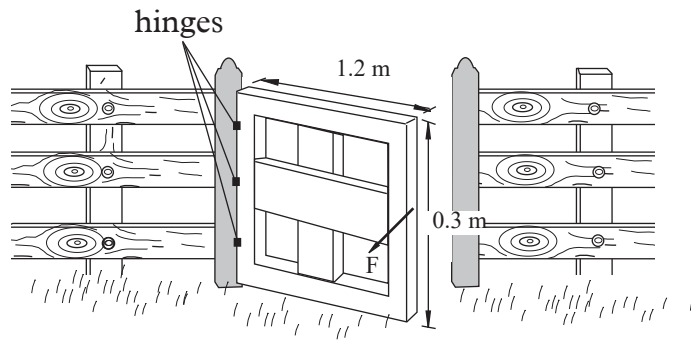

Fig. 3.4: Moment in opening the gate

3. Give the scientific reasons for the following:

- (a) The handle of a door is fixed far from the hinges.
- (b) A pair of garden shears has small blades and long handles.
- (c) A lighter boy is able to produce same moment as that of a heavier girl on the seesaw as shown in Fig. 3.5 below.

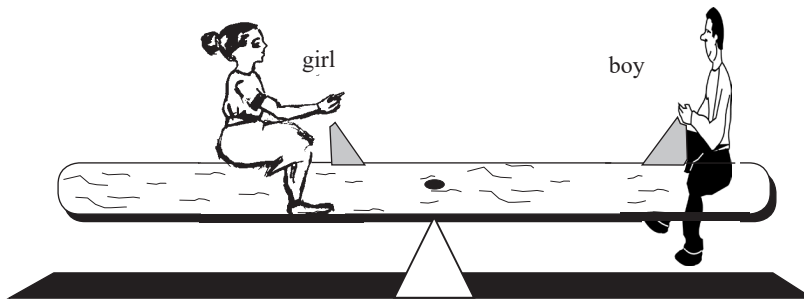

Fig. 3.5: Moment on a seesaw

4. A person applies a force of 500 N and produces a moment of force of 300 Nm about the wheels of a wheel cart (Fig. 3.6). Calculate the perpendicular distance, d , from the line of action of the force to the wheels.

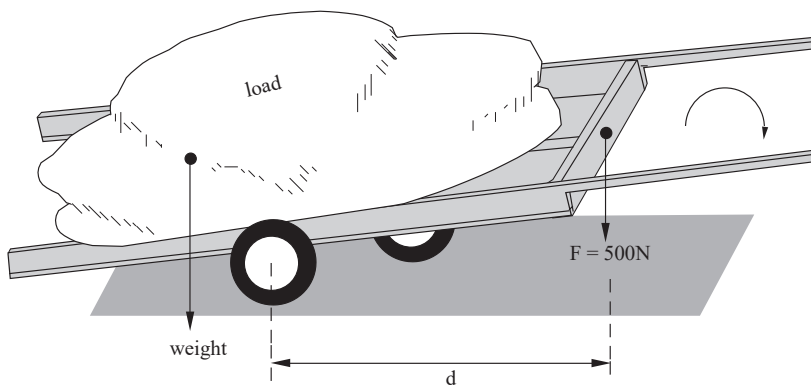

Fig. 3.6: Moments in a wheelcart

3.2 The principle of moments

The principle of moment gives the relationship between two moments that are at the same turning point (fulcrum).

Activity 3.2

To investigate the principle of moments

(Work in groups)

Materials

- A metre rule
- string
- Three 100 g mass
- support e.g. clamp

Steps

1. Suspend a uniform metre rule from a firm support e.g. clamp, at the 50 cm mark, i.e. at its mid point G as shown in Fig. 3.7 (a) using a string.
2. Suspend a 100 g mass at a point A as shown in Fig. 3.7 (b). Why do you think the ruler balances as shown?

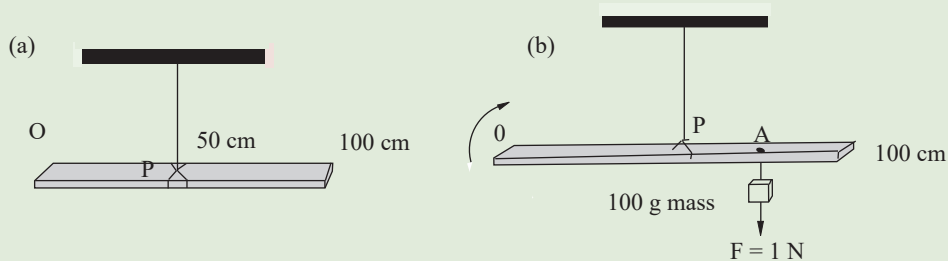

Fig. 3.7: Principle of moments.

3. Now suspend a 200 g mass at a point B near the 0 cm mark (Fig. 3.8 (a)). What has happened? The system turns in the anticlockwise direction. Now adjust the position of B till the system balances horizontally as shown in Fig. 3.8 (b). Explain the observations.

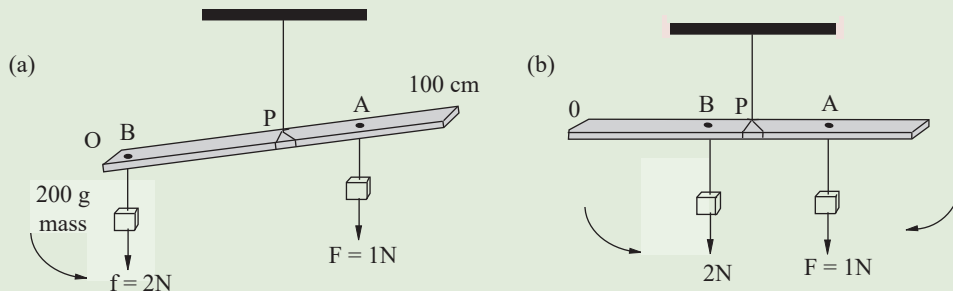

Fig. 3.8: Principle of moments.

The metre rule turns in the clockwise direction. There is a moment of force in the clockwise direction due to the force acting vertically downwards at point A.

Moment of the force in the clockwise direction = Force \times perpendicular distance = $1.0 \times PA$

Moment due to the 2 N force about P is $2.0 \times PB$ in the anticlockwise direction. Measure the distance PA and PB. Compare the values of $1.0 \times PA$ and $2.0 \times PB$. What can you say about these values?

We note that the two moments are equal in magnitude and opposite in direction. The clockwise moment of the 1 N force about point P is equal to the anticlockwise moment of the 2 N force about point P.

Activity 3.3

To design and investigate the principle of moments with more than two forces

(Work in groups)

Materials

- Four mass
- A metre rule
- string
- Firm support e.g. clamp

Instructions

1. In this activity, you will design and carry out an investigation to investigate the principle of moments with more than two forces.
2. By modifying the set-up, we used in Activity 3.2, with the materials provided, i.e using its masses, conduct an investigation. Sketch the new set-up.
3. Write a brief procedure and carefully execute the procedure to determine principle of moments with four masses.
4. By applying the relevant formula and relationships. Calculate the moments about point P.
5. Compare your values with other groups.
6. What are some possible sources of errors? How can they be minimised in your investigation? Write a report and present it in a class discussion.

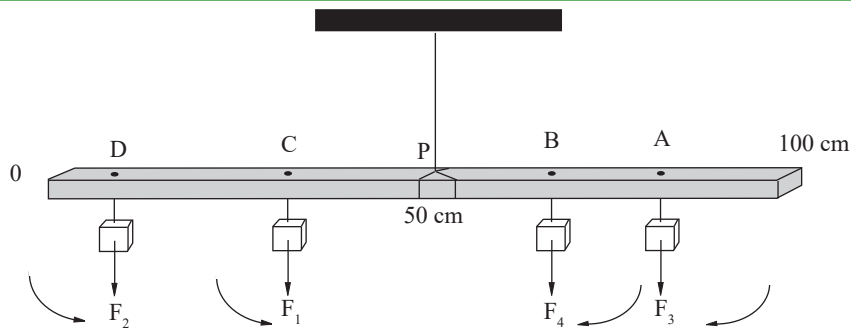

Fig. 3.9: Balanced metre rule under action of forces.

The sum of the clockwise moments = $F_3 \times PA + F_4 \times PB$.

The sum of the anticlockwise moments = $F_1 \times PC + F_2 \times PD$.

What can you say about $F_1 \times PC + F_2 \times PD$ and $F_3 \times PA + F_4 \times PB$?

From Activity 3.2 and 3.3 we can conclude that the sum of the clockwise moments about a point is equal to the sum of the anticlockwise moments about the same point, when the metre rule is balanced.

In Activity 3.3, we saw how a body can be balanced by a number of forces. *When a body is balanced under the action of a number of forces, it is said to be in **equilibrium**.* The results of Activities 3.2 and 3.3 are summarised in what is known as *the principle of moments*.

It states that, *when a body is in equilibrium under the action of forces, the sum of clockwise moments about any point is equal to the sum of anticlockwise moments about the same point.*

Activity 3.4

To verify the principle of moments

(Work in groups)

Materials

- A metre rule
- Seven, 50 g masses

Steps

1. Consider a uniform metre rule suspended at its mid point P, which is the 50 cm mark. Suspend 3 masses; 200 g, 100 g and 50 g and adjust their positions A, B and C till the system is in equilibrium as shown in Fig. 3.10.
2. Calculate the distances PA, PB and PC in metres and enter the values in a table.

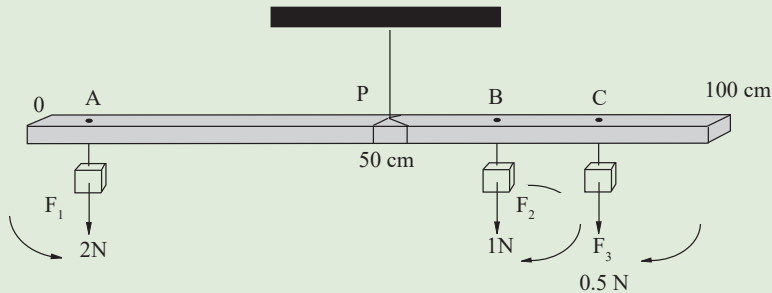

Fig. 3.9: Verifying the principle of moments.

3. Repeat the experiment by changing the positions of A or B or C or all the three so that the metre rule balances horizontally in each case. Record the results in Table 3.1.

Table 3.1

	PA (m)	PB (m)	PC (m)	$F_1 \times PA$ (Nm)	$F_2 \times PB + F_3 \times PC$ (Nm)
1					
2					
3					
4					

4. Complete the table and explain the results.

It is seen that the last two columns are equal for each set of results proving that the sum of the clockwise moments is equal to the sum of the anticlockwise moments about point P.

$$F_2 \times PB + F_3 \times PC = F_1 \times PA$$

Example 3.3

A uniform metre rule is pivoted at its centre P, and 3 masses are placed at A, B and C as shown in Fig. 3.10. Find the value for the weight W of the mass M placed at C so that the metre rule is balanced horizontally.

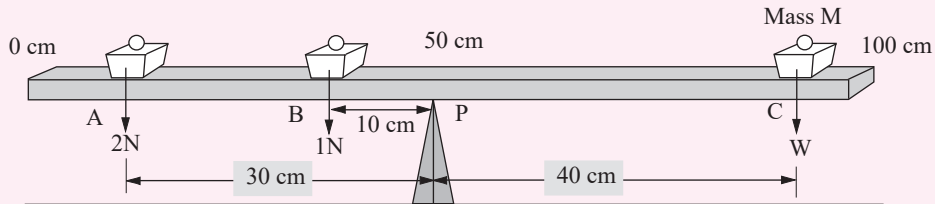

Fig. 3.10: Principle of moment

Solution

Taking moments about P, when the metre rule is in equilibrium.

Sum of the clockwise moments = Sum of the anticlockwise moments

$$W \times 0.4 = (2.0 \times 0.3) + (1.0 \times 0.1)$$

$$W = \frac{(2.0 \times 0.3) + (1.0 \times 0.1)}{0.4}$$

$$= 1.75 \text{ N}$$

Example 3.4

John, Joyce and Janet sat on a seesaw as shown in Fig. 3.11 below. Where is John, whose mass is 30 kg seated so that the seesaw is balanced horizontally if the masses of Joyce and Janet are 50 kg and 20 kg respectively?

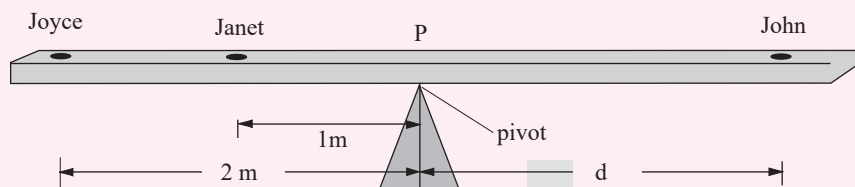

Fig. 3.11: See saw at balance

Solution

John's weight = 600 N, Joyce's weight = 500 N, Janet's weight = 200 N

Taking moments about the pivot,

Sum of clockwise moments = Sum of the anticlockwise moments

about the pivot about the pivot

$$600 \times d = 500 \times 2 + 200 \times 1$$

$$600 d = 1\,000 + 200$$

$$d = \frac{1\,200}{600} = 2 \text{ m}$$

John should sit at a distance of 2 m from the pivot.

Example 3.5

The uniform plank of wood in Fig. 3.12 is balanced at its center by the forces shown. Determine the value of W in kg.

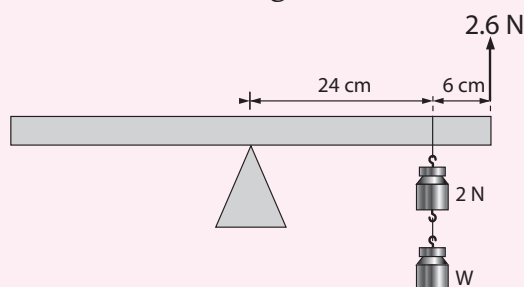

Fig. 3.12

Solution

Note that the 2.3 N produces an anticlockwise moment.

Sum of clockwise moments = Sum of anticlockwise moments

$$0.24 \times (2 + W) = 2.6 \times 0.30$$

$$0.48 + 0.24W = 0.78$$

$$\Rightarrow W = \frac{0.78 - 0.48}{0.24} = 1.25 \text{ N}$$

$$= 0.125 \text{ kg}$$

Activity 3.5

To determine the mass of an object using the principle of moments

(Work in groups)

Materials

- A metre rule
- A known mass
- An unknown mass
- Support

Steps

1. Suspend a uniform metre rule at its mid point P. Suspend the object of mass m , using a string, from a point A. Suspend a known mass M on the other side of the metre rule and adjust the position of the mass M till the metre rule is horizontal as shown in Fig. 3.13.

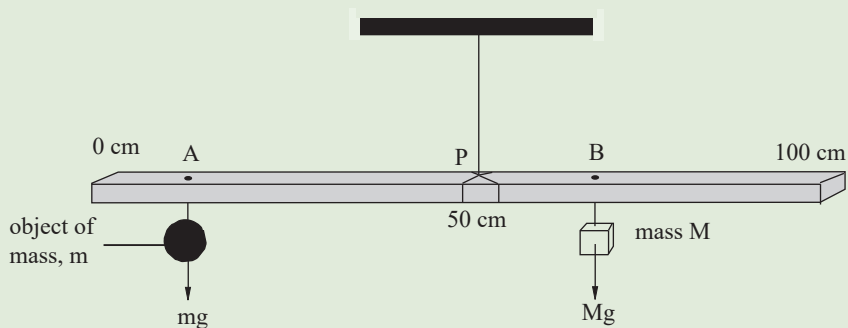

Fig. 3.13: Finding unknown mass m .

- Record the distances PA and PB. Repeat the experiment by changing the position of the object or the mass M. Enter the readings of M, PA and PB in a tabular form as shown in Table 3.2.

Table 3.2

	Mass M(g)	PA(cm)	PB(cm)	$m = \frac{M \cdot PB}{PA}$ (g)
1				
2				
3				
Mean				

- Calculate the mean value for the mass of the object from the last column.

Taking moments about P,

$$(mg) \times PA = (Mg) \times PB,$$

$$m \times PA = M \times PB, \quad (\text{g cancels out})$$

$$\therefore m = \frac{M \times PB}{PA}$$

Exercise 3.2

- State the principle of moments.
- A boy of mass 20 kg sits on one side of a log of wood and 10 m away from the pivot. A girl of mass 30 kg sits on the opposite side of the log. How far is the girl from the pivot.
- State two conditions for a system to be in a state of equilibrium.
- Weights of 25 N, 28 N and 8 N were suspended on a uniform plank of wood pivoted at its center on a knife-edge. Fig. 3.14 shows the plank immediately after it was placed on a knife-edge.

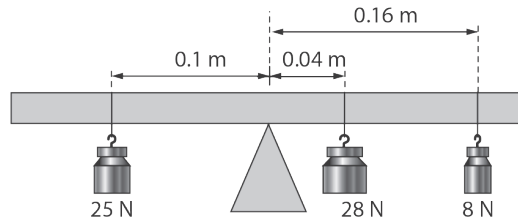

Fig. 3.14

(a) Work out:

- (i) Sum of Clockwise moments
- (ii) Sum of Anticlockwise moments

(b) Is the bar in a state of equilibrium? Give a reason for your answer.

5. A uniform metre rule is pivoted at the center. It is balanced by weights of 8 N, F and 24 N suspended at 34 cm, 43 cm and 30 cm marks respectively (Fig. 3.15). Calculate the value of F .

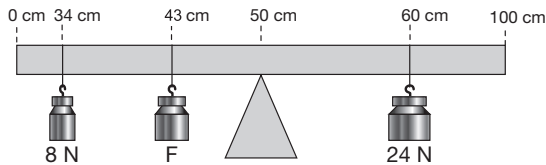

Fig. 3.15

6. Fig. 3.16 below shows a modern bar balanced by forces of 210 N, 100 N and 25 N. Calculate the distance d .

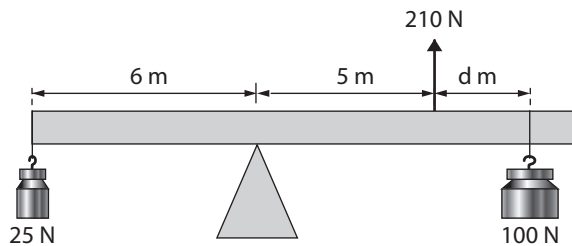

Fig. 3.16

3.3 Couple

Couple refers to two parallel forces that are equal in magnitude, opposite in sense and do not share a line of action. Its effects is that it creates rotation without translation as shown in Fig. 3.17.

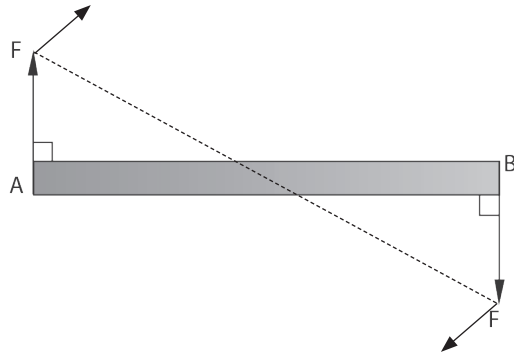

Fig. 3.17: A couple

A couple produces a turning effect on a body.

Moment of a couple

Fig. 3.18 shows a couple acting on bar AB.

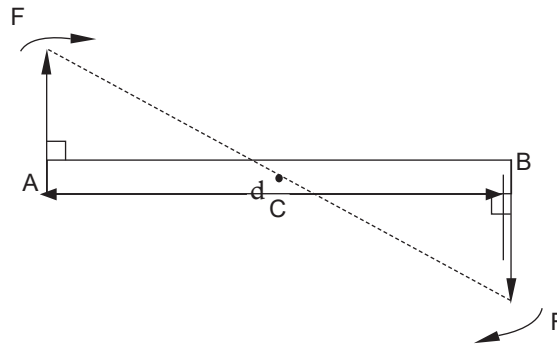

Fig. 3.18: Moment of a couple

Since the pivot is at C, the moment of the force F acting at point A = $F \times AC$, in the clockwise direction.

Similarly, the moment of the force, F acting at point B = $F \times BC$, also in the clockwise direction.

$$\begin{aligned} \therefore \text{The moment of the couple} &= (F \times AC) + (F \times BC) \\ &= F (AC + BC), \text{ but } AB = AC + BC \\ &= F \times AB = F \times \text{Arm of the couple.} \end{aligned}$$

The moment of the couple, called the *torque* which is defined as the *total rotating effect* of a couple and is given by the product one of the forces and the perpendicular distance between the forces.

Hence, in Fig. 3.18,

$$\text{Torque} = F \times \text{perpendicular distance AB.}$$

SI unit of torque is the *newton-metre (Nm)*

Example 3.6

In Fig. 3.19, each force is 4 N and the arm of the couple is 20 cm. Calculate the moment of the couple.

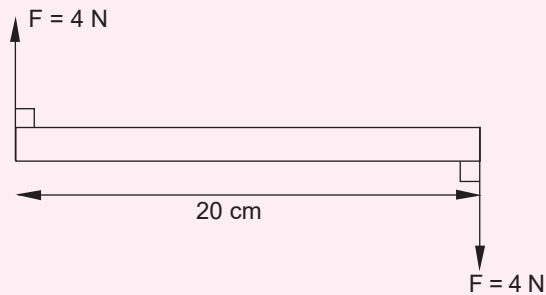

Fig. 3.19: Moment of a couple

Solution

$$\begin{aligned}\text{The moment of the couple} &= F \times \text{perpendicular distance} \\ &= 4 \text{ N} \times 0.20 \text{ m} \\ &= 0.80 \text{ Nm.}\end{aligned}$$

Some common real life examples of a couple are observed when:

- Forces are applied by hands to turn a steering wheel of a motor car (Fig. 3.20 (a)) or the handle bars of a bicycle.
- A water tap is opened or closed (Fig. 3.20 (b)).
- A corkscrew is twisted into a cork in the mouth of a bottle. (Fig. 3.20 (c)).

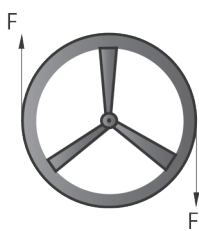

(a) Steering wheel

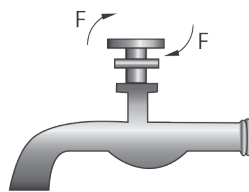

(b) Water tap

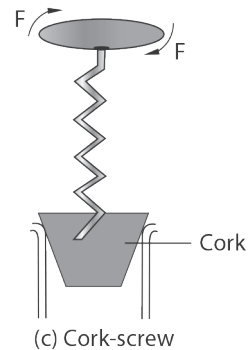

(c) Cork-screw

Fig. 3.20: Moment of couple

Exercise 3.3

1. Fig. 3.21 is a water tap in use. If the diameter of a circular path made by the tap (knob) when is open and closed is 20 cm. Calculate the moment of the couple.

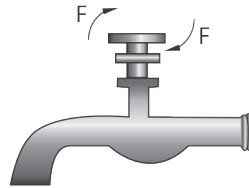

(b) Water tap

Fig. 3.21: Moment of couple of a tap

2. Calculate the torque in Fig. 3.22 below.

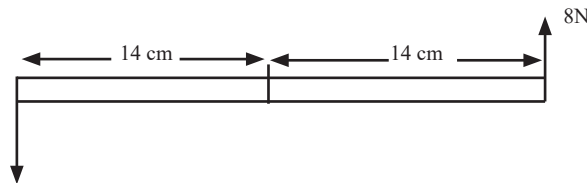

Fig. 3.22: Torque

3. A steering wheel of a truck has a diameter of 30 cm. If the driver is holding the wheel with both hands, while negotiating a corner, calculate the force applied by the right hand if the left hand is pulling the wheel by a force equal to 200 N.

3.4 Centre of mass of a body

In one of his experiments, Sir Isaac Newton showed that bodies experience a force of gravity exerted on them by the earth. This force of gravity is always directed towards the earth's centre and is called the *weight of the body*. How is this weight distributed throughout the body? The answer to this question is found in the following experiment.

3.4.1 Determining centre of mass of regular objects

Activity 3.6

To determine the weight of a beam (uniform metre rule)

(Work in groups)

Materials

- Uniform metre rule
- A mass, m
- A knife edge (fulcrum)

Steps

1. Balance a uniform metre rule of mass m on a fulcrum and adjust its position until the metre rule is horizontal. Note the position P , where it is pivoted (Fig. 3.23(a)).
2. Move the fulcrum to a point A , say to the right of P . Observe what happens. Why do you think the ruler changes its state of equilibrium.
3. Place a mass M between A and 100 cm mark and adjust its position B until the metre rule is horizontal (Fig. 3.23(b)).

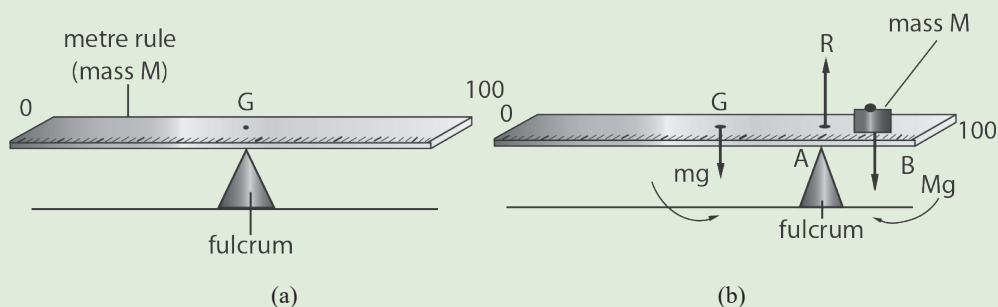

Fig. 3.23: Determination of mass of a uniform metre rule

4. Find the lengths PA and BA . Repeat the experiment by changing the position of A or the mass M .
5. Record the mass of M , length PA and length BA in a table (Table 3.3).

Table 3.3

	Mass M (g)	BA (cm)	PA (cm)	$m = \frac{M \cdot BA}{PA}$ (g)
1				
2				
3				
Mean $m =$				

6. Take moments and determine the value of m (the mass of the metre rule).

Taking moments about A

$$mg \times PA = Mg \times BA$$

$$m = \frac{M \times BA}{PA} \quad (\text{g cancels out})$$

Calculate the mean value for the mass of the metre rule from the last column of Table. 3.4. The weight of the metre rule = mg .

Example 3.7

A uniform metre rule pivoted at the 30 cm mark is kept horizontal by placing a 50 g mass on the 80 cm mark. Calculate the mass of the metre rule (Fig. 3.24).

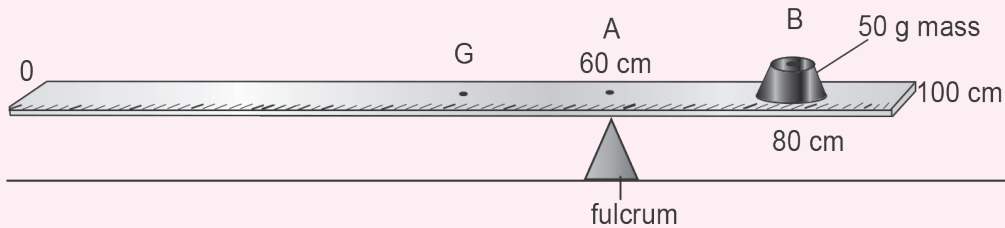

Fig. 3.24: Determining the mass of the metre rule

Solution

Let the mass of the metre rule be m

Force due to $m = m \times g$ where $g = 10 \text{ N/kg}$
 $= 10 m$ newtons

Force due to 50 g mass $= \frac{50}{1000} \times g = 0.05 \times g = 0.50 \text{ N}$.

PA = 10 cm = 0.1 m

AB = 20 cm = 0.2 m

By the principle of moments, taking moments about point A,

$$10 m \times 0.1 = 0.50 \times 0.2$$

$$m = \frac{0.50 \times 0.2}{10 \times 0.1} = \frac{0.10}{1}$$

$$= 0.1 \text{ kg or } 100 \text{ g}$$

Example 3.8

A coffee table of mass 22 kg and length 1.3 m long is to be lifted off the floor on one of its shorter sides to slip a carpet underneath. Calculate the maximum force needed to lift the table.

Solution

Fig. 3.25 shows the forces acting on the table where F is the lifting force and 220 N is the weight of the table acting at the center.

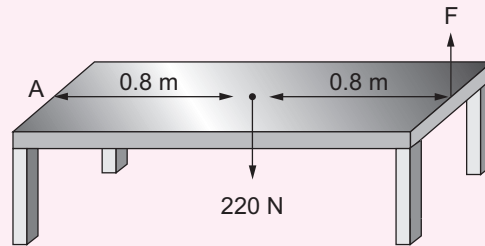

Fig. 3.25

Taking the movement about point A

Sum of Clockwise moments = Sum of Anticlockwise moments

$$220\text{ N} \times 0.8\text{ m} = F \times 1.6\text{ m}$$

$$\Rightarrow F = \frac{220 \times 0.8}{1.6}$$

$$= 110\text{ N}$$

\therefore The minimum force required = 110 N

Exercise 3.4

1. A uniform metre rule of uniform width 2.5 cm and thickness 0.5 cm is suspended at the 78 cm mark and kept balanced by hanging a mass of 150 g at the 100 cm mark (Fig. 3.26). Calculate, (a) the mass of the metre rule, (b) the density of the material of the metre rule, (c) the tension T in the string.

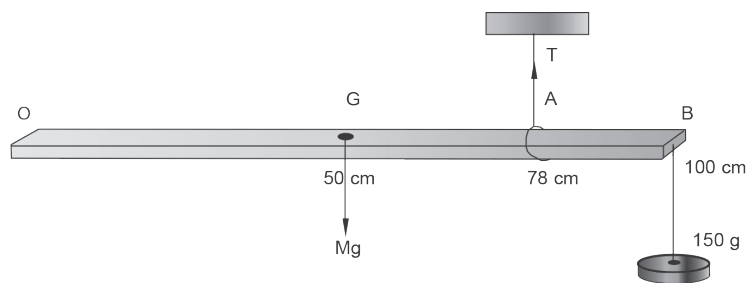

Fig. 3.26: A system at balance

2. A uniform metre rule is balanced at the 20 cm mark by a mass of 240 g placed at one end. (a) Draw a diagram to show the state of balance of the metre rule (b) Determine the weight and mass of the metre rule.
3. A non-uniform plank AB shown in Fig. 3.27 is balanced when a force of 200 N is applied at the end B. The centre of gravity, G , is shown.

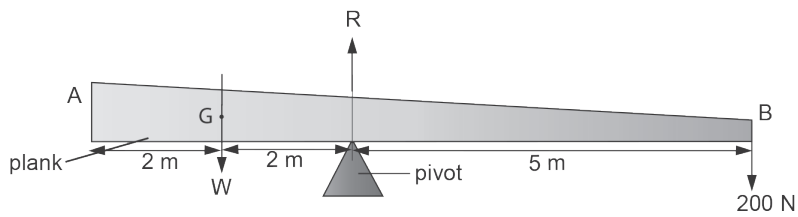

Fig. 3.27: Centre of mass of a plank

Calculate the:

- (a) weight and
- (b) mass of the plank.

3.5 Applications of moment of a force

The following are some of the common examples which illustrate the turning effect of a force i.e moment of a force:

1. Opening or closing a door.
2. Opening a bottle using a bottle opener (Fig. 3.28(a)).
3. A pair of scissors or garden shears in use (Fig. 3.28(b)).
4. Children playing on a “see-saw”.
5. A wheelbarrow being used to carry some load (Fig. 3.28(c)).
6. A wheel cart being used to lift heavy loads.
7. A screwdriver being used to tighten/loosen a screw.
8. A crowbar being used to move large object (Fig. 3.28(d)).

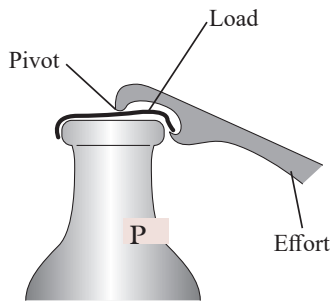

(a) Bottle opener

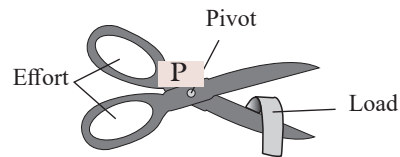

(b) Scissors

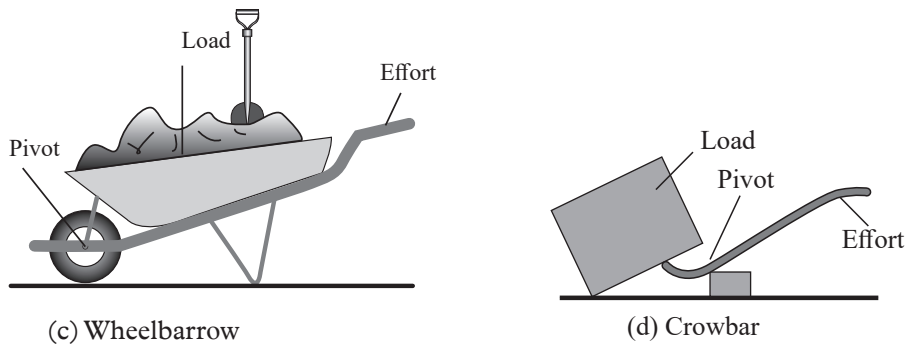

Fig. 3.28: Applications of moment of a force

Note

In all these tools the length of the handle determines the amount of effort to be used. Activity 3.1 will help us to understand this.

Activity 3.7

To investigate the effect of length to the effort needed in using a tool

(Work in groups)

Materials

Exercise books, 3 cm and 15 cm rulers, doors.

Steps

1. Lift a book using a 15 cm ruler. Repeat the same using a 30 cm ruler. Why is it easier to lift a book using a longer ruler than the shorter one?
2. Open the classroom door with your hand near the door hinge. Now, open the same door with your hand far away from the door hinge. Of the activities above, when do you use less effort?

We use less effort when using 30 cm ruler to lift a book.

Several experiments have been done on several tools and machines and proved that:

- (a) The longer the handle, the lesser the effort used when using the machines.
- (b) The shorter the handle, the more the effort used while working with the tools and machines.

Therefore, the manufacturers always design tools and machines such as bottle openers, see-saw, water taps, spanners and wheelbarrows with longer handles so that very little effort be used in working with them.

Exercise 3.5

Sketch and locate the effort, pivot, load in each of the following tools and machines.

- | | | | |
|-------------------|---------------|-------------|---------|
| (a) Bottle opener | (b) Water tap | (c) See-saw | |
| (d) Spanner | (e) pliers | (f) Hammer | |
| (g) Spade | (h) Broom | (i) Spoon | (j) Arm |

Topic summary

- The **moment of a force** about a point is the turning effect of the force about the point.
- The turning effect of the force depends upon the magnitude of the force applied and the perpendicular distance from the pivot.
- The **moment of a force** is the product of the force applied and the perpendicular distance from the pivot to the line of action of the force.
- The moment of a force is a *vector* quantity and its SI unit is Newton metre.
- **Principle of moments** states that the sum of the clockwise moments about a point is equal to the sum of the anticlockwise moments about the same point, when the system is in equilibrium.

Topic Test 3

1. (a) State the principle of moments.
(b) Describe an experiment to prove this principle using two known masses and a uniform metre rule.
2. A uniform metre rule is suspended at the 50 cm mark and a stone at the 0 cm mark. The metre rule is balanced horizontally when a mass of 100 g is suspended at the 30 cm mark. Calculate the weight of the stone.
3. In the diagram shown (Fig. 3.29), calculate the value of the unknown mass M , when the plank is balanced horizontally.

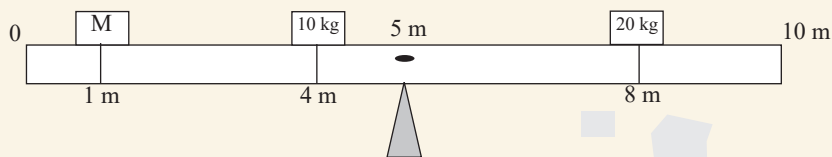

Fig. 3.29: A plank at balance

4. Jane and James are seated at 3 m and 2 m respectively from the centre of a seesaw on one side and Jack at 4 m from the centre on the other side. The seesaw is balanced horizontally. Find the weight of Jack, if the masses of Jane and James are 40 kg and 30 kg respectively.

5. Fig. 3.30 shows a uniform plank pivoted at its centre. Where should a 5 kg mass be attached if the plank is to be perfectly horizontal?

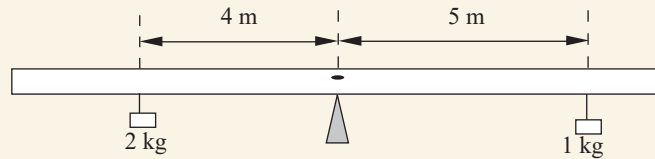

Fig. 3.30: A uniform plank at balcon

6. A uniform metre rule is balanced horizontally at its centre. When a mass of 5 g is suspended at the 4 cm mark, the rule balances horizontally if a mass M is suspended at 30 cm mark. Calculate M .
7. Fig. 3.32 shows a uniform metallic metre rule balanced when pivoted at the 30 cm mark under the conditions shown on the diagram.

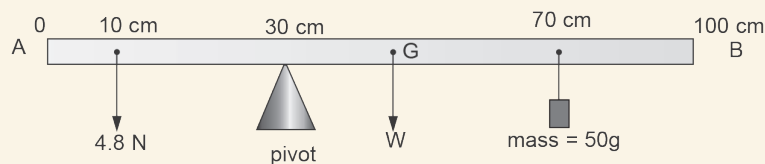

Fig. 3.31: Moments in a uniform rule

- (a) Redraw the diagram showing all the forces acting on the metre.
 (b) Calculate the weight W of the metre rule.
8. Name four importance of moments in our daily life.
9. Fig. 3.32 represents a type of safety valve that can be fitted to the boiler of a model steam engine.

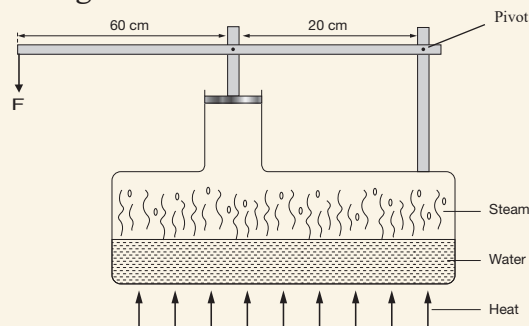

Fig. 3.32

- (a) Briefly explain how the system works..
 (b) What minimum pressure should the steam have in order to escape through the plate which has a cross sectional area 10.3 cm^2 ? (Take atmospheric pressure = 10^5 Pa)

Unit outline ▶▶▶

- Definition of centre of gravity and centre of mass.
- Determination of centre of gravity of regular and irregular objects.
- Effects of the position of centre of gravity on stability of objects.

Introduction

In our day to day experiences, we may have come across statements such as “that object is not stable on the table” or “that overloaded *bus* is not stable on the road”. Have you ever asked yourself what factors control the stability of an object? In this topic, we will study the factors that affect stability of objects and centre of gravity.

Activity 4.1**To locate the centre of gravity of a book**

(Work individually or in groups)

Materials: Exercise book

Steps

1. Take your exercise book and try to balance it horizontally on your finger as shown in Fig 4.1 below.



Fig. 4.1: Balancing a book

- (a) What do you observe?
 - (b) Why do you think the book balances at only one point?
 - (c) What do you think is special about the point where the book balances?
2. Discuss with your group members your observations and thoughts in 1(a), (b) and (c).

By going through the following discussions, you will be able to answer questions 1(a) to (c) in Activity 4.1.

4.1 Centre of gravity and centre of mass of a body

In one of his experiments, Sir Isaac Newton showed that bodies experience a force of gravity exerted on them by the earth. This force of gravity is always directed towards the earth's centre and is called the *weight of the body*. How is this weight distributed throughout the body? The answer to this question is found in the following activity.

4.1.1 To investigate where the weight of a body acts

Activity 4.2

To find the centre of gravity of a regular body

(Work in pairs or in groups)

Materials: A table, thin rectangular card

Steps

1. Place a thin rectangular cardboard near the edge of the bench top.
2. Pull the card slowly away from the bench until it is just about to topple over then released as shown in Fig. 4.2 (a).
3. Using a ruler, mark and draw the line AB along which the card balances.
4. Repeat the activity with the other side of the card, mark and draw the line CD along which the card balances. The lines AB and CD intersect at a point M (Fig. 4.2(b)).

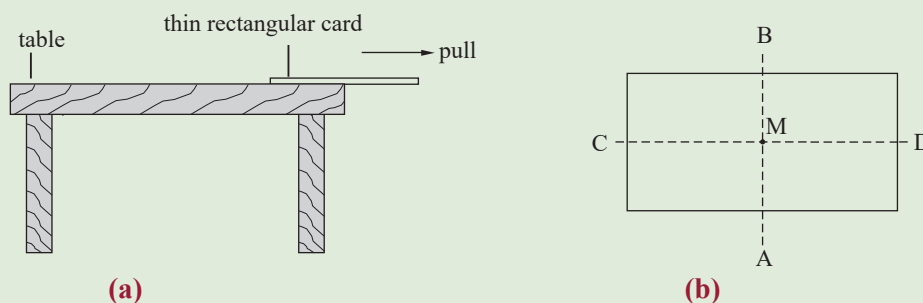

Fig. 4.2: Location of a point where the weight of the body acts

4. Now, try to balance the card with the point M placed at the tip of your fore finger. What do you notice about the state of equilibrium of the card? Suggest a reason for this observation.

From Activity 4.2 you should have observed that the cardboard balances horizontally at point M only. This shows that although the mass of the cardboard is distributed over the whole body, there is a particular point, M, where the

whole weight of the cardboard appears to be concentrated. When pivoted at this point the cardboard balances horizontally. This point, M, is called *centre of gravity* of the cardboard.

The centre of gravity of a body is the point from which the whole weight of the body appears to act.

The centre of gravity of an object is constant i.e. at the one location when a body is in a place with uniform gravitational field strength.

However, the centre of gravity of a body moves to a different location when the body is placed in a region with non-uniform gravitational field strength.

Centre of mass of an object on the other hand is the point where all the mass of the object is concentrated.

Since the mass of an object is constant and is not affected by pull of gravity, the location of the centre of mass of an object is constant i.e. does not change.

In places like on earth where the gravitational field strength is uniform, the centre of mass and the centre of gravity coincide i.e. are at the same point.

However, the two centres are at different locations for the same object if the object is placed in a place with non-uniform gravitational field strength.

4.2 Centre of gravity (c.g) of regular lamina

Activity 4.3

To locate the centre of gravity of a regular lamina

(Work in groups)

Materials: manila paper, ruler, pencil

Instructions

1. In this activity you will conduct an investigation to locate centre of gravity of a regular lamina.
2. Using your geometrical instruments, and the other materials provided, come up with a method of determining the centre of gravity of a regular lamina. Write a brief procedure and execute it.
3. Balance them at their centres of gravity on the tip of your pencil.
4. Practically locate their centres of gravities by drawing.

In the previous topic, you did Activity 3.6 on determining the weight of a beam. (uniform metre ruler). You were able to realise that the weight of the uniform metre rule tends to act at central point of the ruler that is at 50 cm mark. A thin cardboard like the one used in Activity 4.2 is a *lamina*. The cover of a book is a lamina. The

set square or protractor in your mathematical set are all examples of laminae.

Experiments have shown that bodies with *uniform cross-section area and density* have their centres of gravity located at their *geometrical centres*. For example, a metre rule of uniform cross-sectional area and density has its centre of gravity located at the 50 cm mark.

Fig. 4.3(a) - (d) shows the centre of gravity (c.g) of rectangular, square, triangular, and circular laminae.

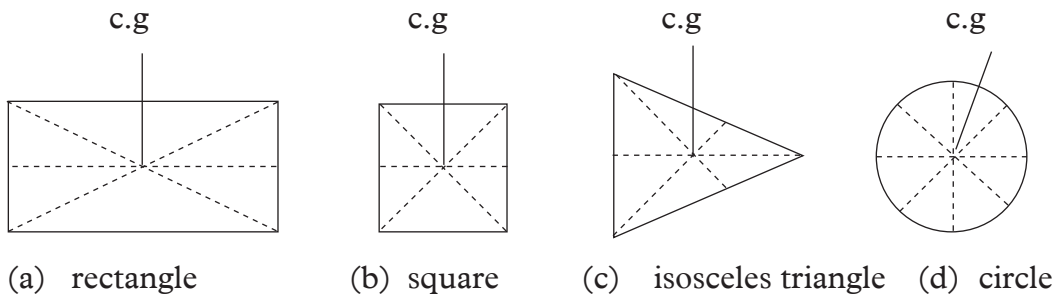

Fig. 4.3: c.g. of regular lamina

4.3 Centre of gravity (c.g) of irregular lamina

Activity 4.4

To determine the centre of mass of an irregular lamina using a plumbline

(Work in groups)

Materials: An irregular lamina, plumbline, a drawing pin

Steps

1. Guess and mark the centre of gravity of an irregular lamina.
2. Make three holes P, Q and R on an irregularly shaped lamina as close as possible to the edges and far away from each other. The holes should be large enough to allow the lamina turn freely when supported through a drawing pin.
3. Suspend the lamina on the clamp using the drawing pin through each hole at a time.
4. Suspend a plumbline (a thin thread with a small weight at one end) from the point of support, P as shown in Fig. 4.4(a), and draw the line of the plumbline on the lamina by marking two points A and B far apart and joining them.
5. Repeat the steps with the support Q and mark the point M where the two lines intersect.
6. Check the accuracy of your method by suspending the lamina at R. What do you observe? Explain.
7. Compare the c.g determined experimentally and that you guessed earlier.

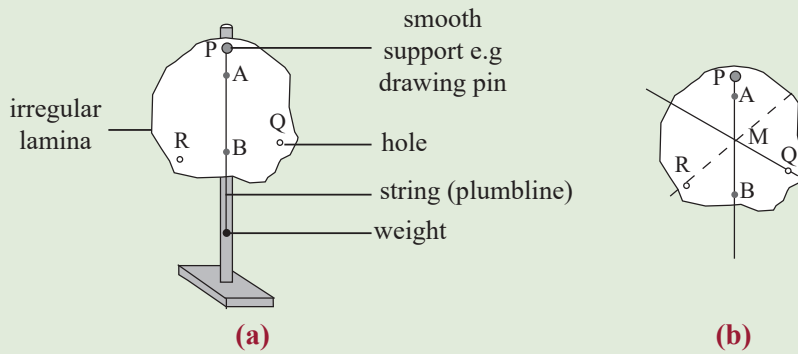

Fig. 4.4: Locating centre of mass of a lamina using a plumbline

- The plumbline pass through M (Fig. 4.4 (b)). Check the results again by balancing the lamina about point M. What do you observe?

The lamina balances horizontally at point M. Point M is the centre of gravity of the lamina.

This activity proves that *when a body is freely suspended it rests with its centre of gravity vertically below the point of suspension.*

Activity 4.5

To demonstrate how to locate the centre of gravity of an irregular object using a straight edge

(Work in groups)

Materials: An irregular lamina, a prism

Steps

- Balance a lamina on the edge PQ of a prism as shown in Fig. 4.5(a). Mark the points A and B on the lamina and join them.
- Repeat the activity for another position and note the points C and D on the lamina. Join C and D.

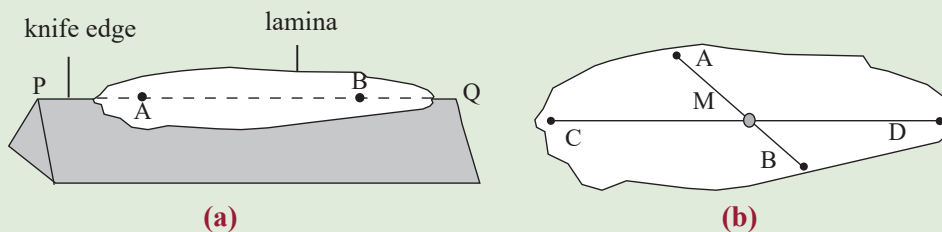

Fig. 4.5: Locating the centre of mass of a lamina using a straight edge

- Label the point of intersection of lines AB and CD as point M.
- Try balancing the lamina at point M on a sharp pointed support. What do you observe? Explain.

From Activity 4.5, you should have observed that the lines AB and CD intersect at M; the centre of gravity of the lamina.

4.4 Effect of position of centre of gravity on the state of equilibrium of a body

Activity 4.6

To define and describe three states of equilibrium

(Work in groups)

Materials: Internet, reference books

Steps

1. Conduct a research from books and the internet on the meaning of the term equilibrium in regard to forces acting on an object.
2. State the three states of equilibrium.
3. Describe each of the three states of equilibrium.
4. Compare and discuss your findings with other groups in class.

In your discussion, you should have noted that, the state of balance of a body is referred to as the *stability* of the body. Some bodies are in a more stable (balanced) state than others. The state of balance of a body is also called its *state of equilibrium*. Activities 4.7, will help us distinguish between the different states of equilibrium.

4.4.1 States of equilibrium

Activity 4.7

To investigate the three states of equilibrium

(Work in groups)

Materials: plastic thistle funnel, bench

Steps

1. Place the funnel upright with the wider mouth resting on the bench (Fig 4.6).
2. Displace the funnel slightly upwards as shown in Fig 4.6 (b) and then release it. What do you observe?

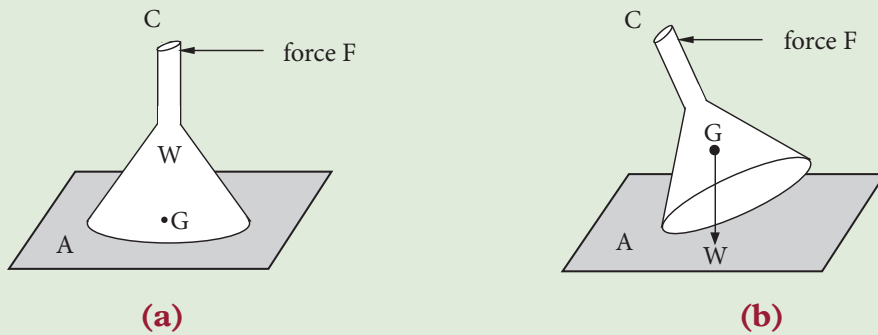

Fig 4.6: To show stable state

3. Explain the behaviour of the funnel in terms of the changes in the position of centre of gravity.
4. Place the funnel upright with the narrower mouth resting on the bench as shown in Fig 4.7 (a).
5. Displace the funnel slightly with your finger. What about change of state of the funnel?

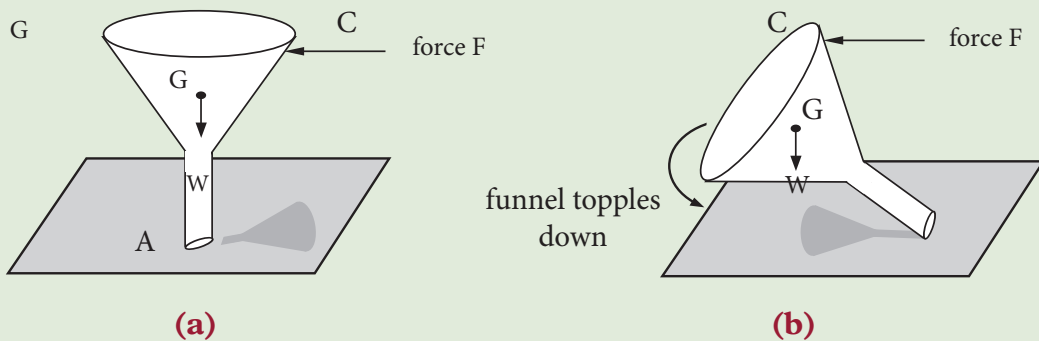

Fig 4.7: To show unstable state

6. Explain the behaviour of the funnel in terms of the change in position of its centre of gravity in this activity.
7. Place the funnel horizontally as shown in Fig 4.8 (a).
8. Displace the funnel gently by tapping it with a finger. What do you observe?

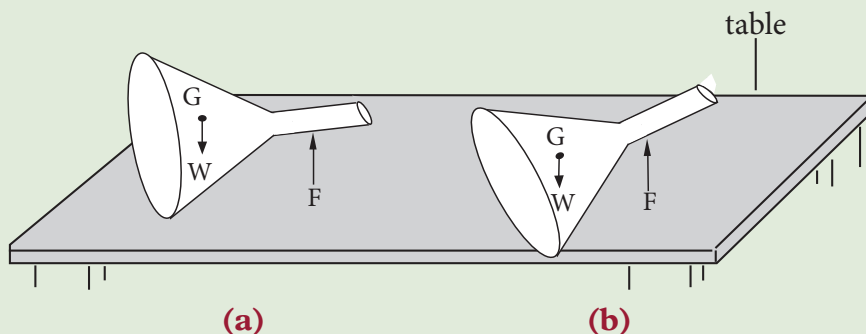

Fig. 4.8: To show neutral state

9. Explain the behaviour of the funnel in terms of the change in position of the centre of gravity when displaced slightly.

When a body is resting with its centre of gravity at the lowest point, it is **very stable**. When displaced slightly; its centre of gravity is raised and when it is released, the object falls back to its original position to keep its centre of gravity as low as possible. This type of equilibrium is known as **stable equilibrium**. Thus, the funnel in Activity 4.7 Fig. 4.6 (a) was in stable equilibrium.

Our finances and keeping the environment clean!!

Note that we have used a plastic thistle funnel instead of a glass one. The latter has high chances of breaking.

Any time we break a laboratory apparatus, we think of its effects on the school finances as it has to be replaced. Sometimes we may be required to pay ourselves hence affecting the finances of our parents.

In case you use glass funnels, be careful when using them. As they may break and cause injuries to you or group members. If it breaks accidentally, collect the broken pieces and dispose them to keep the environment clean.

When an object is resting with its centre of gravity at a very high position from the base support, it is **unstable**. When displaced slightly, it continues to fall up to the lowest possible position in order to lower its centre of gravity. This state of stability is known as **unstable equilibrium**. The funnel in Fig 4. 7(a) was in unstable equilibrium.

When an object is resting such that the position of its centre of gravity remains at the same vertical position even when the object is displaced, it is said to be in **neutral equilibrium**. The funnel in Fig 4.8 (a) was in neutral equilibrium.

4.4.2 Relationship between position of centre of gravity and stability

Activity 4.8

To investigate the relationship between position of centre of gravity of a body and its stability

(Work in pairs or groups)

Material: reference material

Discuss with your group members why:

1. Buses sometimes carry heavy luggage at their roof tops.
2. Buses have their luggage bonnets located underneath.
3. A person carrying two buckets full of water is more stable than one carrying one bucket.

4. Discuss and compare your explanations with your partner and report to the whole class.

A body is more stable when its heavy part is as low as possible since it lowers the position of the centre of gravity. If the heavy part of the body is at high position or if the light part of the body in high position is made heavier than the lower position, the body becomes unstable and thus likely to topple over and can cause accidents like in the case of a vehicle carrying heavy luggage at its roof top.

Exercise 4.1

1. Draw the figures below in your notebook and identify the centre of gravity of each.

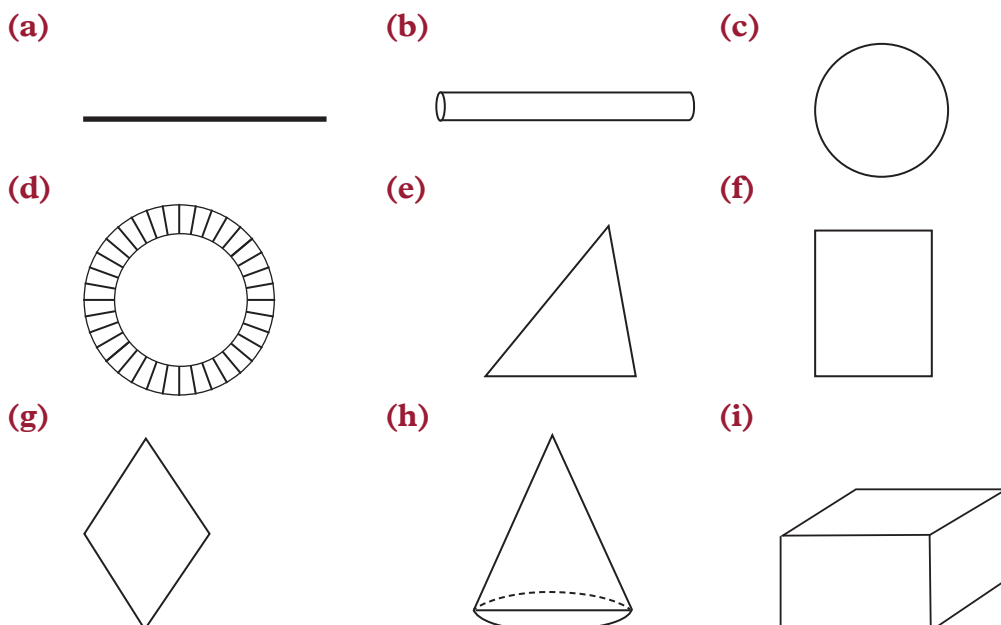

Fig 4.9: Various types of figures

2. Fig 4.10 shows a Bunsen burner at different states of equilibrium.

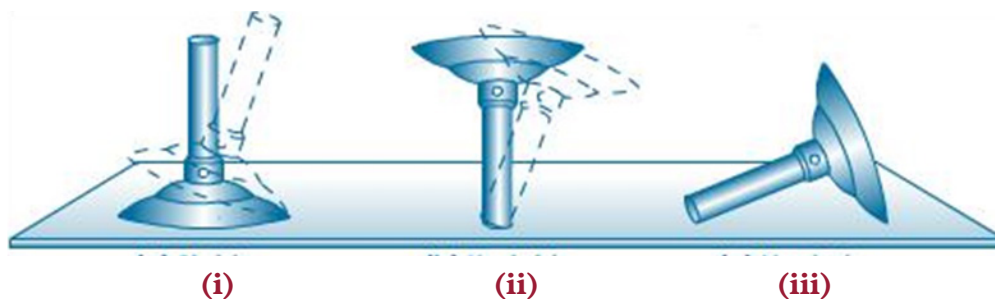

Fig 4.10: A bunsen burner at different states of equilibrium

- (a) Name the states in which the Bunsen burner is at in (i), (ii) and (iii).
 - (b) Describe each state named in (a) above.
3. With aid of a diagram, describe how you can determine the centre of gravity of an irregular plane sheet of metal.
 4. State and explain the states of equilibrium in Fig 4.11.

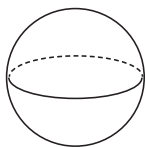

Fig 4.11: A sphere

4.5 Factors affecting the stability of a body

Activity 4.9

To design and investigate factors that affect the stability of a body

(Work in groups)

Materials: Plastic thistle funnels, Benches

Instructions

1. By modifying the set-up, we used in Activity 4.7, using the materials provided, conduct an investigation on factors affecting stability of a body.
2. Sketch the step-up and write a brief procedure to investigate the factors.
3. Execute the procedure and answer the following questions
 - (a) What happens to the funnel when the vertical line through the centre of gravity falls outside the base of the funnel? Deduce the factors that affect stability of the funnel.
4. Write a report and present it in a class discussions.
5. What are some of the sources of errors in the experiment and how can they be minimised?

The funnel is more stable when its c.g is at a very low position and vice versa. In addition, the activities show that the wider the base the more stable a body is. Activity 4.9 further shows that the funnel becomes unstable when the vertical line drawn through the centre of gravity falls outside the base that supports the body.



In summary, a body is more stable if:

1. the centre of gravity is as low as possible.
2. the area of the base is as large as possible, and
3. the vertical line drawn from the centre of gravity falls within its base.

4.6 Applications of the position of centre of gravity

Activity 4.10

To describe the applications of the position centre of gravity

(Work in groups)

Materials: reference books, Internet

Steps

1. Conduct a research from Internet and reference books on the applications of position of centre of gravity.
2. In your research also find out:
 - (a) Why a bird toy balances on its beak?
 - (b) Why it is not advisable to stand on a small boat on the surface of the water?
 - (c) Why one leans to the opposite direction when carrying a load?
 - (d) Why the bus chassis is made heavier than the other parts of the bus?
 - (e) How a tight-rope walker balances himself/herself?
3. Discuss your findings with other groups in class. Do you have the same explanations?
4. Have a class presentation on your findings from your research.

In your research and discussion, you should have learnt the following:

1. The **balancing bird** is a toy that has its centre of gravity located at the tip of the beak. The bird balances with its beak resting on one finger or any other support placed underneath the beak, and the rest of the body in the air. This is because it is designed with its centre of gravity at that point (Fig 4.12).

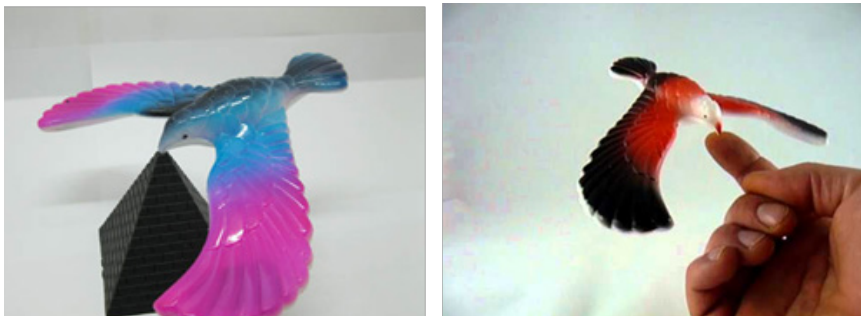

Fig. 4.12: Balancing bird toy

2. People in a small boat are advised neither to stand up nor lean over the sides while in the boat. This is because when they stand, they raise the position of the centre of gravity making the boat unstable and more likely to tip over (See Fig 4.13).

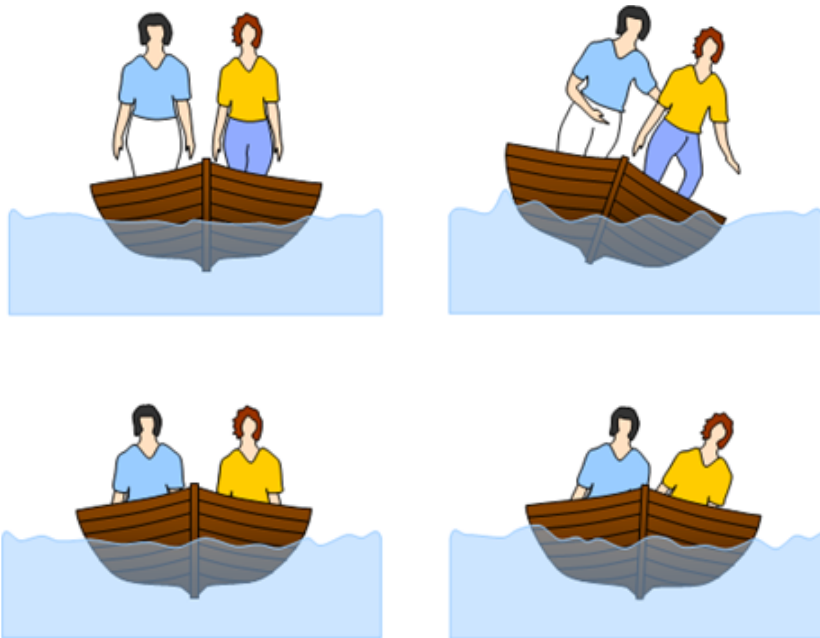

Fig. 4.13: People in a boat

3. A person normally leans to the opposite direction when carrying heavy loads with one hand e.g. a bucket full water. This helps to maintain the position of the c.g to within the base of the person in order to maintain stability (See Fig 4.14)

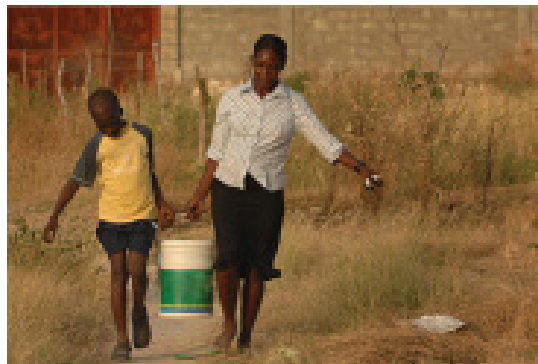

Fig. 4.14: Leaning while carrying heavy load

4. Most buses have their cargo in compartment in the basement instead of the roof rack in order to keep the centre of gravity of the buses as low as possible (Fig. 4.15).



Fig. 4.15: Buses carry their cargo below passengers' level.

5. A tight-rope walker carries a pole to maintain stability. By swaying from side to side, he/she ensures that the vertical line drawn from his/her centre of gravity falls within the feet on the rope in order to maintain stability. (Fig. 4.16).

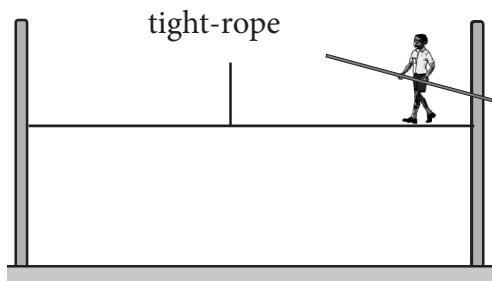

Fig. 4.16: A tight-rope walker carries a pole to maintain balance.

Topic summary

- The **centre of gravity, c. g.**, of a body is the point where the whole weight of the body appears to act from.
- **Centre of mass** of an objects is the point where all the mass of the object is concentrated.
- The centre of gravity of a regular lamina or object is at its geometric centre.
- The centre of gravity of a lamina can be found using a plumbline or by balancing it on a knife edge.
- A body is said to be in **stable equilibrium** if it returns to its original position after being displaced slightly.
- A body is in **unstable equilibrium** if on being slightly displaced, it does not return to its original position.
- A body is said to be in **neutral equilibrium** it moves to a new position but maintains the position of the c.o.g above its base support.
- Bodies can be made more stable if their centres of gravity are made as low as possible and the bases are made as broad as possible.

Topic Test 4

1. Define the term centre of gravity?.
2. Differentiate between centre of mass and centre of gravity.
3. Redraw the figures shown in Fig 4.17 below and indicate their centres of gravity.

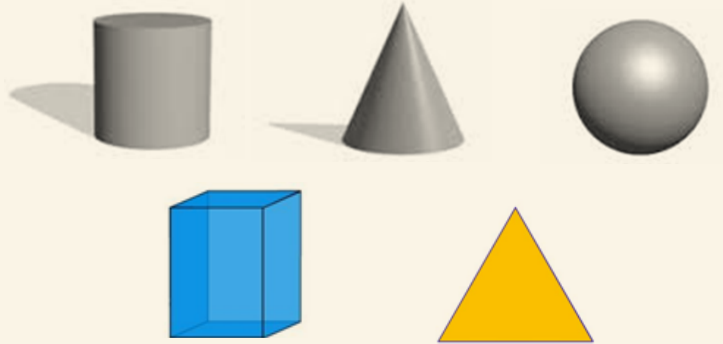

Fig. 4.17: Solids

4. Describe how you can determine the centre of gravity of the lamina shown in Fig 4.18.



Fig. 4.18: Irregular shape

5. Fig. 4.19 shows a marble in three types of equilibrium. State and explain the type of equilibrium in each case.



Fig. 4.19: Marble in three state of equilibrium

6. What is stability?
7. One vehicle which was travelling from Juba to Gulu was seen carrying heavy goods on its roof top and some of its passengers in the vehicle were standing. Discuss why the vehicle is likely to topple if it negotiates a corner at high speed.

8. Explain why a three-legged stool design is less stable than a four legged one.
9. Explain the following:
 - (a) The passengers of a double-decker bus are not allowed to stand on the upper deck.
 - (b) A racing car is made of a heavy chassis in its lower parts.
 - (c) When one is alighting from a moving vehicle, it is advisable to spread out his/her legs.

My safety



Do not stand in a moving vehicle. Let us observe traffic rules.

Topics in the unit

Topic 5: Work, Energy and Power

Learning outcomes**Knowledge and Understanding**

- Understand the concepts of work, energy and power.

Skills

- Design tests to relate work done to the magnitude of a force and the distance moved, power to work done and time taken, using appropriate examples.
- Observe carefully.
- Predict what might happen.
- Use appropriate measures.
- Collect and present results appropriate in writing or drawing.
- Interpret results accurately and derive kinetic and potential energy formula.
- Report findings appropriately and relate work, energy and power.

Attitudes

- Appreciate that food eaten is energy.

Key inquiry questions

- How does the world get its energy?
- Why is energy not destroyed?
- Why work done is energy?

Unit outline ▶▶▶

- Forms of energy
- Transformation of kinetic energy to potential energy and vice versa.
- Sources of energy
- Different ways to conserve energy
- Law of conservation of mechanical energy

Introduction

Everyday, we do many types of work. We work in the offices, in the farms, in the factories etc. To make our work easier, we use machines ranging from simple tools to sophisticated machinery. Different machines or people do work at different rates (known as power). The ability and the rate of doing certain amount of work depends on how much energy is used. In this topic, we will seek to understand these three terms i.e work, energy and power from the science point of view.

5.1 Work**Activity 5.1**

To distinguish cases when work as defined in science is done or not

(Work individually or in groups)

Materials: a chart showing people carrying out different activities, pieces of chalk, pen, chair, desk.

Steps

1. Conduct research from books on the scientific definition of work.
2. Walk from your chair to the chalkboard and write the word 'work' on the chalkboard.
3. Collect any litter in your classroom.

Be responsible

Always keep where you live clean. It is good for your health.

4. Carry your chair to the front of your classroom and sit on it.
5. Push against a rigid wall of your classroom.
6. Discuss with your colleagues whether scientifically speaking work, is done in steps 1, 2, 3 and 4. What do think is the meaning of 'work' ?
7. Now, look at the activities being performed by the people in Fig. 5.1 below.



(a)



(b)



(c)



(d)

Fig. 5.1: People performing different tasks

8. According to the scientific definition of work, in which of the diagrams above is the person doing work? Explain.
9. Give other examples of doing work.

Work is only said to have been done when an applied force moves the object through some distance in the direction of force. Therefore in Activity 5.1, work was done in steps 2, 3 and part of 4 (when carrying the desk). However, no work was done when you sat on your chair without moving in step 4 and pushing the wall without moving it in step 5.

Similarly, in Fig 5.1, work is being done in (a) and (d) only. When the girl applies a force to a wall in (b) and even becomes exhausted, she is not doing any work because the wall is not displaced. When the woman carries the basket on the head, she is not doing any work. This is because she exerts an upward force on the basket which is balanced by the weight hence there is no motion of the basket in the direction of the applied force.

Definition of work

Work is defined as the product of force and distance moved in the direction of the force. i.e

Work = force \times distance moved in the direction of the force

$$W = F \times d$$

The SI unit of work is joule (J).

A joule is the work done when a force of 1 newton moves a body through a distance of 1 metre.

1 joule = 1 newton \times 1 metre

Bigger units used are kilojoules (1 kJ) = 1 000 J

Megajoule (1 MJ) = 1 000 000 J

Note: Whenever work is done, energy is transferred.

Example 5.1

Find the work done in lifting a mass of 2 kg vertically upwards through 10 m. ($g = 10 \text{ m/s}^2$)

Solution

To lift the mass upwards against gravity, a force equal to its own weight is exerted.

Applied force = weight = $mg = 2\text{kg} \times 10\text{N/kg} = 20 \text{ N}$

Work done = $F \times d = 20 \text{ N} \times 10 \text{ m}$

= 200 Nm

= 200 J

5.1.1 Work done in pulling an object along a horizontal surface

Activity 5.2

To design an investigation to determine the work done in pulling an object along a horizontal surface

(Work in groups)

Materials: a block, a weighing scale, and a tape measure/metre ruler, string.

Instructions

1. In this experiment you will design and carry out an investigation to determine work done in pulling an object on a horizontal surface.
2. Using the materials provided think of a set-up to do the investigation. Set-up the apparatus and sketch the set-up.
3. Write a brief procedure to execute in doing the activity.
4. Correctly execute the procedure and answer the following questions.
5. Using relevant formula, calculate the work done in pulling the block. What assumption did you make? Explain.
6. Compare and discuss your findings with other groups in class.
7. Explain how tractors pull large loads.

Since the block was on a smooth surface, we assume that friction force is negligible hence the force applied is constant along the distance of motion, d .

Work done in moving the block is given by:

Work = force \times distance

$$W = F \times d = Fd$$

Example 5.2

A horizontal pulling force of 60 N is applied through a spring to a block on a frictionless table, causing the block to move by a distance of 3 m in the direction of the force. Find the work done by the force.

Solution

$$\begin{aligned}\text{The work done} &= F \times d = 60 \text{ N} \times 3 \text{ m} \\ &= 180 \text{ Nm} \\ &= 180 \text{ J}\end{aligned}$$

Example 5.3

A horizontal force of 75 N is applied on a body on a frictionless surface. The body moves a horizontal distance of 9.6 m. Calculate the work done on the body.

Solution

$$\begin{aligned}\text{Work} &= \text{force} \times \text{distance} \\ &= 75 \text{ N} \times 9.6 \text{ m} \\ &= 75 \times 9.6 \text{ Nm} \\ &= 720 \text{ J}\end{aligned}$$

Example 5.4

A towing truck was used to tow a broken car through a distance of 30 m. The tension in the towing chain was 2 000 N. If the total friction is 150 N, determine.

- (a) Work done by the pulling force.
- (b) Work done against friction.
- (c) Useful work done.

Solution

Fig. 5.2 shows the forces acting on the two cars.

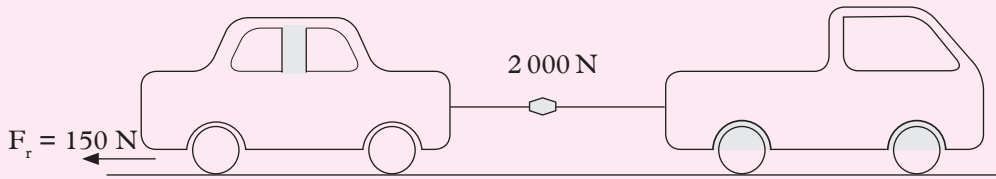

Fig. 5.2: Diagram of cars

- (a) Work done by the pulling force
 $W = F \times d$
 $= 2\,000\text{ N} \times 30\text{ m}$
 $= 60\,000\text{ J}$
- (b) Work done against friction
 $W = F_r \times d$ (F_r is the frictional force)
 $= 150\text{ N} \times 30\text{ m}$
 $= 4\,500\text{ J}$
- (c) Useful work done
Useful work done $= Fd - F_r d$
 $= (60\,000 - 4\,500)\text{ J}$
 $= 55\,500\text{ J}$

Exercise 5.1

1. Explain why in trying to push a rigid wall, a person is said to be doing no work.
2. Define the term work and state its SI unit.
3. How much work is required to lift a 2 kilogram mass to a height of 10 metres (Take $g=10\text{ m/s}^2$).
4. A garden tractor drags a plough with a force of 500 N at a distance of 2 metres in 20 seconds. How much work is done?

5.1.2 Work done against the force of gravity

Activity 5.3

To determine the work done against the force of gravity

(Work in pairs)

Materials: Masses, meter rule (tape measure), a single fixed pulley, string, retort stand, newtonmeter.

Steps

1. Hang a mass from a newtonmeter and record its weight.
2. Lift a mass from the ground or bench vertically upwards at a constant speed up to a certain point. For a pulley, tie the string on a mass and pass it around the pulley / clamped on a retort stand pull the other end of the thread. Explain why you must use some work in lifting a mass from the ground.
3. Have a friend to measure the height through which the mass has been raised using the meter ruler or tape measure.
4. The force needed to lift the mass is equal to its weight mg .
5. The work done on the mass is then $w = Fd = mgh$.
6. Repeat the steps with different masses and calculate the work.
7. When an object is thrown upwards, it raises upto a certain point and then drops. Explain why it raises and drops back. You can do this practically by throwing some objects (of different masses). Approximate amount of work done.

The gravitational force (weight) acting on a body of mass m is equal to the product of mass and acceleration due to gravity, g , i.e. $w = mg$.

Thus, to lift a body, work has to be done against the force of gravity (Fig. 5.3).

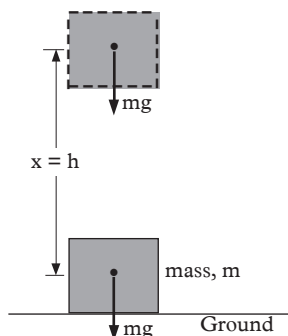

Fig 5.3: Work done against gravity

Work done against gravity to lift a body through height is given by:

$$\begin{aligned}\text{Work} &= \text{Force} \times \text{vertical height} \\ &= mg \times h = mgh\end{aligned}$$

Example 5.5

Calculate the work done by a weight lifter in raising a weight of 400 N through a vertical distance of 1.4 m.

Solution

$$\begin{aligned}\text{Work done against gravity} &= \text{Force} \times \text{displacement} \\ &= mg \times h = 400 \text{ N} \times 1.4 \text{ m} \\ &= 560 \text{ J}\end{aligned}$$

Example 5.6

A force of 200 N was applied to move a log of wood through a distance of 10 m. Calculate the work done on the log.

Solution

$$\begin{aligned}W &= F \times d \\ &= 200 \text{ N} \times 10 \text{ m} \\ &= 2\,000 \text{ J}\end{aligned}$$

Exercise 5.2

1. Define work done and give its SI unit.
2. Calculate the work done by a force of 12 N when it moves a body through a distance of 15 m in the direction of that force.
3. Determine the work done by a person pulling a bucket of mass 10 kg steadily from the well through a distance of 15 m.
4. A car moves with uniform speed through a distance of 40 m and the net resistive force acting on the car is 3 000 N.
 - (a) What is the forward driving force acting on the car? Explain your answer.
 - (b) Calculate the work done by the driving force.
 - (c) State the useful work done.
5. A student of mass 50 kg climbs a staircase of vertical height 6 m. Calculate the work done by the student.
6. A block was pushed by a force of 20 N through 9 m. Calculate the work done.

5.1.3 Work done along an inclined plane

Activity 5.4

To determine the work done along an inclined plane

(Work in groups)

Materials

Spring balance, one piece of wood of about 10 cm, a wedge, ruler, trolley/ piece of wood/mass hanger/stone.

Steps

1. Make an inclined plane by putting a piece of wood on a wedge.
2. Attach the mass hanger/stone/trolley to a spring balance (calibrated in Newtons). What happens to the spring immediately when the mass is hanged on it?
3. Measure the length of the incline and record it down $l = \dots$ cm.
4. Pull the spring balance with its object on from the bottom of the incline and note down the force used in pulling.N
5. Change the length in cm to m and find the work done using the formula, $work = Fd = (J)$
6. Using the above skills, approximate the amount of work you do when climbing a slope of 100 m long.

Consider an inclined plane as shown in Fig. 5.4 below. A body of mass m moved up by a force f through a distance d .

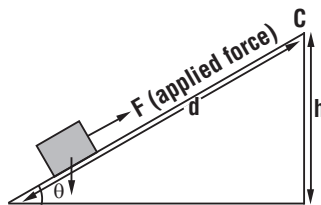

Fig. 5.4: Work done along inclined plane.

Work done by the applied force is given by

$$\text{Work done} = F \times d$$

The work done against the gravitational force is given by:

$$\text{Work done} = \text{weight of the object} \times \text{vertical height}$$

$$\text{Work} = mgh$$

In case the inclined plane is frictionless force:

Work done by the applied force = work done against gravity

In case there is some frictional force opposing the sliding of the object along the plane:

Work done by the applied force > Work done against gravity

Work done against friction = Work done by applied force – work done against gravity

Example 5.7

A box of mass 100 kg is pushed by a force of 920 N up an inclined plane of length 10 m. The box is raised through a vertical distance of 6 m (Fig. 5.5).

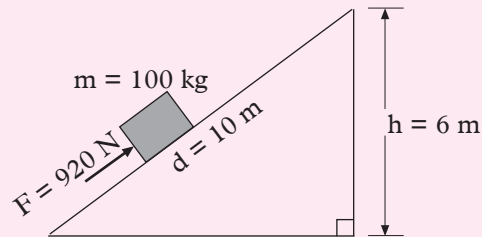

Fig 5.5: Inclined plane

- (a) Calculate:
- (i) the work done by the applied force,
 - (ii) the work done against the gravitational force.
 - (iii) the difference in work done.
- (b) Why do the answers to (i) and (ii) in part (a) differ?

Solution

- (a) (i) Work done by the applied force

$$\begin{aligned} &= F \times d \\ &= 920 \text{ N} \times 10 \text{ m} \\ &= 9\,200 \text{ J} \end{aligned}$$

(ii) Work done against gravity

$$\begin{aligned} &= F \times d \\ &= mg \times h \\ &= 100 \text{ kg} \times 10 \text{ N/kg} \times 6 \text{ m} \\ &= 6\,000 \text{ J} \end{aligned}$$

(iii) The difference in work done

$$\begin{aligned} &= 9\,200 \text{ J} - 6\,000 \text{ J} \\ &= 3\,200 \text{ J} \end{aligned}$$

- (b) This work done is used to overcome the friction between the box and surface of the incline plane. The useful work done is 6 000 N.

Exercise 5.3

1. A box of mass 50 kg is pushed with a uniform speed by a force of 200 N up an inclined plane of length 20 m to a vertical height for 8 m (Fig. 5.6).

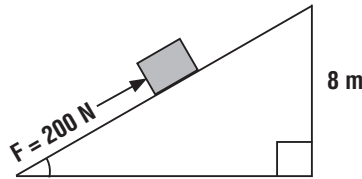

Fig. 5.6: Work done along an inclined plane

Calculate the:

- (a) Work done to move the box up the inclined plane.
(b) Work done if the box was lifted vertically upwards.
2. A body of mass 85 kg is raised through a vertical height 6 m through an inclined plane as shown in Fig. 5.7.

Calculate the:

- (a) Slant distance.
(b) Work done by the force 150 N.
(c) Work done, if the body was lifted vertically upwards.
(d) Work done against friction.
(e) Frictional force between the body and the track.
3. A block of mass 60 kg was raised through a vertical height of 7 m. If the slant height of a frictionless track is 21 m, and the force used to push the block up the plane is 800 N, calculate the work done in pushing the block.
4. A car engine offers a thrust of 2 500 N to ascend a sloppy road for 1.1 km. At the top of the slope, the driver realized that the attitude change was 200 m. If the mass of the car is 1.2 tonnes, calculate the;
- (a) Work done by the car engine.
(b) Work done against resistance.

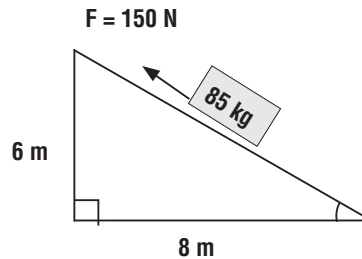

Fig. 5.7: Work done on an inclined

5.2 Power

Activity 5.5

To compare the time taken to do a piece of work by a person and a machine

(Work in groups)

Materials: writing material, stopwatch and scientific calculator.

Steps

1. By timing yourself, start solving the following problems without using calculator:
 - (a) $37\,6998\text{ J} \times 276\text{ J}$
 - (b) $35\,264\text{ J} \times 469\text{ J}$
2. Repeat step 1, but now with a scientific calculator and compare the time taken. Which one takes longer or shorter time to complete the task? Explain your answer.
3. Now, think of a man ploughing a square piece of land that measure 100 m by 100 m (a) by hand, (b) using a tractor. Which task do you think takes longer or shorter time to complete the activity? Suggest a reason.
4. What is power? In your groups discuss the meaning of power.

In your discussion, you might have noted that sometimes work is done very quickly and sometimes very slowly. For instance, it takes a longer time to multiply the problems without a calculator in step 1 than with a calculator in step 2. Similarly, in step 3, a tractor will take few hours ploughing a piece of land while a man will take more hours ploughing the same piece of land. The person and the tractor are doing the same work but the tractor is doing it at a faster rate than the person does. This is because they have different power ratings.

Different machines and engines have different power ratings. Engines with bigger power ratings are said to be powerful and operate very fast.

Definition of power

Power is the rate of doing work. i.e.

$$\text{Power} = \frac{\text{work done}}{\text{time taken}} = \frac{\text{force} \times \text{distance}}{\text{time}}$$

SI units of power are **Watts**.

$$1 \text{ watt} = 1 \frac{\text{joule}}{\text{second}}$$

Large units used are kilowatt and megawatt.

$$1 \text{ kilowatt} = 1\,000 \text{ W}$$

$$1 \text{ megawatt} = 1\,000\,000 \text{ W}$$

Example 5.8

What is the power of a boy lifting a 300 N block through 10 m in 10 s ?

Solution

Force = 300 N, Distance = 10 m, Time = 10 s

$$\begin{aligned} \text{Work done by the boy} = F \times d &= 300 \times 10 \\ &= 3\,000 \text{ J} \end{aligned}$$

$$\begin{aligned} \text{Power} = \frac{\text{work}}{\text{time}} &= \frac{3\,000 \text{ J}}{10 \text{ s}} \\ &= 300 \text{ W} \end{aligned}$$

5.2.1 Estimating the power of an individual climbing a flight of stairs

Activity 5.6

To estimate the power of an individual climbing a flight of stairs

(Work in groups)

Materials: stopwatch, weighing machine, tape measure

Steps

1. Find a set of stairs that you can safely walk and run up. If there are no stairs in your school, create some at garden.
2. Count their number, measure the vertical height of each stair and then find the total height of the stairs in metres.
3. Let one member weigh himself/herself on a weighing machine and record the weight down.
4. Let him/her walk then run up the stairs. Using a stopwatch, record the time taken in seconds to walk and running up the stairs (Fig 5.8).



Fig. 5.8: Measuring one's own power output

5. Calculate the work done in walking and running up the stairs. Let each group member do the activity. Is the work done by different members in walking and running up the stairs same? Explain the disparity of work done by various group members.
6. Calculate the power developed by each individual in walking and running up the stairs. Which one required more power, walking or running up the flight of stairs? Why?

Note:



- (i) The disabled should be the ones to time others. Care must be taken on the stairs not to injure yourselves.
- (ii) In case of lack of stairs, learners can perform other activities like lifting measured weights.

From your discussion, you should have established that:

Height moved up (h) = Number of steps (n) \times height of one step (x)

$$h = n \times x$$

$$= n x$$

Time taken to move height (h) = t

$$P = \frac{\text{Work done against gravity}}{\text{time}} = \frac{mgh}{t} = \frac{W \times h}{t}$$

$$= \frac{W \times n \times x}{t}$$

$$P = \frac{Wnx}{t}$$

where, P = power, W = weight, x = height of first step, n = number of steps

If x is in metres, W in newtons and t in seconds then power is in **watts**.

Example 5.9

A girl whose mass is 60 kg can run up a flight of 35 steps each of 10 cm high in 4 seconds. Find the power of the girl. (Take $g = 10 \text{ m/s}^2$).

Solution

$$\begin{aligned}\text{Force overcome (weight)} &= mg \\ &= 60 \text{ kg} \times 10 \text{ N/kg} \\ &= 600 \text{ N}\end{aligned}$$

$$\text{Total distance} = 10 \times 35 = 350 \text{ cm} = 3.5 \text{ m}$$

$$\begin{aligned}\text{Work done by the girl} &= F \times d = 600 \times 3.5 \\ &= 2100 \text{ J}\end{aligned}$$

$$\text{Power} = \frac{\text{work}}{\text{time}} = \frac{2100 \text{ J}}{4 \text{ s}}$$

The power of the girl is 525 W

My health



Do you know that regular exercises are good for your health.
Do exercises regularly to keep your body healthy

Exercise 5.4

1. Define power and give its SI unit.
2. To lift a baby from a crib, 100 J of work is done. How much power is needed if the baby is lifted in 0.5 seconds.
3. If a runner's power is 250 W, how much work is done by the runner in 30 minutes?
4. The power produced by an electric motor is 700 W. How long will it take the motor to do 10,000 J of work?
5. Find the force a person exerts in pulling a wagon 20 m if 1500 J of work is done.
6. A car's engine produces 100 kW of power. How much work does the engine do in 5 seconds?
7. A color TV uses 120 W of power. How much energy does the TV use in 1 hour?
8. A machine is able to do 30 joules of work in 6.0 seconds. What is the power developed by the machine?

9. Rebecca is 42 kg. She takes 10 seconds to run up two flights of stairs to a landing, a total of 5.0 metres vertically above her starting point. What power does the girl develop during her run?
10. Student A lifts a 50 newton box from the floor to a height of 0.40 metres in 2.0 seconds. Student B lifts a 40 newton box from the floor to a height of 0.50 metres in 1.0 second. Which student has more power than the other?
11. Four machines do the amounts of work listed in Table 5.1 shown below. The time they take to do the work is also listed. Which machine develops the most power?

Machine	Work	Time
A	1 000 joules	5 sec
B	1 000 joules	10 sec
C	2 000 joules	5 sec
D	2 000 joules	10 sec

Table 5.1

5.3 Energy

Activity 5.7

To brainstorm about energy

(Work in pairs)

Materials: Reference materials, a pen, desk or slopy platform

Steps

1. What enables your body to perform various functions besides keeping warm. Discuss this with your group member.
2. Define the term energy.
3. Push a pen on your desk such that it rolls for a small distance. What makes the pen roll?
4. State some examples of objects that possess energy in our environment.
5. Discuss the importance of energy in our lives.
6. With a heavy bag on your back, climb the stairs to the top most floor or the steep ground to the top most point. How do you feel? Have you done work? Did you use energy to do so?
7. What happens to a car that has been moving if it runs out of fuel (petrol or diesel)? Explain.
8. Discuss the observations and findings from the above activities in a class discussion.

Energy is one of the most fundamental requirements of our universe. It moves motorcycles, cars along roads, airplanes through air, and boats over water. It warms and lights our homes, makes our bodies grow and allows our minds to think. A person is able to push a wheelbarrow, a stretched catapult when released is able to make a stone move, wind mills are turned by a strong wind and cooking using electricity in a cooker. All these are possible because of energy.

Therefore, for any work to be done, energy must be provided. But what is energy?

Definition of energy

Energy is the ability to do work.

Work done = energy transferred

SI unit of energy is joules (J).

Relationship between energy and work

In your discussion, you should have noted that you got exhausted because you did a lot of work against gravity to carry your body and the heavy bag to the top of the building. The work you did led to the loss of energy (chemical energy from the food) from your body.

5.4 Forms of energy

Energy is not visible, it occupies no space and has neither mass nor any other physical property that can describe it. However, it exists in many forms, some of these forms include:

5.4.1 Solar energy

Activity 5.8

To investigate the effect of solar energy

(Work in groups)

Materials: plastic basin, water, convex lens, thin piece of paper

Steps

1. On a bright sunny day, fill a plastic basin with cold water and place it in an open place with no shade. Dip your hand into the water after 2 hours. What is the temperature difference of the water initially and after 2 hours?
2. Get a convex lens on the same day and put it horizontally with one surface facing the sun and another surface facing down. Place a thin paper below the lens. What do you observe after 5 minutes or more?
3. Discuss your observations in steps 1 and 2.

The water becomes hot in case 1 and in case 2, the paper burns because of the heat from the sun. These are some of the effects of **solar energy**. This energy from the sun is in form of *radiant heat* and *light*. In some countries where the sun shines throughout, large concave mirrors have been set to collect energy from the sun by focusing its rays on special boilers which provide power for running electric generators.

5.4.2 Sound energy

Activity 5.9

To design and investigate the production of sound energy

(Work in pairs)

Materials: Two pens, a stone

Instructions

1. In this activity, design and carry out an investigation on production of sound energy using the materials provided.
2. Write a brief procedure and execute it to produce sound energy. Then write a report about your investigation and then discuss it in a class presentation.
3. In what form is the energy released by the pen and the stone? Discuss with your class partner.

From your discussion, you should have heard sound in steps 1 and 2. In each case, kinetic energy has been converted to sound and heat energy. **Sound energy** is the energy associated with the vibration or disturbance of bodies or matter.

5.4.3 Heat energy

Activity 5.10

To demonstrate heat energy

(Work in groups)

Materials: Bunsen burner/candle, matchbox, a retort stand, a nail/metallic rod

Steps

1. Light a Bunsen burner or a candle using a lighter (matchbox).
2. Clamp a nail (metallic rod) on a retort stand and bring it near the flame.
3. Carefully touch the other end of the nail after sometime. What do you feel? Explain.

The other end of the nail is felt to be hot after sometime. The hotness is due to heat energy that has been transferred from the hot part to the cold part of the nail. Therefore, heat energy only travels from a hot object to a cooler one.

Heat energy is a form of energy that is transferred from one body to another due to the difference in temperature.

5.4.4 Electrical energy

Activity 5.11

To demonstrate production of light by electrical energy

(Work in groups)

Materials: bulb, electric wire, cells (battery), switch, bulb holder and cell holder

Steps

1. Fix the battery/cells in their holders and the bulb too.
2. Connect one wire from one end of the cell holder to the bulb holder. Then connect the same wire from the bulb holder to the switch holder and then connect another wire from the other part/side of cell holder to the switch. Make sure the switch is open and the cells are fixed into their holder.
3. What do you observe after the connection? Explain.
4. Complete the circuit then close the switch and observe what happens.

The bulb lights when the circuit is complete. **Electrical energy** is the energy produced by the flow of electric charges (electrons). Work is done when electrons move from one point to another in an electric circuit with electrical appliances such as bulbs.

5.4.5 Nuclear energy

Activity 5.12

To find out what is nuclear energy

(Work in groups)

1. Conduct a research from internet and reference books on the meaning of nuclear energy.
2. In your research, also find out advantages and disadvantages of nuclear energy.
3. Compare and discuss your findings with those of other groups in your class. You may consult your teacher for more guidance on your discussion.

In your discussion, you should have noted that nuclear energy is the energy that results from nuclear reactions in the nucleus of an atom. It is released when the nuclei are combined or split.

5.4.6 Chemical energy

Activity 5.13

To investigate and demonstrate chemical energy

(Work in groups)

Materials: glass beaker, a small bowl, steel wool, white vinegar, thermometer

Steps

1. Place the steel wool in the bowl and soak it in white vinegar for a couple of minutes.
2. Squeeze out excess vinegar and wrap the steel wool around the thermometer in a way that you are still able to read the temperature.
3. Put the steel wool in the beaker, then place a cover with a paper or small book on the top.
4. Record the temperature immediately, then again in a minute or so, and again every minute for about five minutes. What did you observe?
5. Discuss your observation with other groups in a class discussion.

The thermometer records a higher temperature reading. The chemical reaction of vinegar and steel wool generates energy in form of heat. This causes temperature to rise as shown by the thermometer.

Chemical energy is a type of energy stored in the bonds of the atoms and molecules that make up a substance. Once chemical energy is released by a substance, it is transferred into a new substance. Food and fuels like coal, oil, and gas are stores of chemical energy. Fuels release their chemical energy when they are burnt in the engine (e.g in a car engine).

5.4.7 Mechanical energy

Activity 5.14

To describe mechanical energy

(Work in groups)

Materials: pen, a piece of chalk

Steps

1. Raise a piece of chalk or pen from the ground to a position above your head and release it to fall to the ground. What do you observe with the change in height and the speed of the piece of chalk as it falls.

2. Throw two full pieces of chalk on the wall one at a time using different forces or at different speeds (one should move faster and another one slowly). Note the sound created by the piece of chalk after colliding with the wall. Which one makes more noise after collision?

Mechanical energy is the energy possessed by a body due to its motion or due to its position. It can either be kinetic energy or potential energy or both. When an object is falling down through the air, it possesses both potential energy (PE) due to its position above the ground, and kinetic energy (KE) due to its speed as it falls. The sum of its PE and KE is its mechanical energy.

Mechanical energy = kinetic energy + potential energy.

(a) Potential energy

Activity 5.15

To demonstrate the forms of potential energy

(Work in pairs)

Materials: a catapult or a spring, a small stone.

Steps

1. Raise a small stone from the ground or any other resting position upwards to a particular height above its resting surface. What kind of energy do you think it attains?
2. Now, release the stone and observe what happens. Explain your observations.
3. Compress a spring to a particular size. What kind of energy do you think it attains? Explain.
4. Release the spring and observe what happens to the spring.
5. Why does the spring move in such a manner? Discuss your observations in steps 1, 2, 3 and 4 with your colleagues and identify two types of potential energy from the activities.

You should have observed that when the stone was released it moved down to the ground. This implies that the stone had stored energy due to its position that makes it to start moving down after it has been released.

The energy possessed by a body (e.g. a stone) due to its position above the ground is called **gravitational potential energy**.

In other words potential energy is *energy by virtue of position*.

Similarly, when the compressed spring was released, it relaxed to a bigger size. This implies that the spring had stored energy due to compression.

The energy possessed by a body due to compression (e.g. a spring) or stretch (e.g. catapult) is called **elastic potential energy**.

Therefore, potential energy is in two forms; gravitational potential energy and elastic potential energy.

(i) Gravitational potential energy

Bodies which are at a given height above the ground possess gravitational potential energy. This energy depends on the position of objects above the ground. The following activity will help us to understand how to calculate potential energy of a body at a particular position above the ground.

Activity 5.16

To determine gravitational potential energy of a raised object

(Work in pairs)

Materials: three bricks, meter ruler, beam balance, soft board bridge

Steps

1. Conduct research from the Internet and books on the mathematical expression of potential energy.
2. Support the soft board on two bricks.
3. Measure the mass of the third brick by using a beam balance then place it on the soft board.
4. Now lift the third brick to a height h_1 . Let your partner measure the height h_1 in metres.
5. Allow the brick to drop gently onto the soft board. Describe the energy possessed by the brick as it drops.
6. Calculate the potential energy gained by the stone using the expression of potential energy you got from the research.
7. Repeat the activity with the other two different heights h_2 and h_3 .
8. Compare and discuss your observations and values of PE in the three cases and deduce a general conclusion from your discussion.

If a stone is lifted upwards through a height h ; and placed on a table (Fig 5.9), work is done against gravity.

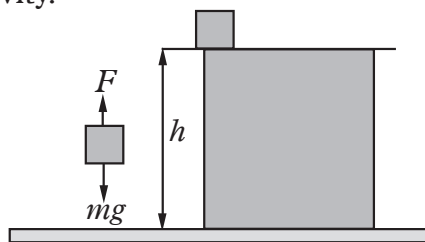

Fig. 5.9: Potential energy depends on height, h .

The work done to overcome gravity is equal to the gravitational potential energy gained by the stone.

But work done = $F \times h$; $F = mg$

\therefore work done = $mg \times h$

But, potential energy = work done.

Therefore: P.E = mgh

Example 5.10

A crane is used to lift a body of mass 30 kg through a vertical distance of 6.0 m.

- (a) How much work is done on the body?
- (b) What is the P.E stored in the body?
- (c) Comment on the two answers.

Solution

- (a) Work done = $F \times d = mg \times d = 30 \times 10 \times 6 = 300 \times 6 = 1\,800$ J
- (b) P.E = $mgh = 300 \times 6 = 1\,800$ J
- (c) The work done against gravity is stored as P.E in the body.

Caution



A stone dropped from the roof of a building will cause more pain if it falls on someone's foot than when the same stone falls from a table. This is because the one on the roof has more gravitation potential energy due to its greater height (position) above the ground.

(ii) Elastic potential energy

In Activity 5.15, we saw that a stretched catapult or compressed (Fig. 5.10(a)) has energy stored in form of elastic potential energy. When the stretched spring catapult is released it releases the energy that can be used to do work e.g. to throw a stone.

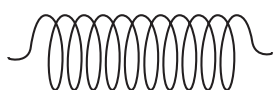

(a)

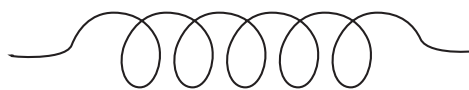

(b)

Fig. 5.10: A compressed and a stretched spring

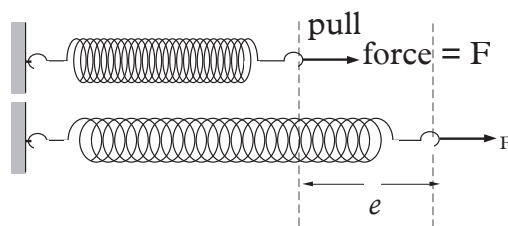

Fig.5.11: Elastic potential energy

$$\begin{aligned}
 \text{Work done in stretching the spring} &= \text{Elastic P.E gained by the spring} \\
 &= \text{average force} \times \text{extension} \\
 &= \left(\frac{0 + F}{2} \right) \times e \\
 &= \frac{1}{2} Fe
 \end{aligned}$$

Work done is stored as elastic potential energy.

Note: Since the force is not uniform (F increases from 0 to F) we should use the *average force* in calculating the work done.

Example 5.11

Calculate the elastic gravitational p.e stored in a spring when stretched through 4 cm by a force of 2 N.

Solution

$$\text{Elastic P.E} = \frac{1}{2} Fe = \frac{1}{2} \times 2 \times (0.04) = 0.04 \text{ J}$$

We will learn more about elastic potential energy and how to determine it later.

(b) Kinetic energy

Activity 5.17

To demonstrate kinetic energy

(Work in pairs)

Material: trolley, table

Steps

1. Place a trolley on the table and give it a slight push. Observe what happens to it. Explain your observations.
2. Now, observe any moving objects or things around you. Which energy do you think they possess when they are in motion? Explain your answer.

From your discussion in activity above, you should have observed that the trolley starts to move once given a slight push. It possess energy as it moves. The energy which is possessed by a moving object due to its speed is called **kinetic energy** (KE).

In other words we can define kinetic **energy as energy by virtue of motion**.

Examples of objects that posses KE include moving air, rotating windmills, falling water, rotating turbines and a moving stone. In general, any moving body possesses energy called kinetic energy.

The kinetic energy of a moving body is given by:

$$\text{Kinetic energy} = \frac{1}{2}mv^2, \text{ where } m \text{ and } v \text{ are the mass and velocity of the body respectively.}$$

Example 5.12

A body of mass 400 g falls freely from a tower and reaches the ground after 4 s. Calculate the kinetic energy of the mass as it hits the ground. (Take $g = 10 \text{ m/s}^2$)

Solution

The final velocity of the body as it hits the ground given by the equation of motion,

$$\begin{aligned}v &= u + at = u + gt = 0 + 10 \times 4 \\ &= 40 \text{ m/s}\end{aligned}$$

$$\begin{aligned}\text{K.E} &= \frac{1}{2}mv^2 \text{ (as the body hits the ground)} \\ &= \frac{1}{2} \times 0.400 \times 40^2 = 320 \text{ J}\end{aligned}$$

Example 5.13

A car of mass 1 000 kg travelling at 36 km/h is brought to rest by applying brakes. Calculate the distance travelled by the car before coming to rest, if the frictional force between the wheels and the road is 2 000 N.

Solution

$$\begin{aligned}V &= 36 \text{ km/h to m/s} \\ &= 36 \times \frac{1\,000}{60 \times 60} \text{ m/s} \\ &= 10 \text{ m/s}\end{aligned}$$

$$\text{K.E} = \text{work done against friction}$$

$$\frac{1}{2}mv^2 = F \times d$$

$$\Rightarrow \frac{1}{2} \times 1000 \times 10^2 = 2\,000 \times d$$

$$\Rightarrow 50\,000 = 2\,000 d$$

$$\therefore d = \frac{50\,000}{2\,000} = 25 \text{ m}$$

The stopping distance is 25 m.

5.5 Work and energy relationship

When work is done a transfer of energy always occurs. For example carrying a box up the stairs/lifting something heavy from the ground, you transfer energy to the box which is stored as gravitational energy. Therefore its energy increases.

Doing work is a way of transferring energy from one object to another. Just as power is the rate at which work is done when energy is transferred the power involved can be calculated by dividing the energy transferred by time needed for the transfer to occur.

$$\text{Power (in watts)} = \frac{\text{Energy transferred (in joules)}}{\text{time (in seconds)}}$$

$$P = \frac{E}{t} \text{ or } \text{Energy} = pt$$

For example, when the light bulb is connected to an electric circuit, energy is transferred from the circuit to the light bulb filament. The filament converts the electrical energy supplied to the light bulb into heat and light.

The power used by the bulb is the amount of electrical energy transferred to the light bulb each second.

Exercise 5.5

1. Define the term energy.
2. State and explain briefly six forms of energy.
3. Differentiate between:
 - (a) Potential energy and kinetic energy.
 - (b) Gravitational potential energy and elastic potential energy.
4. A brick of mass 0.5 kg is lifted through a distance of 100 m to the top of a building. Calculate the potential energy attained by the brick.

5. Explain what is meant by gravitational potential energy.
6. A force of 8.5 N stretches a certain spring by 6 cm. How much work is done in stretching the spring by 10 cm.
7. A body is acted on by a varying force, F over a distance of 7 cm as shown in Fig. 5.12.

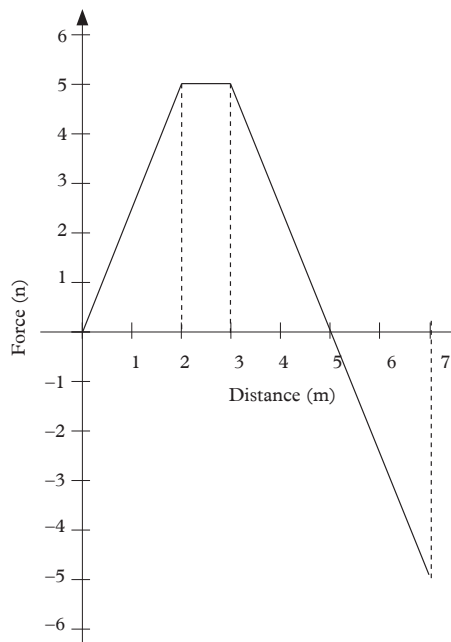

Fig. 5.12

Calculate the total work done by the force.

8. An object of mass 3.5 kg is released from a height of 7.0 m above the ground.
 - (a) Calculate the gravitational potential energy of the object release.
 - (b) Calculate the velocity of the object just before it strikes the ground.
What assumption have you made in your calculation?

5.6 Sources of energy

Activity 5.18

To find out sources of energy

(Working in groups)

Materials: Internet, reference books, a stream of water or a water tap

Steps

1. Tell your group members the meaning of the terms 'source' and 'energy source'.

2. Now, think of plants, animals, vehicles and so on. Where do you think their energy comes from? What of electricity used in your school and at home, where does it come from?
3. Compare and discuss your findings in step 1 and 2 with other groups in your class.
4. What is the meaning of primary sources of energy?
5. What is the meaning of secondary sources of energy?
6. Conduct a research from the Internet and reference books on primary and secondary sources of energy.
7. In your research find out:
 - (a) The types of primary and secondary sources of energy.
 - (b) The generation of energy from each source.
8. Let your secretary write down a summary of your discussion and present it to the whole class.
9. State and explain various types of primary and secondary sources of energy?

The word 'source' means the beginning of something e.g. the stream begins from the mountain or hills around your school.

Hey!!



Are you aware that cutting down trees will lead to the loss of our forests in our country and consequently the loss of water sources? Let us protect our water sources by planting more trees.

You should have also established that the energy source is a system which produces energy in a certain way. For instance, a hydroelectric station uses the motion of the water of the river to turn the turbines and thus producing electricity.

There are two kinds of energy sources;

1. Primary sources
2. Secondary sources

5.6.1 Primary sources of energy

From your research and discussion in activity 5.18, you should have established the following that Primary Sources are from sources which can be used directly as they occur in the natural environment. They include.

1. Flowing water
2. Nuclear
3. Sun
4. Wind
5. Geothermal (interior of the earth)
6. Fuels
7. Minerals
8. Biomass (living things and their waste materials)

1. Water

- (a) **Hydropower** - the flowing water from dams rotate turbines at the bottom of the dam which turn the generator resulting in generation of electricity. This water is kept behind a dam (reservoir) and released at a controlled rate downwards where it meets the turbines and turns them. An example is the falling water in the Fulla rapids on the River Nile in Nimule in South Sudan.
- (b) **Waves** - energy from water waves (generated by winds) is also used in generating electricity using sea wave converters. An example is pelamis wave energy converter, a technology that uses the motion of ocean surface waves to create electricity.

2. Nuclear energy

Nuclear energy is created through reactions that involve the splitting or merging of the atoms of nuclei together. The process of splitting of large atoms such as those of uranium into smaller atoms is called *fission*. *Fusion* on the other hand, is the combining of two smaller atoms such as hydrogen or helium to produce a heavier atom. All these reactions release heat which is turned into electricity in nuclear power plants (Fig 5.13). An atomic bomb derives its energy from these kinds of reactions.

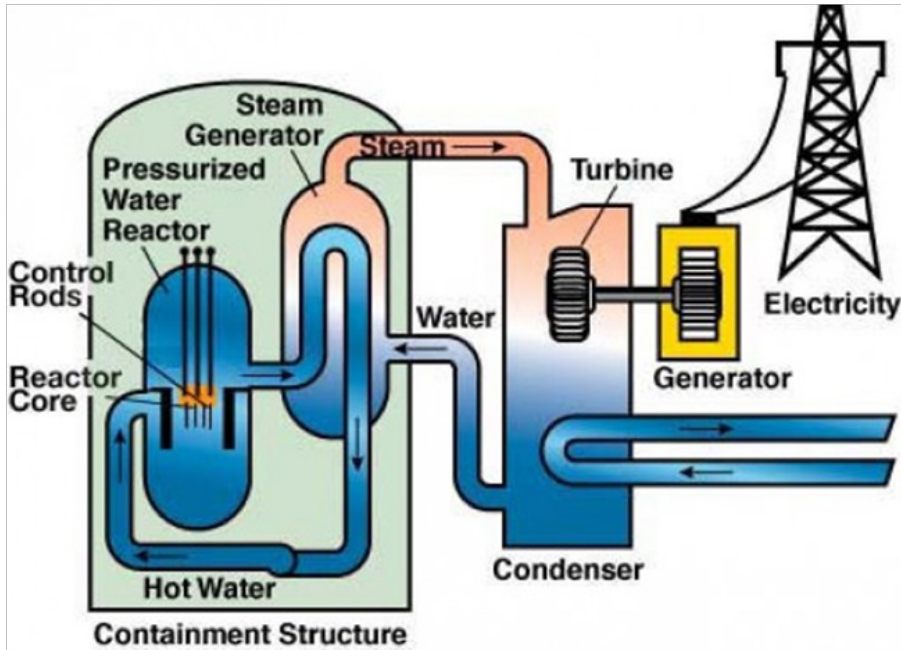

Fig 5.13: Nuclear plant

3. The sun

The sun is the biggest source of energy and has played an important role in shaping our life on earth since the dawn of time.

The sun gives off radiant energy in form of *electromagnetic waves*. The light energy (visible spectrum) part of the spectrum can be converted directly into electricity in a single process using the *photovoltaic (PV)* cell otherwise known as the *solar cell*.

The solar thermal energy is used for heating swimming pools, heating water for domestic use (solar heater) and heating of building. Solar thermal electricity generation is where the sun's rays are used to heat a fluid for the production of high pressure and high temperature steam. The steam is in turn converted into mechanical energy in a turbine to generate electricity.



(a) Solar panel



(b) Solar heater

Fig. 5.14: Solar panel and solar heater

4. Wind

Wind is caused by the sun heating the earth unevenly. The air is heated differently causing hotter air to expand rise, and the colder one to condense and sink. This results to the movement of air and hence formation of wind.

Modern wind turbines placed on the top of steel tubular towers harness the natural wind in our atmosphere and convert it into mechanical energy and then to electricity.

Wind mills (Fig. 5.15) are also be used to pump water from the underground and do some other work.



Fig 5.15: Wind mills

5. Geothermal energy

Geothermal gradient is the difference in temperature between the core (interior) of the earth (planet) and its surface brings about conduction of heat from the core to the surface. The earth's internal heat is generated from radioactive decay and continual heat loss from the earth's formation.

From hot springs, geothermal energy has been used for bathing to heal some diseases as in some cultures. Geothermal energy is also used to generate electricity at geothermal power stations where heat is used to heat water to get steam which in turn is used to turn the turbines to generate electricity.



Fig. 5.16 Geothermal power station

6. Thermal energy

Thermal energy is the internal energy in a system by virtue of its temperature. It is defined as the average translational kinetic energy possessed by free particles in a system of free particles in a thermodynamic equilibrium. It can also include the potential energy of a system's particle which may be an electron or an atom. Thermal (heat) energy is transferred of heat across the system boundaries. Thermal energy is important in our daily life, for example in warming the house, cooking, heating the water and drying the washed clothes.

7. Biogas

Activity 5.19

To conduct research on how to produce biogas

(Work in groups)

Materials: bio-digester, reference materials (including this book), internet

1. Using reference materials (including this book) or internet, research about how biogas is produced. Make notes and present your finding in class.
2. Make a trip to a farm with biogas plant and take turn to ask about working of biodigester.
3. Write a report explaining how a biodigester works?
4. Hold a group discussion and discuss about biogas as a source of energy.

Biomass is the total mass of organic matter in plant or animal. It is used to generate energy e.g. through burning to give heat energy.

When bacteria acts on biomass, a gas called biogas is produced which is flammable hence is used as fuel to produce heat. It is a mixture of 65% methane and 35% carbondioxide.

A **biogas plant** or digester collects and directs the gas through pipes to the kitchen for cooking in a house or to a generator where electricity is produced.

Fig. 5.17 shows a biogas plant.

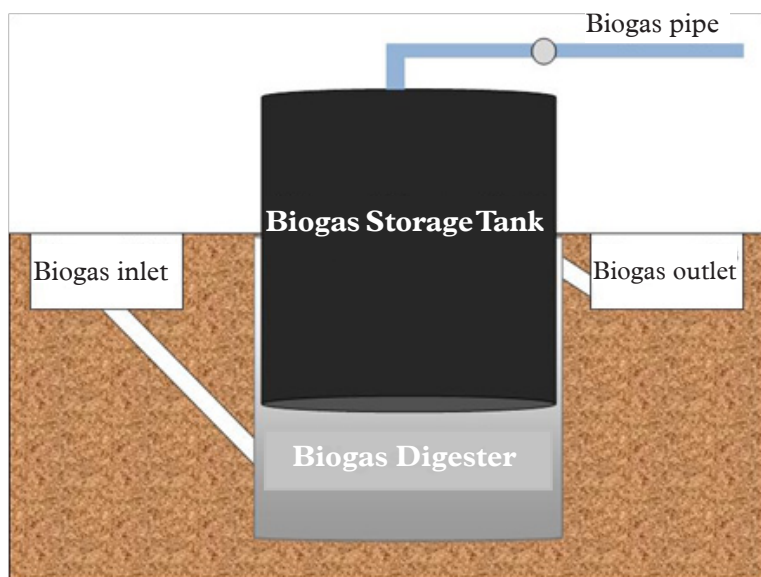

Fig. 5.17: Biogas plant

8. Fuels

Fuels are substances which produce heat when burnt in the presence of oxygen. They include kerosene, diesel, biogas, are sources of energy in homes, industries. In the process of combustion, the chemical energy in the fuel is converted into heat energy that is converted to other forms as desired.

9. Chemical energy

Chemical energy is stored in the chemical bonds of atoms and molecules. It can only be seen when it is released in a chemical reaction. When chemical energy is released, from a substance, the substance is entirely changed into an entirely different substance.

Some substances that store and release chemical energy are;

- (i) Electrolytes – the chemical reactions in an electrolyte in the batteries produce electricity.
- (ii) Petroleum – petroleum is made of molecules containing carbon and hydrogen. In vapour form, its natural gas and in liquid form, it is crude oil. Energy from petroleum is used to drive vehicles and to produce electricity. Examples include jet fuel, gasoline and others.
- (iii) Wood – dry wood acts as a store of chemical energy. This chemical energy is released when wood burns and it's converted into heat and light energy.

- (iv) Food – the chemical energy in food is released while the food is being digested. As the bonds between the atoms of the food break, new substances are created and chemical energy is given out.

Warning



Subjecting a battery to misuse or conditions for which it was not made for can result into battery failure or uncontrolled dangerous conditions which include explosion, fire and the emission of toxic fumes. Keep batteries well out of reach of children.

10. Light energy

The potential of light to perform work is called light energy. It is formed through chemical radiation and mechanical means. It is a form of energy produced by hot bodies and travels in a straight line. It's the only form of energy that we can see directly (visible light). It can be converted like sunlight energy is used during photosynthesis by plants to create chemical energy. UV lights are often used by forensic scientists to see details that are not seen by unaided eyes.

5.6.2 Secondary sources of energy

Secondary sources are energy sources that are generated from primary sources. For instance, electricity is a secondary source because it is generated for example from solar energy using solar panels or from flowing water using the turbines to generate hydroelectricity.

Other secondary sources of energy include; petroleum products, manufactured solid fuels, gases, heat and bio fuel.

5.7 Renewable and non renewable sources of energy

Activity 5.20

To distinguish between renewable and non-renewable sources of energy

(Work in pairs)

Materials: matchbox, reference books

Steps

1. Take one matchstick from the matchbox and light it.
2. Leave it to burn for a few seconds and then put it off.
3. Use the same matchstick and try to lit it again. Observe and explain what happens.
4. From the knowledge of sources of energy, what do you think renewable and non-renewable sources of energy are?

5. Discuss your observations in steps 2 and 3 with your deskmate.
6. Now, conduct a research from internet and reference book on renewable and non-renewable energy source.
7. Compare and discuss your findings with other groups in your class.

Hey!!! Be safe



Always be careful with fire. It can cause massive damage which can result to loss of properties and lives.

There are energy sources that cannot be used again once used to generate energy. They are called **non renewable sources** while those that can be used again without exhausting them are called **renewable resources**.

(a) Renewable energy sources

A renewable energy source is an energy source which can't be depleted/exhausted. They exist infinitely i.e. never run out. They are renewed by natural processes. Examples include;

- (i) Sun (ii) Wind (iii) Geothermal (iv) Biomass

However, some like trees they can also be depleted, like trees and animals if used too much more than the natural process can renew them. So it's advisable to take precaution while using them, that is, they should be conserved.

By doing so it will lead to access to affordable and reliable energy while increasing the share of renewable energy in our country. Hence contributing to affordable, reliable sustainable and modern energy for all. Achieving sustainable development goals (SDGs) by 2030 is a drive that countries across the world are working towards together. Gaining more of our energy from renewable sources is an important part of the strategy.

(b) Non-renewable energy sources

These are sources which can be depleted because they exist in fixed quantities. So they will run out one day. Examples are coal, crude oil, natural gas, and uranium.

Fossil fuels like coal, crude oil, natural gas are mainly made up of carbon. They are usually found in one location because they are made through the same process and material. Millions of years ago dead sea organisms, plants, and animals settled on the ocean floor and in porous rocks. With time, sand, sediments and impermeable rock settle on the dead organic matter, as the matter continues to decay forming coal, oil and natural gas. Earth movements and rock shifts create spaces that force these energy sources to collect at well-defined areas. With the help of technology, engineers are able to drill down into the sea bed to mine these sources and harness the energy stored in them.

5.8 Environmental effects of the use of energy sources

Activity 5.21

To investigate the environmental effects of the use of energy sources

(Work in groups)

Materials: reference books, Internet

Steps

1. Conduct research from the Internet and reference books on environmental effects of the use of energy sources.
2. In your research, identify the effects and suggest the measure to be taken to ensure safe use of those resources.
3. Record down your findings from your discussion and report them in a class discussion.

In Activity 5.24, you should have learnt that, there is no such thing as a completely “clean” energy source. All energy sources have at least an effect to the environment. Some energy sources have a greater impact than others. Energy is mostly lost into the environment in form of *heat* and *sound*.

The following are some of the effects of use of the energy sources to the environment:

- air and water pollution
- climate change and global warming.
- deforestation
- land degradation

(a) Air and water pollution

Fossil fuels e.g petroleum, diesel are used in factories. Very harmful by-products may be released to the atmosphere or water bodies. Carbon monoxides, sulphur dioxide and carbon dioxide may be released to the atmosphere causing air pollution that may harm living things that depend on air. When human beings inhale some of the polluted air, they can develop respiratory diseases. The wastes disposed to the water bodies can cause death of living things in the water. It also make the water unsafe for human consumption.

Factories and industries operators are encouraged to use bio-fuels which are less harmful to the environment. Most factories are trying to clean up the waste so as to reduce the environmental pollution.

(b) Climate change and global warming

Most energy sources e.g fossil fuels, coal etc, when used as sources of energy, produce wastes such as carbon dioxide, sulphur dioxide and mercury which are

the greenhouse gases. The accumulation of these gases in the atmosphere make the temperatures to be higher than the normal. This is referred to as *global warming*. Sometimes, these gases interfere with the climate causing very high temperature in the atmosphere, acidified rains, frequent droughts, floods etc. This results to *climate change*.

The greenhouse gases e.g. excess carbon dioxide, sulphur dioxide etc destroy the ozone layer exposing living things to dangerous emissions from the sun e.g. UV rays.

Release of these harmful gases into the atmosphere is a global problem and very many environmental agencies are encouraging on the proper disposal of these wastes.

United Nations Conference on Environment and Development (UNICED) lead Nations to sign a joint treaties to pursue of economic development in ways that would protect the earth's environment and non renewable resources but it is still a problem up to now.

(c) Deforestation

Using firewood and charcoal in most African countries lead to loss of biodiversity and erosion due to loss of forest cover. These may lead to deforestation i.e. *the reduction of forest cover*. Of great concern is that Africa is losing forest twice as fast as the rest of the world.

Human beings are encouraged to use green energy that is renewable and have less effect to the environment.

With your help we can support projects that help to train and educate forest communities so that they can use forests in a sustainable manner and protect their livelihoods for years.

(d) Land degradation

Land degradation is the process in which the value of bio-physical environment is affected by human – induced activity on the land. It is caused by over-cutting of vegetation e.g. forest, and woodland, for firewood and disposing factory wastes to the soil that may contaminate the soil. Use of non-biodegradable sources of energy is encouraged.

Saving our energy



Let's adopt the use of biogas in cooking, energy saving stoves and reduce the use of firewood to the possible level and amount of smoke generated reducing the impact of indoor air pollution. This will reduce environmental impacts.

Exercise 5.6

1. Differentiate between energy and power.
2. In groups of two, identify any three primary sources of energy and hold a discussion on their:
 - (a) definition and origin.
 - (b) importance to us and our country.
3. Choose any renewable energy resource. Brainstorm on two to three jobs opportunities available in that field.
4. Distinguish between the terms renewable resource and non-renewable resources.
5. Give one example of a body with potential energy due to its state.

5.9 Energy transformations

Activity 5.20

To investigate energy transformation

(Work in groups)

Materials: an electric heater, radio, water in a basin.

Steps

1. Place the electric heater in the basin with water and connect it to the socket.
2. Put on the switch. Observe and explain what happens after a couple of minutes. Suggest the types of energy involved in this case.
3. Now, disconnect the heater and connect the radio to the socket.
4. Turn the radio on and suggest the types of energy involved.
5. Repeat the activity by connecting wires, battery, switch and bulb. Observe and explain what happens when you make simple circuit and the switch is closed.
6. What is the meaning of energy transformation? Give five examples of energy transformation?
7. What is the name given to devices such as the radio, heater, battery, bulb etc. that converts energy from one form to another?
8. Discuss with your group members other forms of energy transformation and show with diagrams how energy is transformed from one form to another on the chalkboard.

Hey!!! Be safe



Don't touch water while an electrical heater is on, you may get an electrical shock.

From your discussion, you should have observed that the water in the basin boils. Electrical energy has been converted to heat energy which boils the water. When the radio was connect to the socket and turned on, electrical energy is converted to sound energy.

In step 5, when the wires are connected, the bulb is seen to give off light when you close the switch. This is because chemical energy in the battery has been converted to electrical energy which is then changed to light energy in the bulb and some part to heat energy.

Therefore, energy in many of its forms may be used in its natural process or to provide some services to society such as heating, refrigeration, or performing mechanical work to operate machines. This is possible because energy can be changed from one form to another. This process of changing of energy from one form to another is called **energy transformation**. A device that converts energy from one form to another is known as a **transducer**.

Fig 5.18 is a chart that shows some examples of energy transformation in our day to day activities.

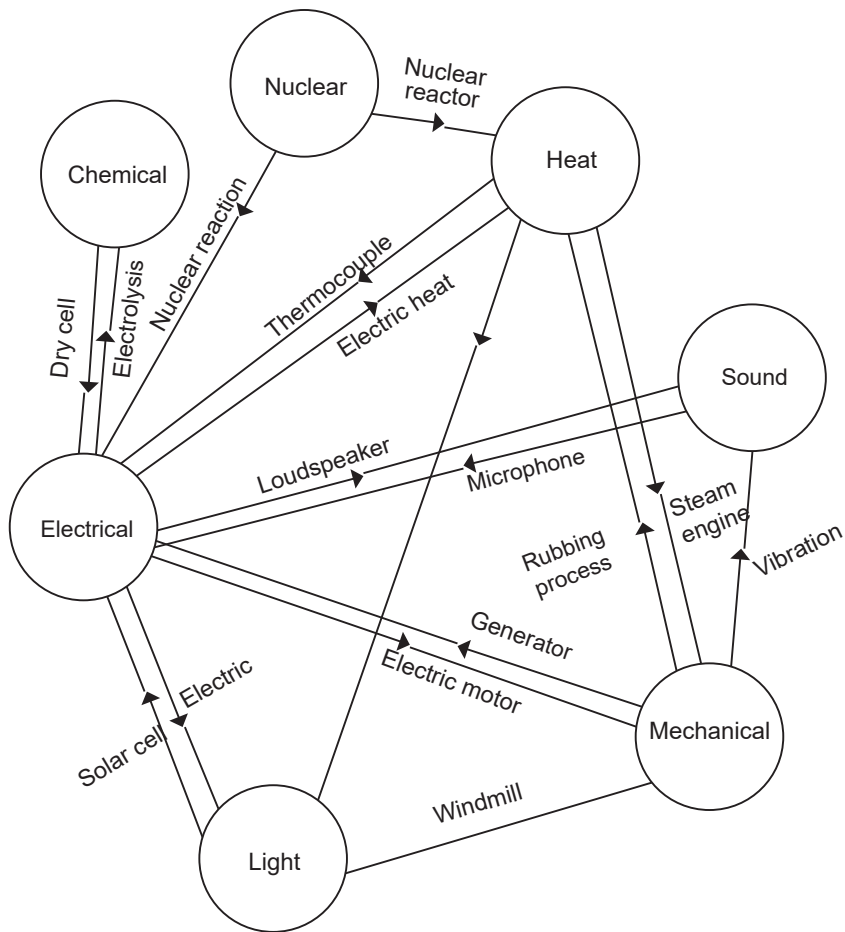

Fig. 5.18: A flow chart of energy transformation

Let us consider a few examples of energy transformation:

1. Hammering a nail

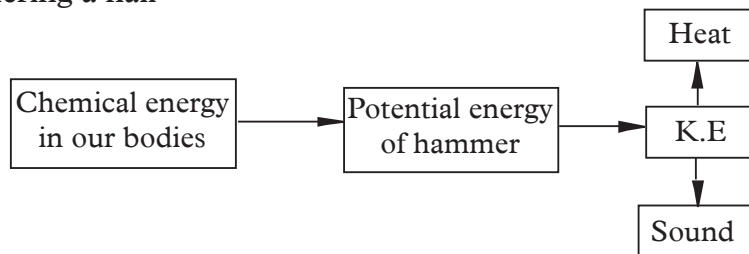

Fig. 5.19: Energy transportation

2. Lighting a bulb using a battery

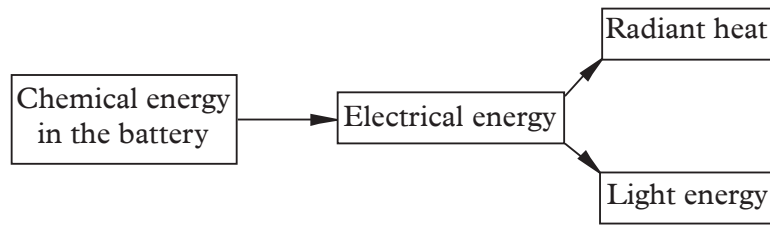

Fig. 5.20: Energy transformation

3. Hydroelectric power

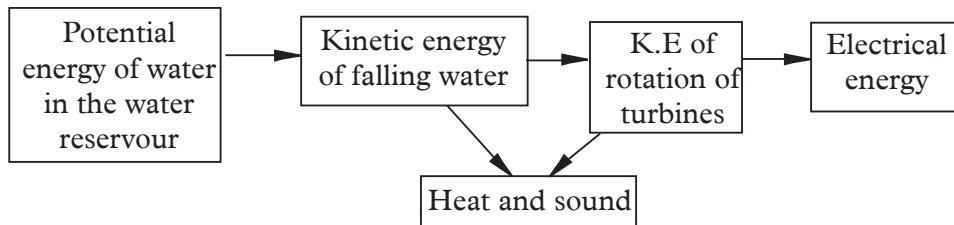

Fig. 5.20: Potential energy and its transformation

Other examples of energy transformers.

Wind turbines use wind energy to transform it into electricity.

Energy from **food** (chemical energy) can be transformed in energy to play and run.

A **solar cell/ panel** convert radiant energy of sunlight to electrical energy that can be used to give off lightning a bulb or to power a computer

The **sun** gives the grass thermal energy which helps it to grow by transforming the energy into chemical energy using photosynthesis. Animals eat grass and help them to grow and have power to run.

A **microphone** changes electric energy to sound energy and so on.

One other example of energy transformations occurs when **lightning strike**. If it hits a tree, it's electrical energy will be changed to heat and thermal energy. The tree will become hot and can even burn as a result of electric discharge, it can split and the leaves dry.

Exercise 5.7

1. Table 5.2 shows how energy is converted from form A to form B and the devices concerned. Complete the table.

Form A	Form B	Device
Electrical	Sound	Loudspeakers
Electrical	Kinetic	–
–	Electrical	Photocell
Sound	Electrical	–
–	Electrical	Thermocouple
–	–	Heater

Table 5.2: Forms of energy

2. Describe the energy changes that occurs in the following processes.
 - (a) When you lift a brick to a certain height.
 - (b) When you lift a brick and let it slide down a rough slope until it reaches the surface of the slope.
3. Describe the forms of energy shown in Fig 5.21.



Fig. 5.21: Forms of energy

4. Name the changes in energy that take place when a torch is switched on.
5. Name the energy changes that take place when lighting a match box.

5.10 Law of conservation of energy

Activity 5.23

To demonstrate the law of conservation of energy

(Work in pairs)

Materials: a ball

Steps

1. Hold a football at a height of 1 m above the ground. What type of energy does the ball possess at that position?
2. Release the ball to start falling freely to the ground. What type of energies does the ball possess while falling?
3. What type of energy does the ball possess while just about to touch the ground.
4. Ignoring air resistance, compare the amount of energy possessed by the ball in step 1 and 3. What can you conclude?

When the ball was stationary at a point 1 m above the ground in Activity 5.26, it possessed P.E. only. When released the P.E. started being converted to K.E. hence the ball dropped. When it was just about to touch the ground, all the P.E. had been converted to K.E. hence by ignoring air resistance,

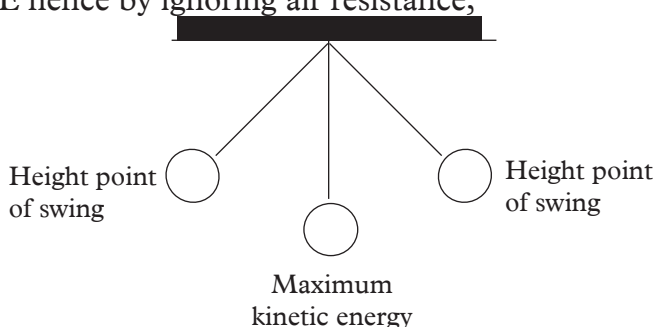

Fig. 5.22:

Initial P.E = final K.E

We say that energy has been conserved.

This is summarised in the **law of conservation of energy**.

The law of conservation of energy states that energy cannot be created or destroyed but is simply converted from one form into another. Or in other words we can state it that in a closed system the total amount of energy is conserved.

Energy can be inter-converted among many forms, mechanical, chemical, nuclear, electric, and others but the total amount of it remains constant.

For instance, in boiling water using a kettle, electrical energy drawn from the power source flows into the heating element of the kettle. As the current flows

through the element, the element rapidly heats up, so the electrical energy is converted to heat energy that is passed to the cold water surrounding it. After a couple of minutes, the water boils and (if the power source remains in the water) it starts to turn into steam. Most of the electrical energy supplied into the kettle is converted to heat energy in the water though some is used to provide latent heat of evaporation (the heat needed to turn a liquid into a gas without a change in temperature).

If you add up the total energy supplied by the power source and the total energy gained by the water, you should find they are almost the same. The minor difference would be due to energy loss in other forms.

Why aren't they exactly equal?

It's simply because we don't have a closed system. Some of the energy from the power source is converted to sound and wasted (kettles can be quite noisy). The kettles also give off some heat to their surroundings so that's also wasted energy.

Another example is a flying ball, that hits a window pane in a house, shattering the glass. The energy from the ball was transferred to the glass making it shatter into pieces and fly in various directions.

5.11 The law of conservation of mechanical energy

Activity 5.24

To verify the law of conservation of mechanical energy

(Work in pairs)

Materials: A smooth metallic hemispherical bowl, a ball bearing

Steps

1. Place the hemispherical bowl on the bench in a stable position. Mark at point A on the inside surface of the bowl at point A on the inside surface of the bowl
2. Place the ball bearing at point A and release it to slide downwards freely along the inside surface of the bowl as shown in Fig. 5.22.

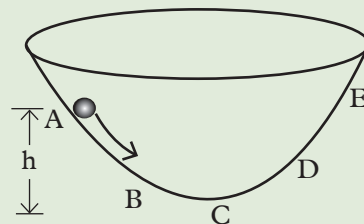

Fig. 5.22: A ball bearing sliding oscillating in a bowl

3. Mark point E where the ball rises to on the opposite side in the bowl.

4. Compare the vertical height of points A and E. What do you notice about the heights?
5. Repeat the activity with point A at a lower vertical height.
6. What type of energy does the ball bearings possess at points A, B, C, D and E.
7. Compare and comment on the total amount of energy possessed by the ball bearing at points A, B, C, D and E.
8. Make a conclusion based on your observation in step 7.

You should have learnt that the **law of conservation of mechanical energy** states that

The total mechanical energy (sum of potential energy and kinetic energy) in a closed system will remain constant/same.

A closed system is one where there are no external dissipative forces (like friction, air resistance) which would bring about loss of energy.

The sum of potential energy and kinetic energy anywhere during the motion must be equal to the sum of potential energy and kinetic energy anywhere else in the motion.

To demonstrate the law of conservation of mechanical energy

(a) A swinging pendulum

Activity 5.28

To demonstrate the law of conservation of M.E using a swinging pendulum

(Work in pairs)

Materials: a bob, string

Steps

1. Tie a string to the bob and fix it to a rigid object. (See Fig. 6.16).
2. Pull the bob to the right or left side at an angle and then release it. Observe the movement of the bob.
3. Draw a diagram for the motion of the pendulum and discuss with your class the energy changes at various points e.g. A, B, C, D and E shown in Fig. 5.24.

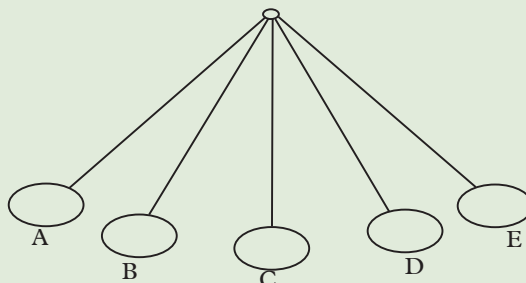

Fig. 5.24: A swinging pendulum

4. Explain the energy changes at points A, B, C, D

From the above activity, you should have noticed that the bob will attain a maximum potential energy due to its height above the ground at point A she have minimum kinetic energy because it is at rest.

When it swings after letting it go, it will start loosing potential energy as it gain kinetic energy at point B because of its motion. As it passes through the lowest point point C, its potential energy is minimum kinetic energy will be maximum. Because of its kinetic energy, it swings up to the other side and now its kinetic energy starts decreases as, potential energy increases at point D until when it reaches the maximum point E where it stops moving momentarily. At that point, it has maximum potential energy but minimum kinetic energy.

At all positions, the total mechanical energy is constant (conserved). That is kinetic energy + potential energy = constant. Therefore, mechanical energy has been conserved.

(b) A body thrown upwards

Activity 5.26

To demonstrate the law of conservation of M.E using a ball thrown upwards

(Work individually)

Materials: tennis ball

Steps

1. Throw a tennis ball upwards. Observe and describe the movement of the ball up to the maximum (highest) point.
2. Now, drop the ball from a high point e.g from top of the building or a cliff (see Fig 5.25).
3. Sketch its motion on a paper at three different intervals, starting from the lowest when thrown upwards or from highest when dropped from a cliff.
4. Explain why the ball falls back to the ground after thrown upwards.
5. Indicate the forms of energy at each stage.
6. Discuss your observations and drawing with your colleagues in class.

In your discussion, you should have learnt that when a body (e.g. a ball) is thrown up vertically, it has maximum speed, (maximum kinetic energy) at the starting point.

The ball moves up with a reducing speed because of the force of gravity acting on it downwards until it reaches the maximum point/ height where it stops moving momentarily and it falls back.

At maximum height, it has a maximum potential energy and minimum kinetic energy because the body is not moving. So the kinetic energy at the bottom is all turned into potential energy at the maximum point (Fig 5.25).

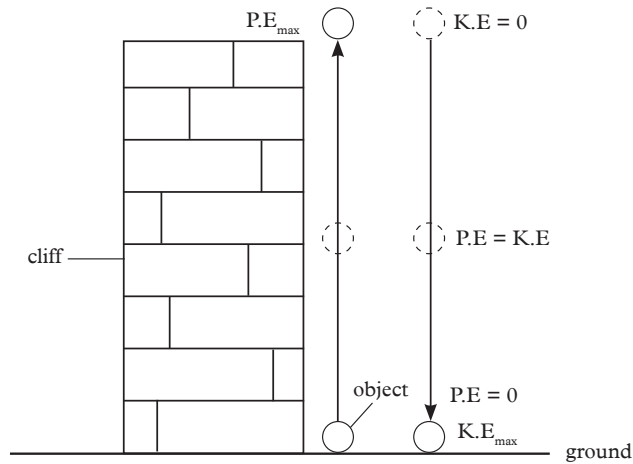

Fig. 5.25: Sketch of a ball thrown upwards

The ball is under free fall because it is only being acted upon by the force of gravity. Initially the ball has maximum potential energy and no kinetic energy. As it falls down, its potential energy keeps on reducing as its position above the ground reduces but its kinetic energy is increasing because it speeds up as it falls downwards.

The kinetic energy at the ground level is equal to the potential energy at the top of the wall. Hence mechanical energy is conserved.

Exercise 5.8

1. A pendulum bob swings as shown in the diagram. Fig 5.26

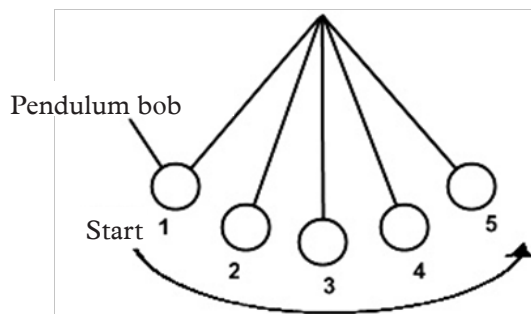

Fig 5.25: A pendulum swinging

At which position (s) is:

- (a) the kinetic energy of the pendulum bob least.
- (b) the potential energy of the pendulum bob most.

- (c) the kinetic energy of the pendulum bob the most.
 - (d) the potential energy of the pendulum bob the least.
2. State the following laws:
 - (a) law of conservation of energy
 - (b) law of conservation of mechanical energy.
 3. Describe how mechanical energy is conserved.

5.12 Ways of conserving energy

Activity 5.27

To do research about conservation of energy and identify ways of conserving energy

(Work in groups)

Materials: internet, reference book (including this book)

1. What is the meaning of the word conservation of energy?
2. Conduct a research from Internet and reference books on ways of conserving energy.
3. In your research, identify different ways of conserving energy and find out what energy efficiency is.
4. Discuss your finding with other pairs in class and give a report of your findings to the whole class.

From your research and discussion you should have established that energy conservation is the act of saving energy by reducing the length of use. In other words, to conserve energy, you need to cut back on your usage.

For example, driving your car fewer miles per week, turning your thermostat down a degree or two in the winter time and unplugging your computer or home appliance when they are not in use. All these ways reduce the amount of energy you use by doing without or using less fuel or electricity. It can help reduce the monthly heating and electricity bills and save money at the gas pump. You also reduce the demand of fuels like coal, oil, and natural gas. Less burning of fuels means lower emissions of carbon dioxide, the primary contributor of to global warming and other pollutants.

Other examples include:

- (i) Clean or replace air filters of cars as recommended. Energy is lost when air conditioners and hot air furnaces have to work harder to draw air through dirty filters. So save money by replacing old air filters with new (standard) ones which will take less electricity.

- (ii) Select the most energy efficient models when you replace the old appliances. Look for the energy star label because the product saves energy and prevents pollution.
- (iii) Turn your refrigerator down. Refrigerators accounts for about 20% of the house hold electricity costs.
- (iv) Buy energy-efficient compact fluorescent bulbs for the lights you use most. Although they cost more, they save money in the long run because they only use a quarter the energy used by ordinary incandescent lamps and lasting 8-12 times longer.
- (v) Reduce the amount of waste you produce by buying minimally packaged goods, choosing reusable products over disposable ones, and recycling. Use 30% to 50% less paper products, 33% less glass and 90% less aluminum.
- (vi) People who live in colder areas should super insulate your walls and ceiling. It can save your the electricity of heating or fire wood costs.
- (vii) Plant shady trees and paint your house a light colour if you live in a hot place or paint them a dark colour if you live in cold conditions.

If we do not conserve energy, it will be exhausted and we will have nothing to use. Energy conservation is also important when in managing climate change. Currently erratic climates and climatic changes are the greatest threats that we are facing today. Hence it is important to conserve energy.

5.13 Energy efficiency

Energy efficiency is the act of saving energy but keeping the same level of service.

For example, if you turn off the lights when you are leaving a room, that's energy conservation, if you replace an efficient incandescent light bulb with a more efficient compact fluorescent bulb, you are practicing energy efficiency.

Energy efficiency uses advances in sciences and technology to provide services and products that require the use of less energy.

Exercise 5.9

1. (a) Demonstrate how mechanical energy is conserved.
(b) What is energy efficiency?
2. By identifying practical activities in our daily lives, discuss how you can conserve energy.

Project work 1

Energy saving charcoal burner

In most developing countries, wood is the most important source of energy mainly for cooking. The amount of wood consumed depends on the climate, culture and availability. Most people use open, three stone fireplaces for cooking. The fireplaces are often dirty, dangerous and inefficient. The smoke and soot settles on utensils, walls, ceiling and people. The smoke produced in fireplaces irritates people posing danger to health. The fireplaces have been found to be about 10-15% efficient.

In view of the above, energy saving stoves have been designed. Most of these stoves use charcoal. Charcoal is preferred to wood in urban areas because of its portability, convenience and cleanliness. In designing energy saving stoves, one should try to minimise energy losses to the surrounding. One of the many advantages of a charcoal stove, is that the rate of charcoal burning can be controlled.

Materials

Metal sheets and clay

Construction

Cut the metal sheet into a circular sheet (Fig. 5.27(a)). The radius AO will depend on the size of the stove required. Mark arc AB which represents the circumference of the *mouth* of the charcoal burner. Draw AO and OB. Draw arc CD. The radius OD will depend on the area of the base on which the charcoal is to rest. Cut the section ACDB.

Assembly

Fold the plate ACDB in a shape of a cone as shown in Fig. 5.27(b). Rivet the sides AC and BD together.

Repeat the procedure to construct the lower compartment. But this time make AC and DB shorter.

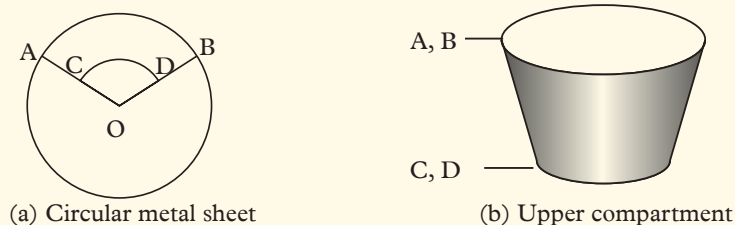

Fig. 5.27: Making the upper compartment of an energy saving charcoal burner

Bring the two compartment together and join them by riveting Fig. 5.28(a). Cut off a small section of the lower compartment and construct a gate. Mould clay in such a shape that it fits into the upper compartment. Make the air holes while the clay is still wet.

Allow the clay to dry. Construct the stands for holding the cooking pot. A complete stove should look like the one shown in Fig. 5.28(b).

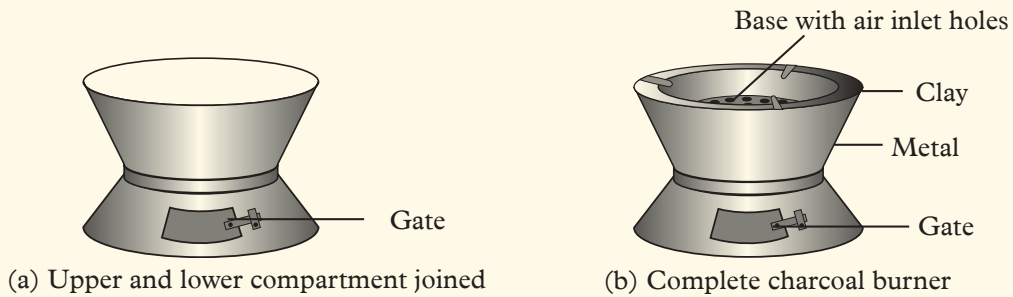

Fig. 5.29(a): Upper and lower compartments joined to make a complete charcoal burner

Larger stove can be made by cutting the sheet as shown in Fig. 5.29.

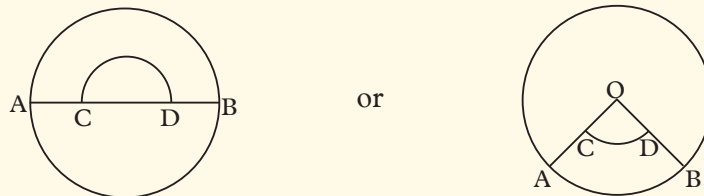

Fig. 5.29: Larger jikos

Project work 2

Solar heater

Solar energy can be trapped with the help of solar heater and utilized to heat water. The most common type of solar water heater incorporates a flat-plate solar collector and a storage tank. The tank is positioned above the collector. Water from the tank is circulated through the collector and back to the tank by means of convectional currents caused by the heated water.

Construction of a solar heater

Suggested materials

A 20 litre jerry can container, plastic pipes, cellophane paper, half open 20 litre jerry can, black paint or smoke soot and a wire mesh.

Assembly

Heat collector

Paint the plastic pipes black. Use a wire mesh and curve the plastic pipes as shown in Fig. 5.30. The size of the wire mesh should be able to fit into an open 20 litre jerry can container.

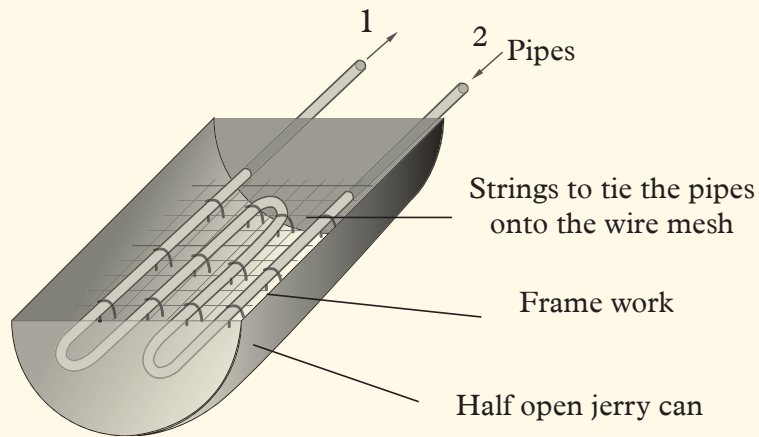

Fig. 5.30: Heat collector

Heat exchanger

Use another 20 litre jerry can (Fig. 5.31) and open at the top to allow the pipes to enter and then seal it using the same material and a hot object. The hot object will make the materials to fuse together. Make provisions for water to enter and leave the heat exchanger when required.

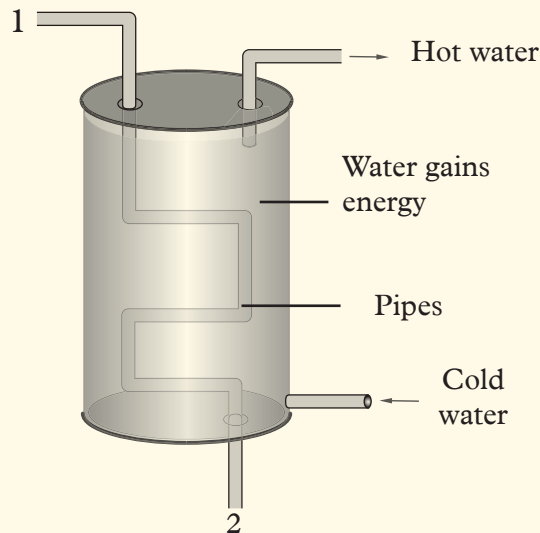

Fig. 5.31: Heat exchanger

Join pipe 1 of the heater collector to pipe 1 of the heat exchanger. Do the same with pipe 2. Make sure the collector is inclined at a certain angle to allow water from the heat exchanger to flow freely. (Fig. 5.32).

Cover the heat collector with a cellophane paper.

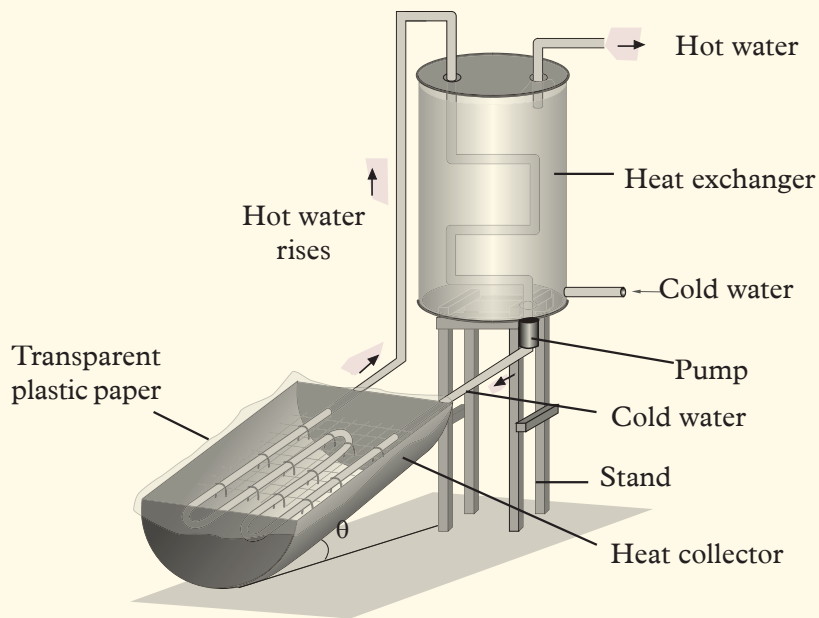

Fig 5.33: Solar heater

How to use

Fill the pipes of the heat collector with water and expose them to the sun. Allow water from a reservoir to fill the heat exchanger.

Topic summary

- **Work** is the product of force and distance moved in the direction of the force.
- A **joule** is the work done when a force of one newton acts on a body and makes it to move a distance of one metre in the direction of the force.
- When work is done on an object, energy is transferred. Work is said to be done if a force acts on a body and makes it move (get displaced) in the direction of the force
- **Energy** is the ability to do work.
- Moving objects have kinetic energy that depends on the mass of the body and the velocity.
- **Potential energy** is the energy possessed by a body due to its position. It depends on the objects height above the ground.
- The total amount of kinetic energy and potential energy in a system is the mechanical energy of the system. Mechanical energy = KE + PE.
- Falling, swinging, and projectile motion all involve transformations between kinetic and potential energy.

- According to the **law of conservation of energy**, energy cannot be created or destroyed but can only be converted from one form to another.
- Energy is converted changes from one form to another by transducers such as light bulbs, hair driers. For example, a hair drier converts electrical energy into thermal energy, kinetic energy and sound energy.
- Fuel is a substance which when burnt produces heat.

Topic Test 5

1. Define the term power and give its SI unit.
2. A motor raised a block of mass 72 kg through a vertical height of 2.5 m in 28 s. Calculate the:
 - (a) work done on the block.
 - (b) useful power supplied by the motor.
3. A person of mass 40 kg runs up a flight of 50 stairs each of height 20 cm in 5 s. Calculate:
 - (a) the work done.
 - (b) the average power of the person.
 - (c) explain why the energy the person uses to climb up is greater than the calculated work done.
4. A runner of mass 65 kg runs up a steep slope rising through a vertical height of 40 m in 65 s. Find the power that his muscles must develop in order to do so.
5. A fork-lift truck raises a 400 kg box through a height of 2.3 m. The case is then moved horizontally by the truck at 3.0 m/s onto the loading platform of a lorry.
 - (a) What minimum upward force should the truck exert on the box?
 - (b) How much P.E. is gained by the box?
 - (c) Calculate the K.E of the box while being moved horizontally.
 - (d) What happens to the K.E once the truck stops?
6. A stone falls vertically through a distance of 20 m. If the mass of the stone is 3.0 kg,
 - (a) Sketch a graph of work done by the gravity against distance.
 - (b) Find the power of the gravitational pull.

7. Mugisha climbs 16 m rope in 20 s. If his mass is 60 kg, find the average power he developed.
8. A car is doing work at a rate of $8.0 \times 10^4 \text{ W}$. Calculate the thrust of the wheels on the ground if the car moves with a constant velocity of 30 m/s.
9. Uwimbabazi took 55.0 s to climb a staircase to a height of 14.0 m. If her mass is 40 kg, find:
 - (a) How much force did she exert in getting to the that level?
 - (b) Her power?
10. In Fig. 5.33 three positions of a monkey swinging from a branch of a tree are shown.

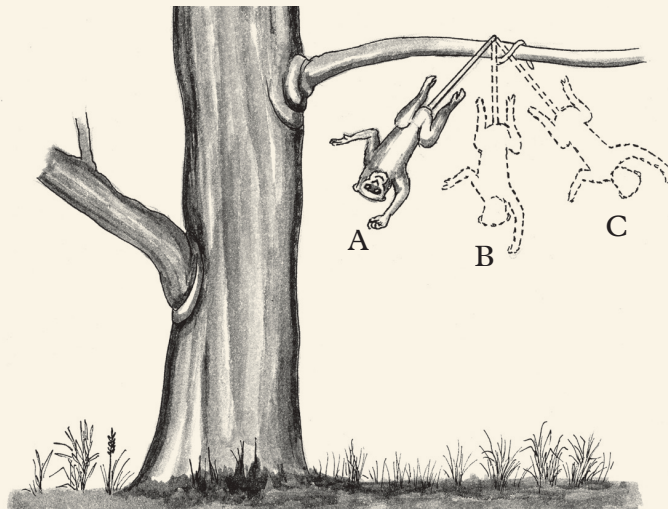

Fig. 5.33: A monkey swinging

- (a) What kind of energy does the monkey have at each position?
- (b) What happens to the energy when the monkey is midway between A and C?
- (c) In which positions does the monkey have the least energy? What name is given to this type of energy?
- (d) What type of energy would the monkey have if it stopped swinging but still hanging?

11. A device which converts one form of energy to another is called a *transducer*. Name one transducer in each of the cases energy transformation given below.

- (a) Heat to kinetic energy
- (b) Electrical to light
- (c) Sound to electrical
- (d) Potential energy to kinetic energy
- (e) Chemical to electrical

12. Discuss the energy transformations in Fig. 5.34.

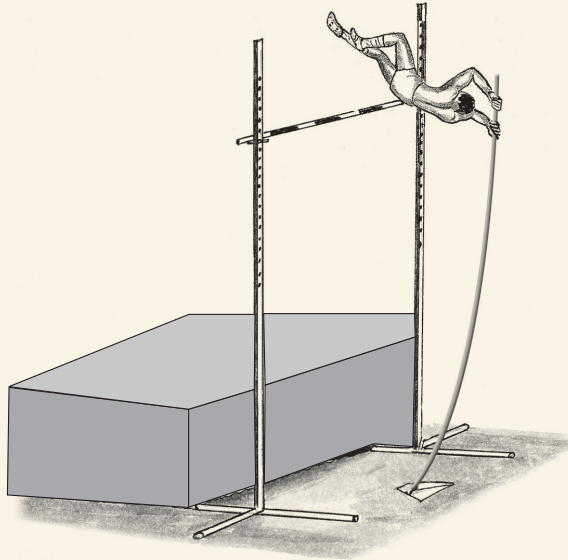

Fig. 5.34: A boy jumping

- 13.**
- (a) State the law of conservation of energy.
 - (b) Differentiate between renewable and non-renewable sources of energy. Give two examples of each.
 - (c) Explain the energy transformation in a hydroelectric power station.

Topics in the unit

Topic 6: Machines

Learning outcomes**Knowledge and Understanding**

- Define machines and explain the dynamics of objects

Skills

- Design and carry out tests on pulleys and simple pulleys of different velocity ratios may be assembled Predict what might happen.
- Observing carefully.
- Use appropriate measures.
- Collect and present results appropriate in writing or drawing.
- Derive and Calculate mechanical advantage, velocity ratio and efficiency of a given machine.
- Draw a labeled diagram to explain a lever.

Attitudes

- Appreciate use of machine to ease work.

Key inquiry questions

- Why do vehicles use low gears in steep places?
- Why are pulleys important in load lifting?
- Why does a cyclist get tired when cycling up-hill?
- How can we design machines to enable humans to move masses greater than the human mass?

Unit outline ▶▶▶

- Definition of simple machines.
- Examples of simple machine (lever, pulley, wedge and axle, inclined plane, screw).
- Working principal of simple machines.
- Machine work out and friction in the machine.
- Mechanical advantage and velocity ratio of a machine.
- Determination of output of simple machine (efficiency).
- Experiment to determine efficiency of simple machines.

Introduction

In everyday life, people perform various tasks in order to improve their standards of life, environment, quality of health, and understanding of natural phenomena in order to exploit and be in terms with them. Some of the tasks people do include; drawing of water from a well using a windless, construction of houses using timber, nail and harmer, loading and unloading of good into the ships for export, joining of timber and metal using screws, splitting of firewood using a wedge, digging a garden in preparation for planting, lifting heavy objects into tracks. The devices that help us to perform work easily are called **machines**.

Machines can either be simple or compound. In topic 3, we learnt about some of the applications of moment of a force. Most simple machines apply the same principle in making work easier. In this topic we are going to learn, understand and apply the principles behind simple machines.

6.1 Definition of simple machines**Activity 6.1****To find out the definition and importance of a machine**

(Work in groups)

Materials: closed soda bottle, a bottle opener**Steps**

1. Open a soda bottle with your hand. Is it easy to open the bottle using your hand?
2. Now try opening the same bottle using an opener. Is it easier to open the bottle using an opener? Which of the two tasks is easier and why?
3. Based on your observation in steps 1 and 2, define a simple machine.

In topic 3, we learnt about moments and how it is applied in machines. In the above experiment the bottle opener applies moments to open a soda. It is a simple machine. A **machine** is a mechanical device or a system of devices that is used to make work easier. For example in loading an oil drum onto a truck, it is easier to roll it up an inclined plane (Fig. 6.1(a)) than lifting it up onto the truck (Fig. 6.1(b)).

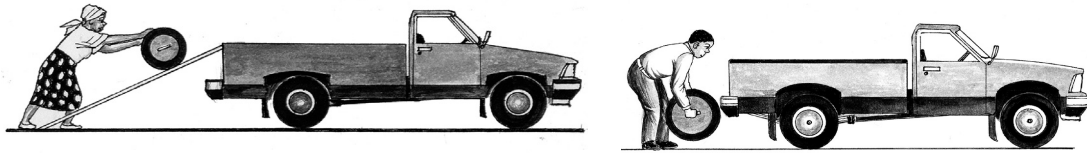

(a) Rolling up a drum into a truck

(b) Lifting up a drum into a truck

Fig. 6.1: Machines make our work easier

A machine may be defined as *any mechanical device that facilitates a force applied at one point to overcome another force at a different point in the system*. Examples of simple machines include lever, pulley, wedge, wheel and axle, inclined plane, and screws.

A **simple machine** is a machine that is made up of only one type of machine. Examples of simple machines are the screw, lever, inclined plane, pulley, wheel and axle and gears.

A **compound machine** is made up of more than one simple machines working together to perform a particular task with ease. An example of a compound machine is the car engine. The car engine consists of pulley, belts, gears, wheel and axle, pistons and other simple machines working together to bring about the movement of the car.

In **mechanical machines**, the force that is applied is called the **effort (E)** and the force the machine must overcome is called the **load (L)**. Note that both the load and effort are forces which act on the machine.

6.2 Mechanical advantage, velocity ratio and efficiency of machines

Activity 6.2

To investigate and determine mechanical advantage, velocity ratio and efficiency of machines

(Work in groups)

Materials: Internet, reference books, inclined plane

Instructions

1. In pairs conduct research from the Internet or reference books on the terms used to describe the ability of doing work easily by use of machines.
2. In your research, find out what is mechanical advantage? What is velocity ratio? What is efficiency of machine?
3. Modify the set-up using locally available materials such as stones and timbers to make an inclined plane. Draw the set-up.

4. Write a brief procedure on how to determine M.A, V.R, and efficiency of the inclined plane.
5. Write a report about your investigation and explain how the experiment can be improved.
6. Present your findings in a class discussion.

Mechanical advantage (M.A) of machines

Machines overcome large loads by applying a small effort i.e. the machines magnify the force applied.

Mechanical advantage is **the ratio of load to the effort**. It describes how the applied force compares with the load to be moved. A machine with a mechanical advantage (M.A) of 1 does not change the force applied on it. A machine with a M.A of 2 can double your force, so you have to apply only half the force needed.

$$\text{Mechanical advantage} = \frac{\text{force applied by the machine to do the work (Load)}}{\text{force applied to the machine by the operator (Effort)}}$$

$$\therefore \text{Mechanical advantage (M.A)} = \frac{\text{load (N)}}{\text{effort (N)}}$$

Since mechanical advantage is a ratio, it has no units.

Velocity ratio (V.R) of a machine

Velocity ratio of a machine is the *ratio of the velocity of the effort to the velocity of the load*.

$$\begin{aligned} \text{Velocity ratio (V.R)} &= \frac{\text{velocity of the effort}}{\text{velocity of the load}} \\ &= \frac{\frac{\text{displacement of effort}}{\text{time}}}{\frac{\text{displacement of load}}{\text{time}}} \end{aligned}$$

Since the effort and the load move at the same time,

$$\therefore \text{Velocity ratio (V.R)} = \frac{\text{displacement of effort}}{\text{displacement of load}} \text{ or (V.R)} = \frac{\text{effort distance}}{\text{load distance}}$$

Velocity ratio has no units

Efficiency of machines

For a perfect machine, the work done on the machine by the effort is equal to the work done by the machine on the load. However, there is no such a machine because some energy is wasted in overcoming friction and in moving the moveable

parts of the machine. Hence, more energy is put **into** the machine than what is **output** by it. Thus,

$$\text{Work input} = \text{Useful work done} + \text{Wasted work done}$$

To describe the actual performance of a machine we use the term **efficiency**. Efficiency tells us what percentage of the work put into a machine is returned as useful work.

The efficiency of a machine is defined as the ratio of its energy output to its energy input.

$$\text{Efficiency} = \frac{\text{useful energy output}}{\text{energy input}} \times 100\%$$

or

$$\begin{aligned} \text{efficiency} &= \frac{\text{useful work output}}{\text{work input}} \times 100\% = \frac{\text{load} \times \text{distance moved by load}}{\text{effort} \times \text{distance moved by effort}} \times 100\% \\ &= \frac{\text{load}}{\text{effort}} \times \frac{\text{distance load is moved}}{\text{distance moved by effort}} \times 100\% \\ &= \text{M.A} \times \frac{1}{\text{V.R}} \times 100\% \end{aligned}$$

$$\therefore \text{Efficiency} = \frac{\text{M.A}}{\text{V.R}} \times 100\%$$

Example 6.1

A machine whose velocity ratio is 8 is used to lift a load of 300 N. The effort required is 60 N.

- (a) What is the mechanical advantage of the machine?
- (b) Calculate the efficiency of the machine

Solution

$$\text{(a) Mechanical advantage} = \frac{\text{load}}{\text{effort}} = \frac{300 \text{ N}}{60 \text{ N}} = 5$$

$$\begin{aligned} \text{(b) Efficiency} &= \frac{\text{M.A}}{\text{V.R}} \times 100\% \\ &= \frac{5}{8} \times 100\% \\ &= 62.5\% \end{aligned}$$

Example 6.2

An effort of 250 N raises a load of 900 N through 5 m in a machine. If the effort moves through 25 m, find

- (a) the useful work done in raising the load
- (b) the work done by the effort
- (c) the efficiency of the machine

Solution

(a) Useful work done in raising the load
= load \times distance moved by load
= $(900 \times 5) = 4\,500$ J

(b) Work done by the effort
= effort \times distance moved by effort
= $250 \times 25 = 6\,250$ J

(c) Efficiency = $\frac{\text{work output}}{\text{work input}} \times 100\%$
= $\frac{4\,500 \text{ J}}{6\,250 \text{ J}} \times 100\%$
= 72%

Example 6.3

Calculate the efficiency of a machine if 8 000 J of work is done on the machine to lift a mass of 120 kg through a vertical height of 5 m.

Solution

Work done in lifting the load = $1\,200 \times 5$
= 6 000 J

Work input = 8 000 J

Efficiency = $\frac{\text{work output}}{\text{work input}} \times 100\%$
= $\frac{6\,000 \text{ J}}{8\,000 \text{ J}} \times 100\%$
= 75%

6.3 Types of simple machines

Activity 6.3

To identify types of simple machines

(Work in pairs)

Steps

1. Now, access the internet and reference books and conduct research on classification of simple machines.
2. Classify simple machines
3. Discuss your findings with other groups in your class.

Simple machines are classified into two groups i.e. **force multiplier** and **distance or speed multipliers**. Force multipliers are those that allow a small effort to move a large load e.g. levers. Distance or speed multipliers are those that allow a small movement of the effort to produce a large movement of the load e.g. fishing rod, bicycle gear etc. Let us consider some simple machines and show how they operate.

6.3.1 Levers

Activity 6.4

To demonstrate the working of levers

(Work in groups)

Materials: a nail, claw hammer, piece of cloth, a pair of scissors, groundnut, pliers.

Part 1

Steps

1. Drive a long iron nail into a piece of timber.
2. Try to remove the nail from the timber using your fingers. Is it easy to remove the nail using your finger?
3. Use a claw hammer instead of your fingers. Explain?
4. When using fingers and a claw hammer, which task did you apply more effort? Explain why.

Part 2

Steps

1. Cut piece of cloth into two pieces using your hands.
2. Use a pair of scissors instead of your hands. Between using your hands and using a pair of scissors, which task did you apply more effort?

Part 3

Steps

1. Crush a groundnut using your fingers. Are you able to crush it?
2. Now crush it using a nut cracker. Why is it easier and faster to crush a groundnut using a nut cracker than your hand.

Using the simple machine, the work becomes easier. These types of machines used in the above activity are called **levers**.

Levers are simple machines that apply the principle of moments. A lever consists of a rigid bar capable of rotating about a fixed point called the pivot. The effort arm is the perpendicular distance from pivot to the line of action of effort (See Fig. 6.2).

There are 3 **classes** of levers. The difference between these types depends on the position of the pivot (fulcrum) with respect to the load and the effort.

1. **First class.** The pivot is between the load and the effort. Examples (Fig. 6.2).

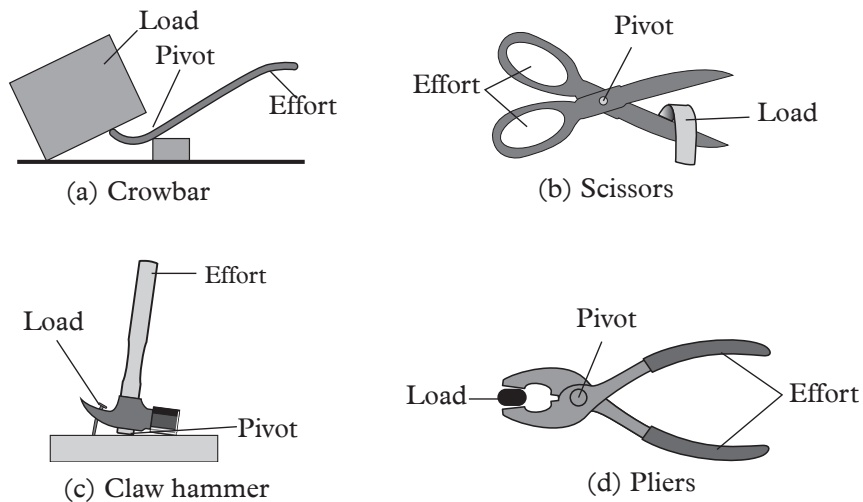

Fig. 6.2: Pivot between the load and the effort

2. **Second Class:** The load is between the effort and the pivot. Examples (Fig. 6.3).

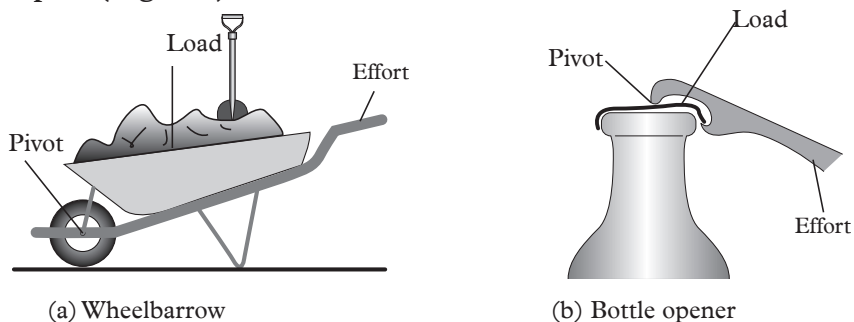

Fig. 6.3: Load between efforts and pivots

3. **Third class:** The effort is between the load and the pivot. Examples (Fig. 6.4).

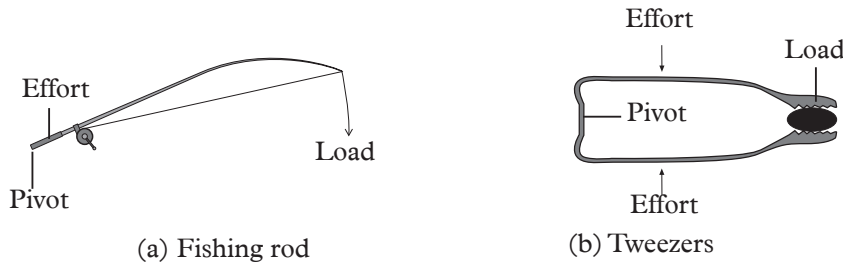

Fig. 6.4: Efforts between load and pivots

Mechanical advantage of levers

Consider a lever with the pivot between the load and the effort (Fig. 6.5).

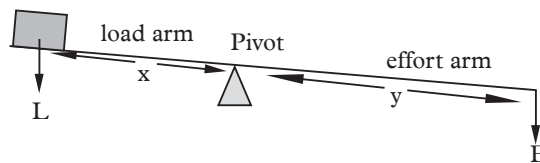

Fig. 6.5: Mechanical advantage for levers.

Taking moment about the pivot

$$\text{load} \times \text{load arm} = \text{effort} \times \text{effort arm}$$

$$\frac{\text{load}}{\text{effort}} = \frac{\text{effort arm}}{\text{load arm}}, \text{ But } \frac{\text{load}}{\text{effort}} = \text{mechanical advantage}$$

$$\text{Mechanical Advantage, M.A} = \frac{\text{effort arm}}{\text{load arm}} = \frac{y}{x}$$

This also applies to the other types of levers.

Since effort arm is usually greater than load arms, levers have mechanical advantage greater than 1.

Velocity ratio (V.R) levers

Consider three types of levers in which the load and the effort have moved a distance d_L and d_E respectively (Fig. 6.6).

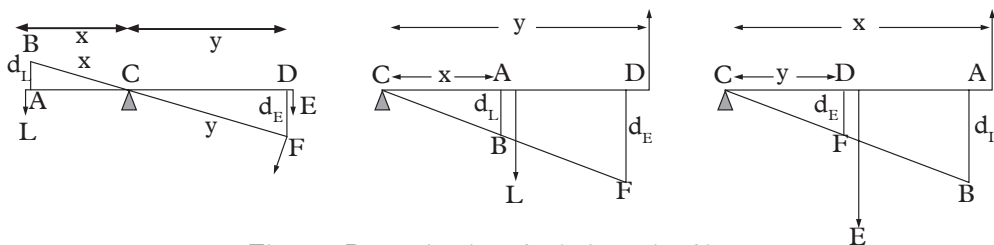

Fig. 6.6: Determination of velocity ratio of levers

Triangles ABC and DFC are similar triangles.

$$V.R = \frac{d_E}{d_L} = \frac{y}{x}$$

In Fig. 6.6(a) and (b), y is greater than x . The velocity ratio is therefore greater than 1. However in (c), y is less than x , and therefore the velocity ratio is less than 1. Cases (a) and (b) are examples of **force multipliers**. All force multipliers have M.A and V.R greater than 1. Case (c) is an example of **distance multiplier** in which both the velocity ratio and mechanical advantage are less than 1.

Example 6.4

A lever has a velocity ratio of 4. When an effort of 150 N is applied, a force of 450 N is lifted. Find: (a) mechanical advantage (b) efficiency of the lever.

Solution

(a) Mechanical advantage = $\frac{\text{load}}{\text{effort}} = \frac{450 \text{ N}}{150 \text{ N}} = 3.0$

(b) Efficiency = $\frac{M.A}{V.R} = \frac{3}{4} \times 100\%$
 $= 75\%$

Example 6.5

A worker uses a crow bar 2.0 m long to lift a rock weighing 650 N (Fig. 6.7).

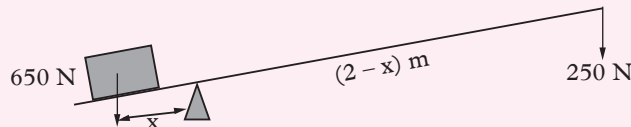

Fig. 6.7: Crow bar

- (a) Calculate the position of the pivot in order to apply an effort of 250 N.
 (b) Find the: (i) velocity ratio (ii) mechanical advantage and (iii) efficiency of the lever.
 (c) What assumptions have you made?

Solution

(a) Applying the principle of moments (b) (i) velocity ratio = $\frac{\text{effort distance}}{\text{load distance}}$
 $650x = 250(2-x)$
 $650x = 500 - 250x$
 $900x = 500$
 $x = 0.56 \text{ m from the end with } 650 \text{ N.}$
 $= \frac{1.44}{0.56}$
 $= 2.57$

(ii) mechanical advantage = $\frac{650}{250} = 2.6$

(iii) efficiency = $\frac{M.A}{V.R} \times 100\% = \frac{2.6}{2.6} \times 100\% = 100\%$

(c) We have assumed that there is no friction and that the crowbar has weight.

Exercise 6.1

1. A machine requires 6 000 J of energy to lift a mass of 55 kg through a vertical distance of 8 m. Calculate its efficiency.
2. A machine of efficiency 65% lifts a mass of 90 kg through a vertical distance of 3 m. Find the work required to operate the machine.
3. A machine used to lift a load to the top of a building under construction has a velocity ratio of 6. Calculate its efficiency if an effort of 1 200 N is required to raise a load of 6 000 N. Find the energy wasted when a load of 600 N is lifted through a distance of 3 m.
4. Define the following terms as applied to levers:
(a) mechanical advantage (b) velocity ratio
5. Find the velocity ratio of the levers shown in Fig. 6.8.

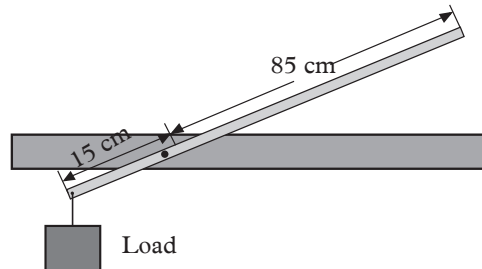

Fig. 6.8: Levers

6.3.2 Inclined plane

Activity 6.5

To determine the work done when pulling an object on a flat surface and on an inclined plane

(Work in groups)

Materials: piece of wood, a spring balance, tape measure, a trolley, a cardboard, reference books, Internet.

Steps

1. Attach a spring balance on the trolley. Place a piece of wood in the trolley.
2. Pull the piece of wooden from the ground vertically upwards using the spring balance. Record the force reading on the spring balance.

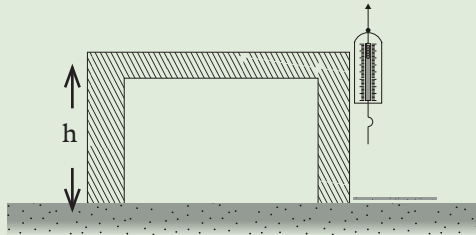

(a) A piece of wood moved vertically upwards through (h)

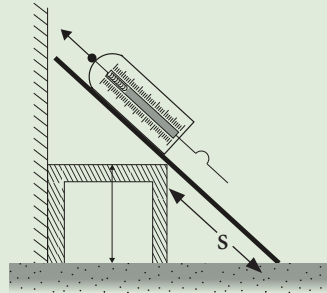

(b) Moving the load along the slope through s

Fig 6.9: Determination of work done

3. Using a tape measure, measure the height (h) of a table. Calculate the amount of work done when the load is lifted from the floor to the top of table (Fig. 6.9(a)).
4. Incline a wooden plank against the edge of the table.
5. Measure the force needed to pull the load (piece of wood in a trolley) up along inclined plane at a constant speed up to the top of the table (Fig. 6.9(c)).
6. Measure the distance (s) moved by the trolley along the inclined plane.
7. Determine the work done on the trolley when it is pulled up the inclined plane.
8. Discuss in your group, which of the three ways it was easier to lift the trolley.
9. Analyse what force balanced the force applied as the block was being pulled across the table.
10. Give examples where we use an inclined plane to lift loads.

An **inclined plane** also known as a ramp is a flat supporting surface tilted at one angle, with one end higher than the other used for raising or lowering loads. Fig. 6.10 below is an example of an inclined plane.

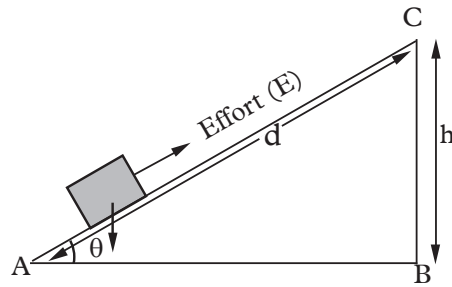

Fig. 6.10: Inclined plane

It is easier to lift a load from A to C by rolling or moving it along the plank than lifting it upwards from B to C.

Velocity ratio of an inclined plane

$$\text{Velocity ratio (V.R)} = \frac{\text{distance moved by effort (d)}}{\text{distance moved by load (h)}}$$

Mechanical advantage (M.A) of an inclined plane

If the inclined plane is **perfectly smooth (no friction)**, then the work done on load is equal to the work done by effort

$$\text{Work on load} = \text{Work done by effort}$$

$$\text{load} \times h = \text{effort} \times d$$

$$\frac{\text{load}}{\text{effort}} = \frac{d}{h}$$

$$\text{Hence mechanical advantage} = \frac{d}{h}$$

The ratio $\frac{d}{h}$ for an inclined plane is always greater than 1, hence its mechanical advantage is greater than 1. In practice, mechanical advantage is usually less than the calculated values due to frictional force.

The effect of length of an inclined plane on its mechanical advantage

Activity 6.6

To investigate how the length of an inclined plane affects its mechanical advantage

Materials: A trolley, inclined plane, masses

Steps

1. Measure the mass of a trolley. Place it on an inclined plane of length l , (Fig. 6.11). Add slotted masses until the trolley just begins to move up the plane.

- Record the values of the load, effort and the length l of the inclined plane.
- Repeat the activity with inclined planes of different lengths. Make sure the height, h , and the load are kept constant.

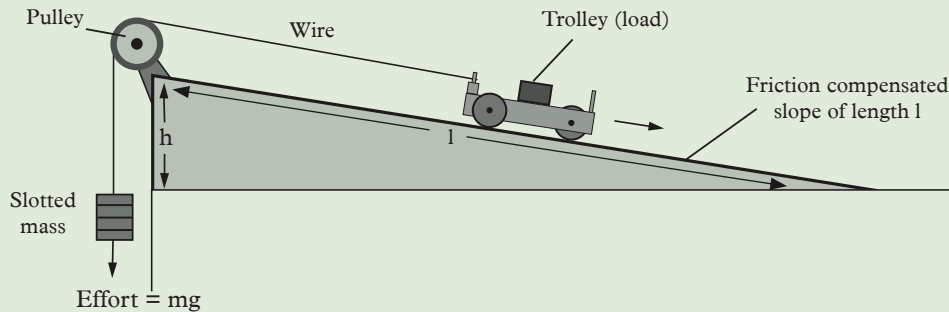

Fig. 6.11: How the length of inclined plane affects the mechanical advantage.

- Record your results in Table 6.1.

Table 6.1: Effort, length and MA values

Effort E (N)	Length, l	Mechanical advantage = $\frac{L}{E}$

- What happens to the applied effort when the length of the inclined plane is increased?

$$\begin{aligned} \text{Work done on the load} &= \text{load} \times \text{distance moved by the load} \\ &= L \times h \end{aligned}$$

$$\begin{aligned} \text{Work done on the effort} &= \text{effort} \times \text{distance moved by the effort} \\ &= E \times l \end{aligned}$$

But the work done on the load is equal to the work done by the effort i.e.

$$\begin{aligned} El &= Lh \\ \therefore E &= \frac{Lh}{l} = \frac{mgh}{l} \text{ since } L = mg \end{aligned}$$

$$\text{But } mgh \text{ is a constant: } \therefore E \propto \frac{1}{l} .$$

Therefore a small effort travels a long distance to overcome a large load.

6.3.3 Screws and bolts

Activity 6.7

To investigate the working of screws and bolts

(Work in pairs)

Materials: a screw, bolt, soft wood, a screw driver

Steps

1. Take a tapping screw and count the number of threads it has.
2. Use a screw driver to drive the screw into a soft wood. Once it reaches the end, remove it from the wood.
3. Feel the threads with your fingers.
4. Measure the depth of the hole made by the screw.
5. Measure the total length of all the threads.
6. Compare the length of the threads with the depth of the hole.
6. Count the number of threads.
8. Determine the distance between two consecutive threads (Suggest the name given to this distance).
9. How many revolutions does the screw head makes when the threads disappears completely into the wood?
10. Repeat the above steps using a bolt and a nut (Fig 6.12).
11. Discuss your findings with other groups in a class discussion.

Fig 6.12(a) shows a screw, bolt and nut.

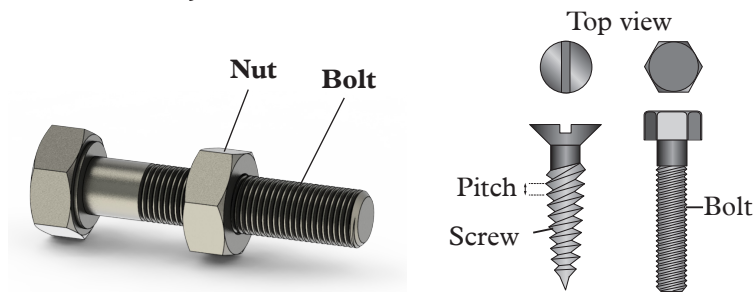

Fig. 6.12 (a): Screws, bolts and nut

The distance between the two successive threads is called **pitch**. When the screw is turned through one revolution by a force applied at the screw head, the lower end moves up or down through a distance equal to its pitch. The working of screws and bolts is based on the principle of an inclined plane.

Velocity ratio of a bolt

As the bolt is turned through one revolution, the screw moves one pitch up or down. The effort turns through a circle of radius R as the load is raised or lowered through a distance equivalent to one pitch (Fig. 6.13).

$$\begin{aligned}\text{Velocity ratio} &= \frac{\text{distance moved by effort}}{\text{distance moved by load}} \\ &= \frac{\text{circumference of a circle, } C}{\text{pitch (p)}} = \frac{2\pi R}{p}\end{aligned}$$

$$\text{V.R} = \frac{2\pi R}{p}$$

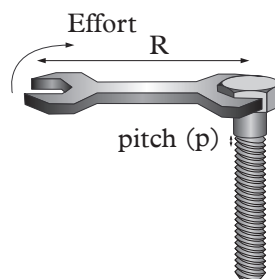

Fig. 6.13: Velocity ratio for a bolt

The effect of friction on mechanical advantage, velocity ratio and efficiency

From activity 6.7 you noticed that the threads felt warm after being driven into the wood. This means some of the work done was wasted as heat due to friction. The mechanical advantage of a machine depends on the frictional forces present, since part of the effort has to be used to overcome friction. However, the velocity ratio does not depend on friction but rather on the geometry of the moving parts of the machine. Consequently a reduction of mechanical advantage by friction reduces the efficiency of a machine.

6.3.4 The wheel and axle

Activity 6.8

To demonstrate action of wheel and axle

(Work in groups)

Materials: cylindrical rod, y-shaped branches, a stone, a string.

Steps

1. Construct a wheel and axle using locally available materials as shown in Fig. 6.14 below.

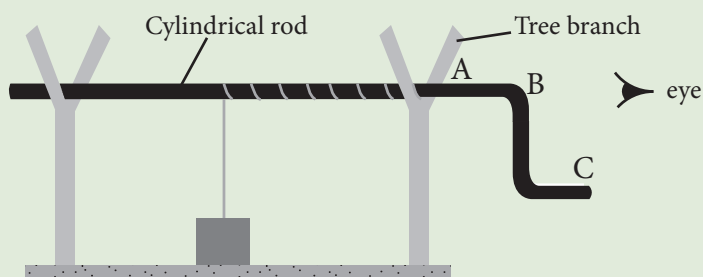

Fig 6.14: A wheel and axle

2. Turn the cylindrical rod at A to raise the stone. Is it easy to raise the stone by turning the rod at this point?
3. Repeat turning the cylindrical rod but this time by turning at C. What do you realise when raising the stone at this point of turn as compared to the previous point? Explain.
4. Compare the energy needed to turn the cylindrical rod in the two cases.
5. Which feature of the set-up represent the wheel and axle?
6. Observe the setup from B and draw the wheel, axle, load and effort.
7. Using various loads, find the force which in each case will just raise the load. Record your results in tabular form as shown in Table 6.2 below.

Load	Effort	M.A

Table 6.2: Values of load, efforts and N.A

8. Draw a graph of M.A against load.

Fig 6.15 shows simplified examples of wheel and axle.

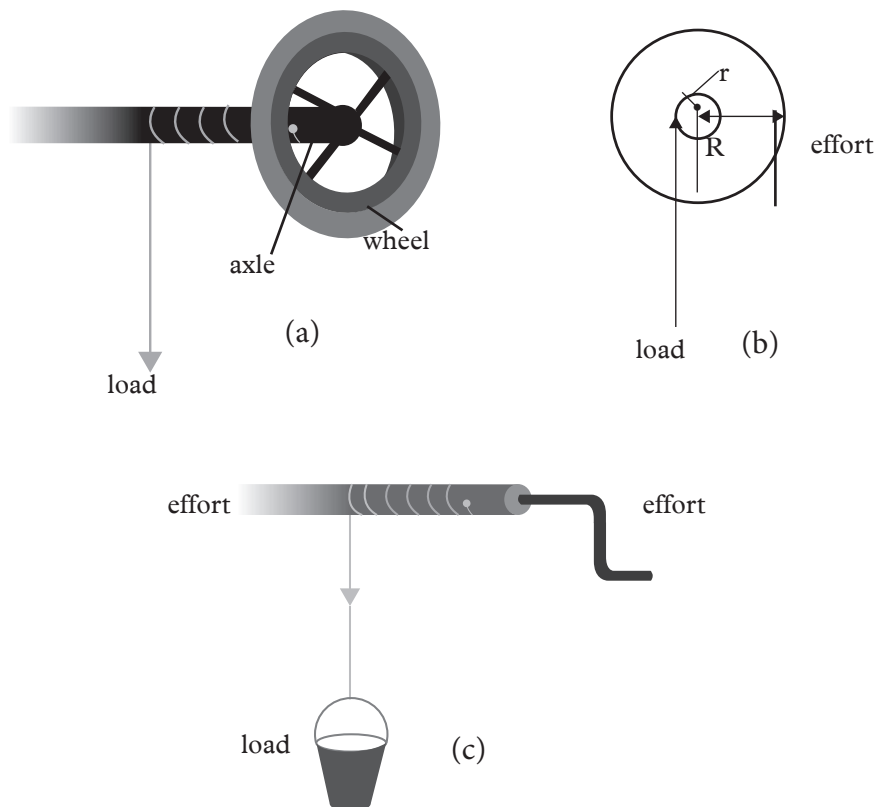

Fig 6.15: Simple wheel and axle

The wheel has a large diameter while the axle has a small diameter. The wheel and axle are firmly joined together and turn together on same axis. The effort is applied to the handle in the wheel. When the effort is applied, the axle turns, winding the load rope on the axle and consequently raising the load.

$$\text{Velocity ratio} = \frac{\text{distance moved by effort}}{\text{distance moved by load}} = \frac{2\pi \times \text{radius of wheel}(R)}{2\pi \times \text{radius of axle}(r)}$$

M.A may be obtained by taking moment

Load \times radius of axle = effort \times radius of wheel

$$\text{M.A} = \frac{\text{Load}}{\text{Effort}} = \frac{\text{radius of wheel}}{\text{radius of axle}} = \frac{R}{r}$$

Exercise 6.2

1. Give an example of a lever with a mechanical advantage less than 1. What is the real advantage of using such a machine?
2. Describe an experiment to determine the velocity ratio of a lever whose pivot is between the load and the effort.
3. An effort of 50 N is applied to drive a screw whose handle moves through a circle of radius 14 cm. The pitch of the screw thread is 2 mm. Calculate the:
 - (a) velocity ratio of the screw.
 - (b) load raised if the efficiency is 30%.

6.3.5 Pulleys

Activity 6.9

To demonstrate the action of a pulley

(Work in groups)

Materials: Reference books, flag, a flag post

Steps

1. Raise a flag up the flag post.
2. Explain how the flag post raises the flag.
3. We use a pulley to raise water from a well. Does it work the same way as the flag post?
4. Compare and discuss your findings with other groups in your class.
5. Let one of the group members present your findings to the whole class.

A pulley is usually a grooved wheel or rim. Pulleys are used to change the direction of a force and make work easy. There are three types of pulleys i.e. **single fixed pulley**, **single movable pulley** and **block and tackle**.

(a) Single fixed pulley

Fig. 6.16 shows a single fixed pulley being used to lift a load. This type of pulley has a fixed support which does not move with either the load or the effort. The tension in the rope is the same throughout. Therefore the load is equal to the effort if there is no loss of energy. The mechanical advantage is therefore 1. The only advantage we get using such a machine is convenience and ease in raising the load.

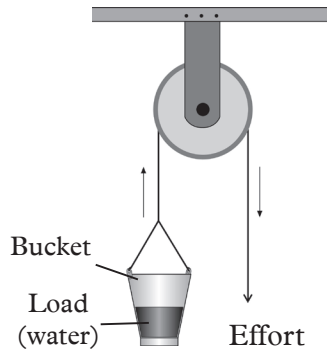
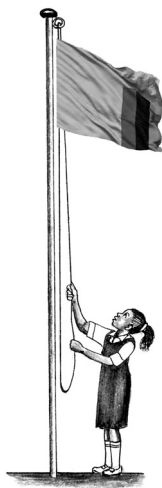
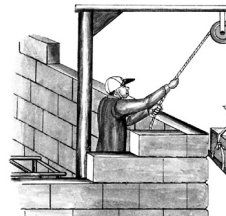

Fig. 6.16: Single fixed pulley

Since some energy is wasted due to friction and in lifting the weight of the rope, the mechanical advantage is slightly less than 1. The load moves the same distance as the effort and therefore the velocity ratio of a single fixed pulley is 1. Examples of real life applications of a single fixed pulley are as shown in Fig. 6.17.



(a) Raising a flag



(b) Raising bricks



(c) Raising water from a well

Fig. 6.17: Examples of single fixed pulley



Ensure you have covered the well/borehole in our homes after use. Its water may be polluted or even cause death due to accidents.

The single movable pulley

Fig.6.18 shows a single movable pulley. A movable pulley is a pulley-wheel which hangs in a loop of a rope. A simple movable pulley may be used alone or combined with a single fixed pulley. The total force supporting the load is given by the tension, T , plus effort, E , but since the pulley is moving up, the tension is equal to the effort.

Therefore, the upwards force is equal to twice the effort ($2E$). Hence the load is equal to twice the effort ($2E$).

$$\text{Mechanical advantage} = \frac{\text{load}}{\text{effort}} = \frac{2E}{E} = 2$$

However, since we also have to lift the pulley, the mechanical advantage will be slightly less than 2. Experiments show that the effort moves twice the distance moved by the load. Therefore,

$$\text{velocity ratio} = \frac{\text{Distance moved by effort}}{\text{Distance moved by load}} = 2$$

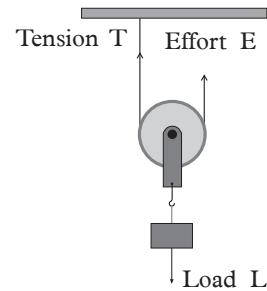
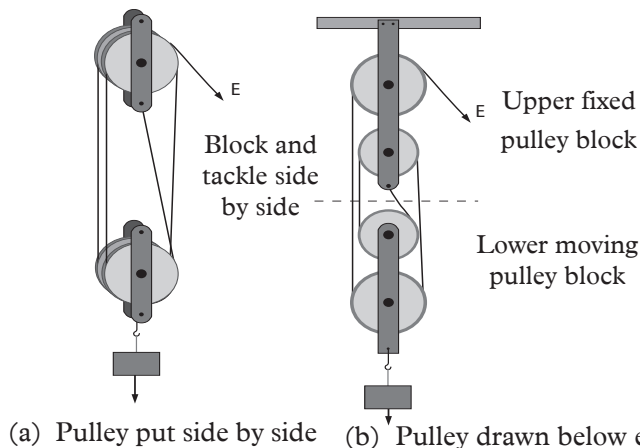

Fig. 6. 18: A single movable pulley

A block and tackle

A block and tackle consists of two pulley sets. One set is fixed and the other is allowed to move. The pulleys are usually assembled side by side in a *block* or frame on the same axle as shown in Fig. 6.19 (a). The pulleys and the ropes are called the *tackle*. To be able to see clearly how the ropes are wound, the pulleys are usually drawn below each other as shown in Fig. 6.19 (b).



(a) Pulley put side by side (b) Pulley drawn below each other

Fig. 6.19: Block and tackle systems.

Velocity ratio of a block and tackle

Activity 6.10

To determine velocity ratio of a block and tackle

(Work in groups)

Materials: A block and tackle pulley system, a load, a metre rule

Steps

1. Set up a block and tackle system with two pulleys in the lower block and two pulleys in the upper block as shown in Fig. 6.19 (b).
2. Count the number of sections of string supporting the lower block. Raise the load by any given length, l , by pulling the effort downwards. Measure the distance, e , moved by the effort. Record the result in a table. (Table 6.3).
3. Repeat the activity by increasing the distance moved by the effort. How does change of length affect the effort?
4. Plot a graph of e , against, l (Fig. 6.20). Determine the gradient of the graph.

Table 6.3: Distance by effort and distance by load

Distance moved by effort (e) in cm	Distance moved by load l cm
10	
20	
30	
40	

5. Compare the value of the gradient obtained with the number of sections of supporting strings. What do you notice? Explain.

From Activity 6.10, you should have observed that the distance moved by the effort is $\frac{1}{4}$ distance moved by the load.

The graph of effort against the load is as shown in Fig 6.20 below.

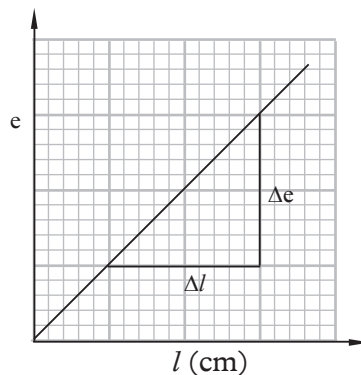

Fig. 6.20: Graph of the effort against the load.

The gradient $\frac{\Delta e}{\Delta l}$ which is the velocity ratio is found to be 4. When the value of the gradient is compared with the number of sections of string supporting the lower block, we note that they are the same i.e also 4.

Tip: The velocity ratio of a pulley system is equal to the number of strings sections supporting the load.

Precaution: The weight of the block in the lower section of the system has to be considered as this increases the load to be lifted.

Mechanical advantage of a block and tackle

Activity 6.11

To determine the mechanical advantage of a block and tackle

(Work in groups)

Materials: A block and tackle pulley, a load

Steps

1. Assemble the apparatus as in Fig. 6.19 shown in Activity 6.10 and connect a spring balance on the effort string. For a given load, pull the string on the effort string until the load just begins to rise steadily.
2. Repeat the activity with other values of load.
3. Record the values of the effort in a table (Table 6.4).

Table 6.4: Values of load (L), effort (E) and $\frac{L}{E}$

L	E	$\frac{L}{E}$

4. For each set of load and effort, calculate the mechanical advantage. Plot a graph of mechanical advantage against the load (Fig. 6.21). Describe the shape of the graph.

Fig 6.21 shows a graph of mechanical advantage against the load.

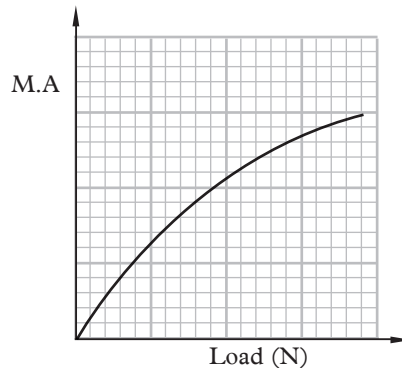

Fig. 6.21: Graph of mechanical advantage against the load

As the load increases, the mechanical advantage also increases. When the load is less than the weight of the lower pulley block, most of the effort is used to overcome the frictional forces at the axle and the weight of the lower pulley block. That is, the effort does useless work.

However, when the load is larger than the weight of the lower block, the effort is used to lift the load. This shows that the machine is more efficient when lifting a load that is greater than the weight of the lower block. Using the value of the velocity ratio obtained in Activity 6.11, calculate the efficiency of the pulley system. Plot a graph of efficiency against load (Fig. 6.22).

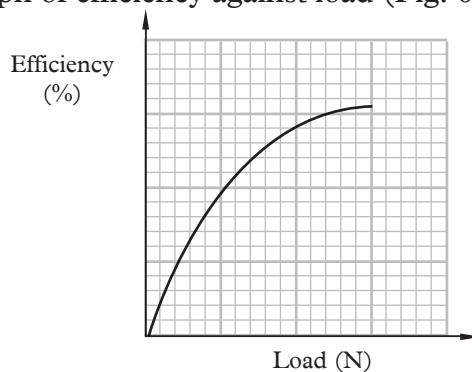

Fig. 6.22: The graph of efficiency against load

The efficiency of the system improves with larger loads.

Example 6.6

For each of the pulley systems shown in Fig. 6.23, calculate:

- (i) velocity ratio
- (ii) mechanical advantage
- (iii) efficiency

Solution

(a) (i) velocity ratio = 2 (number of sections of string supporting the lower pulley)

(ii) mechanical advantage

$$= \frac{200 \text{ N}}{150 \text{ N}}$$

$$= \frac{4}{3} = 1.33$$

(iii) efficiency = $\left(\frac{4}{3} \times \frac{1}{2}\right) \times 100\%$

$$= 66.7\%$$

(b) (i) velocity ratio = 5

(ii) mechanical advantage

$$= \frac{\text{load}}{\text{effort}}$$

$$= \frac{210 \text{ N}}{60 \text{ N}} = 3.5$$

(iii) efficiency

$$= \frac{3.5}{5} \times 100\%$$

$$= 70\%$$

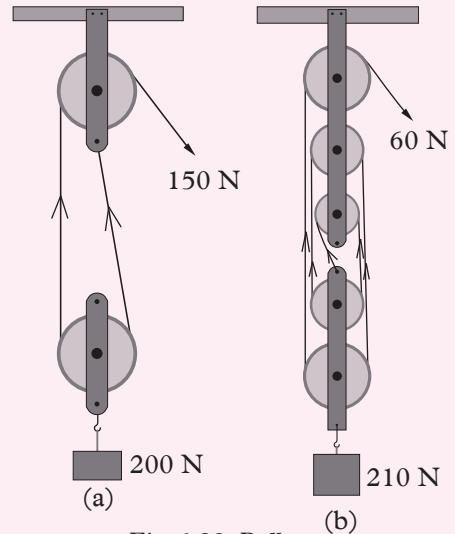

Fig. 6.23: Pulley system

Example 6.7

Draw a diagram of a single string block and tackle system with a velocity ratio of 6. Calculate its efficiency if an effort of 1 500 N is required to raise a load of 5 000 N.

Solution

See Fig. 6.24

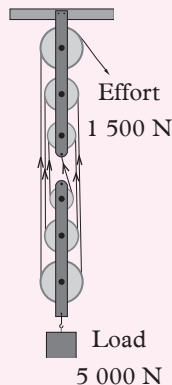

velocity ratio = 6

mechanical advantage = $\frac{5\,000 \text{ N}}{1\,500 \text{ N}} = \frac{10}{3}$

efficiency = $\frac{\text{M.A}}{\text{V.R}} \times 100 = \frac{10}{3} \times \frac{1}{6} \times 100$

$$= 55.6\%$$

Fig. 6.24: Block Tackle pulley system

Example 6.8

A block and tackle pulley system has a velocity ratio of 4. If its efficiency is 65%. Find the

- (a) mechanical advantage.
- (b) load that can be lifted with an effort of 500 N.
- (c) work done if the load is lifted through a vertical distance of 4.0 m.
- (d) average rate of working if the work is done in 2 minutes.

Solution

(a) $\text{efficiency} = \frac{\text{M.A.}}{\text{V.R.}} \times 100\%$

$$65 = \frac{\text{M.A.}}{4} \times 100\%$$

$$\text{mechanical advantage} = 2.6$$

(b) $\text{MA} = \frac{\text{load}}{\text{effort}}$

$$2.6 = \frac{\text{load}}{500}$$

$$\text{Load} = 1\,300 \text{ N}$$

(c) $\text{work} = \text{force} \times \text{distance in the direction of force}$

$$= 1\,300 \times 4$$

$$= 5\,200 \text{ J}$$

(d) $\text{Rate of doing work} = \text{Power}$

$$\text{Power} = \frac{\text{work done}}{\text{time}}$$

$$= \frac{5\,200}{120} = 43.3 \text{ W}$$

Exercise 6.3

- 1. (a) Draw a system of pulleys with two pulleys in the lower and upper block.
(b) Describe how you would find experimentally its mechanical advantage.

- 2. Fig. 6.25 shows a pulley system.

Find;

- (a) the velocity ratio of the pulley system.
- (b) the mechanical advantage, if the system is 80% efficient.
- (c) the effort.
- (d) the work done by the effort in lifting the load through a distance of 0.6 m.
- (e) how much energy is wasted?

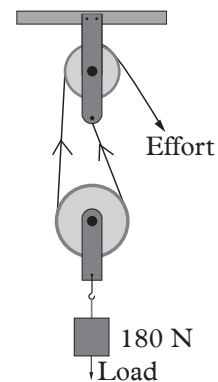

Fig. 6.25: Pulleys system

3. A pulley system has a velocity ratio of 3. Calculate the effort required to lift a load of 600 N, if the system is 65% efficient.
4. A pulley system has a velocity ratio of 4. In this system, an effort of 68 N would just raise a load of 216 N. Find the efficiency of this system.

Topic summary

- A **machine** is a device that makes work easier.
- Mechanical advantage (M.A) is the **ratio of load to effort**.
- Mechanical advantage = $\frac{\text{load}}{\text{effort}}$.

The mechanical advantage of a machine depends on loss of energy of the moving parts of a machine. Mechanical advantage has no units.

- Velocity ratio (V.R) is **the ratio of distance the effort moves to that moved by the load**.

$$\text{Velocity ratio} = \frac{\text{Distance moved by the effort}}{\text{Distance moved by the load}}$$

Velocity ratio is a ratio of similar quantities hence it has no units.

- Theoretical value of velocity ratio may be obtained from the dimensions of the machine e.g. in pulleys—number of the sections of string supporting the load.

Table 6.5: Expressions for velocity ratio of various machinery

Machine	VR
Inclined plane	$\frac{1}{\sin \theta}$
Screw	$\frac{2\pi r}{\text{pitch, } P}$
Wheel and axle	$\frac{\text{Radius of wheel, } R}{\text{Radius of axle, } r} = \frac{R}{r}$

- Efficiency = $\frac{\text{work output}}{\text{work input}} \times 100\% = \frac{\text{mechanical advantage}}{\text{velocity ratio}} \times 100\%$

Topic Test 6

1. Define the following terms:

- | | |
|---|---|
| <p>(a) Power of a machine</p> <p>(c) Mechanical advantage (M.A)</p> | <p>(b) Efficiency</p> <p>(d) Velocity ratio (V.R)</p> |
|---|---|

2. A farmer draws water from a well using the machine shown in Fig. 6.26 below. The weight of the bucket and water is 150 N. The force, F exerted by the farmer is 160 N. The bucket and its content is raised through a height of 15 m.

- (a) What is the name given to such a machine?
- (b) Why is the force, F , larger than the weight of the bucket and water?
- (c) What distance does the farmer pull the rope?
- (d) How much work is done on the bucket and water?
- (e) What kind of energy is gained by the bucket?
- (f) How much work is done by the farmer?
- (g) Where does the energy used by the farmer come from?
- (h) Show with a flow diagram the energy conversion in lifting the water from the well.

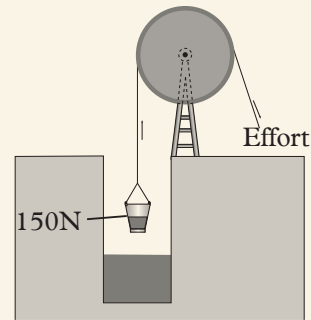

Fig. 6.26: A simple pulley system

3. A factory worker lifts up a bag of cement of mass 50 kg, carries it horizontally then up a ramp of length 6.0 m onto a pick-up and finally drops the bag of cement on the pick-up (Fig. 6.27).

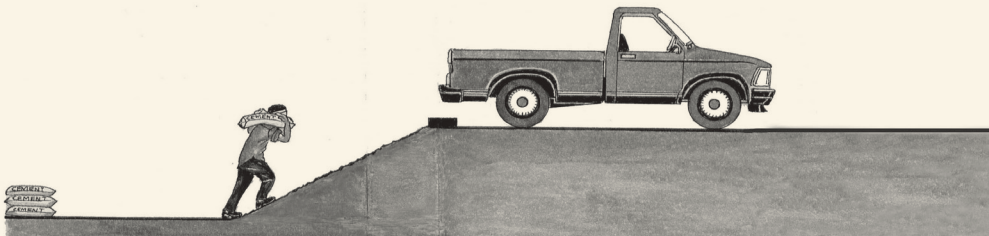

Fig. 6.27: Worker lifting cement on the pick-up

- (a) Explain the energy changes in the various stages of the movement of the worker.
- (b) During which stages is the worker doing work on the bag of cement.

- (c) If the worker has a mass of 60 kg and the ramp is 1.5 m high, find the
- velocity ratio.
 - efficiency of the inclined plane if the mechanical advantage is 3.
4. Fig. 6.28 shows the cross-section of a wheel and axle of radius 6.5 cm and 1.5 cm respectively used to lift a load. Calculate the efficiency of the machine.

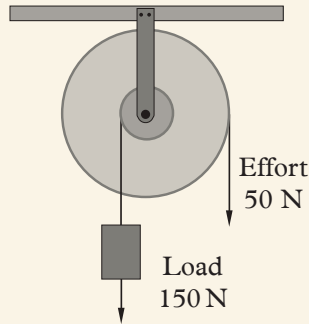

Fig. 6.28: Wheel and axle

5. A student wanted to put 10 boxes of salt at the top of the platform using an inclined plane (Fig. 6.29).

If the resistance due to friction is 10 N, calculate

- the work done in moving the 10 boxes.
- the efficiency of this arrangement.
- the effort required to raise one box to the platform.

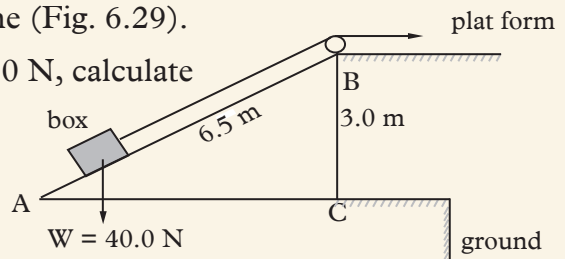

Fig. 6.29: A crane

6. A crane just lifts 9 940 N when an effort of 116 N is applied. The efficiency of the crane is 65%. Find its:
- mechanical advantage
 - velocity ratio
7. Fig. 6.30 shows a pulley system. An effort of 113 N is required to lift a load of 180 N.

- What distance does the effort move when the load moves 1 m?
- Find the work done by the effort.
- Find the work done on the load.
- Calculate the efficiency of the system.

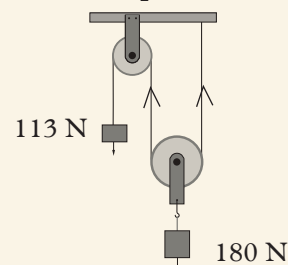

Fig 6.30 A pulley system

8. The Fig. 6.31 shows a single fixed pulley.

Calculate its:

- (a) V.R
(b) Efficiency

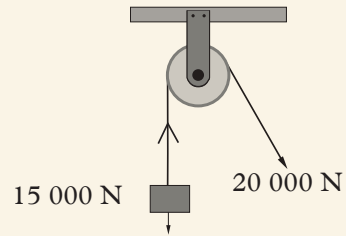

Fig 6.31: Single fixed pulley

9. In the system shown in Fig. 6.32, the winding machine exerts a force of 2.0×10^4 N in order to lift a load of 3.2×10^4 N.

- (a) What is the velocity ratio?
(b) Calculate the M.A.
(c) Find the efficiency.

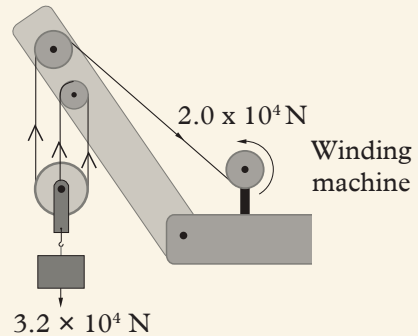

Fig. 6.32: A winding crane

10. Fig. 6.33 shows a pulley system.

- (a) What is the velocity ratio of the system?
(b) Calculate the efficiency of the system.
(c) Show the direction of the force on the string.

11. A block and tackle pulley system has five pulleys. It is used to raise a load through a height of 20 m with an effort of 100 N. It is 80% efficient.

- (a) Is the end of the string attached to the upper or lower block of pulleys if the upper block has three pulleys? Show it in a diagram.
(b) State the velocity ratio of the system.
(c) Calculate the load raised.
(d) Find the work done by the effort.
(e) Find the energy wasted.

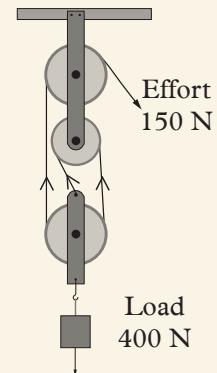

Fig. 6.33: A block and tackle pulley

12. A man pulls a hand cart with a force of 1 000 N through a distance of 100 m in 100 s. Determine the power developed.

Topics in the unit

Topic 7: Introduction of waves

Topic 8: Sound waves

Learning outcomes**Knowledge and Understanding**

- Understand and explain the motion, types and properties of waves

Skills

- Design tests to investigate waves using strings and ripple tanks.
- Observe carefully
- Predict cause and effect
- Use appropriate measures
- Collect and present results including representing waves in displacement-position and displacement-time graphs
- Interpret results accurately
- Report findings appropriately

Attitudes

- Appreciate the wave motion and that there are certain features common to all waves.
- Appreciate use of ultrasound in medical diagnosis and radar.

Key inquiry questions

- What constitute a wave?
- What parameters characterize a wave?
- What evidence is there that wave exists?
- How can we apply our knowledge of waves?

Unit outline >>>

- Oscillations
- Characteristics of oscillations
- Factors affecting oscillations
- Types of waves
- Characteristics of wave motion

Introduction

When a stone is dropped in a pool of still water, ripples spread out in a circular form. This constitutes what is called *water waves*. There are many different types of waves that we make use of such as light and sound waves, microwaves, infrared and radio waves used to transmit radio and television signals.

In this unit, we shall study the production of waves and some common terms and properties used in describing wave motion. By understanding more about waves, more uses are made of them. The study of waves begin with the concept of oscillations.

7.1 Oscillations

Movements form a major part in our lives. Movements can be regular or irregular. Some movements follow a fixed path and keep repeating. These kinds of movements are important in our lives as shown in the following examples:

- A pendulum clock repeats movement to keep time.
- Wheels of bicycles and vehicles keep repeating their movements round in a circular path and this makes them to move faster and easily to other places.
- Heartbeats are also rhythmic movements that help us remain alive.
- Swings in children's playgrounds.

All these and many others are repetitive to-and-fro movements called **oscillations**. Therefore, *oscillations are repeated, regular movements that happen at a constant rate.*

7.1.1 Characteristics of an oscillation

- The *displacement, d* , of a vibrating body is the distance of that body from the mean/fixed position.
- The *amplitude, a* , of a vibration is the maximum displacement from the fixed/mean position in either direction.
- *Periodic time, T* , is the time taken to complete one oscillation or cycle.
- The *frequency, f* , is the number of complete oscillations (or cycles) made in one second. SI unit for frequency is the *hertz, Hz* . One hertz is defined as *one oscillation per second or one cycle per second*.

Consider the following cases of oscillations:

(a) A simple pendulum

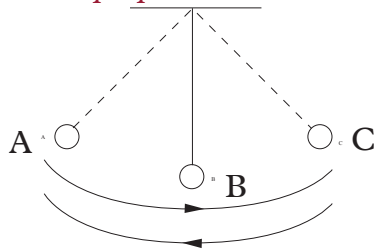

One oscillation is the movement

$A \rightarrow B \rightarrow C \rightarrow B \rightarrow A$

Amplitude is the distance BA or BC.

Fig. 7.1: A simple pendulum

(b) A vibrating spring

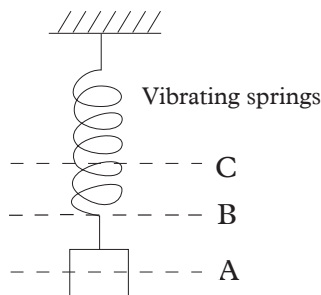

One oscillation is the movement

$A \rightarrow B \rightarrow C \rightarrow B \rightarrow A$.

The amplitude is the distance BA or BC.

Fig. 7.2: A vibrating spring

(c) A clamped metre rule

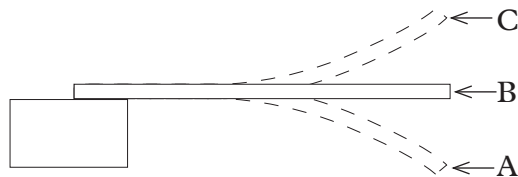

One oscillation is the movement

$A \rightarrow B \rightarrow C \rightarrow B \rightarrow A$.

The amplitude is the distance BA or BC.

Fig. 7.3: A clamped rule

7.1.2 Factors affecting oscillations

Activity 7.1

To investigate how length affects the rate of oscillation

(Work in groups)

Materials: Bob, stand, string

Steps

1. Set up apparatus as shown in Fig. 7.4 showing a simple pendulum consisting of a bob attached at the end of a light cord. The other end of the string is clamped rigidly in position.
2. Displace the bob slightly to one side then release it and observe what happens.
3. Increase the length of the cord the change in vibration time. Why do you think there is change in vibration time?
4. Repeat this several times.

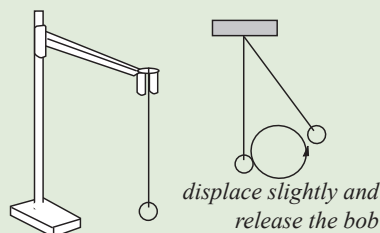

Fig. 7.4: Simple pendulum

We observe that the longer the cord of the pendulum, the slower it oscillates.

Activity 7.2

To investigate how mass affects the rate of oscillation

(Work in groups)

Materials: Stand, mass, spring and clamp

Steps

1. Attach a mass to one end of a spiral spring whose other end is rigidly clamped in position Fig. 7.5. Pull the mass slightly downwards then release it and observe what happens.
2. Repeat this activity three times each time using a bigger mass.
3. How does the change in mass affect the rate of oscillations? Explain.

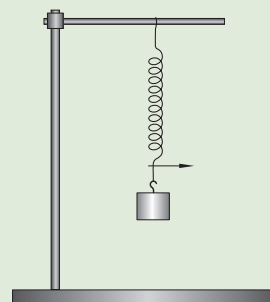

Fig. 7.5: Hanged spiral spring

The bigger the mass, the slower the vibration of the spring.

Activity 7.3

To investigate how frequency affects the rate of oscillation

(Work in groups)

Materials: G-clamp, mass,

Steps

1. Fix a mass at the end of a metre rule and clamp the other end as shown in Fig. 7.6.

2. Displace the free end of the rule then release and observe what happens. Repeat this activity by attaching another mass two more times.
3. Repeat this activity using half of the metre rule.
4. How does frequency affect the rate of Oscillation? Explain.

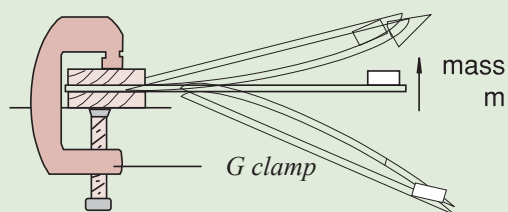

Fig. 7.6: Oscillations of a loaded metre rule.

From the Activities

- (a) the bigger the mass, the slower the ruler swings.
- (b) the longer the ruler, the slower it swings.

All the above activities indicate that the frequency of a vibrating system is affected by:

- (a) Length – the longer or larger the body the lower the frequency e.g a shortened guitar wire produces higher pitch.
- (b) Mass – the bigger the mass /thickness the lower the frequency (longer periodic time). This is usually the case in guitar wires, where thinner ones give higher pitch. Note that a pendulum is not affected by mass of the bob attached.
- (c) It can be shown that increase in tension increases the frequency /pitch of a vibrating body for example a string /wire.

7.2 The concept of a wave

There are many cases in real life where energy produced at one place is consumed at a different place. In such cases, the energy need to be transferred from the place of production to the place of consumption. This can take place in a number of different ways including:

- Physically moving the matter carrying the energy and delivering it to the place where the energy is to be consumed.
- Vibration of the particles of a medium leading to transfer energy from one particle to next. In this topic, will learn more about this mode of energy transfer.

If a stone is thrown into a still swimming pool or pond, circular water ripples are seen moving from the point where the stone hit the water outwards to the banks. This implies that the energy from the stone is transferred from the hitting point to other regions through the ripples. Such ripples are examples of **waves**.

What is a wave?

A wave can be defined as “a periodic disturbance (movement) that transfers energy from one point to another with no net movement of the medium particles.”

Examples of waves include sound waves, water waves, light waves, radio waves, X-rays, gamma rays, seismic waves and microwaves.

7.2.1 Formation of waves and pulses

Formation of wave motion

As learnt earlier, waves transfer energy but not matter. This energy is transferred through pulses and waves. A pulse is a sudden short-lived disturbance in matter. Wave or wave train is a continuous disturbance of the medium which arises due to regular pulses being produced. The following experiments demonstrate wave motions.

Formation of pulses

A pulse is a single wave disturbance that moves through a medium from one point to the next point. Let us now demonstrate the formation of pulse in Activity 7.4.

Activity 7.4

To demonstrate the formation of pulses using a rope

(Work in groups)

Materials: Rope, pins, nails, helical springs and table

Steps

1. Fix one end of a rope to a wall. Hold the free end of the rope so that the rope is fully stretched.
2. Quickly move your hand upwards and then return to the original position as shown in Fig. 7.7(a). Observe what happens to the rope.
3. Now move your hand suddenly downwards and return to the original position as in Fig. 7.7(b). Observe what happens to the rope.

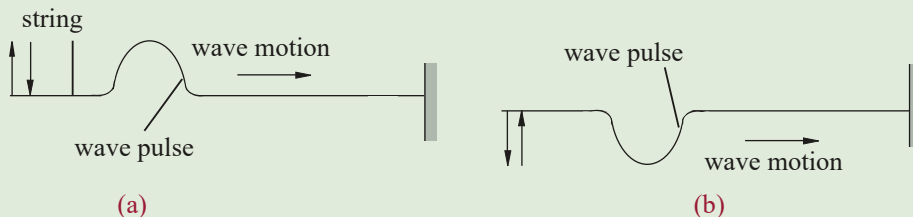

Fig. 7.7: Production of a pulse using a rope

4. Tie one end of the rope to the fixed pole as shown in Figure 7.8.

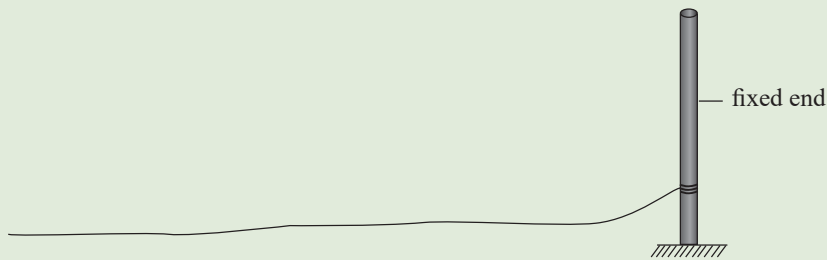

Fig. 7.8: A rope fixed at one end

5. Hold the free end of the rope and shake it in an up and down motion. Observe how the rope behaves and explain the motion.
6. Place the helical spring to lie on a table and hold it firmly to the table on one end.
7. Gently pull the free end then push it repeatedly while keenly observing what happens. Explain your observation. What do you think can behave the same way as the spring when compressed?

In Activity 7.4, we notice that pulses that move from one end of the rope to the other are produced.

If the disturbance is continuous waves or wave trains are formed.

When pulses are produced regularly and give rise to a continuous wave motion. Waves or a *wave train* is a continuous disturbance of the medium which arises due to the regular pulses being produced. In Activity 7.4, when the hand (*source*) is moved continuously up and down or forward and backward, the particles of the rope or spring (*medium*) also move up and down or forward and backward. When the source is moved at regular intervals, the disturbance is also produced at regular intervals (Fig. 7.9).

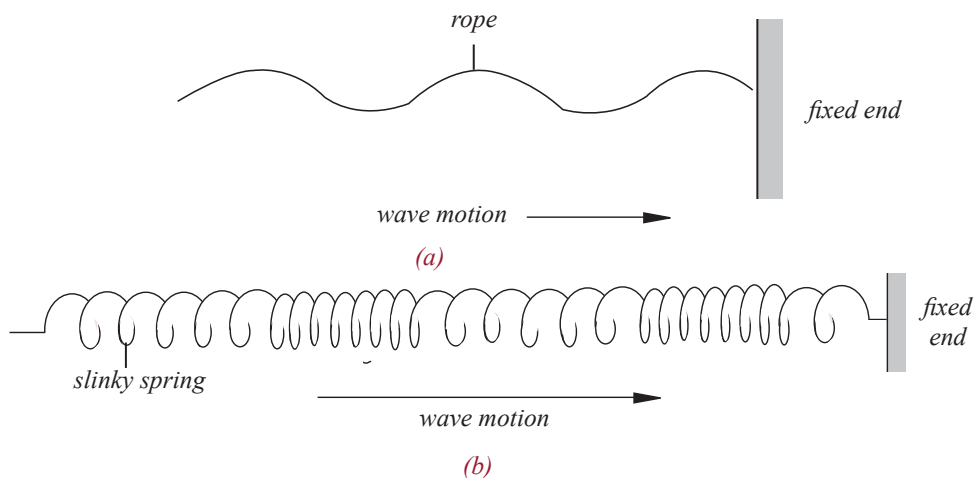

Fig. 7.9: Production of continuous pulses in a string and a slinky

Continuous disturbance of a medium at a point produce continuous waves or wave trains. The waves or wave trains produced are of two types: *transverse waves* and *longitudinal waves*.

Types of waves

There are two types of waves namely; **Mechanical waves** and **Electromagnetic waves**.

Electromagnetic waves

These are waves that do not require a medium to travel from one point to another. They can travel through empty space (vacuum). Examples of electromagnetic waves are X-rays, gamma rays, visible light etc. They are produced by electric and magnetic fields.

Mechanical waves

These are waves which require a medium to travel from one point to another. They are produced by vibrating objects. They are transmitted by the vibration of the medium particles. Such waves can be seen or felt. Example of mechanical waves include waves on a rope or spring, water waves, sound waves in air, waves on a spring, seismic wave etc.

A mechanical wave can be a *progressive* or *stationary* wave. A **progressive** (travelling) **wave** is a disturbance which carries energy from one place to another without transferring matter.

There are two type of progressive mechanical waves: **Transverse** and **Longitudinal waves**.

(a) Transverse waves

Transverse waves are mechanical waves in which the particles of the medium move in a direction perpendicular to the direction of travel of the wave. Therefore, in a transverse wave, the direction of disturbance is at right angles to the direction of travel of the wave.

From Activity 7.4, we notice that when the rope is shook up and down, it is seen to make rises and falls which move through the fixed end (Fig. 7.10).

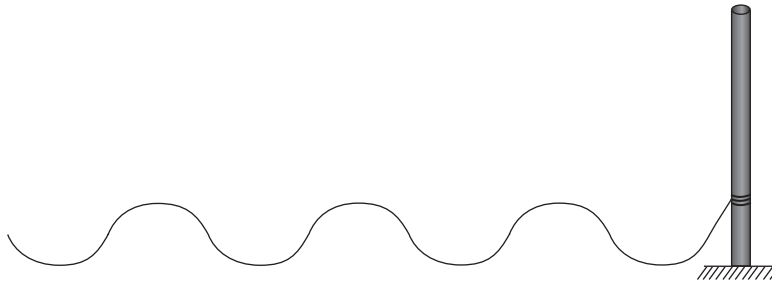

Fig. 7.10: A rope in motion

The rope particles are displaced up and down as they move towards the fixed end. These up and down disturbance are perpendicular to the direction of motion of the wave. The rises are known as **crests** while the falls are known as **troughs** (Fig. 7.11).

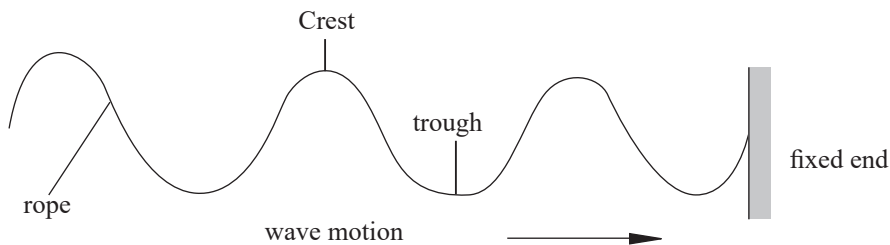

Fig. 7.11: Transersal waves

(b) Longitudinal waves

Longitudinal waves are mechanical waves in which particles of the medium move in direction parallel to the direction of the wave motion. The particles of the transmitting medium vibrates to and fro along the same line as that in which the wave is travelling.

From Activity 7.4, we notice that when the spring is compressed gently, the coils are observed to move towards the fixed end. In some regions, the coils are close together while in other regions the coils are far apart as shown in Fig. 7.12. The region where the coil are close together are known as a **compressions** while the regions where they are far apart are known as **rarefactions**. (See Fig 7.12 (a) and (b))

(a)

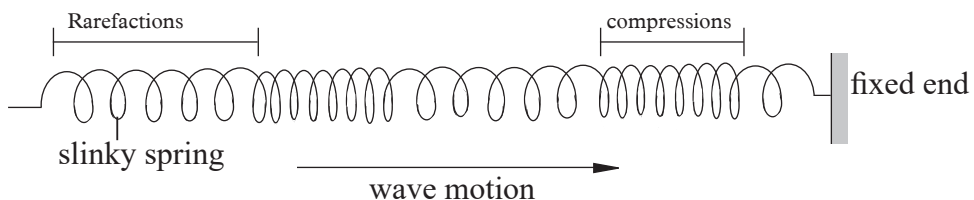

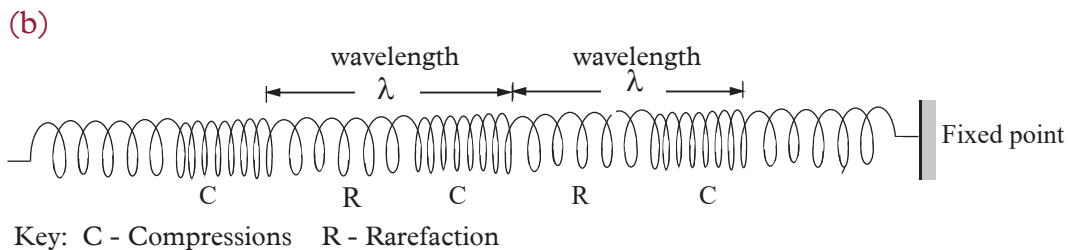

Fig. 7.12: Longitudinal wave

Thus, a longitudinal wave consists of **compressions** and **rarefactions**.

Compressions is a region on a longitudinal wave with a high concentration of vibrating particles. On the other hand **rarefaction** is a region of the longitudinal wave with low concentration of vibrating particles. Example of longitudinal wave is sound waves.

Figure 7.13 shows a longitudinal plane waves.

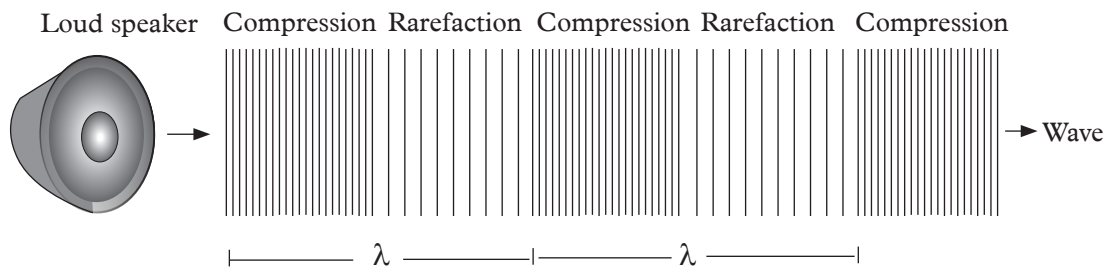

Fig. 7.13: shows a longitudinal plane waves

Differences between Transverse and Longitudinal waves

Table 7.1: Difference between transverse and longitudinal waves

Transverse waves	Longitudinal waves
Particles of the medium are displaced perpendicular to the direction of motion of the wave.	Particles of the medium are displaced parallel to the direction of motion of the wave.
Form crests and troughs.	Form compressions and rarefactions.
Example include: Electromagnetic waves, water waves, waves made by a rope when its moved up and down.	Example include: sound waves, waves made by a spring when pushed.

Exercise 7.1

1. What is an oscillation?
2. Distinguish between a pulse and wave train.
3. What factors affect the frequency of an oscillating:
 - (a) pendulum
 - (b) mass – spring system

4. Define the term 'wave'.
5. Differentiate between transverse and longitudinal waves giving an example for each.
6. Name the type of wave found in the following activities:
 - (a) Children playing rope jumping.
 - (b) A spring being displaced forward and backward.
 - (c) Waves due to dropping a stone into water on a basin.
 - (d) A car moving on a bump.
7. Distinguish between compression and rarefaction
8. Briefly explain how a pulse is formed.
9. Name two factors that affect oscillations of an object.

7.3 Characteristics of wave motion

Wavelength of transverse waves

Consider a long rope with one of its ends rigidly tied to a peg while the other end is free. Produce a pulse by moving the hand upwards and notice the distance travelled by the disturbance. If the hand is moved up and down once through a complete cycle, the time taken by the hand is the *periodic time (T)*.

Fig. 7.14 shows a graph of displacement of particles against time. We see that the particles of the rope just vibrate up and down about their mean or rest position, but do not move with the wave. The disturbance is transferred from particle to particle. The distance travelled by the disturbance (wave energy) during each periodic time T is called the *wavelength, λ* , of the wave.

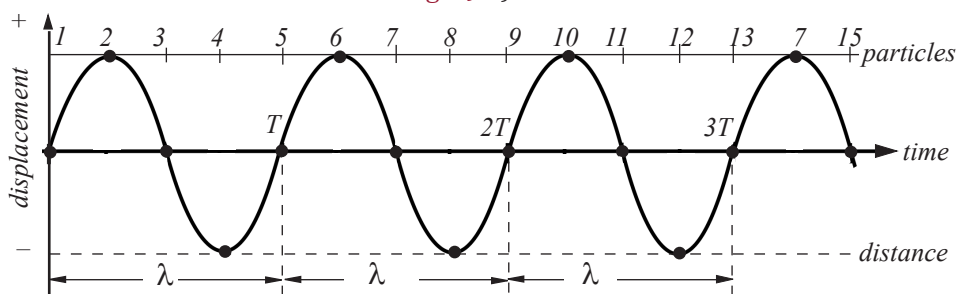

Fig. 7.14: Wavelength of a transverse wave.

From the graph (Fig. 7.14), particles 2, 6, 10, 14, etc. are at similar positions and move in the same direction. Such positions are called the *crests* of a wave. Similarly, particles 4, 8, 12 etc, are at similar positions and are moving in the same direction. Such positions are called the *troughs* of a wave.

Particles that are at similar positions and are moving in the same direction are said to be in *phase*.

A crest is the position of maximum positive displacement, and a trough is the position of maximum negative displacement as shown in Fig. 7.15.

The distance between two successive particles in phase such as two successive crests or troughs is equal to the *wavelength* of the wave.

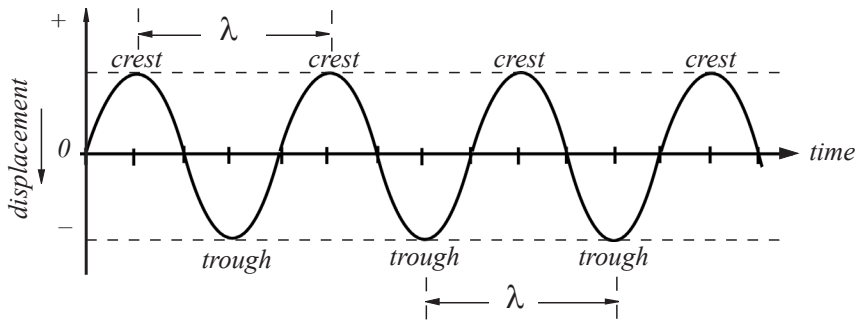

Fig. 7.15: Crest and troughs in a transverse wave

Wavelength of a longitudinal wave

Fig. 7.16 shows the energy propagation in a slinky spring.

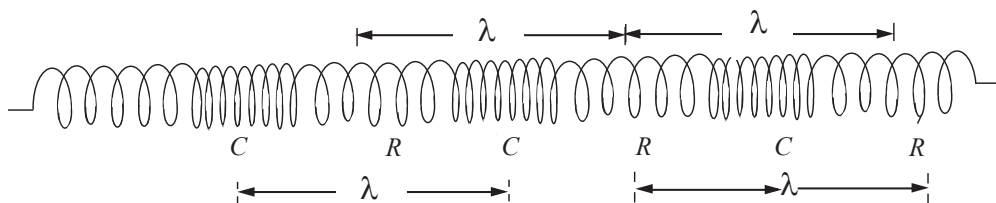

Fig. 7.16: Compressions and rarefactions in a longitudinal wave.

Just like the production of crests and troughs in a transverse wave, we have the regions of compressions (C) and rarefactions (R) in a longitudinal wave.

A *compression* is a region where the particles of the medium are closely packed. In this region, the pressure of the particles of the medium is high, hence the density is high.

A *rarefaction* is the region where the particles of the medium are spread out. In this region the pressure of the particles of the medium is low, hence the density is low.

The wavelength of a longitudinal wave can be described as the distance between two successive compressions or rarefactions.

Fig. 7.17 is a displacement -time graph for a wave. We will use it to describe other characteristics of waves.

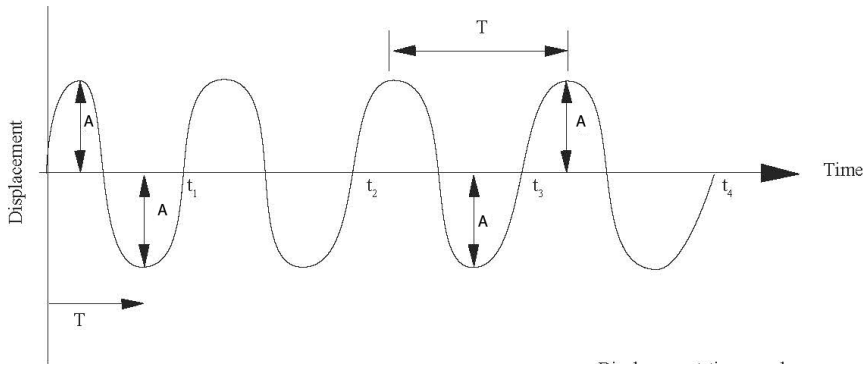

Fig. 7.17: Displacement – Time graph

Periodic time, T

The time taken for one vibration /oscillation. It is also the time taken to cover a distance of one wave length. Thus, the value of T in Fig. 7.17 is the periodic time. By definition, periodic time is the duration for one complete oscillation.

Amplitude, (A)

As a body or particles vibrate, they change position from the mean rest position. The position of a point from the resting position at any given time is called its *displacement*.

The maximum value of displacement is called *amplitude* (A) as shown on the Fig. 7.17.

Frequency, (f)

Frequency (f) is the number of cycles made per unit time. We can write this mathematically as,

$$\text{Frequency (f)} = \frac{\text{number of vibrations (n)}}{\text{time taken (t)}}$$

$$\text{In symbols, } f = \frac{n}{t}$$

If $n = 1$ (i.e 1 oscillation), then $t = T$ (periodic time)

$$\text{Hence } f, = \frac{1}{T} \text{ and } T = \frac{1}{f}$$

For example, if a newborn baby's heart beats at a frequency of 120 times a minute, its

$$\text{frequency is } f = \frac{120}{60} = 2 \text{ Hz and } T = \frac{1}{f} = \frac{1}{2} = 0.5 \text{ s}$$

Speed of wave

This is the distance covered by a wave per unit time. It is measured in metres per second, (m/s).

The speed of wave is given by:

$$\text{Wave speed} = \frac{\text{distance travelled by a wavetrain}}{\text{time taken}}$$

Phase of a wave – is the fraction of wave cycle which has elapsed relative to the origin.

The wave equation

Consider a source that produces n waves of wavelength (λ) in period time (T) seconds (Fig. 7.18)

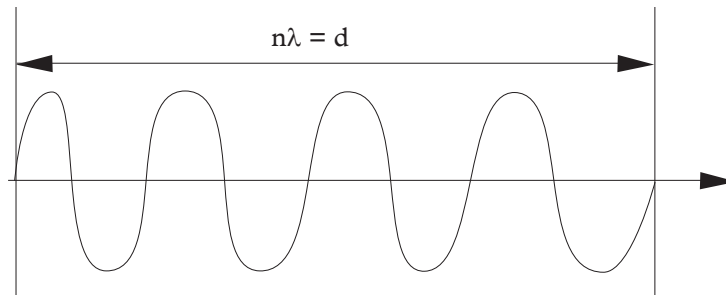

Fig. 7.18: Displacement – distance graph

The distance travelled by a wave train in one period time is the wavelength of a wave.

$$\text{Wave speed, } v = \frac{\text{distance travelled}}{\text{time taken}}$$

Thus, the velocity of the wave is given by:

$$\text{velocity (v)} = \frac{n\lambda}{T} \dots\dots\dots(i)$$

$$\text{but } \frac{n}{T} = f$$

$$\text{Substituting for T in (i), we get } v = \frac{\lambda}{\frac{1}{f}} = \lambda f$$

$$\text{Thus, } v = f\lambda$$

The speed of a wave is given by: Frequency \times wavelength

The equation $v = f\lambda$ is called the *wave equation*. This formula holds for all waves.

Example 7.1

A slinky is made to vibrate in a transverse mode with a frequency of 4 Hz. If the distance between successive crests of the wave train is 0.7 m calculate the speed of the waves along the slinky.

Solution

$$\lambda = 0.7\text{m}, f = 4\text{Hz}$$

$$\begin{aligned}\text{Wave speed} &= \text{frequency} \times \text{wavelength} \\ &= 4\text{Hz} \times 0.7\text{m} \\ &= 2.8 \text{ m/s}\end{aligned}$$

Example 7.2

Calculate the frequency of a wave if its speed is 30 cm/s and the wavelength is 6 cm.

Solution

$$\text{Wave speed} = \text{frequency} \times \text{wavelength}$$

$$v = f \times \lambda$$

$$f = \frac{v}{\lambda} = \frac{30}{6} = 5 \text{ Hz}$$

Example 7.3

A source of frequency 256 Hz is set into vibrations. Calculate the wavelength of the waves produced, if the speed of sound is 332 m/s in air.

Solution

$$v = f \times \lambda$$

$$\lambda = \frac{v}{f} = \frac{332}{256} = 1.30 \text{ m.}$$

Example 7.4

The speed of a certain wave in air is 3×10^8 m/s. The wavelength of that wave is 5×10^{-7} m. Calculate the frequency of that wave.

Solution

$$v = f \lambda$$

$$f = \frac{v}{\lambda} = \frac{3 \times 10^8}{5 \times 10^{-7}} = 0.6 \times 10^{15} \text{ Hz} = 6.0 \times 10^{14} \text{ Hz}$$

Example 7.5

Fig. 7.19 shows a wave produced in a string.

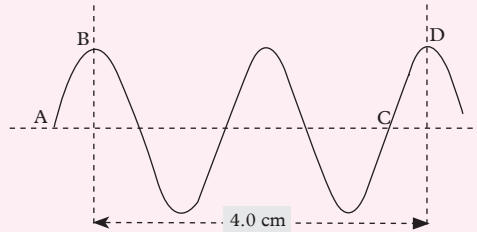

Fig. 7.19

- (i) Calculate the wavelength of the wave.
- (ii) If ten complete waves are produced in a duration of 0.25 seconds, calculate the speed of the waves.

Solution

(i) Wavelength (λ) = $\frac{\text{length of a number of waves}}{\text{number of waves}} = \frac{4 \text{ cm}}{2} = 2 \text{ cm}$

(ii) $f = \frac{10}{0.25} = 40 \text{ Hz}$

$v = f\lambda = 0.02 \times 40 = 0.8 \text{ m/s}$

Example 7.6

Fig. 7.20 shows the displacement–time graph of a wave travelling at 200 cm/s.

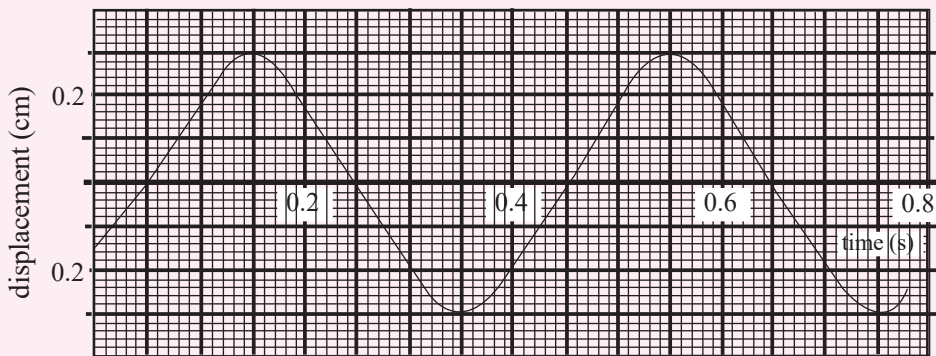

Fig. 7.20: Displacement – time graph

Determine the:

- (a) amplitude
- (b) Period
- (c) frequency
- (d) wavelength

Solutions

(a) 0.3 cm

(b) $T = 0.4 \text{ s}$

(c) $f = \frac{1}{T} = 2.5 \text{ Hz}$

(d) $\lambda = \frac{v}{f} = \frac{2.00}{2.5} = 0.8 \text{ m}$

Example 7.7

A spring vibrates at the rate of 20 cycles every 5 seconds

(a) Calculate the frequency of the waves produced.

(b) If the wavelength of the waves is 0.01 m, find the speed of the waves.

Solutions

(a) 20 cycles = 5 seconds

4 cycles = 1 second

$\therefore f = 4 \text{ Hz}$

(b) $v = f\lambda$

$= 4 \times 0.01$

$= 0.04 \text{ m/s}$

Exercise 7.2

1. Draw a wave and mark on it the wavelength and amplitude.
2. Explain the phrase 'a wave has a frequency of 5 Hz'.
3. A flag is fixed in an ocean. If two waves pass the flag every second, what is
 - (a) its frequency?
 - (b) the period of the water waves?
4. Derive the wave equation.
5. A sound wave has a frequency of 170 Hz and a wavelength of 2 m. Calculate the velocity of this wave.
6. The range of frequencies used in telecommunication varies from 1.0×10^6 to 2.0×10^7 Hz. Determine the shortest wavelength in this range. (The Speed of the wave is 3×10^3 m/s).
7. The speed of sound in air is 320 m/s. Calculate the frequency of sound when the wavelength of sound is 60 cm.
8. Define the term 'wave'.
9. Distinguish between:
 - (a) Mechanical wave and electromagnetic wave
 - (b) Transverse wave and longitudinal wave.

(c) Compression and rarefaction.

10. The figure below shows a displacement-time graph for a certain wave

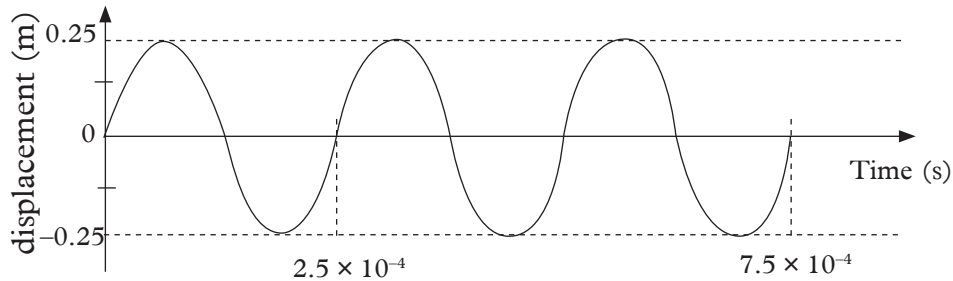

Fig. 7.21: Displacement - time graph

- (a) Identify the type of wave.
- (b) State the period of the wave
- (c) Determine the frequency of the wave.
- (d) If the wave has a wavelength of 3.5 cm, what is its velocity?
11. A wave source generates 300 waves signals in a second. Each of the wave signals has a wavelength of 4.5 cm.
- (a) Determine the:
- Frequency of the wave.
 - Period of the wave.
 - velocity of the wave.
- (b) Determine the time taken by the generated waves to hit a barrier that is 250 m away from the wave.
12. Using specific properties of light, explain why it is a transverse wave.
13. Define the following terms and state its S.I units:
- Amplitude
 - Period
 - Wavelength
 - Frequency
14. Clouds FM broadcasts on a frequency of 88.5 kHz producing signals of wavelength 3389.83 m. Determine:
- (a) The period of its signals

- (b) The velocity of radiowaves
- (c) The velocity of radio free East Africa if its signals have a wavelength of 3405.22 m.
15. (a) Give the meaning of the symbols in the equation $v = f \lambda$.
- (b) Calculate the wavelength of a wave if the speed is 45 m/s and the frequency is 5 Hz.
16. Radio wave travel with a speed of 3×10^8 m/s in air. If a radio station broadcasts at a wavelength 125 m, calculate the frequency of the transmitted waves.

Topic summary

- A **wave** is a periodic disturbance that transfers energy in space from one point to another in a medium.
- When a rope fixed at one end is shaken up and down two waves trains are produced: **transversal** and **longitudinal**.
- In **longitudinal waves**, motion of the medium particles are displaced in the same direction as that of the travel of wave. In the **transversal waves** motion of the medium particles are displaced perpendicular to the direction of the travel of the wave.
- **Wavelength** is the distance between successive crests or troughs of a wave.
- **Amplitude** is the displacement of a particle from its mean or rest position.
- **Period** is the time taken for a wave to make one cycle.
- **Frequency** is the number of waves passing at a given point per second.
- **Compression** is a region in a longitudinal wave with high concentration of vibrating particles.
- **Rarefaction** is a region in a longitudinal wave with low concentration of vibration particles.
- A **pulse** is a single disturbance that moves through a medium from one point to the next point.
- A ripple tank is an apparatus used to demonstrate the various properties of waves like reflection, refraction, diffraction and interference.
- A wavefront is an imaginary line which joins a set of particles which are *in phase* in a wave motion.

- A ray is a line drawn to show the direction of travel of wave energy and is perpendicular to the wavefront.
- Water and sound waves like light waves, obey the laws of reflection.

Topic Test 7

- Two waves that are in phase, they form a type of interference called _____.
A. Constructive **B.** Destructive
C. Coherent **D.** Out of phases
- When a plane wave is reflected, the reflected waves take the shape of the reflecting surface. Draw the reflected waves emerging from a:
(a) Convex reflector
(b) Concave reflector
- Copy and complete this paragraph about waves.
 When a wave enters a shallow region, it _____ down and bends towards the _____. This change of direction is called _____.
- What happens to the following properties of waves after the waves move into shallow water.
(a) Frequency **(c)** Wavefront direction
(b) Speed **(d)** Wavelength
- The figure 7.22 shows a displacement-time graph for a certain wave

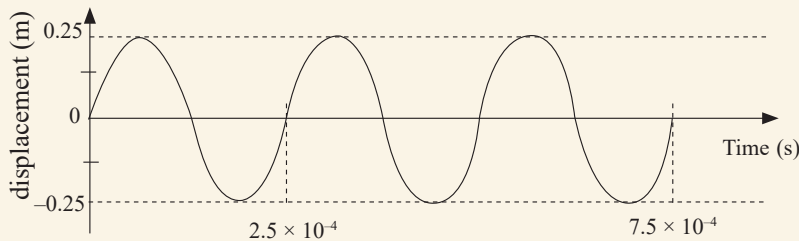

Fig. 7.22: Displacement - time graph

- Identify the type of wave.
 - State the period of the wave.
 - Determine the frequency of the wave.
 - If the wave has a wavelength of 3.5 cm, what is its velocity?
- A wave source generates 300 wave signals in a second. Each of the wave signals has a wavelength of 4.5 cm.
(a) Determine the:
(i) Frequency of the wave.

- (ii) Period of the wave.
(iii) velocity of the wave.
- (b) Determine the time taken by the generated waves to hit a barrier that is 250 m away from the wave.
7. Using specific properties of light, explain why it is a transverse wave.
8. Define the following terms and state its S.I units:
- (a) Amplitude (b) Period
(c) Wavelength (d) Frequency
9. A radio station broadcasts on a frequency of 88.5 kHz producing signals of wavelength 3389.83 m. Determine:
- (a) The period of its signals
(b) The velocity of radiowaves
(c) The velocity of radio Africa if its signals have a wavelength of 3405.22 m broadcasting on the frequency 88.5 kHz.
10. (a) Give the meaning of the symbols in the equation $v = f \lambda$.
(b) Calculate the wavelength of a wave if the speed is 45 m/s and the frequency is 5 Hz.
11. Radio wave travel with a speed of 3×10^8 m/s in air. If a radio station broadcasts at a wavelength 125 m, calculate the frequency of the transmitted waves.

Unit outlines ▶▶▶

- Production of sound waves
- Sources of sound waves
- Nature of sound waves
- Characteristics of sound waves
- Propagation of sound
- Sound pollution

Introduction

In Topic 7, we learnt that sound is an example of longitudinal waves. Since a wave is a form of energy, sound is thus a form of energy propagated in a longitudinal manner. In this topic, we shall study the production, propagation, characteristics and applications of sound waves.

8.1 Production of sound

The following activity will help us understand how sound is produced.

Activity 8.1**To demonstrate sound production**

(Work in groups)

Materials: Metallic string, rubber band, metre rule, drum, piece of wood, glass beaker, pens

Steps

1. Pluck a stretched metallic string or rubber band.
2. Fix one end of a half-metre rule near the edge of one side of a table and press the free end downwards slightly and release it.
3. Blow a whistle or a flute.
4. Hit a metallic rod against another.
5. Hit the 'skin' of a drum gently with a piece of wood.
6. Gently tap a glass beaker with a pen.
7. Why do the objects above produce such noise?
8. How is the noise produced?

In each of the activities within Activity 8.1, sound is produced as the objects vibrate. Sound is a form of wave caused by vibrating bodies.

Fig. 8.1 shows some of the sound producing instruments.



Fig. 8.1: Examples of sound producing instruments

Activities 8.2

To investigate that a vibrating source produces some energy

(Work in groups)

Materials

- A tuning fork
- water in a container
- tooth brush bristle
- A pith ball
- glass plate
- lamp soot

Steps

1. Take a tuning fork and strike hard on a rubber pad with one of the prongs on and observe what happens.
2. Make one of the vibrating prongs of the tuning fork to touch a small pith ball suspended by a thread (Fig. 8.2) and see what happens.
3. What makes the tuning fork vibrate?
4. Dip the vibrating prongs in water in a container and observe what happens.
5. What happens to water immediately the fork is dipped in it?
6. Why does it stop vibrating after sometime?
7. Cover a glass plate with a uniform coating of lamp soot. Attach a short stiff hair of a tooth brush (bristle) to one of the prongs of a tuning fork. Set the tuning fork into vibration and let the bristle lightly touch the soot on the glass plate. Pull the glass plate gently along a straight line and observe what happens (Fig. 8.3).

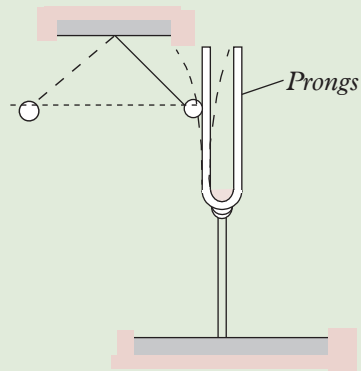

Fig. 8.2: Vibrating tuning fork displaces a pith ball.

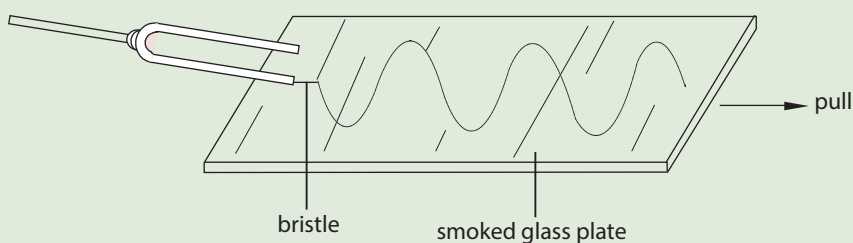

Fig. 8.3: Vibrating tuning fork on a glass plate.

The prongs start vibrating.

The pith ball is seen to be jerked to one side.

Water is violently agitated.

A wavy trace is seen on the glass plate.

The vibrating prongs of the tuning fork produce energy. Therefore, *sound is a form of energy produced by vibrating objects.*

8.2 Sources of sound waves

All sources of sound have some structures which **vibrate**. A guitar has strings, a drum has a stretched skin and the human voice has a vocal cord that vibrate and produce sound. Sound travels through the air to our ears through vibrations enabling us to hear it.

The air (medium of propagation) is necessary as shown by Experiment 1.11. In the experiment, the sound disappeared though the striker can still be seen hitting the gong. Evidently sound cannot travel in a vacuum as light can do. All materials, including solids and liquids and gases transmit sound.

Sound waves produced for example by a loudspeaker consists of a train of compressions and rarefactions (See Fig. 8.4). Hence, sound waves are longitudinal waves.

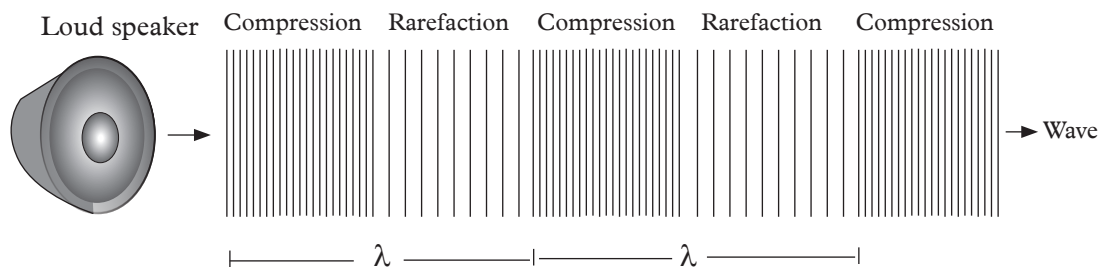

Fig. 8.4: Sound waves as longitudinal waves.

8.3 Nature of sound waves

Consider a tuning fork in a state of vibration as shown in Fig. 8.5. As prong X moves to the right, it compresses the layer of air in contact with it (Fig. 8.5(b)). The compressed layer passes the energy to the next layer of air molecules and returns to the original position. Thus a region of *compressions* moves to the right (Fig. 8.5(c)).

As prong X moves to the left, a region of reduced pressure or a *rarefaction* is produced in the vicinity of (Fig. 8.5(d)). The compressed air in the next layer, moves towards the left to 'equalise' the reduced pressure and hence produces another rarefaction to its right and so on. Thus a region of rarefaction moves to the right.

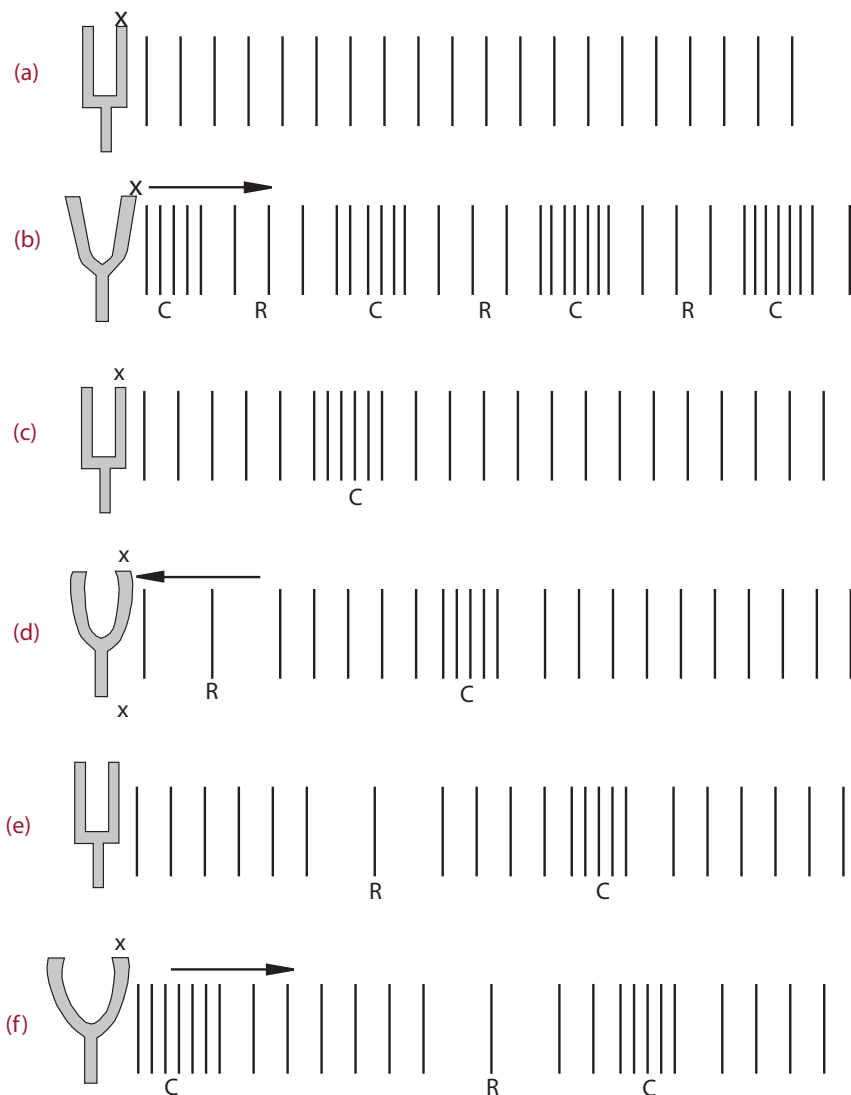

Fig. 8.5: Production of rarefactions and compressions in a sound wave.

Note: As long as the vibrations are periodical, the number of times representing a compression must be equal to the number representing rarefaction and evenly spaced respectively.

Therefore, as the prong X vibrates to and fro, a series of compressions and rarefactions are produced. Each layer of air vibrates back and forth about its *mean* position along the direction in which propagation of energy takes place.

Thus, sound waves are *longitudinal waves*.

The wavelength of sound waves is the distance between two successive compressions and rarefactions.

8.4 The concept of audible range

An **audible range** is a range of frequencies of sound which can be detected by the human ear. Human beings hear only sounds with frequencies from about 20 Hz to 20 000 Hz (20 kHz). These frequencies are the limits of audibility. The upper limit decreases with age.

Sounds with frequencies below 20 Hz are called **infrasonic sounds** while sounds with frequencies above 20 kHz are called **ultrasonic sounds** (ultrasound).

An average human ear can distinguish between two simultaneous sounds if their frequencies differ by at least 7 Hz.

8.4.1 The human ear

Humans and animals detect sound waves using their ears. The human ear converts sound energy to mechanical energy and then to a nerve impulse that is transmitted to the brain. Figure 8.6 shows the parts of a human ear.

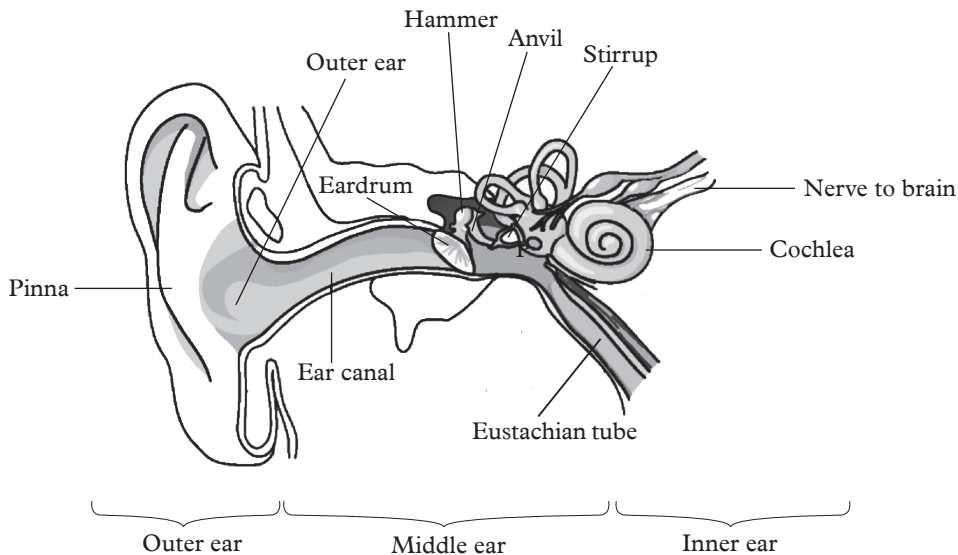

Fig. 8.6: The Human Ear

The human ear has three main sections: the outer ear, middle ear and the inner ear. Sound waves enter the outer ear and travel through the ear canal to the middle ear. The ear canal channels the waves to the eardrum. The eardrum is a thin, sensitive membrane stretched tightly over the entrance of the middle ear. The waves cause the eardrum to vibrate. It passes these vibrations to the hammer which is one of the three bones in the middle ear. The hammer vibrates causing the anvil, the other small bone touching the hammer to vibrate. The anvil passes the vibrations to the stirrup, another small bone touching the anvil. From the anvil, the vibrations pass into the inner ear.

The vibrating stirrup touches a liquid filled sack and the vibrations travel into the cochlea, which is shaped like a shell. Inside the cochlea, there are hundreds of special cells attached to the nerve fibres which transmit the information to the brain. The brain processes the information from the ear enabling us to distinguish the different types of sounds.

8.4.2 Human audible frequency ranges

The compressions and rarefactions produced in air by sound waves reach the eardrum of a person and force the eardrum into similar vibrations. The physical movements of the eardrum are transmitted to the brain and produce a mental sensation of hearing.

The human ear can detect sound waves of frequencies about 20 to 20 000 Hz (cycles per second). We cannot hear the sound waves, if the frequency is less than 20 Hz or is above 20 000 Hz. The upper limit, however varies with persons and age, it is higher in the case of children than in the old people. It is still higher in certain animals like bats.

Just as other types of waves, sound waves obey the wave equation, $v = \lambda f$.

Therefore, the audible frequency ranges is given by;

$$f_{\text{maximum}} = \frac{v}{\lambda_{\text{minimum}}}$$

$$f_{\text{minimum}} = \frac{v}{\lambda_{\text{maximum}}}$$

Example 8.1

A certain animal can hear sound of wavelength in the range of 2 m to 10 m. Calculate its audible range of frequency. Take the speed of sound in air as 330 m/s.

Solution

$$f_{\text{minimum}} = \frac{v}{\lambda_{\text{maximum}}} = \frac{330 \text{ m/s}}{10 \text{ m}} = 33 \text{ Hz}$$

$$f_{\text{maximum}} = \frac{v}{\lambda_{\text{minimum}}} = \frac{330 \text{ m/s}}{2 \text{ m}} = 165 \text{ Hz}$$

Its audible frequency range is 33 Hz to 165 Hz

8.5 Ultrasonic sound

Ultrasonic sound is a sound wave that have a frequency above the normal human audible frequency range. Very high frequency waves can penetrate deep sea-water without loss of energy by diffraction. Examples of sources of ultrasonic sound is ship siren and some factory sirens.

Therefore, ultrasonic sound has a fundamental frequency that is above the human hearing range i.e. sound with fundamental frequency above 20 000 Hz.

The reverse of ultrasonic wave is the infrasonic. Infrasonic is a wave in which the fundamental frequency is lower than the human ear hearing range (audible range).

8.5.1 Uses of ultrasonic sound waves

The following are some of the uses:

1. In medical and surgical diagnosis

Ultrasonic waves are used in place of X-rays during X-radiography scanning parts of the body using an ultrasonic beam. Ultrasonic is also used to sterilize surgical instruments, jewellery and cleaning medicare instruments. Ultrasonic waves are also used to monitor patient's heart beats, kidney, growth of foetus (prenatal scanning) and destroy kidney stones.

2. In industries

Ultrasonic waves is used in cleaning of the machine parts in industries. Objects or parts with dirt are placed in a fluid through which ultrasonic waves are passed. The waves are used in analysing the uniformity and purity of liquids and solid particles.

3. In fishing

Ultrasonic waves are is used to locate shoals of fish in deep sea by the process called *echolocation* i.e. use of echo to locate an object. More interesting is that this method can detect different types of fish. This is because different fish reflect sound to different extents.

4. In security

Ultrasonic waves are used in security systems to detect even the slightest movement. Many buildings have ultrasonic motion sensors that detect motion.

5. *Estimation of distance by bats*: Bats judge the distance away from an object by emitting ultrasound and interpreting the time taken by the reflected wave (echo) to return. The sound they emit is partially or totally reflected from the surface on an obstacle depending on the density of the medium at that point. This helps them to tell where to pass through or perch.
6. *Mapping*: Sound bounces off an object, the shorter the time lapse between the initial sound and the echo, the smaller the distance. It is particularly useful in mapping the depth of the ocean and also finding lost objects at sea.
7. *Ultrasonic* echoes are used to determine the *shape* and *size* of *an object* that is not visible such as sunken ship or a baby in the womb.

Example 8.2

A ship sends out a sound wave and receives an echo after 1 second. If the speed of sound in water is 1 500 m/s, how deep is the water?

Data:

Time taken = 1 s; speed, $v = 1\,500$ m/s for to and fro

Solution

Time taken for sound to reach the seabed = $\frac{t}{2} = \frac{1}{2} = 0.5$ s

$$\text{From; } v = \frac{d}{t} \text{ or use } v = \frac{2d}{\text{total time}}$$

$$d = v \times t = 1\,500 \text{ m/s} \times 0.5 \text{ s} = 750 \text{ m}$$

Exercise 8.1

1. Define the term sound.
2. Describe an experiment to show how sound is produced.
3. Explain the following terms in respect to sound wave:
 - (a) Compression
 - (b) Rarefaction

4. Distinguish between ultrasonic and infrasonic waves.
5. An animal has audible frequency range of 40 Hz to 20 000 Hz. Calculate the corresponding wavelengths of the frequencies.
6. Explain why a human being cannot hear sound above 20 000 Hz.
7. Explain how ultrasonic sound is used in:
 - (a) Industry
 - (b) Security
8. Define:
 - (a) Sound
 - (b) Pitch
 - (c) Echo
 - (d) Reverberation
9. Distinguish between:
 - (a) Infrasonic sound and ultrasonic sound
 - (b) Sound and echo
10. With the aid of a well labelled diagram, describe how the human ear works.
11. A gun is fired and an echo heard at the same place 1.5 seconds later. How far is the barrier which reflected the sound from the gun? (velocity of sound = 330 m/s).
12. State four uses of echo.
13. A policeman standing between two parallel walls fires a gun. He hears an echo after 2.0 seconds and another one after 3.5 seconds. Determine the separation of walls. (Take velocity of sound 340 m/s).
14. Winfred is standing 600 m from a cliff. She bangs two pieces of wood together and hears an echo 3.5 seconds later. Determine the velocity of sound.
15. A spectator watching athletics in a stadium sees the light from the starting gun and hears its sound after 3 seconds. How far is the spectator from the starting point? (Speed of sound in air is 330 m/s)
16. Maryanne is standing between two walls. She is 400 m from the nearest wall. The walls are “y” m apart. Each time she presses a hooter, she hears two echoes one after 2.5 seconds and the second one after 4.5 seconds. Determine:
 - (a) The velocity of sound.
 - (b) The separation distance “y”.

8.6 Characteristics of sound waves

The three main characteristics of musical sounds are:

(a) Pitch

It is the characteristic of a musical sound which enables us to distinguish a sharp note from a hoarse one. For example, the voices of women or children, usually of high pitch than of men. Similarly, the note produced by the buzzing of a bee or the humming of a mosquito is of much higher pitch than the roaring of a lion, though the latter is much louder.

Pitch is purely qualitative and cannot be measured quantitatively. The greater the frequency of a vibrating body, the higher is the pitch of sound produced and vice versa. It should be noted that *pitch is not frequency; it is a characteristic depend on the frequency.* Frequency is a physical quantity and can be measured. Pitch cannot be measured.

The pitch of sound depends on the following two factors:

1. *Frequency of the sound produced*

Pitch is directly proportional to the frequency.

2. *Relative motion between the source and the observer*

When a source of sound is approaching, a listener or the listener approaches the pitch of sound appears to become higher. On the other hand, if the source is moving away from the listener or the listener moves away from the source, the pitch appears to become lower. (This effect is known as the *Doppler's effect*).

(b) Intensity and loudness sound

Intensity of sound at any point is the quantity of energy received per second on a surface area of 1 m^2 placed perpendicular to the direction of propagation at those points. Thus, the intensity of sound is purely a physical quantity, quite independent of the ear and can be measured quantitatively. It is measured in *joules/second/m²*. ($\text{Js}^{-1}\text{m}^{-2}$)

The loudness of sound is the degree of sensation of sound produced in the ear. It depends on the intensity of sound waves producing the sound and the response of the ear. In general, *the sound waves of higher intensity are louder.*

Intensity of sound depends on the following factors:

1. *Amplitude of vibrating body*

The intensity or loudness I , of sound is directly proportional to the square of the amplitude of the vibrating body.

If the amplitude of the vibrating body is doubled, the loudness of sound produced becomes two times greater.

2. *Distance from the vibrating body*

The intensity or loudness of sound I , is inversely proportional to the square of the distance from the vibrating body.

$$\therefore \text{Intensity} \propto \frac{1}{(\text{distance})^2}$$

If the distance from the source of sound is doubled, its intensity of sound becomes $\frac{1}{4}$ and so on.

3. *Surface Area of the vibrating surface*

Intensity is directly proportional to surface area of the vibrating body. This is because the greater the area of the vibrating surface, the larger the energy transmitted to the medium and the greater is the loudness of the sound produced.

4. *Density of the medium*

The intensity of sound is directly proportional to the density of the vibrating medium

For example, an electric bell ringing in a jar filled with oxygen produces a much louder sound than the jar filled with hydrogen. Similarly, the intensity sound of a tuning fork is much higher when the stem of the fork is placed on the table than in air.

5. *Motion of the medium*

If wind blows in the direction in which the sound is travelling, the intensity of sound at a point in the direction of the wind increases and vice versa. Thus, if we shout on a windy day, the sound heard is much louder at a certain distance in the direction of the wind than at the same distance in the opposite direction.

(c) **Quality (Timbre) of sound**

Quality is that characteristic of musical note which enables us to distinguish a note produced by one instrument from another one of the same pitch and intensity produced by a different instrument. If, for example, a note of a given pitch is successfully produced by a violin, a guitar or a piano, the ear can distinguish between the three notes.

For example, Fig. 8.7 represents two separate waves, one of which has the frequency twice that of the other. When the resultant of these two waves fall upon the ear, the ear is able to recognise the individual waves which have given rise to the resultant wave as they have different qualities (timbre).

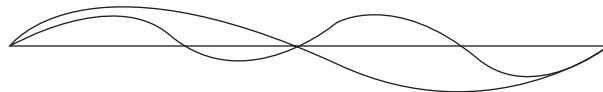

Fig. 8.7: Waves of two different frequencies

Musical sounds and noises

In general, sound may be roughly classified as either (a) musical sounds (b) noises. If we pluck the string of a guitar or a stretched sonometer wire or set a tuning fork into vibrations, the sound produced has a pleasant effect on our ears. If however, we listen to the slamming of a door, the sound produced by thunder clouds or the rattling sound of some parts of a car, the sounds produced have an unpleasant effect on the ears. A sound of *which appears pleasant to the ear is called a musical sound* whereas that *which produces an unpleasant or jarring effect on the ear is called a noise*.

The curves shown in Fig. 8.8 (a) and (b) bring out the difference between noises and musical sounds.

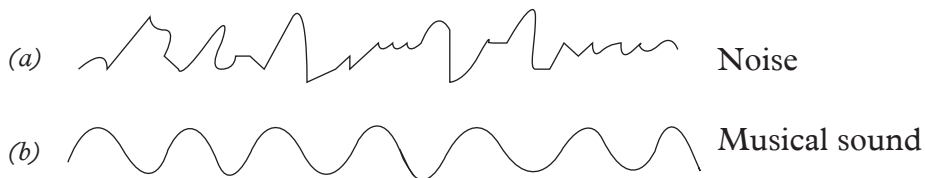

Fig. 8.8: Noise and musical sound

Musical sound is *regular and periodic* with pulses following each other very rapidly producing the sensation of a continuous sound. Noises, on the other hand, are generally *sudden* and have no regular period; and are usually complex in nature.

8.7 Propagation of sound

Sound waves cannot be transmitted through a vacuum. The transmission of sound waves requires at least a medium which can be a solid, liquid or a gas.

Activity 8.3

To show that sound requires material medium to travel through

(Work in groups)

Materials

- Air tight bell jar
- Electric bell
- Power supply (battery) and connecting wire
- Vacuum pump

Steps

1. Suspend the electric bell inside an air-tight bell jar as shown in the Fig. 8.9.

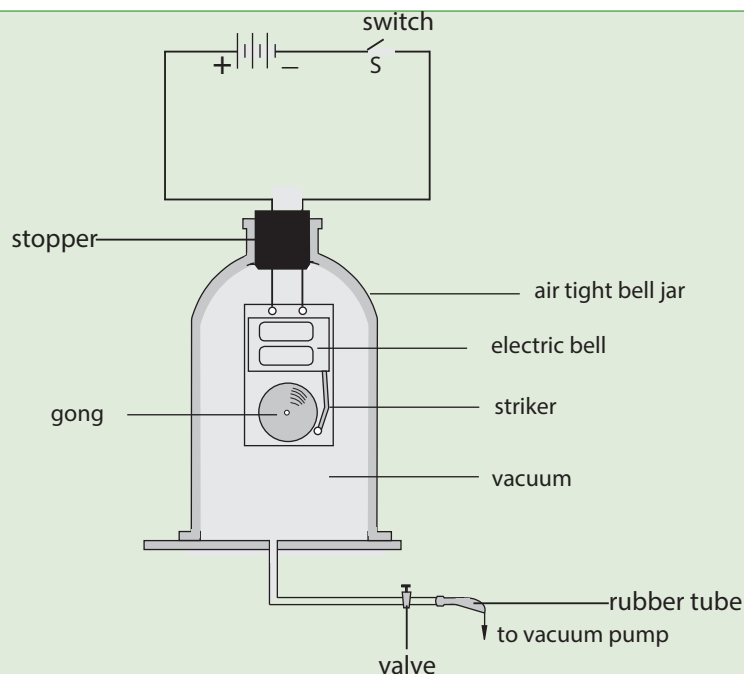

Fig. 8.9: Electric bell

2. Switch on the bell, while there is some air in the bell jar.
3. Start the pump to take the air molecules out of the jar as you listen to the change in the intensity of sound.
4. Return the air to the bell-jar again by opening the stopper slightly as you listen the change in sound.
5. How does the bell produce sound?

When there is air in the jar the bell is heard ringing.

When the pump is switched on to remove the air, the sound dies down gradually and is eventually not heard at all.

When air is allowed to return to the jar, the sound is heard once again.

This experiment shows that a medium like air is necessary for propagation of sound. *Sound cannot travel through a vacuum.*

8.8 Speed of sound in solids, liquids and gases

The speed of sound is different in solids, liquids and gases. The arrangement of particles in matter determines how fast sound can travel in matter. The following experiment will help us illustrate that sound require material media to travel.

Activity 8.4

To design and investigate the speed of sound in solids and fluids

(Work in groups)

Materials

- A metal spoon
- A tuning fork

Steps

1. Tie a metal spoon or a light tuning fork to one end of a string and hold the other end near the ear, by not touching it.
2. Let someone touch the spoon with a finger or the set prongs of the fork into vibration by gently hitting the prongs with a rubber. Listen to the sound produced.
3. Remember to repeat the experiment with the free end of the string in contact with the ear. Compare the loudness of sound heard in both cases. Which sound is louder?
4. Write a report about the speed of sound in solids, liquids and gases. Present your findings in a classroom discussion.

The loudness of sound heard is more when the string is in contact with the ear. The string transmits sound through it and does it better than air.

This experiment shows that sound can travel through solids. Similarly if sound is produced inside water e.g in a swimming pool, it can be heard a short distance away.

From the experiments, it has been established that the speed of sound in water is about 1 500 m/s and in steel about 5 500 m/s.

Comparison of the speed of sound in solids, liquids and gases

The speed of sound varies in solids, liquids and gases. Activity 8.5 will help us to show the speed of sound in solids, liquids and gases.

Activity 8.5

Comparing speed of sound in solids and gases

(Work in groups)

Materials

Wooden plank

Steps

1. Let one learner place the ear on one end of 20 m wooden plank, while another taps the plank once with a stone on the opposite end. What do you hear?
2. Which sound is heard faster and why do you think this is?

In Activity 8.5, two sounds, will be heard by the listener: one coming through the wooden plank followed by another through the air. This shows that sound travels faster in solids than in air.

Several experiments proved that

- The speed of sound is higher in liquids than in gases and slower than in solids.
- The speed of sound is faster in solids than in liquids because the particles or atoms in solids are closely packed. This makes it easier for particles to transmit sound from one point to another.
- The speed of sound in liquids is faster than in gases because the particles in liquids are relatively closer than those in gases.
- Therefore the speed of sound is slowest in gases.

Lightning and thunder

About the middle of the 18th Century, an American Scientist Benjamin Franklin demonstrated that charged thunder clouds in the atmosphere produce thunderstorms. These thunderstorms produce a lot of sound which we hear as *thunder* on the earth. Due to the spark discharge occurring between two charged clouds or between a cloud and the earth, electric spark discharge, called the *lightning* occurs. Though the sound due to thunder is produced first, we see the flash of lightning first and after a few seconds we hear the sound of thunder. This is due to the fact that light travels much faster than sound in air. Experiments have proved that the speed of light in air (or vacuum) is 3.0×10^8 m/s.

Take care!

Avoid walking in drain water or standing under tall trees when it is raining.

Example 8.3

The time interval between “seeing” the flash of lightning and “hearing” the sound of thunder clouds is 5 seconds.

- (a) Calculate the distance between the thunder clouds and the observer on the earth.
- (b) Explain why the calculated distance is only approximate. (Speed of sound in air = 330 m/s)

Solution

(a) speed of sound = $\frac{\text{distance}}{\text{time}}$

$$v = \frac{x}{t}$$

$$x = v \times t = 330 \times 5 = 1\,650 \text{ m/s}$$

∴ The distance between the thunder clouds and the observer is 1 650 m.

(b) The clouds may be moving.

8.8.1 Factors affecting the speed of sound in gases

(a) Density

The higher the density of a gas, the higher the speed of sound. For example, the density of oxygen is 16 times higher than the density of hydrogen hence sound travels faster in hydrogen than in oxygen (speed of sound in hydrogen = 4 × speed of sound in oxygen).

(b) Humidity

Moist air containing water vapour is less dense than dry air. The density of water vapour is about 0.6 times that of dry air under the same temperature conditions. If the humidity of air increases, density of air decreases hence the speed of sound in air increases.

Early in the morning the percentage of humidity of air is more and sound travels faster in the morning air.

(c) Pressure

The speed of sound is not affected by any change in pressure provided temperature is constant. For example, on a day when the temperature and humidity of air is the same in Lilongwe and a city at the sea level, the speed of sound is the same in the two cities, although the air pressure in Lilongwe is lower than that at the city situated at the sea level.

(d) Temperature

A change in the temperature of a gas changes its density and hence affects the speed of sound through it. If temperature increases, the density of air decreases and hence the speed of sound increases. If temperature decreases the reverse is the effect.

(e) Wind

Wind “drifts” air through which the sound waves travel. If air blows in the direction of sound, then the speed of sound increases. The speed of wind is added to the speed of sound in air, to get the resultant speed of sound. If wind blows in the opposite direction to that of sound, then the sound travels more slowly.

Table 8.1 summarises how the speed of sound in matter is related and their corresponding reasons.

Table 8.1

Matter	Speed of sound	Reason
Solid	Fastest	Particles are closely packed
Liquid	Medium	Particles loosely packed
Gas	Slowest	Particles are very far apart

Exercise 8.2

1. Explain why the speed of sound in solids is faster than the speed of sound in air.
2. Name two factors that affect the speed of sound in air.
3. State the characteristics of sound waves.
4. Explain why at night sound from a source is clear than during hot daytime.
5. Describe two factors that affect the pitch of sound.
6. Define the following terms:
 - (a) Resonance
 - (b) Quality
7. Distinguish between music and noise.
8. Explain the factors that affect the frequency of sound.
9. During thunder and lightening, there are two types of waves produced.
 - (a) Name the two waves.
 - (b) Which one reaches the ground first? Explain.
10. Sound is a longitudinal wave. How is it propagated? Describe an experiment to demonstrate the fact that sound is actually produced by vibrating body.

8.9 Reflection of sound waves

Just like light, sound waves undergo reflection on striking plane hard surface as well as curved surfaces.

Activity 8.6

To investigate the laws of reflection of sound waves

(Work in groups)

Materials

- Two tubes A and B
- Flat piece of metal
- Hard drawing board
- Stopwatch

Steps

1. Set up two tubes A and B, about 1.2 m long and 4 or 5 cm in diameter as shown in Fig. 8.10. Place a flat piece of a large metal or a hard drawing board facing the tubes about 10 cm from their ends.
2. Place a stop watch at the mouth of the tube A and place your ear at the end of the tube B. A soft board S is placed in between the two tubes to prevent the sound waves from the stop watch to reach the ear directly.

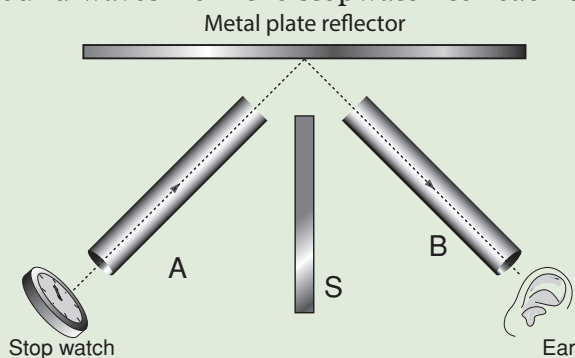

Fig. 8.10: Reflection of sound waves

3. Adjust the position of tube B until the sound heard is the loudest.
4. Measure angles of incidence i and reflection r . What do you notice? Explain.
5. Are the angles the same?
6. Is the sound heard same as the one from the source?
7. What property do the sound obey from the above observations?

These angles are found to be approximately equal. Both the tubes containing the incidence waves and the reflected waves lie in the same plane as the normal to the reflecting surface. We can then conclude that *sound waves obey the laws of reflection as is the case with light wave*.

You should note that since audible sounds have large wavelengths, you need a reasonably large reflector.

When sound waves meet a boundary between one medium and another, a part of it is *reflected*, a part is *refracted* and the remaining part is *absorbed*. The relative amounts of these parts are determined by the size and the nature of the boundary under consideration. The proportion of energy reflected is greater in the case of hard substances such as stone and metal. An *echo*, a reflection of sound, is

frequently heard in mountainous regions. There is very little reflection from cloth, wool and foam rubber. Sound which is incident on such soft materials is mainly transmitted through them or absorbed. In places where the effect of echo has to be illuminated, e.g. musical recording room and concert halls, soft materials are used to line the walls of the hall.

Also the ear is a sound reflector, reflecting sound waves down the ear canal to the ear drum.

Uses of reflection of sound

1. Sound waves can be used to measure the speed of sound in air by reflecting sound at hard surfaces.
2. In public halls and churches, parabolic sound reflection is often placed behind the speaker. It reflects the sound waves back to the audience and thus increasing the loudness of the sound.
3. Sound waves undergo a total internal reflection just like light. Speaking metal tubes that are used to pass message on ships (Fig. 8.11) use total internal reflection of sound waves.

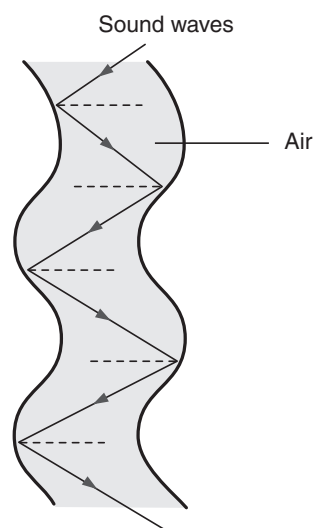

Fig. 8.11: 'Speaking' metal tubes

Determining speed of sound by echo method

Activity 8.7

To determine speed of an echo sound

(Work in groups)

1. Stand about 100 m away from a cliff or a large hard surface such as the wall of a building and clap your hands. What do you hear?
2. How can you determine the speed of the sound you hear?

In Activity 8.7, you will hear two sounds; the one you produce and the reflected sound.

The reflected sound produced is called an *echo*. An echo is a reflection of sound from a large hard surface.

Activity 8.8

To investigate how echo sound is produced

(Work in groups)

Steps

1. Stand about 100 m from an isolated, large hard surface or a stone wall.
2. Shout loudly and start a stopwatch at the same time. Stop the watch on hearing the echo. Find the time interval between the production of the loud noise and hearing the echo. Are you able to time the echo accurately?
3. Repeat this a number of times and find the average time taken.
4. How can you increase the accuracy of this experiment?

Note

For activities above to be more accurate:

1. A large obstacle, e.g. a cliff or a wall is needed. This is because the wavelength of sound waves is large.
2. A minimum distance between the source and the reflecting surface is required. This minimum distance, called **persistence** of hearing is about **17 m**.

In Activity 8.8, you should have noticed that an echo is heard after some time interval. During this time, the sound travels to and from the hard surface covering twice the distance.

The speed of sound in air is given by the formula:

$$\text{Speed} = \frac{\text{Total distance travelled by sound}}{\text{Total time taken}}$$

Here are typical results from Activity 8.8:

Distance from the wall is d , metres.

Average time interval between the production of sound and hearing its echo is t seconds.

Total distance travelled by sound is $2d$ metres.

$$\text{Speed of sound} = \frac{\text{Total distance travelled}}{\text{Total time taken}}$$

$$v = \frac{2 \times d \text{ (m)}}{t \text{ (s)}}$$

$$\therefore \text{The speed of sound in air is given by } v = \frac{2d}{t}$$

Example 8.4

A girl standing 100 m from a tall wall and bangs two pieces of wood once. If it takes 0.606 s for the girl to hear the echo, calculate the speed of sound in air.

Solution

$$\begin{aligned}\text{Speed of sound, } v &= \frac{\text{Total distance}}{\text{Total time taken}} = \frac{2d}{t} \\ &= \frac{2 \times 100}{0.606} = \frac{200}{0.606} \\ &= 330 \text{ m/s}\end{aligned}$$

\therefore the speed of sound in air is 330 m/s

Example 8.5

A man stands in front of a cliff and makes a loud sound. He hears the echo after 1.2 s. If the speed of sound in air is 330 m/s, calculate the distance between the man and the cliff.

Solution

Let the distance between the man and the cliff be x . (Fig. 8.12)

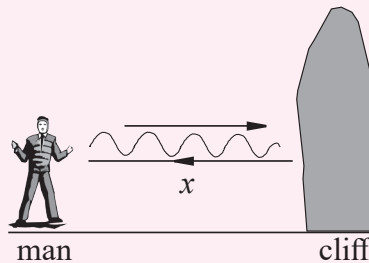

Fig. 8.12.

$$\begin{aligned}\text{Speed of sound} &= \frac{\text{Total distance}}{\text{Total time}} \\ 330 \text{ m/s} &= \frac{2x}{1.2} \\ 2x &= 330 \times 1.2 \\ &= 396 \text{ m} \\ \therefore x &= 198 \text{ m}\end{aligned}$$

The distance between the man and the cliff is 198 m.

Example 8.6

A man standing between two parallel cliffs fires a gun. He hears the first echo after 1.5 s and second echo after 2.5 s.

(a) What is the distance between the cliffs?

(b) When does he hear the third echo? (Take speed of sound in air to be 336 m/s).

Solution

(a) The sketch is as shown in Fig. 8.13.

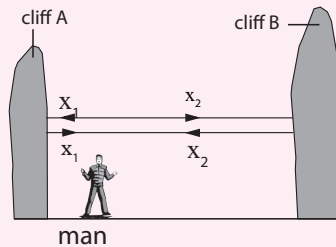

Fig. 8.13: A man between parallel cliffs

From Cliff A:

$$\text{Speed, } v, = \frac{\text{Total distance travelled}}{\text{Total time taken}}$$

$$v = \frac{2x_1}{1.5} \Rightarrow 2x_1 = 1.5 \times v$$

$$\therefore 2x_1 = 1.5 \times 336$$

$$x_1 = 252 \text{ m}$$

From cliff B:

$$v = \frac{2x_2}{2.5} \Rightarrow 2x_2 = 2.5 \times v$$

$$\therefore 2x_2 = 2.5 \times 336 = 840$$

$$x_2 = 420 \text{ m}$$

\therefore The distance between the cliffs is $252 \text{ m} + 420 \text{ m} = 672 \text{ m}$

(b) The first echo (after 1.5 s) reaches cliff B and returns after 2.5 s. So the man hears the 3rd echo after $1.5 + 2.5 = 4 \text{ s}$.

Exercise 8.3

1. How is sound propagated?
2. Define the term echo.
3. A person stands in front of a wall and makes a loud sound. She hears the echo after 1.55s. If the speed of sound is 333 m/s. Calculate the distance between the person and the cliff.

4. A person standing 80 m from the foot of a cliff claps and hears an echo after 0.9 s. What is the speed of sound in air?
5. A pupil, standing between two cliffs and 500 m from the nearest cliff clapped his hand, and heard the first echo after 3 s and the second echo 2 s later. Calculate:
 - (a) The speed of sound in air,
 - (b) The distance between the cliffs.
6. An echo of the sound produced by a whistle is heard after 0.50 s. If the speed of sound in air is 332 m/s, find the distance between the whistle and the reflecting surface.

8.10 Sound pollution

Sound is a very important form of energy. Human beings and animals use sound as a way of communication. But if sound is unorganised, it becomes *noise*. Any unwanted sound becomes a nuisance and leads to *pollution in form of noise*. Therefore, *sound pollution is a type of pollution caused by undesirable or unwanted sound*. Sound pollution can cause damages to eardrum or hinder communication. Sources of sound pollution are: very high music from discos, concerts, celebrations, factory sirens, traffic noise, aircrafts, alarms and others.

Everybody is encouraged to minimize sound pollution at all cost. The government through some agencies must prohibit sound pollution by enacting some laws to govern this. The following are some of the ways used to minimize sound pollution.

1. Factories are encouraged to use sound sirens that are environmental friendly. Most of them use the normal fire alarms.
2. During construction of musical concert halls, the constructor should use materials that absorb most of incident waves of sound to avoid reverberation (reflected multiple sound).
3. Proper laws must be enacted by the government to reduce sound pollution.
4. Proper education of the citizens on sound pollution should be done to sensitize them on the important of reducing sound pollution.



*Listen to moderate music!
Loud music can affect your eardrum if you listen for long.*

Exercise 8.4

1. Explain what is sound pollution?
2. Sound wave just like light wave undergo reflection. Explain two uses of reflection of sound.
3. Explain two ways in reducing sound pollution.

Topic summary

- All vibrating bodies produce sound.
- Sound cannot travel through a vacuum. It needs a material medium like solid, liquid or gas.
- Sound waves are longitudinal in nature consisting of compressions and rarefactions.
- Human audible frequency range is between 20 Hz and 20 000 Hz.
- Speed of sound in air = 332 m/s at 0°C.
- Speed of light in vacuum = 3×10^8 m/s.
- Sound waves undergo reflection. **Reflection** is the bouncing back of sound wave when it strikes plan hard surface or curved surface.
- Echo is the reflection of sound from a large, rigid barrier like cliff, tall wall etc.
- Speed of sound in air can be determined by echo method.
- Density of air, humidity, temperature and wind affect the speed of sound.
- Pressure, amplitude of wave and loudness of sound do not affect the speed of sound.
- **Ultrasonic wave** is a sound wave that have a fundamental frequency above the human audible range frequencies.
- A sound which appears pleasant to the ear is called a **musical sound** and the one which produces a jarring effect on the ear is called **noise**.

Unit Test 8

1. Sound cannot pass through a
 - A. solid
 - B. liquid
 - C. air
 - D. vacuum
2. A normal human being can hear sound of frequency
 - A. less than 20 Hz.
 - B. between 20 Hz and 20 000 Hz.
 - C. between 20 Hz and 200 Hz.
 - D. above 20 000 Hz.
3. Which of the following is correct? Sound waves
 - A. are transverse in nature.
 - B. are longitudinal in nature.
 - C. can never undergo diffraction.
 - D. can never interfere with each other.
4. The speed of sound is NOT affected by
 - A. pressure
 - B. humidity.
 - C. temperature
 - D. wind.
5. Which statement is true about the music produced by the loudspeaker of a radio? When the music is made louder,
 - A. the amplitude of sound decreases.
 - B. the amplitude of sound increases.
 - C. the speed of sound increases.
 - D. the speed of sound decreases.
6. Suggest a simple experiment to establish each of the following:
 - (a) Sound is produced by a vibrating body.
 - (b) Sound cannot travel through vacuum.
7. State three factors which affect the speed of sound in air. Choose one of the factors and explain how it affects the speed of sound in air.
8. In which gas is the speed of sound greater, hydrogen or oxygen?
9. (a) Describe an experiment to show how echoes are produced.
 - (b) The echo method can be used to determine the speed of sound in air.
 - (i) What measurements would you take in order to do this?
 - (ii) Show how you would calculate the speed of sound in air from your measurements.

- (iii) State a precaution to be taken to improve your result.
10. A person standing 80 m from the foot of a cliff claps and hears an echo after 0.9 s. What is the speed of sound in air?
11. A student, standing between two cliffs and 500 m from the nearest cliff clapped his hand, and heard the first echo after 3 s and the second echo 2 s later. Calculate:
- The speed of sound in air.
 - The distance between the cliffs.
12. A worker uses a hammer to knock a pole into the ground (Fig. 8.14).

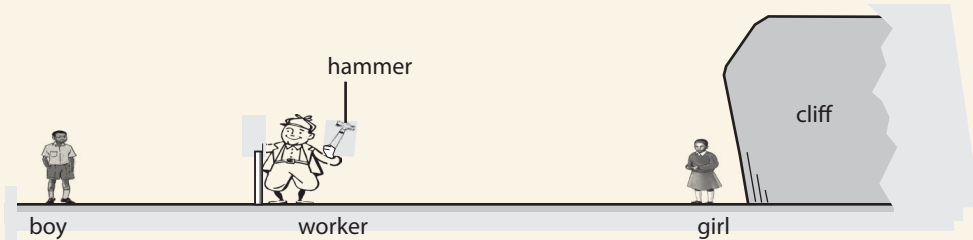

Fig. 8.14: A worker knocking hammer against the pole

- A girl at the foot of the cliff hears the sound of the hammer after 2.0 s. Calculate the distance of the worker from the girl (speed of sound in air is 340 m/s)
 - A boy on the other side of the cliff observes that each time the hammer hits the pole, he hears two separate sounds, one after the other. Explain this observation. Given that the first sound is heard by the boy after 1.0 s, determine the:
 - Distance of the boy from the worker.
 - Time interval between the two sounds.
13. A soldier standing between 2 cliffs fires a gun. She hears the first echo after 2 s and the next after 5 s.
- What is the distance between the two cliffs?
 - When does she hear the third echo? (speed of sound in air = 336 m/s).
 - Why is the 3rd echo faint than the 2nd one?
14. A student makes observations of a distant thunderstorm and finds the time interval between seeing the lightning flash and hearing the thunder as 4.0 s. Given the speed of sound in air = 340 m/s and speed of light in air = 3.0×10^8 m/s,

- (a) Explain why there is a time delay?
 - (b) Calculate the distance between the thunder cloud and the student.
 - (c) Explain why the speed of light is not taken into account in this calculation.
 - (d) Calculate the frequency of the flash of light emitted if the mean wavelength of light emitted is 6.0×10^{-7} m.
15. In an athletics competition, the time keeper in a 100 m race starts the stopwatch on hearing the sound from the starter's pistol and records the time as 10.00 s. Calculate:
- (a) The actual time taken by the athlete to cover the 100 m race.
 - (b) The average speed of the athlete.
(speed of sound in air = 340 m/s).

Topics in the unit

Topic 9: Heat Transfer

Learning outcomes**Knowledge and Understanding**

- Understand the nature of heat
- and describe its effects on matter

Skills

- Design tests to show the factors affecting heat transfer, distinguish between conduction and radiation of heat, and between good and bad conductors of heat.
- Observing carefully.
- Predict expectations.
- Use appropriate measures.
- Collect and present results appropriate in writing.
- Interpret results accurately.
- Report findings appropriately
- Explain applications of heat transfer.

Attitudes

- Appreciate the application of modes of heat transfer.

Key inquiry questions

- Why is heat important?
- How can heat be produced?
- Why is that the expansion of material a nuisance?
- Why that a rough surface is a better emitter of radiation than a polished surface?
- Why that a dull black surface is a better absorber of heat than a polish one?

Unit Outline ▶▶▶

- Heat and temperature
- Heat transfer by conduction
- Heat transfer by convection
- Heat transfer by radiation
- Applications of heat transfer
- Linear expansion

Introduction

In our environment, most interactions between systems involve transfer of heat from one system to another. For example, when we bask in the sun, we feel warmer, when we touch a hot sauce pan, we feel the heat.

In this unit, we will discuss the different modes of heat transfer through which heat is transferred from one region to another. We will begin by reviewing the difference between heat and temperature.

9.1 Heat and temperature

The following activity will enable us to understand the difference between heat and temperature.

Activity 9.1

To investigate the difference between heat and temperature

(Work in groups)

Steps

1. In secondary 1, we learnt about heat and temperature. What is the difference between heat and temperature?
2. With the help of your teacher, recall and conduct an experiment to differentiate between heat and temperature.
3. Record the observation. Draw conclusions and explain your findings in a group and class discussion.

Heat is a form of energy that flows from a hot to a cold body while temperature is the degree of hotness or coldness of a substance.

9.2 Methods of heat transfer

Activity 9.2

To describe the methods of heat transfer

(Work in pairs or in groups)

Fig 9.1 below shows a person heating some liquid in saucepan over fire.

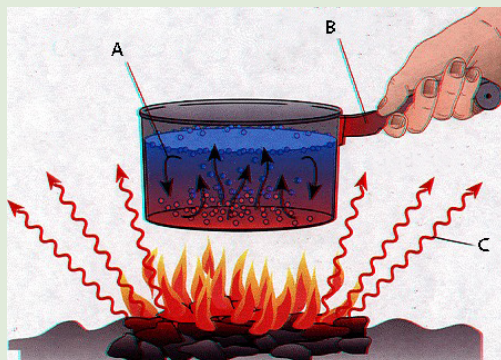

Fig. 9.1: Heating some liquid in a saucepan

1. Identify the modes of heat transfer marked A, B and C.
2. Discuss how each of the modes of heat transfer takes place, citing the states of matter through which the processes take place.
3. Describe one application of each type of the above modes of heat transfer in real life.
4. Present your findings to the rest of the class in a class discussion.

There are three modes of heat transfer: **conduction**, **convection** and **radiation**. Conduction of heat is through solids, convection in fluids and radiation in gases.

9.2.1 Heat transfer by conduction

9.2.1.1 Demonstration of conduction of heat

The following experiment will illustrate conduction of heat in solids.

Activity 9.3

To design and investigate heat transfer in solids

(Work in groups)

Materials:

- A metal spoon
- A beaker full of boiling water
- Bunsen burner
- Wax

Instructions

1. This activity involves an investigation. You are required to set-up the apparatus as shown in Fig. 9.2 below. Come up with a procedure and execute it to investigate the heat transfer in solids.
2. With the help of your teacher carry out the investigation. Write a report and discuss your findings in a class presentation.
3. How can the investigations be improved?
4. Besides the materials provided which other locally available materials that can be used to carry out the investigation?

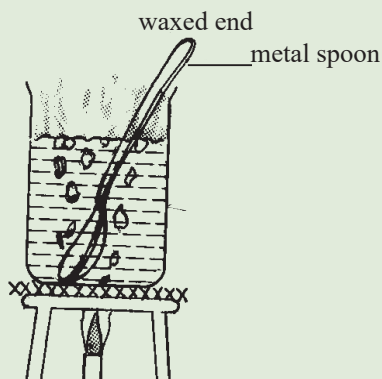

Fig. 9.2: A spoon inside boiling water

5. Why do you think the free end of the spoon gets hot after sometime? Explain.

Solids transfer heat from one point to another. For instance, the free end of the spoon outside the beaker in Fig. 9.2 becomes hot. Heat energy is transferred from the inside to the outside through the metal spoon i.e. from a region of *higher temperature* to a region of *lower temperature*.

This process of transfer of heat energy in solids is called *conduction*. Conduction is the transfer of heat from one substance to another that is in direct contact with it. In conduction there is no visible movement of the heated particles.

9.2.1.2 Mechanism of conduction of heat

We have already learnt that when temperature increases, the molecules have larger vibrations. This knowledge can help us understand the mechanism of conduction of heat. When the molecules at one end of a solid receive heat energy from the heat supply, they begin to vibrate vigorously. These molecules collide against the neighbouring molecules and agitate them. The agitated molecules, in turn, agitate the molecules in the next layer and so on till the molecules at the other end of the solid are agitated. Thus, the heat is passed from one point to another till the other end becomes hot. Hence, in *conduction*, energy transfer takes place by vibration of the molecules. There is no actual movement of the heated particles.

Activity 9.4

To demonstrate that heat energy flows due to a temperature difference

(Work in groups)

Materials:

- An iron bar about a metre long with holes drilled at equal intervals
- Wax
- Water bath
- Drawing pins
- Stand/clamp
- A bunsen burner

Steps

1. Fill the holes of the iron bar partially with wax and insert the drawing pins into them.
2. At one end of the bar put a wooden screen and insert it in a water bath. Heat the end points slowly and gradually (Fig. 9.3).

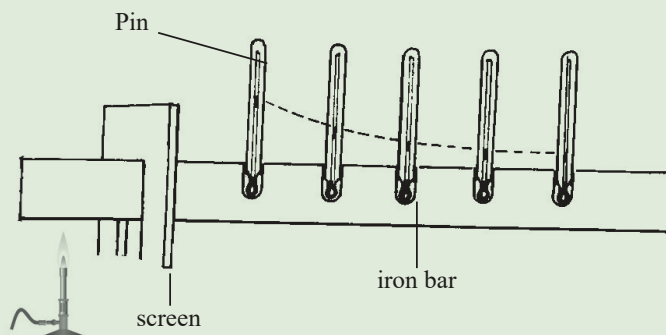

Fig. 9.3: The higher the temperature difference the higher the energy transferred

4. After some time, note the temperature readings of the pins. Are the drawing pins falling at the same time? Why do you think that is so?

The pin nearest to the bunsen burner registers the highest rise in temperature, and the one farthest away registers the least temperature rise.

When one end of the rod was inserted into boiling water, a large temperature difference is set up between the two ends and heat energy flowed from the region of higher temperature to that of lower temperature. Hence heat energy flows due to *temperature difference* and the pins fall slowly.

If the activity is repeated by replacing the hot water bath with a bunsen burner flame (temperature of the bluish part of the flame is about 900°C), the rise in temperature registered by each pin is higher. Hence the higher the temperature difference, the higher the energy transfer and the pins fall this time faster.

Heat energy flows in solids is due to temperature difference. The higher the temperature difference, the higher the energy flow.

9.2.1.3 Comparing rates of conduction in metals

Activity 9.5

To show that heat transfer in solids depends on the material

(Work in groups)

Materials

- A copper rod
- Iron rod
- Aluminium rod
- 3 match sticks
- Wax
- Tripod stand
- A bunsen burner

Steps

1. Take three rods, copper, aluminium and iron of the same length and thickness. Fix a matchstick (or a light metal pin) to one end of each rod using a little melted wax.
2. Place the rods on a tripod stand and heat the free ends with a burner as shown in Fig. 9.4. Observe what happens.

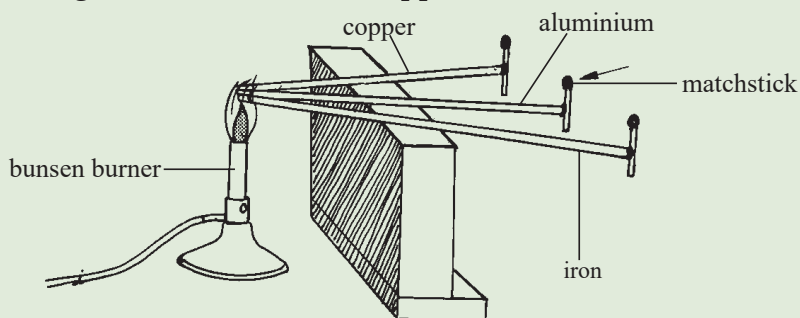

Fig. 9.4: Comparing heat transfer through different conductors

3. Which rod falls first? Which one falls last?
4. Why do you think they did not fall all of them at the same time?

The matchstick falls off from the copper rod first then aluminium and finally from the iron rod.

When the temperatures of the other ends of the rods reach the melting point of wax, the matchstick falls off. The matchsticks do not fall off at the same time, because the energy transferred is not equal for all the rods. The matchstick from the copper rod is the first one to fall off showing that of the three metals, copper is the best conductor of heat followed by aluminium and then iron.

Good conductors and poor conductors of heat

A material or substance which has the ability to transfer heat through itself is called a **good conductor**. Most metals are good conductors of heat e.g copper etc.

Substances like water, air, glass, wood, plastic, paper, etc which have a poor ability to transfer heat are called **poor conductors** of heat.

Poor conductors of heat are sometimes referred to as **insulators**.

9.2.2 Heat transfer by convection

9.2.2.1 Convection in liquids

Activity 9.6

To observe convection current in water

(Work in groups)

Materials

- A long straw
- A crystal of potassium permanganate
- A beaker containing water
- A bunsen burner

Steps

1. With the help of a long straw, drop a small crystal of potassium permanganate to the right side of the bottom of a flask or a beaker containing water. What do you observe?
2. Heat the flask gently at the right side of the flask (Fig. 9.5). Observe what happens.

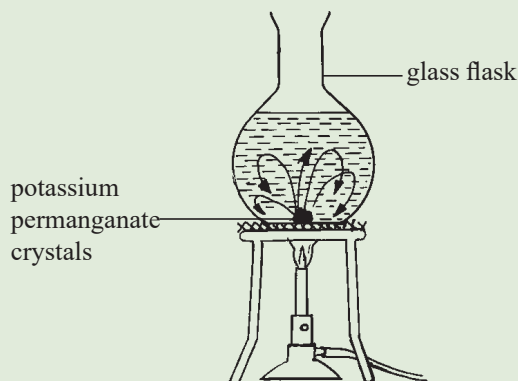

Fig. 9.5: Convection currents in water

3. What do you observe in the beaker when you continuously heat the water? Explain your observations.
4. Why do you think the potassium permanganate crystals behave in such manner?

Coloured streaks are observed to rise from the bottom to the top.

The crystal dissolves and the hot water of less density starts rising displacing the cold dense water down. The streams of physically moving warm liquid are called *convection currents*.

Heat energy is transferred by the convection currents in the liquid. The transfer of heat by this current is called *convection*.

9.2.2.2 Convection in gases

Activity 9.7

To investigate convection current in air

(Work in groups)

Materials

- A box with a glass window, and two chimneys
- A candle
- Smouldering pieces of wick

Steps

1. Take a box with a glass window and two chimneys fixed at the top.
2. Place a lighted candle under one chimney and hold a smouldering piece of wick above the other chimney as shown in Fig. 9.6. What do you observe?
3. Why do you think the smouldering pieces of wick behave in such manner after heating them?

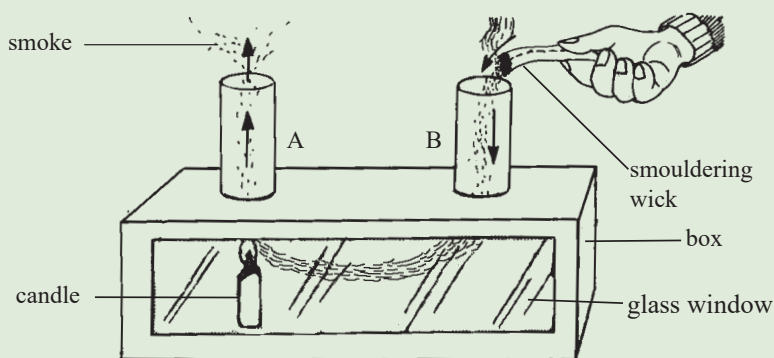

Fig. 9.6: Convection currents in air.

Smoke from the smoldering wick is seen to move down through chimney B then to the candle flame and finally comes out through chimney A.

Air above the candle flame becomes warm and its density decreases. Warm air rises up through chimney A and the cold dense air above chimney B is drawn

down this chimney and passes through the box and up the chimney A. The smoke particles from the wick enable us to see path of convection current (Fig. 9.7).

Heat is transferred in air through convection currents. This convection current passes energy as shown in Activity 9.8.

Activity 9.8

To illustrate that convection currents possess energy

(Work in groups)

Materials:

- A thin circular disk
- A card board
- A candle flame

Steps

1. Take a thin circular disk of tin or cardboard and cut out six blades all round (Fig. 9.7(a)). Pivot the disk on a bent needle (Fig. 9.7(b)).
2. Hold the disk above the candle flame for some time. Observe and explain what happens.



Fig. 9.7: A rotating disk.

3. What makes the disk to rotate in such manner?
4. What else can be used to rotate the disk?
5. What are some of the uses of convection currents?

The disk starts to rotate. The rotation is due to the convection current set up. If a powerful electric bulb is available, you can make a rotating lamp shade.

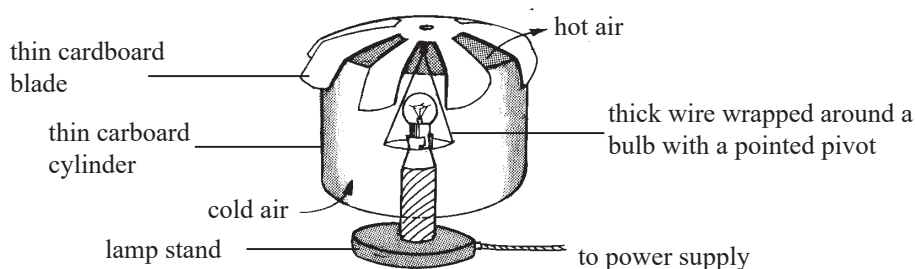

Fig. 9.8 : A rotating lamp shade

Convection currents possess energy. It is for this reason that steam is used to rotate the turbine in geothermal electric plants.

9.2.3 Heat transfer by radiation

9.2.3.1 The concept of radiation

If you stand in front of a fireplace, you feel your body becoming warm. Heat energy cannot reach you by conduction as air is a poor conductor of heat. How about convection? The hot air molecules in and around the fireplace can only rise and do not reach you by convection. How does the energy from the fireplace then reach you? Heat energy must be transferred by a different mode other than conduction and convection.

Activity 9.9

To demonstrate heat transfer by radiation

(Work in groups)

Materials:

- Thin tin lids painted black
- Wax
- Thumb tacks (match sticks)
- A bunsen burner

Part A

Steps

1. Take a thin tin lid painted black on one side. Stick a thumb tack with melted wax on the other side.
2. Keep the bunsen burner flame close to the painted side (Fig. 9.9). What happens? Explain.
3. Why do you think the thumb tack falls off after sometime. Explain?

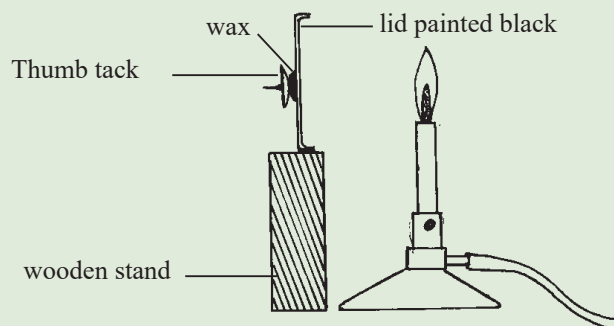

Fig. 9.9: Radiation

Part B

Steps

1. Take two thin tin lids, one with shiny inner side and the other with the inner side painted dull black.
2. Stick metal thumb tacks (or match sticks) on the outside of each lid using a little molten wax.
3. Keep a bunsen burner flame midway between the lids as shown in Fig. 9.10. Watch closely to and compare what happens to the two thumb tacks. Explain your observation.

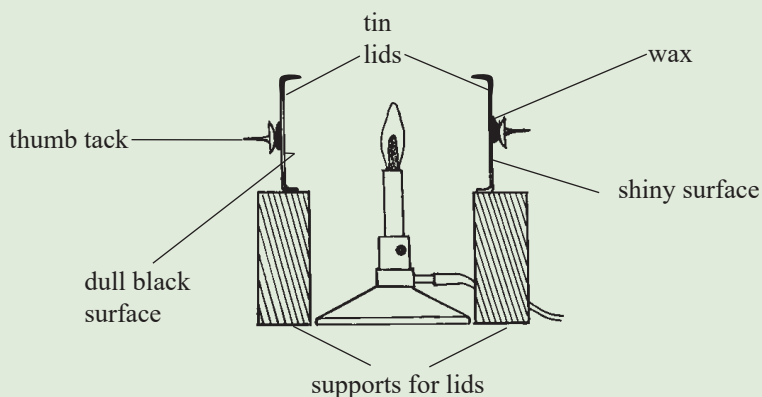

Fig. 9.10: Good and bad absorbers

As discussed in the case of the fireplace, the energy from the flame reaches the tin lid and the wax by a different mode other than conduction and convection. This third mode of heat transfer is called *radiation*. Radiation is the emission or transmission of energy in the form of a wave or particles through a material or space. Heat transfer from the sun travels through empty space (vacuum) and reaches the Earth. This energy is transferred by radiation. The surfaces of all luminous bodies emit radiation. A human face also emits some mild radiations. While conduction and convection need a medium to be present for them to take place, radiation can take place without a medium.

The amount of heat energy radiated depends upon the temperature of the body. In Activity 9.9, if the bunsen burner is replaced by a candle flame, it will take a longer time for the wax to melt. The temperature of the candle flame is lower than that of a bunsen burner.

Heat transfer can take place without contact or in a vacuum. This method of heat transfer is called *radiation*.

9.2.3.2 Good and bad absorbers of heat energy by radiation

If a black and shiny surface receive the same amount of heat energy by radiation, the black surface *absorbs* more heat than the shiny surface.

A dull black surface is a better *absorber* of heat radiation than a shiny surface.

Activity 9.10

To illustrate good and bad emitters of heat

(Work in groups)

Materials

- Three thermometers
- Three identical empty cans
- Three cardboards

Steps

1. Take three identical empty cans of the same volume with their tops removed. Apply clean and dry paints one white and the other black on two cans (both inside and out surfaces) and leave the third can shiny.
2. Prepare three suitable cardboard covers with holes at the centre. Fill the cans to the brim with hot water at 60°C .
3. Cover the cans with cardboards and place a thermometer in each can through the hole at the centre of the cardboard (Fig. 9.11).

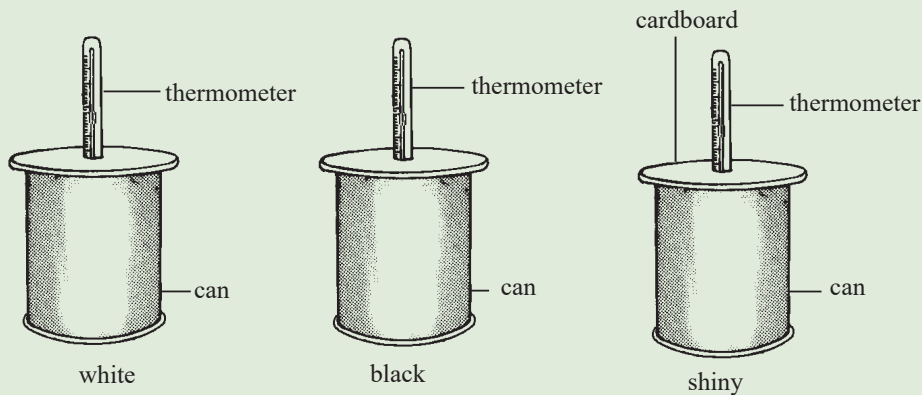

Fig. 9.11: Good and bad emitters

4. Record the temperature of water in the cans after a certain time interval.
5. Which can cools the water fastest?
6. Which can takes the longest time to cool the water? Explain the difference in the rate of temperature drop in the three cans.

A shiny surface is a good emitter than a dull black surface

9.2.4 Applications of heat transfer

Activity 9.11

To find out the applications of heat transfer

(Work in groups)

Materials

- Internet
- Reference books

Steps

1. You have learnt about heat transfer. Referring to this book or any other source, describe three ways in which heat transfer is important in our daily lives.
2. Do a research from the internet and reference books on the applications of heat transfer.
3. In your research, highlight clearly how the modes of heat transfer are applied in vacuum flasks, construction of ventilations, domestic hot water system and solar heating.
4. What other applications of heat transfer did you come across in your research?
5. Explain to your group members how natural phenomena like sea and land breeze take place.
6. Make a presentation on your findings to the whole class through your group secretary.

1. Vacuum flask

The vacuum flask popularly known as *thermos flask*, was originally designed by *Sir James Dewar*. It is designed such that heat transfer by conduction, convection and radiation between the contents of the flask and its surroundings is reduced to a minimum.

A vacuum flask, Fig. 9.12 is a double-walled glass container with a vacuum in the space between the walls. The vacuum minimises the transfer of heat by conduction and convection. The inside of the glass walls, is silvered so as to reduce heat losses by radiation. The felt pads on the sides and at the bottom support the vessel vertically. The cork lid is a poor conductor of heat.

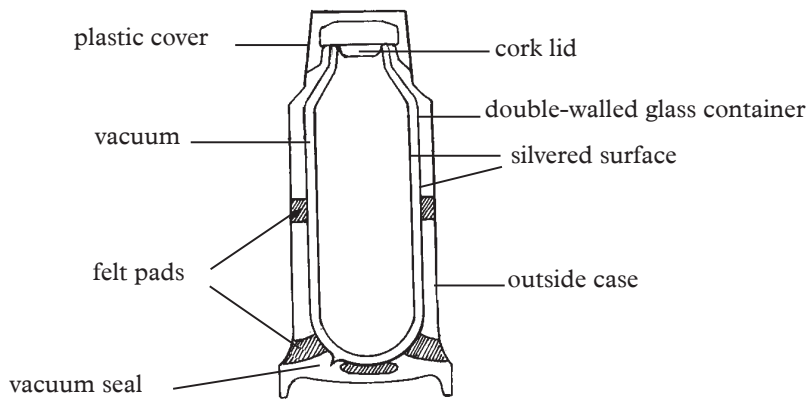

Fig. 9.12: Vacuum flask

When the hot liquid is stored, the inside shiny surface does not radiate much heat. The little that is radiated across the vacuum is reflected back again to the hot liquid, by the silvering on the outer surface. There is however some heat lost by conduction through the walls and the cork.

2. Windows and ventilators in buildings

As shown in Fig. 9.13, warm exhaled air of less density goes out through the ventilator and fresh air of high density enters through the windows at a lower level. This refreshes the air in a room.

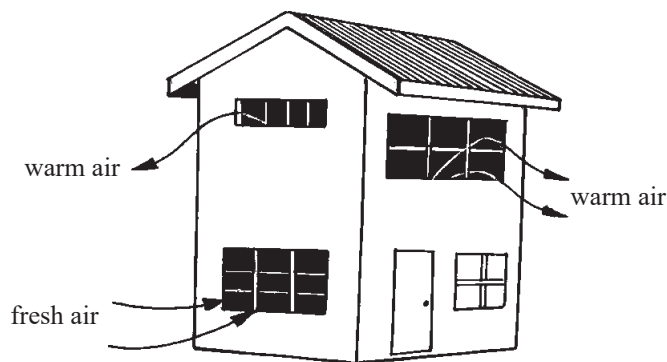

Fig. 9.13: Ventilation in building

3. Natural convection currents over the earth's surface

(a) Sea breeze

During the day, the temperature of the land rises faster than the temperature of sea water and the air over the land becomes warmer than the air over the sea water. The warm air of less density rises from the land allowing the cold dense air over the sea to blow to the land. This creates a sea breeze in the daytime (Fig. 9.14).

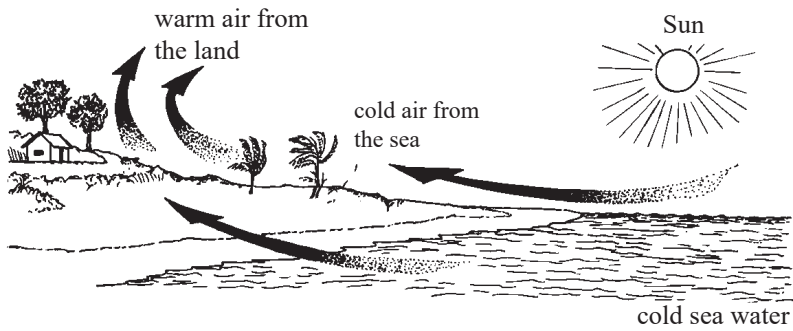

Fig. 9.14 Sea breeze

(b) Land breeze

During the night, the land cools faster than the sea water. Warm air from the sea rises and the dense air from the land moves to the sea. This sets up a land breeze in the sea (Fig. 9.15).

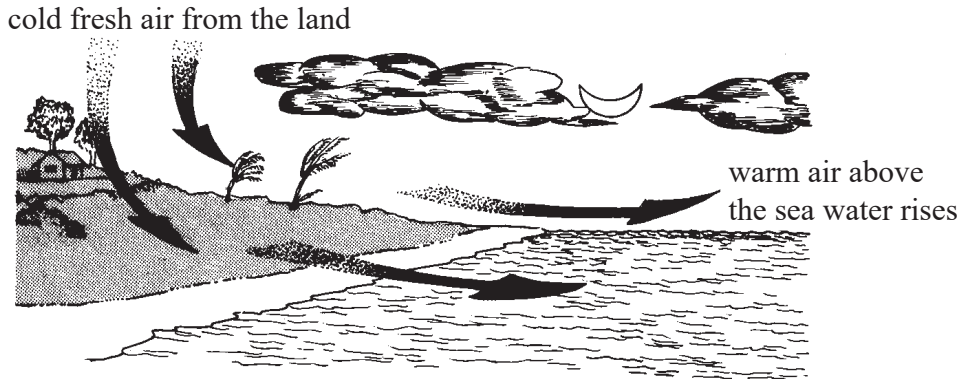

Fig. 9.15: Land breeze

4. Electrical devices

An electric kettle has its heating coil at the bottom. A refrigerator has the *freezing unit* at the top.

5. Domestic hot water system

A domestic hot water supply system works on the principle of convection current. A schematic diagram of a hot water supply is shown in Fig. 9.16.

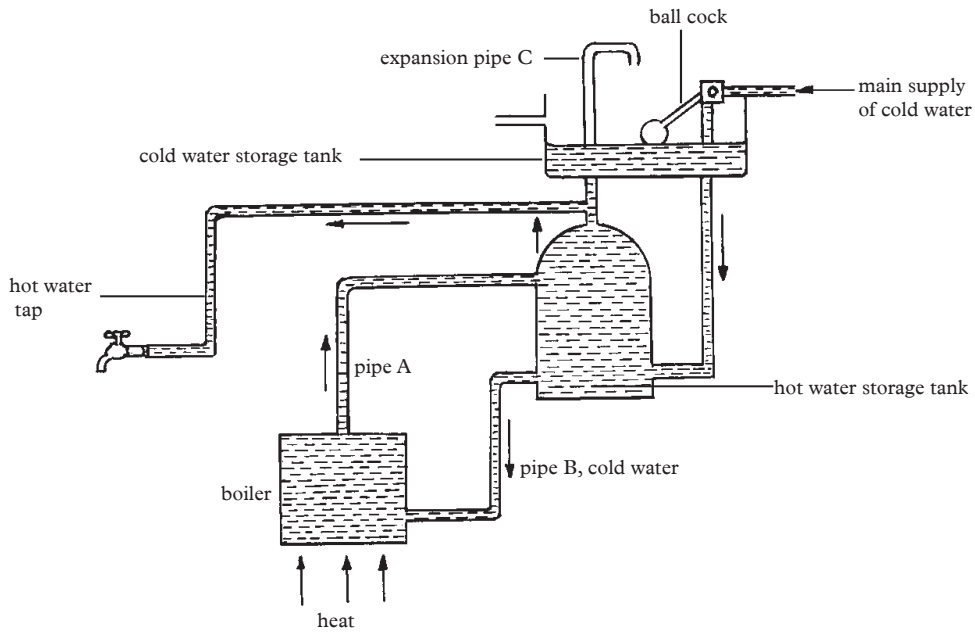

Fig. 9.16: Hot water system

Water is heated using fire wood, oil or electricity in the boiler. Hot water from the boiler goes up to the hot water storage tank through pipe A. Cold water flows down from the cold water storage tank into the boiler through pipe B (called return pipe).

When the hot water is being drawn from the top of the hot water storage tank, it is replaced by water from the main cold water tank built at the top of the house. The expansion pipe C allows steam and dissolved air to escape. This ensures that the tank does not explode due to the pressure created by the steam produced.

6. Solar heating

Flat plate collectors, called *solar panels*, are used to heat water. They can heat water up to 70°C . A solar panel consists of thin copper pipes, painted black, which carry the water to be heated. These tubes are fitted in a copper collector plate which in turn is fitted on to a good thermal insulator in a metal frame. A glass plate covers the panel (Fig. 9.17). These panels can be fitted on the roof of houses.

Heat radiation from the sun falls on the tubes and on the collector plate through the glass plate. The heat radiations trapped inside the panel by the glass plate heat the water. The hot water is then pumped to a heat exchange coil in a hot water tank which is connected to the domestic hot water system.

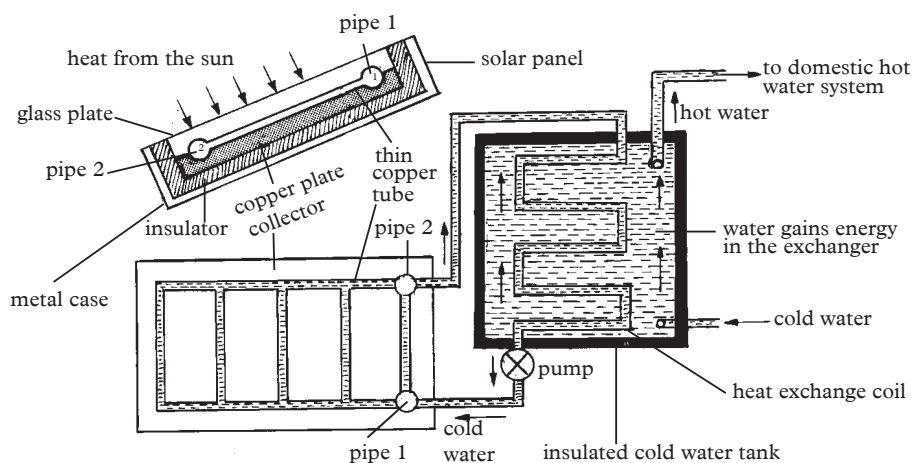

Fig. 9.17: Solar heating

7. Solar concentrations

In some heating devices, instead of a flat plate collector, curved mirrors (concave or parabolic) are used to concentrate the heat radiations from the sun to a small area at their focus. If the boiler is placed at the point of focus, very high temperatures can be reached.

Exercise 9.1

1. Distinguish between *heat* and *temperature*.
2. What are the different modes of heat transfer? Explain clearly their difference using suitable examples.
3. State three factors which affect heat transfer in metals. Explain how one of the factors you have chosen affects heat transfer.
4. Describe an experiment to show that water is a poor conductor of heat.
5. Use particle behaviour of matter to explain conduction.
6. Describe a simple experiment to demonstrate that the heat radiated from a hot body depends upon the temperature of the body.
7. With a suitable diagram, explain the working of a vacuum flask.

9.3 Thermal expansion

In general, nearly all substances increase in size when heated. The process in which heat energy is used to increase the size of matter is called *thermal expansion*. The increase in size on heating of a substance is called *expansion*. On cooling, substances decrease in size. The decrease in size on cooling of a substance is called *contraction*. Why is this so?

9.3.1 Thermal expansion and contraction in solids

When a solid (e.g. a metal) is subjected to heat, it:

- (a) Increases in length (Linear Expansion).
- (b) Increases in volume (Volume Expansion).
- (c) Increases in area (Surface Expansion).

9.3.1.1 Linear expansion

(a) Demonstrations of linear expansion

Activity 9.12

To demonstrate expansion and contraction using the bar and gauge apparatus

(Work in groups)

Materials

- A bar and gauge apparatus
- Bunsen burner

Steps

1. Move the metal bar in and out of the gauge at room temperature (Fig. 9.18). Observe what happens.

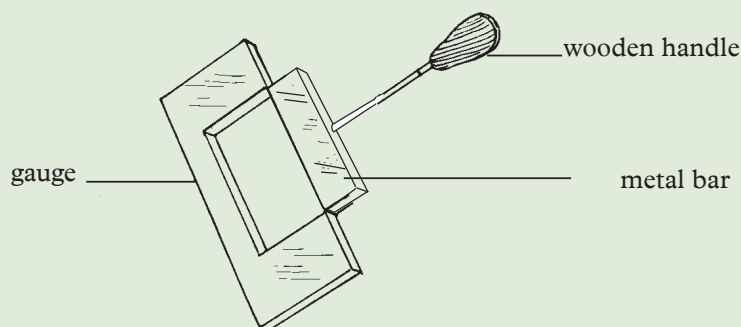

Fig. 9.18: Bar and gauge apparatus

2. Keep the metal bar away from the gauge and heat the bar for sometime.
3. Try to fit the bar into the gauge. Does it fit or not? Explain your observation.
4. Allow the bar to cool and try to fit it into the gauge. Does the bar now fit into the gauge? Explain.

A bar and gauge apparatus consists of a metal bar with a suitable wooden handle and a gauge. When both the metal bar and the gauge are at room temperature, the bar just fits into the gauge.

On heating, the metal bar expands. There is an increase in length. It hence expands linearly and therefore, the bar cannot fit into the gauge.

On cooling the bar easily fits into the gauge due to contraction.
Solids expand i.e increase in length on heating and contract i.e reduced in length on cooling.

Activity 9.13

To demonstrate the bending effect of expansion and contraction

(Work in groups)

Materials:

- A bimetallic strip
- Bunsen burner

Steps

1. Observe a bimetallic strip at a room temperature (Fig. 9.19).

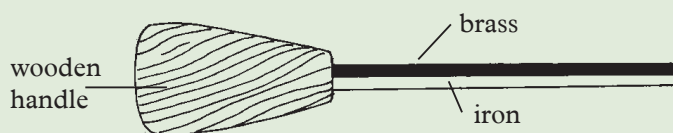
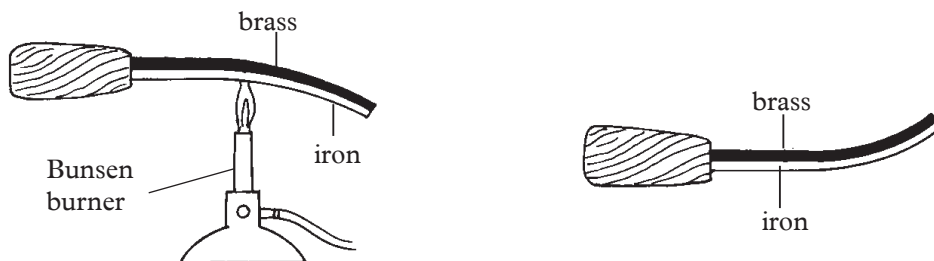

Fig. 9.19: A bimetallic strip

2. Take the bimetallic strip with the brass strip at the top and heat it with a bunsen burner flame for sometime. Observe what happens. Explain the observation. Sketch the shape of the bimetallic strip after heating.
3. Remove the flame and allow the bar to cool to a room temperature. What happens to the bimetallic strip? Sketch its shape after cooling.
4. Discuss with your friend what will happen if the bar is cooled below room temperature. Sketch the strip at that temperature.

When the bimetallic strip is heated, it bends downwards with the brass strip on the outer surface of the curvature, as shown in Figure 9.20(a). Why does this happen? When the flame is remove and the bar left to cool to room temperature, the bar returns back to its initial state (straight) as shown in Figure 9.19 above.

If the bar is cooled below room temperature, it bends upwards with the iron strip underneath as shown in Figure 9.20 (b). What has happened?



- (a) Heating the bimetallic strip (b) Cooling the bimetallic strip below room temperature

Fig. 9.20: Bending effect of expansion and contraction

As the bimetallic strip is heated, brass expands more than iron. The large force developed between the molecules of brass forces the iron strip to bend downwards. On cooling below a room temperature, the brass contracts more than iron and the iron strip is forced to bend upwards.

The force developed during expansion or contraction causes a *bending* of the metals.

(b) Comparison of rates of expansion of different solids

As we know from the kinetic theory of matter, the different states of matter expands when heated but at different rates.

The following activity shows that different solids have different rates of expansion.

Activity 9.14

To compare rates of expansion and contraction of different solids

(Work in groups)

Materials:

- Thin metal rods of different metals
- Source of heat
- Rollers connected to a pointer
- G - clamp

Steps

1. Clamp one end of a long thin metal rod tightly to a firm support, with the end of the rod resting on a roller fitted with a thin pointer (See Fig. 9.21).

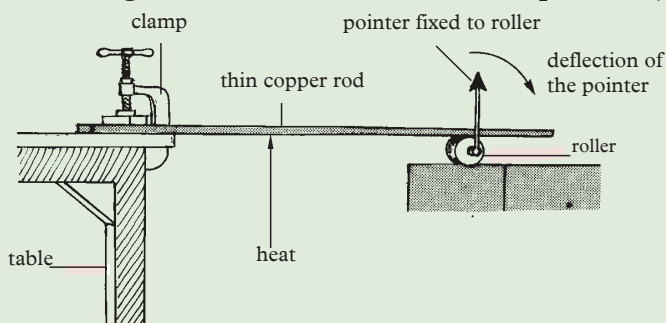

Fig. 9.21: Expansion and contraction of thin metal rods.

2. Heat the metal rod for sometime. Observe and explain what happens to the rod.
3. Remove the burner and allow the rod to cool. What happens to the rod again after cooling. Does it reduce in size? Explain why.
4. Repeat the activity with thin rods of different materials. Observe and explain what happens, accounting for any differences.

The pointer deflects in the clockwise direction on heating and in the anticlockwise direction on cooling.

The pointer deflects to different extents depending on the material.

On heating, there is an increase in length (linear expansion) of the rods. The expanding rod moves the roller to the right making the pointer attached to the roller to deflects in a clockwise direction. On cooling, the rod contracts and decreases in length. The contracting rod moves the roller to the left hence the pointer deflects in the opposite direction (anticlockwise direction).

When a different material e.g lead is used, the pointer deflects more to the right (clockwise). When cooled, the pointer deflects more to the left (anticlockwise).

Different solids (e.g metals) expand and contract to different extents when heated by the same quality of heat.

(c) Coefficient of linear expansion

Consider a thin metal of length l_0 in Fig. 9.22.

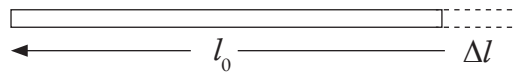

Fig. 9.22: A thin rod showing increase in length.

When the rod is heated, a temperature change of $\Delta\theta$ occurs and its length increases by Δl .

The ratio of increase or decrease in length to original length $\left(\frac{\Delta l}{l_0}\right)$ is directly proportional to the change in temperature $\Delta\theta$.

$$\frac{\Delta l}{l_0} \propto \Delta\theta \quad \Rightarrow \quad \frac{\Delta l}{l_0} = \alpha \Delta\theta \quad \text{and} \quad \alpha = \frac{\Delta l}{l_0 \Delta\theta}$$

where α is a constant called the **coefficient of linear expansion**. It is the value of the increase in length per unit rise in temperature for a given material. The SI units of α is K^{-1}

Suppose: The temperature change = $\Delta\theta$,

l_0 represents the original length of the rod

l represents the new length for a temperature rise of θ

Then, $\Delta l = l - l_0$

The above expression may be expressed in terms of l_0 , l , θ and α as follows.

$$\alpha = \frac{\Delta l}{l_0 \Delta\theta} = \frac{l - l_0}{l_0 \Delta\theta} \quad \text{Re-arranging} \quad l - l_0 = l_0 \alpha \Delta\theta$$

$$l = l_0 + l_0 \alpha \Delta\theta$$

$$l = l_0 (1 + \alpha \Delta\theta)$$

Example 9.1

A copper rod of length 2 m, has its temperature changed from 15 °C to 25 °C. Find the change in length given that its coefficient of linear expansion $\alpha = 1.7 \times 10^{-6} \text{ K}^{-1}$.

Solution

$$\Delta\theta = (25 - 15) \text{ }^\circ\text{C} = 10 \text{ }^\circ\text{C}$$

$$\Delta l = l_0 \alpha \Delta\theta = 2 \times 1.7 \times 10^{-6} \times 10$$

$$= 3.4 \times 10^{-5} \text{ m}$$

$$= 0.000034 \text{ mm}$$

9.3.1.2 Area and volume expansion

(a) Demonstrations of area and volume expansions

Activity 9.15

To demonstrate volume and surface expansion and contraction using the ball and ring apparatus

(Work in groups)

Materials:

- A ball and a ring
- Bunsen burner
- A bowl of cold water

Steps

1. Move the ball in and out of the metal ring at room temperature (see Fig. 9.23). What do you observe?
2. Keep the metal ball away from the ring and heat it for sometime.
3. Try to pass the ball through the ring. Does the ball pass through the ring this time? Why?
4. Cool the metal ball in a bowl of cold water and try to pass the ball through the ring again. Does it pass through the ring? Explain why.

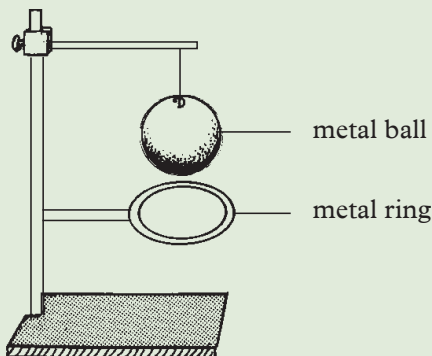

Fig. 9.23: Ball and ring apparatus

A *ball and ring* apparatus consists of a ball and ring both made of the same metal. At a room temperature, the ball and the metal ring have approximately the same diameter, thus the ball just passes through the ring. On heating, the metal ball expands. There is an increase in volume and surface area of the ball. As a result, the ball cannot pass through the ring. On cooling, contraction occurs and the original volume is regained. The ball can now pass through the ring again. This activity shows volume and surface area expansion and contraction in solids.

Most solids expand on heating and contract on cooling.

Why solids expand on heating?

In Secondary I, we learnt that molecules of a solid are closely packed and are continuously *vibrating* about their fixed positions. When a solid is heated, the molecules vibrate with larger amplitude about the fixed position. This makes them to *collide* with each other with larger forces which pushes them far apart. The distance between the molecules increases and so the solid expands. The reverse happens during cooling.

(b) Coefficients of area expansion of solids

Consider a solid whose surface area is A_0 .

When the surface of the solid is heated or cooled to a temperature change of $\Delta\theta$, its surface area increases or decreases by ΔA to a new value A .

Experiments have proved that the ratio of the change in surface area to original area i.e. $\frac{\Delta A}{A_0}$ is directly proportional to the change in temperature ($\Delta\theta$).

$$\frac{\Delta A}{A_0} \propto \Delta\theta \Rightarrow \frac{\Delta A}{A_0} = \beta \Delta\theta \quad (\beta \text{ is a constant called coefficient of area expansivity})$$

$$\text{Hence } \beta = \frac{\Delta A}{A_0 \Delta\theta} \quad \text{Or} \quad \beta = \frac{A - A_0}{A \Delta\theta} \quad (\text{since } \Delta A = A - A_0)$$

$$\Rightarrow A - A_0 = A_0 \beta \Delta\theta$$

$$A = A_0 + A_0 \beta \Delta\theta$$

$$\therefore A = A_0(1 + \beta \Delta\theta)$$

Note:

Coefficient of area expansivity = $2 \times$ coefficient of linear expansivity

$$\beta = 2\alpha$$

Example 9.2

A round hole of diameter 4.000 cm at 0°C is cut in a sheet of brass (coefficient of linear expansion is $19 \times 10^{-6}\text{k}^{-1}(\text{C}^\circ)^{-1}$). Find the new diameter of the hole at 40°C .

Solution

$$\Delta A = \beta A_0 (\theta_2 - \theta_1)$$

Given: $\alpha = 19 \times 10^{-6} \text{K}^{-1}$, $(\theta_2 - \theta_1) = 40^\circ\text{C}$, $D = 4.000 \text{ cm}$ so $r = 2.000 \text{ cm}$, $\beta = 2\alpha$
then

$$\begin{aligned} \text{Area } (A_0) &= \pi r^2 = \left(\frac{22}{7} \times 2.000 \times 2.000\right) \text{ cm}^2 \\ &= 12.971 \text{ cm}^2 \end{aligned}$$

$$\begin{aligned} \text{New area } A &= A_0 + \Delta A = (12.971 + 0.0197) \text{ cm}^2 \\ &= 12.991 \text{ cm}^2 \end{aligned}$$

$$\begin{aligned} \text{Since } A &= \pi r^2, \quad \text{the new radius } r = \sqrt{\frac{A}{\pi}} = \sqrt{\frac{12.987}{3.141}} \\ &= 2.033 \text{ cm} \end{aligned}$$

(c) Coefficients of volume expansion in solids

When a solid is heated or cooled to a temperature change of $\Delta\theta$, its volume increases or decreases by ΔV to a new value V .

The ratio of the change in volume to original volume i.e. $\frac{\Delta V}{V_0}$ is directly proportional to the change in temperature ($\Delta\theta$).

$$\frac{\Delta V}{V_0} \propto \Delta\theta \Rightarrow \frac{\Delta V}{V_0} = \gamma \Delta\theta \quad (\gamma \text{ is a constant called coefficient of volume expansivity})$$

$$\text{Hence } \gamma = \frac{\Delta V}{V_0 \Delta\theta} \quad \text{Or} \quad \gamma = \frac{V - V_0}{V_0 \Delta\theta} \quad (\text{since } \Delta V = V - V_0)$$

$$\Rightarrow V - V_0 = V_0 \gamma \Delta\theta$$

$$V = V_0 + V_0 \gamma \Delta\theta$$

$$\therefore V = V_0 (1 + \gamma \Delta\theta)$$

Note:

Coefficient of volume expansivity = 3 × coefficient of linear expansivity

$$\gamma = 3\alpha$$

Example 9.3

A metal vessel has a volume of 800.00 cm^3 at 0°C . If its coefficient of linear expansion is $0.000014/\text{K}$, what is its volume at 60°C ?

Solution

Given: $V_0 = 800.00 \text{ cm}^3$, $(\theta_2 - \theta_1) = 60^\circ\text{C}$ and $\alpha = 0.000014/\text{K} = 0.000014/^\circ\text{C}$

$$\begin{aligned}\text{Change in volume, } (\Delta V) &= 3 \alpha V_0 \Delta \theta \\ &= 3(0.000014/^{\circ}\text{C}) \times 800.00 \text{ cm}^3 \times 60^{\circ}\text{C} \\ &= 2.016 \text{ cm}^3\end{aligned}$$

$$\begin{aligned}\text{New volume (at } 60^{\circ}\text{C)} &= V_0 + \Delta V \\ &= (800.00 + 2.016) \text{ cm}^3 \\ &= 802.016 \text{ cm}^3\end{aligned}$$

Exercise 9.2

1. What do you understand by the phrase '*coefficient of linear expansion*'?
2. A vertical steel antenna tower is 400 m high. Calculate the change in height of the tower hence its new height that takes place when the temperature changes from -19°C on winter day to 39°C on a summer day.
(Take $\alpha = 0.00000649/\text{K}$)
3. A 8 m long rod is heated to 90°C . If the rod expands to 10 m after some time, calculate its coefficient of linear expansion given that the room temperature is 32°C .
4. A rectangular solid of Brass has a coefficient of volume expansion of $96 \times 10^{-6}/^{\circ}\text{C}$. The dimensions of the rectangle are 9 cm \times 6 cm \times 8 cm at 10°C . What is the change in volume and the new volume if the temperature increases to 90°C ?
5. A solid plate of lead of linear expansion $29 \times 10^{-6}/^{\circ}\text{C}$ is 8 cm \times 12 cm at 19°C . What is the change in area and the new area of the lead if the temperature increases to 99°C ?

9.3.2 Thermal expansion and contraction in liquids

Like solids, liquids expand on heating i.e volume increases and contract i.e Volume reduces on cooling. But liquids expand more than solids since they have relatively weak intermolecular forces. Activity 9.17 will help us to understand expansion and contraction in liquids.

Activity 9.16

To demonstrate expansion and contraction in liquids

(Work in pairs or in groups)

Materials:

- A glass flask
- Coloured water
- Tripod stand
- A rubber stopper
- Bunsen burner
- Wire gauze
- Long glass tubing

Steps

1. Fill a glass flask with coloured water.
2. Fit the flask with a rubber stopper carrying a long narrow glass tubing.
3. Note the initial level of water in the glass tube before heating (Fig. 9.24).

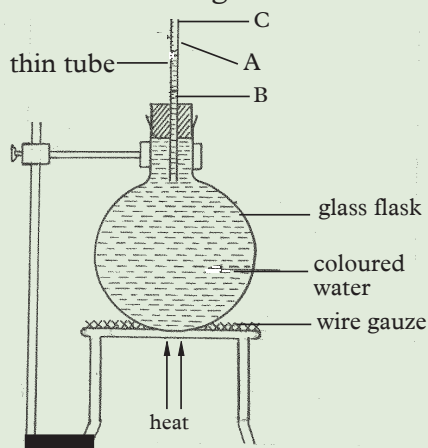

Fig. 9.24: Expansion of liquid

4. Heat the water in the flask. What happens to the level of water at A immediately the heating starts and after a few minutes? Explain your observation.

In a similar activity, it was observed that at first the level of the coloured water in the tube drops to level B and then rises to level C.

On heating, the glass flask is heated first and expands i.e its volume increases. The level of water immediately drops from A to B. On continuous heating, water starts to expand hence water level rises up the tube from B to C.

If the setup is allowed to cool below room temperature, the water level drops to a point lower than A and B.

This shows that liquids expand on heating and contract on cooling.

Why liquids expand on heating?

Molecules are loosely packed in liquids. The force of attraction between the molecules is weaker than in solids. The molecules move freely in the liquid. On

heating, the speed of the molecules increases. The collisions between the molecules increases the distance between them causing the liquid to expand.

9.3.3 Thermal expansion and contraction in gases

Just like solids and liquids, gases expand on heating and contract on cooling. Gases expand more than liquids and solid because their molecules move furthest on heating. The following activity will help us to study expansion and contraction in gases.

Activity 9.17

To demonstrate expansion of gases

(Work in pairs or in groups)

Materials:

- A thin glass flask
- A rubber stopper
- A long narrow glass tube

Steps

1. Take a thin glass flask with an open top.
2. Close the flask with a rubber stopper carrying a long narrow glass tube.
3. Invert the flask so that the glass tube dips into water in a container. What do you observe? (Fig. 9.25).

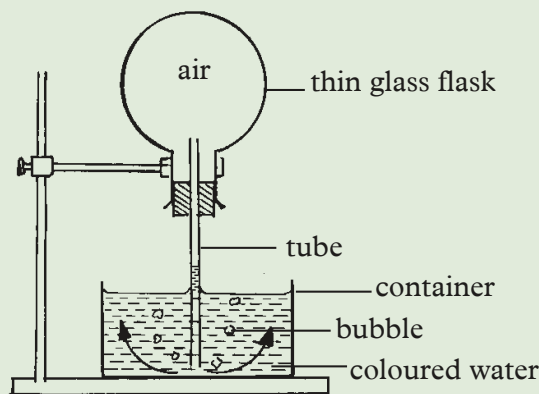

Fig. 9.25: Expansion of air

4. Place your hands over the flask to warm it for sometime. What happens in water. Explain your observation.
5. Remove your hands from the flask and wait for some time. What happens to the level of water in the tube of the flask. Explain your observation.

When the flask is warmed by the warmth of the hands, the level of water in the tube drops and some bubbles are formed due to air escaping from the flask through the tube.

On removing the hands from the flask, water level rises up the glass tube again due to contraction of air i.e volume of air reduces on cooling. This shows that gases expand on heating and contract on cooling..

The volume of air increases in the flask due to expansion.

Why a gas expands on heating?

The force of attraction between the molecules of a gas is very small (almost negligible) and the distance between the molecules is large compared to solids and liquids. The molecules move freely in all directions. When a gas is warmed, the molecules gain more energy and move far apart hence volume increases.

Different gases expand by the same amount when heated equally.

Gases contract on cooling and expand on heating.

9.3.4 Applications of thermal expansion and contraction

Activity 9.18

To find out the applications of expansion and contraction

(Work in pairs or in groups)

Materials

- Internet enabled devices (lab computers or tablets)
- Reference books

Steps

1. You have now learnt about expansion and contraction. Suggest any three applications of expansion and contraction in our daily lives.
2. Carry out a research from the internet on the applications of expansion and contraction.
3. Report your findings to the whole class.

Thermal expansion and contraction, on one hand is a nuisance and on the other hand is quite useful. The following are some of the applications of thermal expansion and contraction.

1. Electric thermostats

A *thermostat* is a device made from a bimetallic strip that is used to maintain a steady temperature in electrical appliances such as electric iron boxes, refrigerators, electric geysers, incubators, fire alarms and the automatic flashing unit for indicator lamps of motor cars. Fig. 9.26 show two such devices.

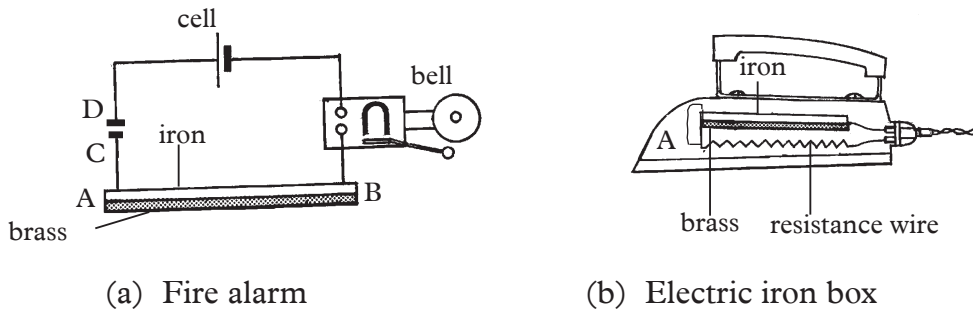

Fig. 9.26: Electric appliances with thermostat

The bimetallic, as discussed earlier, bends on expansion and relaxes on cooling, connecting and disconnecting the circuit to regulate temperature.

Be responsible and take care!

Conserve energy by switching off the socket after using electrical appliances. Be careful when using electrical devices to avoid electric shocks.

2. Ordinary and pyrex glasses

You may have observed that when boiling water is poured into a thick-walled glass tumbler it may break suddenly. This is because the inside of glass gets heated and expands even before the outside layer becomes warm. This causes an unequal expansion between the inside and the outside surfaces. The force produced by the expanding molecules on the inside produces a large strain in the glass and the tumbler breaks. This is the reason why pyrex glass tumblers are recommended for use while taking hot liquids.

3. Rivets

In industries, steel plates are joined together by means of *rivets*. Hot rivets are placed in the rivet holes and the ends hammered flat. On cooling the force of contraction pulls the plates firmly together (Fig. 9.27).

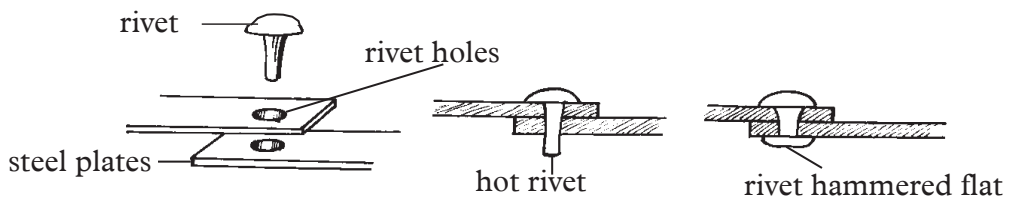

Fig. 9.27: Rivets

4. Expansion of joint loops

Metal pipes carrying steam and hot water are fitted with *expansion joint* or loops. These allow the pipes to expand or contract easily when steam or hot water passes through them or when the pipes cool down. The shape of the loop changes slightly allowing necessary movement of the pipes to take place (Fig. 9.28).

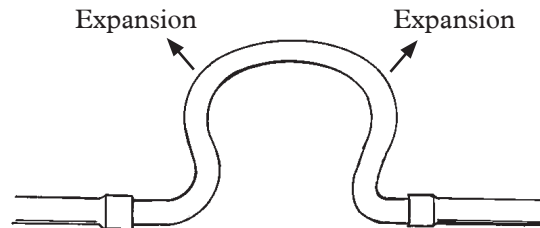

Fig. 9.28: Expansion joint

5. Loosely fitted electric cables

Telephone and electricity cables are loosely fitted between the poles to allow room for contraction in cold weather and expansion in hot weather.

6. Use of alloys

The *measuring tape* used by surveyors for measuring land is made of an alloy of iron and nickel called *invar*. Invar has a very small change in length when temperature changes.

7. Gaps in railway tracks

Gaps are left between the rails when the railway tracks are laid. The rails are joined together by *fish-plates* bolted to the rails. The oval shaped bolt holes allow the expansion and contraction of the rails when the temperature changes (Fig. 9.29).

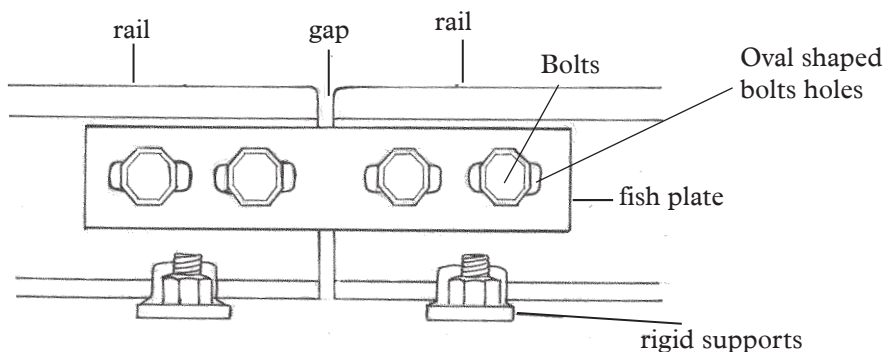

Fig. 9.29: Gaps left between rails

In very hot weather, the gaps may not be enough if the expansion is large. The rails may *buckle* out. Modern methods use long welded lines rigidly fixed to the beds of the track so that the rails cannot expand. Expansion for the rails is provided by overlapping the plane ends (Fig. 9.30).



Fig. 9.30: Overlapping joints

8. Rollers on bridges

The ends of steel and concrete bridges are supported on rollers. During hot or cold weather, the change in length may take place freely without damaging the structure (See Fig. 9.31).

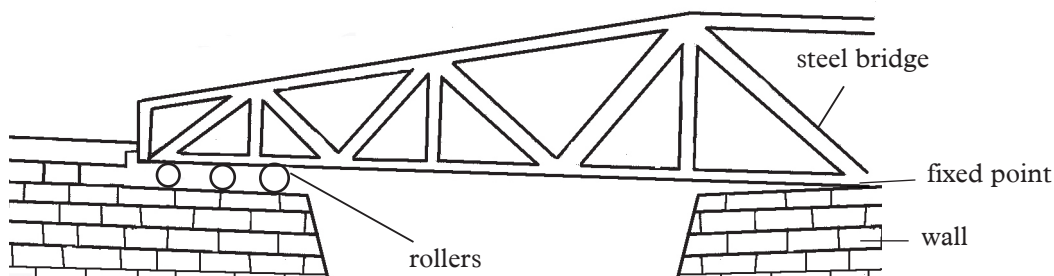

Fig. 9.31: Steel and concrete bridges are supported on rollers

9. Breakages

Activity 9.19

To demonstrate causes of expansion and contraction

(Work in pairs)

Materials:

- A beaker
- An immersion heater
- A thermometer
- Water
- A measuring cylinder
- Stop watch

Steps

1. Take 200 g of water in a beaker and note its initial temperature θ_1 .
2. Heat the water with an immersion heater for 10 minutes (Fig. 9.32 (a)). Note the final temperature θ_2 and calculate the change in temperature, $\Delta\theta = \theta_2 - \theta_1$.
3. Repeat (2) above by taking 400 g of water in the same beaker and same initial temperature θ_1 (Fig. 9.32 (b)). Note the time taken to produce the same change in temperature as before. Is it more or less?
4. Compare the time taken to produce the same change in temperature in 200g and 400g of water. What is your conclusion?

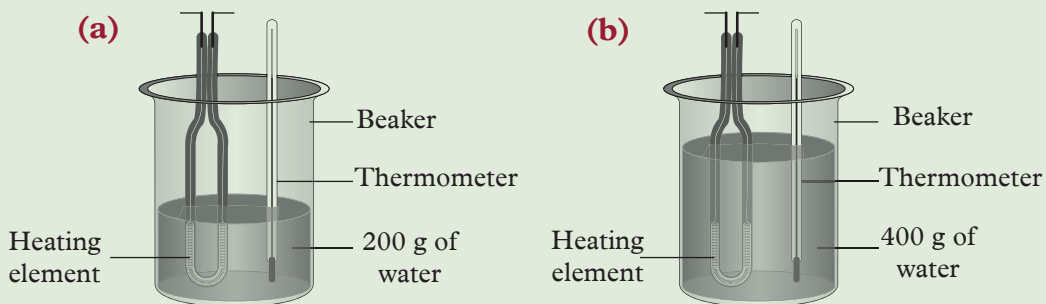

Fig. 9.32: Relationship between heat energy and mass of the substance

Sudden expansion and contraction can lead to breakages of things like glasses and egg shells. This behaviour is mitigated against in the manufacture of glass items such as the drinking glass. They are made of thin walls to allow even expansion and contraction thus minimising chances of breakage.

Exercise 9.3

1. Use particles model to explain thermal expansion of solids.
2. Explain why:
 - (a) Steel bridges are usually supported by rollers on one loose side.
 - (b) Metal pipes carrying steam and hot water are fitted with loops.
3. Describe how shrink fitting is done.
4. State two applications of contraction of solids.
5. Name three physical properties that change when heating a solid.

Topic summary

- **Heat** is a form of energy which is transferred from a region of higher temperature to a region of lower temperature.
- The SI unit of heat energy is **Joule (J)**.
- Two substances of equal masses can be at the same temperature but contain different amounts of heat energy and vice-versa.
- Heat energy can be transferred by three different modes: **conduction, convection** or **radiation**.
- Solids are heated by conduction and fluids by convection. Radiation can take place through vacuum.
- We get heat energy from the sun by radiation.

Topic Test 9

For questions 1 – 9, select the correct answer from the choices given.

1. Radiation in a thermos flask is minimized by
 - A. Cork
 - B. Vacuum
 - C. Felt pad
 - D. Silvered glass water
2. A dull black surface is a good
 - (i) Absorber of heat energy
 - (ii) Emitter of heat energy
 - (iii) Reflector of heat energy
 - A. (i) only
 - B. (i) and (ii) only
 - C. (ii) and (iii) only
 - D. (i), (ii) and (iii)
3. Radiation is the transfer of heat _____
 - A. in a liquid which involves the movement of the molecules.
 - B. from one place to another by means of electromagnetic waves.
 - C. through a material medium without the bulk movement of the medium.
 - D. through a fluid which involves the bulk movement of the fluid itself.
4. The mode of transfer of heat between the boiler and the storage tank of a hot water supply system is
 - A. radiation
 - B. conduction
 - C. convection
 - D. evaporation

Topics in the unit

Topic 10: Magnetism

Learning outcomes**Knowledge and Understanding** >>> ●

- Understand the theory of magnetism and explain the properties of magnets.

Skills >>> ●

- Design investigations to determine the polarities of magnets, methods of magnetization and demagnetization, and how to distinguish between magnets and non-magnets.
- Carry out accurate observation.
- Recording results accurately in appropriate way.
- Analysis of results in groups.
- Explain analysis and consider applications.

Attitudes >>> ●

- Appreciate the properties of magnets in construction of simple compass.

Key inquiry questions >>> ●

- Why a compass needle does always points to the north?
- Why that some magnets are classified as strong?
- Why that a point is identified as neutral in magnetic field lines?
- Why would you shield a small compass needle from earth's magnetic field?
- Why do we use soft iron keeper?

Unit Outline >>>

- Definition of a magnet
- Magnetic and non-magnetic materials
- The poles of bar magnet
- Test for magnetism
- Types of magnets

Introduction

The people of Magnesia in Asia Minor observed that certain kinds of naturally occurring iron ores possessed an iron-attracting property. The ore was discovered near the city of Magnesia and hence it was named as **Magnetite**. Huge lumps of magnetite were often called lodestone meaning “leading” stone or natural magnet. Chemically lodestone consists of iron oxide.

Dr. William Gilbert (1540-1603) did a lot of work with the natural magnets. He published a book called *De magnete* in 1600 in which he gave an account of his research into the magnets and their properties. In one of his work he concluded that the earth was itself magnetic and that is why compasses point to the north of the earth.

10.1 Definition of a magnet**Activity 10.1****To identify magnets**

(Work in groups)

Materials: Cooking stick, steel nail, a bar magnet, a spanner, a cork

Steps

1. Identify a magnet from the materials provided (see Fig. 10.1). Suggest a reason why you think the material you have identified is a magnet.



(a)



(b)



(c)

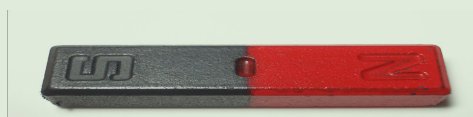

(d)



(e)

Fig. 10.1: Magnetic and non-magnetic materials

2. Discuss in your group what a magnet is.

From Activity 10.1, you observed that Fig. 10.1 (d) is a magnet. A magnet is a *piece of metal with either natural or induced properties of attracting another metal objects e.g. steel*. The common type of a magnet used in school laboratory is a bar magnet (Fig. 10.1 (d)). We shall learn about types of magnets later.

10.2 Magnetic and non-magnetic materials

Materials may be classified according to their magnetic properties. There are those that are attracted by magnets and others that are not.

Identifying magnetic and non-magnetic substances

Activity 10.2

To identify magnetic and non-magnetic substances

(Work in groups)

Materials: Iron and steel nails, bar magnet, copper metal, cobalt, wood, zinc, glass rods

Steps

1. Place some iron nails on the table. Bring a bar magnet close to the iron nails and observe what happens. Explain your observations.
2. Repeat the activity with other material such as copper, cobalt, steel, sulphur, brass, wood, cork, nickel, plastic, pens, wax, zinc, glass rods, carbon, aluminium, paper, chalk etc.
3. Record your observations in tabular form as shown in Table 10.1.

Table 10.1: Magnetic and non-magnetic materials

Substances attracted by a bar magnet	Substances not attracted by a bar magnet
1.	1.
2.	2.
3.	3.
4.	4.

4. Discuss your observations in step 3 in your group and suggest the name given to substances that are attracted by a magnet and those that are not.

The results from Table 10.1 shows that some materials are attracted by the bar magnet while others are not.

The materials which are attracted by a magnet are called *magnetic materials* while those which are not attracted are called *non-magnetic materials*. The magnetic materials that are strongly attracted by a magnet are called *ferromagnetic materials*. These include *nickel, iron, cobalt* and *steel*.

Materials that are not attracted by a magnet are called non-magnetic materials. Examples of *non-magnetic materials* include *copper, brass, aluminium, wood, cork, plastic* etc.

When metals are mixed together, they form *alloys*. Some *alloys* are ferromagnetic materials. An example is Al-ni-co which composed of aluminium (Al), nickel (Ni) and cobalt (Co) hence the name *Al-ni-co*. Another example of alloys which are those composed of nickel, iron, copper, chromium or titanium; they are also ferromagnetic.

10.3 Properties of magnets

(a) Polarity property of magnets

Activity 10.3

To identify the poles of a magnet

(Work in groups)

Materials: A bar magnet, iron filings in a container, a paper

Steps

1. Lay a bar magnet on a bench and cover it with a piece of paper.
2. Sprinkle the iron filings over the paper. What happens to the iron filings? Explain your observations.
3. Which parts have attracted more iron filings?
4. Suggest the name given to the ends of a magnet.

From Activity 10.3, you must have noted that the iron filings were attracted by a bar magnet. Most iron filings remained clustered around the ends of the magnet as shown in Fig. 10.2.

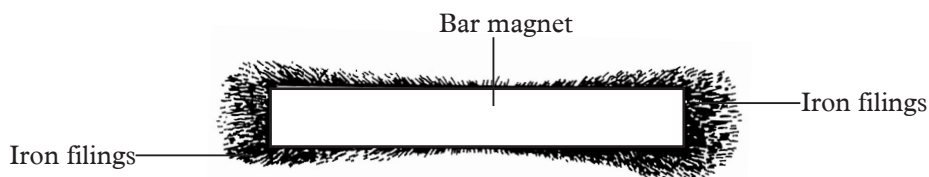

Fig. 10.2: Distribution of iron filings around a bar magnet.

The ends of a magnet where the attraction is strongest are known as the *magnetic poles*. Magnetic poles are the places in a magnet where the total attractive force seems to be concentrated. A straight line drawn passing through these ends is called the *magnetic axis* of the magnet (see Fig. 10.3).

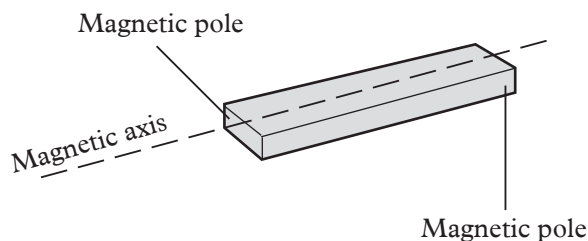

Fig. 10.3: Magnetic poles and magnetic axis of a bar magnet.

A bar magnet has the strongest attraction at the poles.

(b) Directional property of a magnet

Activity 10.4

To observe the directional property of a magnet

(Work in groups)

Materials: A bar magnet, 1 metre long thread

Steps

1. Suspend a bar magnet freely at its centre by a length of a cotton thread from a support (Fig. 10.4 (a)). Make sure there are no steel or iron objects near the magnet.

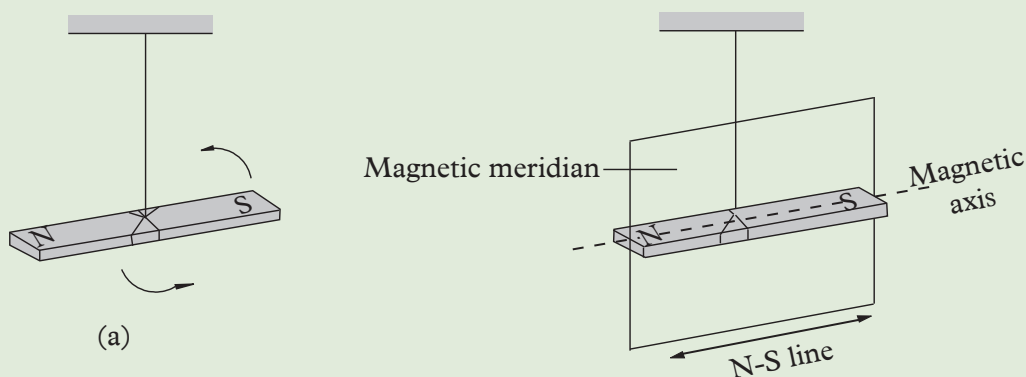

Fig. 10.4: A freely suspended magnet

2. Displace the magnet slightly so that it swings in a horizontal plane.
3. Note the direction in which the magnet finally comes to rest. Suggest a reason why it rests in that direction.
4. Repeat the activity at different places and note the resting direction of the magnet. What do you observe about the resting direction of the magnet? Explain the direction of the magnet when it rests.

In Activity 10.4, you observed that the bar magnet swings to and fro and finally rests in a north-south (N-S) direction of the earth.

The magnet comes to rest with its axis in a vertical plane called the *magnetic meridian* (Fig. 10.4 (b)) i.e. a bar magnet rests in a north-south direction.

The pole that points towards the north pole of the earth is called the *north seeking pole* or simply the *north pole* (N). The other pole is called the *south seeking pole* or *south pole* (S).

Identifying the poles of a magnet by colour

Activity 10.5

To identify the poles of a magnet by colour

(Work in groups)

Materials: A bar magnet, 1 metre long thread

Instructions

1. In this activity you will conduct an investigation to identify the poles of a magnet.
2. Write a brief procedure of the investigation. Execute the procedure and conduct the investigation. After the activity answer the following questions.
3. Compare the direction shown by the compass and that of the suspended bar magnet.
4. Note the pole of the suspended bar magnet that is pointing in the same direction as north pole or south pole of the magnetic compass. Deduce the poles of the magnet.
5. Write a report on poles of magnets and present it in a class discussion.

From Activity 10.5, you noted that the pole that points in the direction of the north of the compass is the north pole and the other pole is the south pole.

In order to easily identify the poles of a magnet, the ends are usually painted in different colours. For example, the *N-pole* is painted *red* while the *S-pole* is painted *blue* or *white* Fig 10.5 (a). In other cases the whole bar is painted blue with a red dot or spot on one end to identify the north pole. (See Fig. 10.5 (b)).

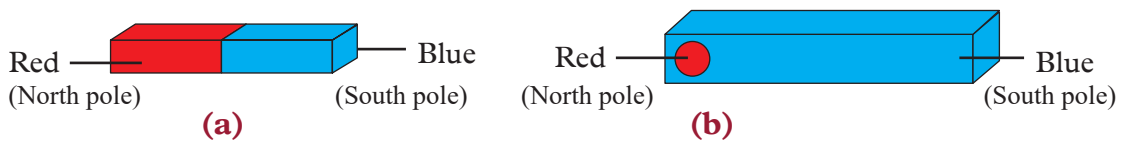

Fig. 10.5: Colours used to identify poles of a bar magnet

Hey!!



Do you know that the red colour in our national flag symbolises the blood that was shed for the independence of our country. Let us always live happily with one another and keep peace in our beautiful country.

10.4 Test for magnetism

Basic law of magnetism

Activity 10.6

To establish the basic law of magnetism

(Work in groups)

Materials: Two bar magnets, cotton thread.

Steps

1. Suspend a bar magnet using a light cotton thread with its north and south pole clearly marked.
2. Bring a S-pole of a second bar magnet slowly towards the S-pole of the suspended magnet (Fig. 10.6(a)). What happens to the magnets.
3. Repeat the activity using the S-pole of the suspended magnet and the N-pole of the second magnet (Fig. 10.6 (b)). What happened to the magnets?

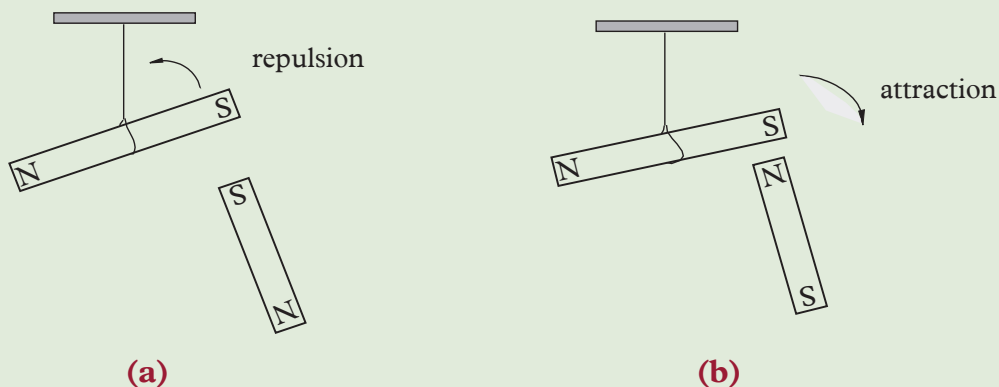

Fig. 10.6: Action of magnets on each other.

4. Repeat using the other poles and record your observation in a tabular form as shown in table 10.2.

Poles of suspended magnet	Pole of second magnet	Observation
South	South	_____
South	North	_____
North	South	_____
North	North	_____

Table 10.2: Test for magnetism

5. Why does some poles attract whereas others repel each other?

From Activity 10.6, you must have discovered that a north pole attracts a south pole, a north pole repels a north pole and a south pole repels a south pole.

Therefore, *unlike poles attract each other while like poles repel each other*. This is called the *basic law of magnetism*.

In the previous class, we learnt about charges. Like charges repel whereas unlike charges attract. The same concept is applied in the basic law of magnetism. Like poles repel whereas unlike poles attract.

Testing the polarity of magnets using the basic law of magnetism

Activity 10.7

To test for polarity of magnets using the basic law of magnetism

(Work in groups)

Materials: A nail, two bar magnets, a cotton thread

Steps

1. Freely suspend a bar magnet as shown in Fig. 10.7.
2. Bring one pole of the magnet close to a nail placed on a table. What happens to the nail?

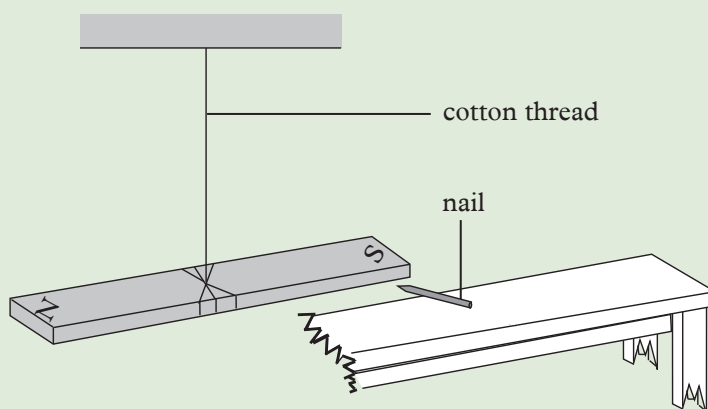

Fig. 10.7: Testing the polarity of a magnet.

3. Repeat with the other pole close to the nail and record your observations.
4. Repeat steps 2 and 3 using a second bar magnet instead of the nail. What do you observe? Discuss your observations.

From Activity 10.7, you must have observed the following:

1. There is attraction when the south or north pole of the suspended magnet is brought near the nail.
2. When the second bar magnet is used, there is attraction with one pole and repulsion with the other pole.

Therefore, there is always attraction between a magnet and a magnetic material and also between the unlike poles of magnets. But there is repulsion only between two like poles of magnets.

Repulsion is therefore, **the only sure way of testing for polarity** of a magnet.

10.5 Types of magnets

Activity 10.8

To magnetise a piece of iron nail

(Work in groups)

Materials: A piece of soft iron nail (about 3 inches), about 1 m of thin coated copper wire, a fresh size D dry cell, iron filings, cello tape.

Steps

1. Leave about 15 cm of wire loose at one end and wrap part of the remaining section of the wire around the nail.
2. Cut the wire (if needed) but ensure that there is at least 15 cm of wire loose on the other end too.
3. Remove about 2 cm of the plastic coating from each end of the wire. Attach one end of the wire to terminal of the dry cell, and the other end of the wire to the other terminal of the battery using a cello tape (Fig 10.8). Be careful though, the wire might get very hot!

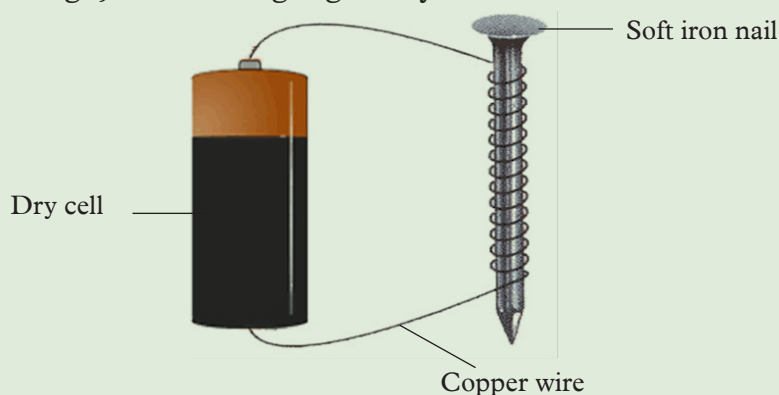

Fig. 10.8: Magnetising a piece of iron nail

4. Bring one end of the nail near the iron filings. What do you observe? Explain.
5. Disconnect one end of the wire from the dry cell. What happens to the iron filings? Explain.
6. Repeat the activity by replacing soft iron nail with a steel nail and increase current by adding more new dry cells to the circuit. What do you observe? Explain your observations to other members in your group.

From Activity 10.8, you must have noted that the soft iron nail attracts the iron filings only when the circuit is complete i.e., when electric current is flowing through the wire. This shows that the iron nail becomes a magnet. This kind of a magnet which is made by passing current through a coil is called an *electromagnet*.

When the circuit is disconnected, no current will flow in the wire, hence the iron nail does not attract the iron filings. The electromagnet is a **temporary magnet**.

When the steel nail was used instead of iron nail and current was increased, the iron filings did not fall off after being attracted and the circuit disconnected. Hence, the steel nail becomes a **permanent magnet**.

Therefore, there are two basic types of magnets; permanent and temporary magnets.

(a) Permanent magnets

In Activity 10.8, you should have observed that the steel nail retained its magnetism for a longer time. **Permanent magnets** are those magnets that retain magnetic properties for a long time. They are made from hard magnetic materials e.g steel. An example of naturally occurring permanent magnet is lodestone, which is composed of a mineral called magnetite.

Other permanent magnets are made from mixing magnetic materials (such a mixture is known as an *alloy*). Examples of alloys commonly used to make permanent magnets are *Al-ni-cos* i.e iron alloys containing aluminium, nickel, and cobalt. Steel which is mixture of carbon and iron and materials containing rare-earth elements like samarium, neodymium or ferrites (an oxide of iron).

Permanent magnets can be made into any shape to fit the usage. They can be made into round bars, rectangles, horse-shoes, donuts, rings, disks and other custom shapes. Fig 10.9 shows some permanent magnets named according to their shapes.

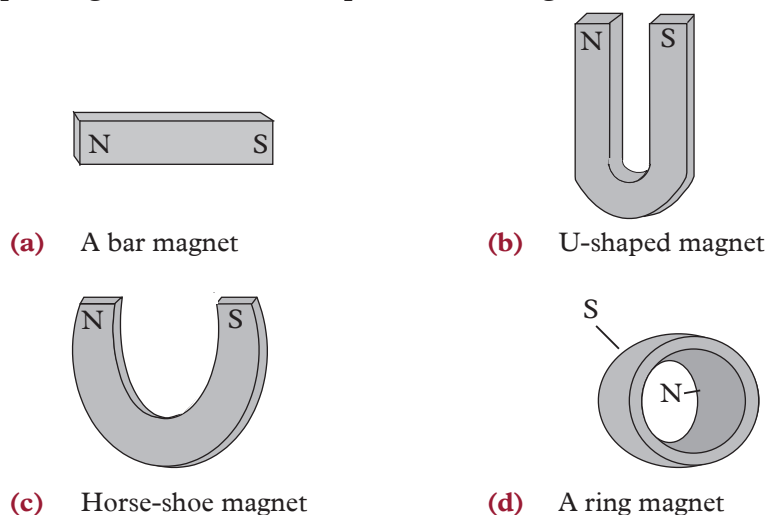

Fig. 10.9: Shapes of permanent magnets.

Fig 10.10 shows a *ceramic* or *magnadur* magnet. The poles of ceramic magnet are at its *faces* (Fig. 10.10). These types of magnets are stronger than other magnets

of comparable size. They are greyish/black in colour. Magnadur magnets consist of basically iron oxide and barium oxide.

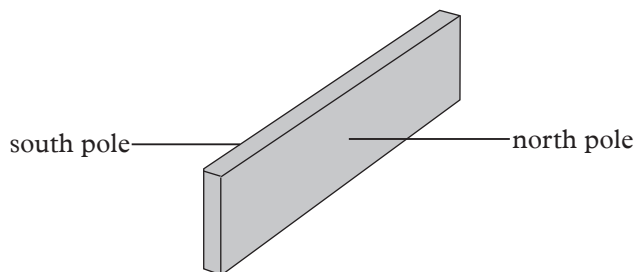

Fig. 10.10: Ceramic magnet (magnadur).

Uses of permanent magnets

Permanent magnets are used to lift heavy loads in industries. They handle loads with extreme easiness in the minimum area. This makes them efficient because they always operate from the top without compressing or deforming the load.

Note:



Note: A permanent magnet system for lifting loads is safe since it is not affected by any electrical power failure. Therefore, no battery or generator backup system is required.

Other uses of permanent magnets include:

1. Removing of iron pieces from the eyes of patients in hospitals.
2. Setting of six's maximum and minimum thermometer in weather stations.
3. To show the direction as in compass needles for navigation.
4. Magnetic tapes use permanent magnets in audio and video recorders.
5. They are used in Jewellery e.g earring, bracelets, necklaces to assist them clapsed (closed).

(b) Temporary magnets

From Activity 10.8, you should have established that temporary magnets are those magnets which act as magnets only when there is a *flow of electric current* or a *presence of a permanent magnet*. They loose magnetism when the permanent magnet is removed or electric current is cut off. Some may retain weak magnetic properties. They are made using *soft magnetic materials* like soft iron, iron-silicon alloys and iron-nickel alloys. An example of temporary magnet is an *electromagnet*.

A simple electromagnet is made by winding a wire carrying current round a soft magnetic material and then connecting the wire in a simple circuit.

Uses of temporary magnets

1. Electromagnets are used in motors, loud speakers, telephone, earphones and among other devices.
2. To separate materials made of magnetic metals in the scrap yard.

Exercise 10.1

1. Explain the meaning of the following terms:
 - (a) a magnet.
 - (b) a magnetic substance/material.
 - (c) a non-magnetic material.
 - (d) a ferro-magnetic material.
2. Group the following materials into magnetic and non-magnetic materials: Zinc, paper, aluminium, graphite, steel and plastic.
3. Explain how you can identify the polarity of a magnet whose poles are not marked?
4. Two steel pins were attracted by a magnet. When a south pole was brought in between the two pins, the pins moved further away, as shown in Fig. 10.11. Explain why the pins moved apart.

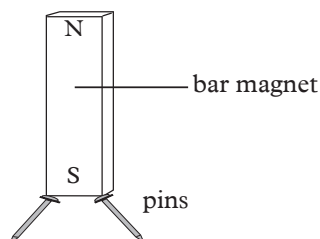

Fig. 10.11: Steel pins attracted to a bar magnet

10.6 Magnetic field pattern around a magnet

Activity 10.9

To investigate the existence of magnetic field around a magnet

(Work in pairs)

Materials: 2 bar magnets, a magnetic compass

Instructions

1. In this activity you will design and carry out an investigation to investigate magnetic field pattern around a magnet.
 - (a) Which direction did the compass needle point? why?
 - (b) What did you observe? Discuss your observation to your class partner.

2. Write a brief procedure for your investigation correctly, execute the procedure and conduct the investigation.
3. Write a report and present it in a class discussion. During the discussion answers the following questions from your class members.
4. How can the investigation be improved?

In Activity 10.9, you should have observed that in steps 2 and 3 when the magnetic compass was placed near the bar magnet, its direction changes. This shows that there is a magnetic effect in the region around the magnet. In this region, there exist magnetic force of attraction and repulsion. This space or region is called **magnetic field**, and is represented by the lines of force called **magnetic field lines**. These field lines form a pattern called **magnetic field pattern**.

10.6.1 Drawing magnetic field pattern round a magnet

Activity 10.10

To investigate magnetic field pattern around a magnet using iron filings

(Work in pairs)

Materials: 2 bar magnets, U-shaped magnet, iron filings, stiff paper

Steps

1. Place a smooth stiff paper on top of a bar magnet.
2. Sprinkle iron filings onto the stiff paper. What happens to the iron filings? Explain your observation to your class partner.
3. Tap the paper gently and draw the pattern displayed by the iron filings.
4. Repeat the activity with north poles of two bar magnets close together and then south to north poles. Observe and draw the pattern displayed by iron filings.
5. Repeat steps 1 to 3 by using a U-shaped magnet.
6. Compare and discuss your patterns with other pairs in your class before presenting your findings to the whole class.

In Activity 10.10, you observed that the iron filings are attracted by the magnet, since there is a magnetic effect in the region around the magnet. The pattern displayed by the iron filings represents the magnetic lines of force.

Fig.10.12 shows the photograph and magnetic field lines of the iron filings arrangement around a bar magnet. Note that the lines do not cross each other.



(a)

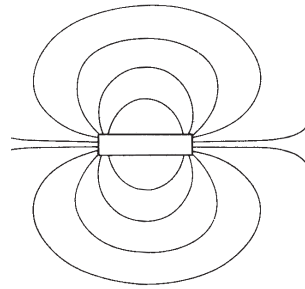

(b)

Fig. 10.12: Magnetic field lines around a bar magnet

When the two north poles or north and south pole are placed close to each other and the steps 1 to 3 repeated, the pattern displayed is as shown in Fig 10.13(a) and (b) respectively.

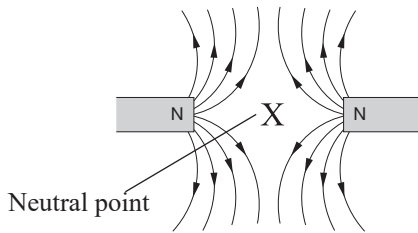

(a)

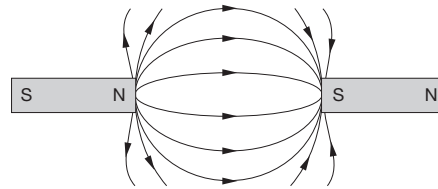

(b)

Fig. 10.13: Magnetic field patterns



Note that magnetic field lines originate from the north pole of a magnet to the south pole.

In step 5 of Activity 10.12, the pattern displayed when the U-shaped magnet was used is as shown in Fig. 10.14.

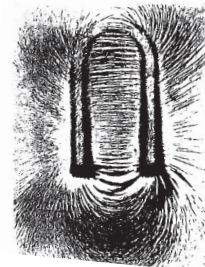

Fig. 10.14: Magnetic field patterns of U-shaped magnet

10.7 Magnetisation and demagnetisation

10.7.1 Structure of an atom

Activity 10.11

To demonstrate the composition of an atom

(Work in groups)

Materials required: A model of an atom, internet, reference books

Steps

1. From the knowledge in Chemistry, tell your group members what an atom is.
2. Draw a diagram of an atom showing the nucleus and electrons. Discuss each part of the atom acknowledging the spinning of electrons around the orbit.
3. Now, using the model provided, show your group members the nucleus, the electrons and the orbit where the electron spins.
4. Hold a discussion on the existence of magnetism in an atom.

In Secondary 1, and in Chemistry we learnt about atoms. An atom is the smallest part of an element that can take part in chemical reactions. In this section we will learn about how atoms take part in magnetism. Magnetism appears to be due to the spinning of electron about the nucleus of an atom. When thinking about magnetism consider the smaller units of an atom have even smaller sub units: protons, neutrons and electrons.

An atom has a nucleus. Around the nucleus there are electrons spinning around it along their orbits.

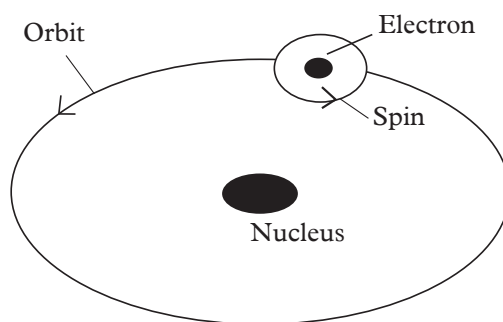

Fig. 10.15: The orbit of a spinning electron about the nucleus of an atom.

10.7.2 Domain theory of magnetism

The domain theory of magnetism developed by a scientist called Wilhelm Weber helps to explain the phenomenon of magnetism.

Activity 10.12

To show the existence of molecular magnets (dipoles)

(Work in groups)

Material: A bar magnet

Steps

1. Cut the the bar magnet provided into two halves. Test the polarities of the ends of each half.
2. Cut one of the halves into two halves and again test the polarities.
3. Continue cutting one piece until you are not able to cut it any more. Each time test the polarity of the halves (Fig. 10.16).

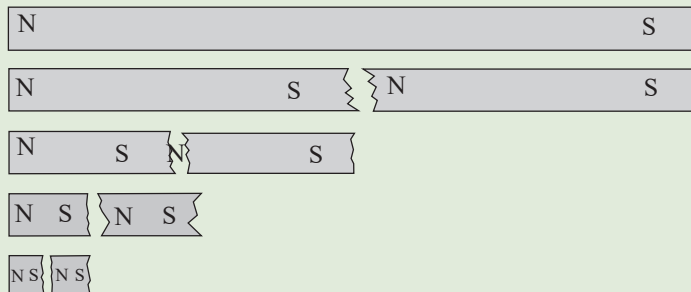

Fig. 10.16: Effects of cutting a bar magnet.

4. Do the small pieces behave like magnets? Why?

The polarity test for the first halves shows that each piece is a magnet in its own right. Further cutting of the pieces still yields a smaller magnet.

The smallest portion of any matter is an atom. Thus if we were able to cut the magnet further we would see that the *smallest magnets*. These small magnets are called *dipoles*. A dipole is the smallest particle of a magnetic material. It is equal to an atom in electric conductor. In ferromagnetic materials these *small magnets* or *dipoles* (with two poles) occupy tiny regions called *domains*. The magnetism of each domain is aligned. However, the domain points are in different and random directions (Fig. 10.17).

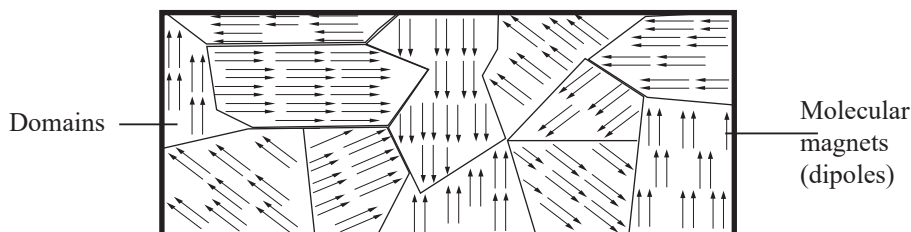

Fig. 10.17: Unmagnetised ferromagnetic material.

The domain theory may be used to explain the processes of magnetisation and demagnetisation. The domain theory states *that inside a magnet there are small regions in which the magnetic direction of all dipoles are aligned in the same directions.*

10.7.3 Magnetisation

Activity 10.13

To find out what magnetisation is

(Work in groups)

Materials: Reference books, internet

Steps

1. Tell your group member what you understand by magnetisation.
2. List to them four method of magnetisation.
3. Now carry a research from Physics reference books and internet to verify your points

Magnetisation is the process of making a magnet from a magnetic materials.

In the second century A.D, Chinese found a method of making magnets by rubbing pieces of common iron against lodestone. Nowadays magnets are made using various methods. Some of these methods include *stroking or touching method, electric method, hammering and induction method.*

(a) Stroking or touching method

(i) Single stroking

A piece of steel e.g. steel needle placed near a magnet becomes magnetised. However, the magnetism acquired usually disappears quickly when the magnet is removed. This magnetism may be enhanced by stroking.

Activity 10.14

To make a magnet by single stroking method

(Work in groups)

Materials: A steel needle, A bar magnet

Steps

1. Place a steel needle on the bench.
2. Stroke the steel needle with the south pole of a bar magnet along the whole length of the steel needle.
3. Once at the end, lift the magnet well away from the steel needle i.e. make a wide sweep as shown in Fig. 10.18.

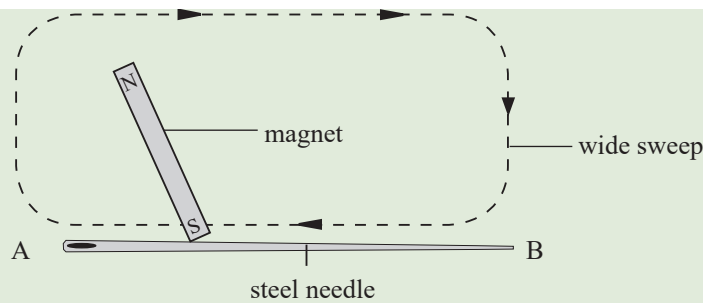

Fig. 10.18: Making magnets by single stroke method.

- Repeat the process in step 2 and 3 several times. Test the polarity of the steel needle by the repulsion method. What is the polarity of end A and B?

The steel needle becomes magnetised with end B becoming a S-pole and end A becoming a N-pole. *Note that the end of the magnetic material last touched by the magnet acquires a polarity opposite to the one touching it.*

(ii) Double stroking

Activity 10.15

To make a magnet by double stroking

(Work in groups)

Materials: A steel needle, two bar magnets

Steps

- Stroke a steel needle using two magnets as shown in Fig. 10.19.
- The stroking should begin at the middle of the steel needle each time making sure that the two bar magnets are lifted far away from the steel needle once you reach the ends.

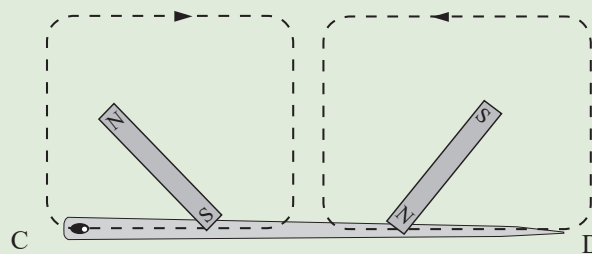

Fig. 10.19: Making magnets by double or divided stroke method.

- Test the polarity at the end of the needle. What is the polarity at the end C and D?
- Suggest another name of this method i.e. double stroking of making a magnet.

It is observed that end C becomes a N-pole while end D becomes a S-pole. The double stroke method is also called the *divided stroke method*.

(iii) Consequent poles

Activity 10.16 To make a magnet with consequent poles

(Work in groups)

Materials: Two bar magnets, A steel pin

Steps

1. Repeat Activity 10.14 as shown in Fig. 10.20 using similar poles in stroking.

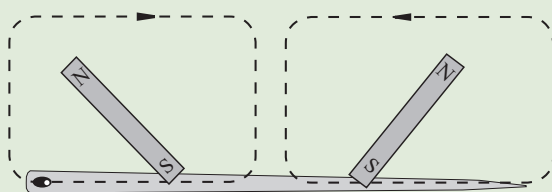

Fig. 10.20: Making a magnet with consequent poles

2. Test for the polarities of the magnet made. What do you notice? Discuss.

Similar poles appear at each end of the steel needle. The middle of the needle becomes a south pole (Fig. 10.21).



Fig. 10.21: Consequent poles

It is possible to have a magnet with like poles on both ends. These are called *consequent poles*.

(b) Electrical method

Activity 10.17 To make a magnet by electrical method

Work in groups

Materials: A wire, a hollow rod, a steel needle, a d.c source

Steps

1. Wind a number of turns around a hollow rod. This is called a *solenoid*. Place a steel knitting needle in the solenoid and pass a direct current (d.c) through the turns of the solenoid as shown in Fig. 10.8.

2. Switch off the current and remove the needle after some minutes. Test for polarity of the needle. What is the polarity of the needle?
3. Repeat the experiment but with the electric current direction reversed. Test for polarity of the needle.

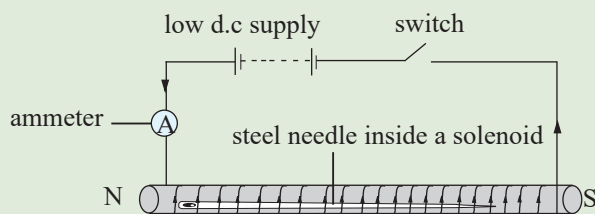

Fig. 10.22: Making a magnet by electrical method.

The steel needle attracts iron fillings after the process.

The polarity of the field is easily seen by examining the path of the conventional current in the coil. If looking at the end of the coil through which current is going clockwise it will produce a **south seeking pole**. A capital 'S' has the ends following the clockwise rotation. Similarly, the other end will be anticlockwise. This produces a **north seeking pole**. A capital 'N' has the ends following anticlockwise rotation.

It is observed that the polarity of the magnet produced depends on the direction of the electric current.

The steel needle is magnetized by electric method.

(c) Hammering method

Activity 10.18 To make a magnet by hammering method

(Work in groups)

Materials: A hammer, a steel bar, iron fillings

Steps

1. Hammer one end of a steel bar fixed in north-south direction several times. (Fig. 10.23).
2. Place the steel bar into ironing filings. What is your observation? Discuss.

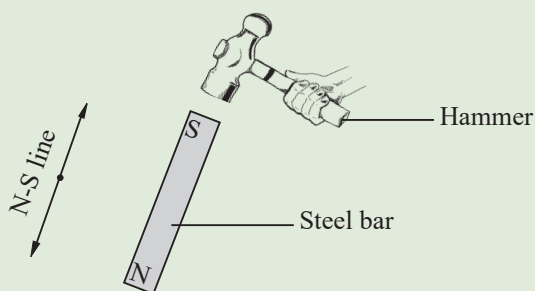

Fig. 10.23: Magnetisation by hammering.

The steel bar attracts iron filings after hammering becoming a weak magnet. The lower end becomes a weak north pole for countries in the northern hemisphere and a south pole for countries in the southern hemisphere. In this method the influence of earth's magnetic field is used to magnetise the steel bar being hammered.

(d) Induction method

Activity 10.19

To make a magnet by induction method

(Work in groups)

Materials: Two bar magnets, Two steel pins

Steps

1. Place a magnet near an unmagnetised steel pin and note what happens. What do you observe?
2. Bring another pin next to the first pin and note what happens.
3. Remove the bar magnet and observe what happens to the second pin.

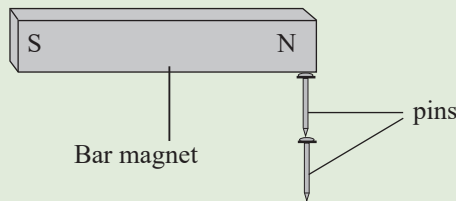

Fig. 10.24: Verifying induction method

4. Separate the first pin from the magnet and note what happens to the second pin.
5. Repeat the activity using two pins placed side by side. Introduce a north pole between the two pins and observe what happens.

When a steel pin is brought near a magnet, the pin is attracted by the bar magnet. The second pin is attracted to the first pin.

It is observed that the second pin falls off when the bar magnet was removed. This shows that the presence of the bar magnet sustains the magnetism between the first and second pin.

The first pin becomes magnetised by the magnet through a process called *induction* and then gets attracted to the magnet. The second pin gets magnetised by the first pin through the same process.

The two pins separate further when a north pole is placed in between them (Fig. 10.25).

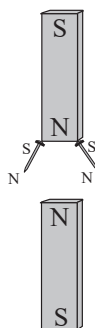

Fig. 10.25: Identifying polarity of the pins

This shows that the induced pole nearest to the magnet is of opposite polarity to that of the inducing magnet.

Induced magnetism is a process in which unmagnetized magnetic material is made a magnet by touching or bringing it near the pole of a permanent magnet. The following activity illustrates magnetic induction.

Activity 10.20 To illustrate magnetic induction

(Work in groups)

Materials: Bar magnet, iron bar, iron filings

Steps

1. Place a magnetic material e.g. iron bar near a bar magnet for some time.
2. Sprinkle some iron filings near one end of the iron bar.
3. Observe what happens on the iron fillings. Discuss.

From Activity 10.20, we notice that after sometime, the magnetic material attracts the iron filings. The magnetic material is magnetized by a permanent magnet by induction. Fig. 10.26 shows magnetic induction of a magnetic material.

Before attraction, the north pole of a magnet repels the north poles of the magnetic dipoles in a magnetic material thereby creating a south pole thereafter attraction occurs as shown below.

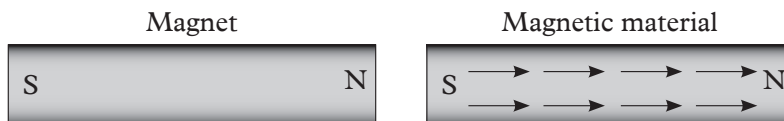

Fig 10.26: Magnetic induction of a magnetic material

Facts about magnetism

Magnetization is the process of making a magnet from a magnetic material.

Since the domains are aligned in all possible directions in an unmagnetised material, the net magnetism in the material is zero. In a partially magnetised material the domains align themselves as shown in Fig. 10.27(a) below. Note that the domains in Fig.10.27(a) are not all aligned in the same direction. When the material is fully magnetised the domain walls move and the molecular magnets align themselves in one particular direction as shown in Fig. 10.27 (b).

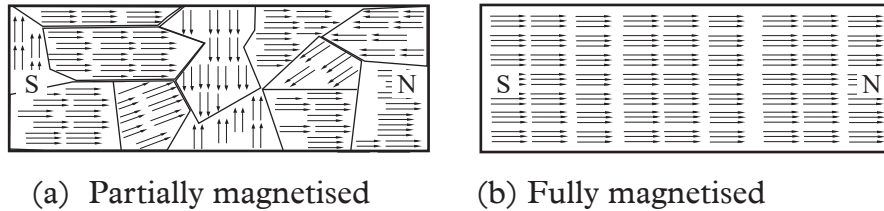

Fig. 10.27: Magnetised ferromagnetic material.

A ferromagnetic material is said to be magnetically saturated when the walls are swept out and the molecular magnets point in the same direction. A resultant north pole is produced at one end and a south pole at the other end as shown in Fig. 10.27(b).

10.7.4 Demagnetisation

(a) Hammering method

Activity 10.21

To demonstrate how a magnet can lose its magnetism

(Work in groups)

Materials: A hammer, A bar magnet, Iron nail

Steps

1. Place a bar magnet in East-West direction and hammer it severally using the hammer.
2. Using the iron nail provided, test whether it can attract the iron vigil. What do you observe? Explain.
3. Tell your members what demagnetisation is and list the methods of demagnetization.

When a bar magnet is placed in East-West direction and hammered severally, it loses its magnetism. The process through which a magnet loses its magnetism is called demagnetisation.

(b) Heating method

Activity 10.22

To investigate demagnetisation of a magnet by heating method

(Work in groups)

Materials: A Bar magnet, source of heat, iron filings

Steps

1. Place a magnet in east-west direction and heat it for some time.
2. Cool it and put iron filings near the magnet. Observe what happens.

From Activity 10.22, we notice the magnet does not attract the iron filings. This is because of demagnetisation of the magnet.

Heating a magnetised material until it becomes red-hot and cooling it suddenly when resting in East-West direction makes it lose its magnetism. This method is called **heating method**.

(c) Electrical method

Activity 10.23

To investigate demagnetization by electrical method

(Work in groups)

Materials: A solenoid, AC supply, A magnetized needle, Iron rod

Steps

1. Placing a magnetised needle in a coil placed in East-West direction and passing an alternating current (a.c) demagnetises the needle (Fig. 10.28).
2. Switch off the current supply and remove the needle from the solenoid. Test its magnetism using iron filings. What do you notice? Explain.

The needle loses its magnetism and thus does not attract the iron rod. Therefore, the needle is demagnetised by **electrical method**

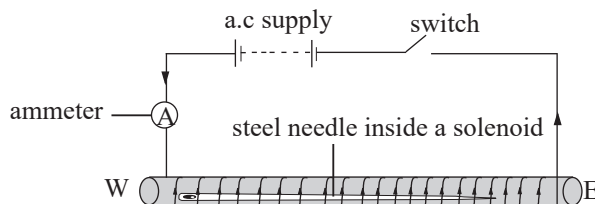

Fig. 10.28: Demagnetisation by electrical method

Facts about demagnetisation

During demagnetisation, the walls of the domain slowly return to their original state with time as this is a more stable state; hence the material becomes demagnetised. This kind of demagnetisation is called *self-demagnetisation*. This is due to the poles at the end which tends to reverse the direction of the molecular magnets. The demagnetisation process can also be influenced externally by giving the molecular magnets enough energy to overcome the forces holding them in a particular direction. The energy may be provided by heating, hammering or dropping on a hard surface or by using an alternating current.

Exercise 10.2

1. State the domain theory of a magnet.
2. Define:
(a) Magnetisation. (b) Demagnetisation. (c) Dipoles.
3. Explain the term induced magnetism.
4. List four methods of making a magnet.
5. Describe how a single stroking is done during making of a magnet.
6. Name two methods of demagnetisation.

10.7.5 Magnetic properties of steel and iron

Magnetic materials are classified according to how well they retain their magnetism once they are magnetised.

Activity 10.24

To distinguish between hard and soft magnetic materials

(Work in groups)

Materials: Four new dry cells, iron filings in two identical dishes, insulated copper wire, switch, two identical iron and steel rods

Steps

1. Make equal turns of the insulated copper wire around the iron and steel rods.
2. Connect the circuit as shown in Figure 10.29. Observe and compare the quantity of iron filings attracted to iron and steel rods. Explain your observation.

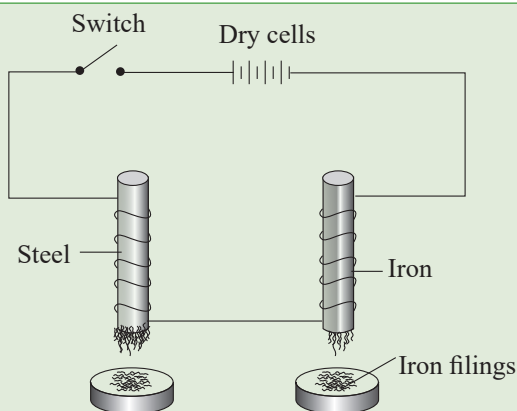

Fig. 10.29: Steel is more retentive than iron

3. Open the switch after a short while and compare the quantities of iron filing left attracted to the iron and steel rods. Explain your observation.

When the switch is closed, iron gets magnetised easily than steel by the electric current (d.c), hence it attracts more iron filings.

When the switch is opened, iron gets demagnetised easily than steel hence drops most of the filings. Steel retains most of iron filings attracted to it.

Iron is easily magnetised or demagnetised. Steel is hard to magnetise than iron but once magnetised it retains its magnetism for a longer time.

10.8 The effect of magnetic materials on the magnetic field

Activity 10.25

To investigate the effect of magnetic materials on the magnetic field

(Work in groups)

Material: Magnets with magnetic keepers, Circular magnet with a shield e.g. that of radio loudspeakers, internet, reference books

Steps

1. Remind your group members the meaning of magnetic field and how to draw them.
2. Draw magnetic field lines when two bar magnets are brought near each other with North pole facing the south pole of the other magnet. What will happen if the soft iron ring is placed in between the bar magnets? Draw the magnetic field.
3. Now, discuss the meaning of magnetic shield and magnetic keepers. In your discussion, point out the importance of magnetic shielding and magnetic keepers. (You may refer to physics reference books or internet).

Magnetic materials affect any magnetic field in the position which it is placed. Fig. 10.30 shows the effect of soft iron in magnetic field.

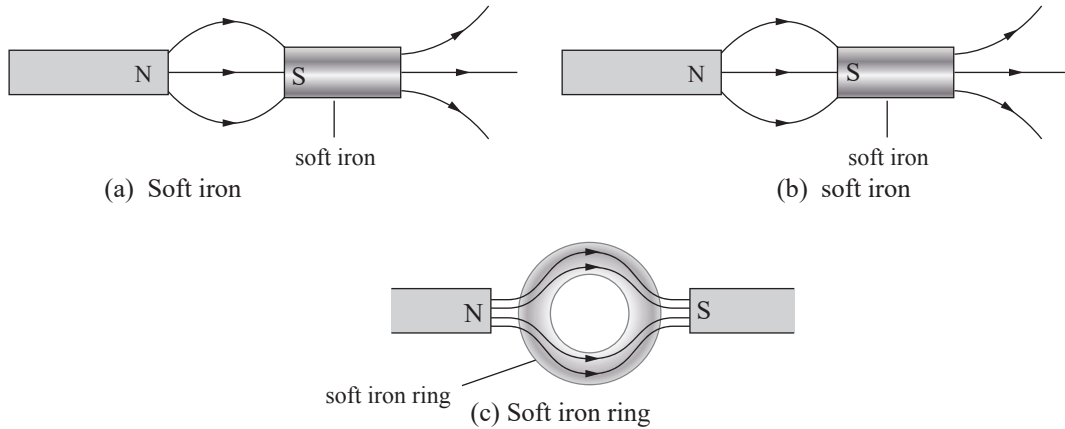

Fig. 10.30: Lines of force concentrate into magnetic materials

The magnetic field lines do not penetrate inside a soft iron ring as shown in Fig. 10.30(c) above. This is why a compass placed inside the ring does not point in any fixed direction. Hence a soft iron ring may be used to shield instruments from magnetic effects.

Magnetic shielding (screening)

Magnetic shielding (screening) is the process that limits the coupling of a magnetic field between two locations. It is done using a sheet of metal, metal mesh, ionized gas or plasma.

Magnetic keepers

Magnetic keepers are bars made from soft iron or steel placed across the poles of permanent magnet to preserve the strength of the magnets.

10.9 Methods of storing magnets

Activity 10.26 To investigate the methods of storing magnets

(Work in groups)

Materials: Magnets with iron keepers, reference books, internet

Steps

1. Take a close look on the magnets with iron keepers provided to you. From the knowledge learnt on magnetic keepers, suggest the function of iron keepers.

2. Suggest other methods of storing magnets.
3. Now carry out a research from physics reference books or internet on methods of storing magnets

(a) Using keepers

A bar magnet loses its magnetism with time due to self-demagnetisation. The process of self-demagnetisation starts at the ends of a magnet in which the free like poles repel each other and slowly upsetting the alignment of the molecular magnets inside it. To minimise this, soft iron bars called *keepers* are placed across their ends as shown in Fig. 10.31. The dipoles find themselves in a closed chain or loops round the magnet and the keepers, with no free poles, available to upset the domains. The soft iron keepers are used since they are easily magnetised by induction method.

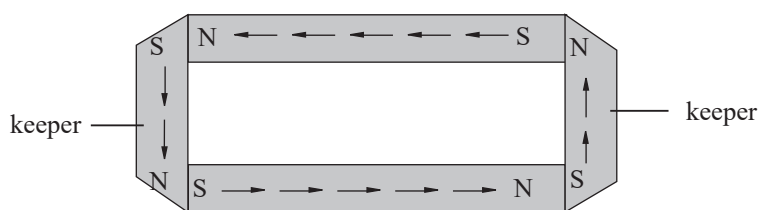

Fig. 10.31: Soft iron keepers used to store magnets.

(b) Storing magnets away from heat and metal objects

Heat can cause poles of the atoms in a magnet to randomize and this will eventually destroy a magnet. It is therefore, recommended to store magnets in a cool place, in room temperature and out of the sun. Weak magnets will easily be ruined by stronger magnets and electromagnetic field so you must make sure to keep them out of touch with other stronger magnets.

(c) Keeping magnets out of reach of children

Magnets are extremely dangerous to swallow and therefore should be stored far away from the reach of kids or pots. Just like you store medicine high up or behind lock, you need to do the same with magnets. Especially for magnetic jewelry that looks attractive to play with. Children might also have magnets as toys and it is therefore important parents to teach them how to store the magnets properly.

(d) Protecting magnets against mechanical shocks

Many magnets can lose their magnetism through improper storage. It is important to understand how to store magnets if you want to prolong their life time. Don't throw the magnets to the storage box but rather place them gently. Avoid striking them with a hammer or any other material. It will lose its magnetism or even crack and break.

Uses of magnets

As learnt in Activity 10.14, electromagnets are made from soft magnetic materials e.g. iron. The following are some of the uses of magnets.

1. Magnets are widely used in electric and electromechanical devices such as electric ball, motors, generators, in transformers, relays, magnetic lifts in industries to lift heavy metals in a microwave oven in kitchen etc.
2. The most important use of magnets is the magnetic compass that is used to find the geographical directions.
3. They are also used in the speakers that can convert the electrical energy into sound energy.
4. They are used in the electrical bells.
5. They are also used to sort out the magnetic and non magnetic substances from the scrap.
6. They are used in TV screens, computer screens, telephones and in tape recorders.
7. They are used in the candy or cold drink vendors to separate the metallic cap from the lots.
8. They are used in cranes.
9. They are used in the refrigerators to keep the door close.
10. They are used in the Maglev trains. In the Maglev trains, the super conducting magnets are used on the tracks on which the train floats. These types of the trains are working on the repulsion force of the magnets.

Topic summary

- A **magnet** is a piece of metal with either natural or induced properties of attracting other metal objects.
- Materials which are attracted by a magnet are called *magnetic materials* while those which are not attracted are called *non-magnetic materials*.
- The ends of a magnet where the attraction is strongest are known as the magnetic poles. There are two types of poles. **North pole** and **south pole**.
- Unlike poles attract each other while like poles repel each other. This is called the *basic law of magnetism* or *the first law of magnetism*.
- Repulsion is the only sure way of testing for polarity of a magnet.
- The space or region around a magnet is called **magnetic field**. It is represented by the lines of force called **magnetic field lines**.
- **Magnetism** is due to the spinning of electrons about the nucleus of an atom.
- Domain is tiny regions in a magnetic material that is occupied by the dipoles.
- Dipole is the smallest particle of a magnetic material. It is equal to an atom in electric conductor.
- **Domain theory** states that inside a magnet there are small regions in which the magnetic direction of all dipoles are aligned in the same direction.
- **Magnetisation** is the process of making a magnet from a magnetic materials.
- The methods of magnetization include:
 1. Stroking method.
 2. Electrical method by passing a.c current.
 3. Hammering method where a magnetic material is hammered facing N-S direction.
 4. Induction method.
- **Demagnetisation** is the process through which a magnet loses its magnetism.
- The method of demagnetization include:
 1. Heating a magnet till red-hot and cool it suddenly while facing East-West direction.
 2. Hammering a magnet while facing East-West direction.
 3. Electrical method by passing AC current.
- Magnetic keepers are used to store magnets. They help to preserve the strength of the magnets by completing the magnetic circuit.

Topic Test 10

1. State two properties of a magnet.
2. State the basic law of magnetism.
3. Name *four* types of magnets according to shapes.
4. Describe an experiment to explain the existence of magnetic poles.
5. Explain what would happen to a U-shaped magnet if it is freely suspended as shown in Fig. 10.32 below.

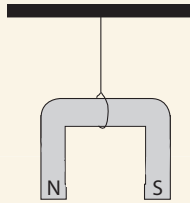

Fig. 10.32: U-shaped magnet

6. What is the main difference between a ceramic magnet and a bar magnet?
7. You have been provided with the following;
 - (a) a rod labelled S, which is a magnetic material.
 - (b) a rod labelled N, which is a non-magnetic material.Explain how you would identify them.
8. The magnets shown in Fig. 10.33, pole B attracts pole P and pole Q attracts pole X. If pole Y is South pole:.



Fig. 10.33: Bar magnet

- (a) What is the polarity of P?
 - (b) What would happen if the following poles are brought close together:
 - (i) pole B and X
 - (ii) pole A and pole Q
 - (iii) pole B and pole Y
 - (c) Draw a magnetic field pattern when pole B and P are placed near each other.
9. Define the following:
 - (a) Dipole
 - (b) Domain theory
 - (c) Self-demagnetisation
 - (d) Consequent poles

- 10.** Differentiate between a magnet and magnetic material using the domain theory.
- 11. (a)** Explain the following terms using domain theory of magnetisation
- (i)** Magnetisation
 - (ii)** Demagnetisation
- (b)** Explain three methods of magnetising and demagnetising magnetic materials and a magnet respectively.
- 12.** Fig. 10.34 shows what is observed when two steel pins AB and CD, hang from the north pole of a magnet.

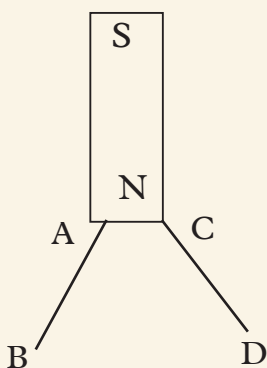

Fig. 10.34

- (a)** Explain why the distance BD is greater than AC.
 - (b)** State the polarity of ends B and D.
 - (c)** Explain what is meant by magnetic induction.
- 13.** With the aid of a diagram, explain how bar magnets are stored so as to minimize self-demagnetisation.
- 14.** Using the domain theory of magnetism, explain why.
- (a)** The strength of a magnet cannot be increased beyond a certain point.
 - (b)** The temperature increase weakens or destroys the magnetism of a magnet.
- 15.** Describe all experiment to show how to make a magnet by
- (a)** Single stroke method
 - (b)** Electrical method
- 16.** Discuss three applications of magnets in our society today.



South Sudan

Secondary Physics 2

Student's Book

Secondary Physics has been written and developed by Ministry of General Education and Instruction, Government of South Sudan in conjunction with Subjects experts. This course book provides a fun and practical approach to the subject of Physics, and at the same time imparting life long skills to the students.

The book comprehensively covers the Secondary 2 syllabus as developed by **Ministry of General Education and Instruction.**

Each year comprises of a Student's Book and teacher's Guide.

The Student's Books provide:

- Full coverage of the national syllabus.
- A strong grounding in the basics of Physics.
- Clear presentation and explanation of learning points.
- A wide variety of practice exercises, often showing how Physics can be applied to real-life situations.
- It provides opportunities for collaboration through group work activities.
- Stimulating illustrations.



All the courses in this secondary series were developed by the Ministry of General Education and Instruction, Republic of South Sudan. The books have been designed to meet the secondary school syllabus, and at the same time equipping the students with skills to fit in the modern day global society.

This Book is the Property of the Ministry of General Education and Instruction.

This Book is not for sale.

Any book found on sale, either in print or electronic form, will be confiscated and the seller prosecuted.

Funded by:



Published by:

