



South Sudan



# Secondary Chemistry 4

Student's Book

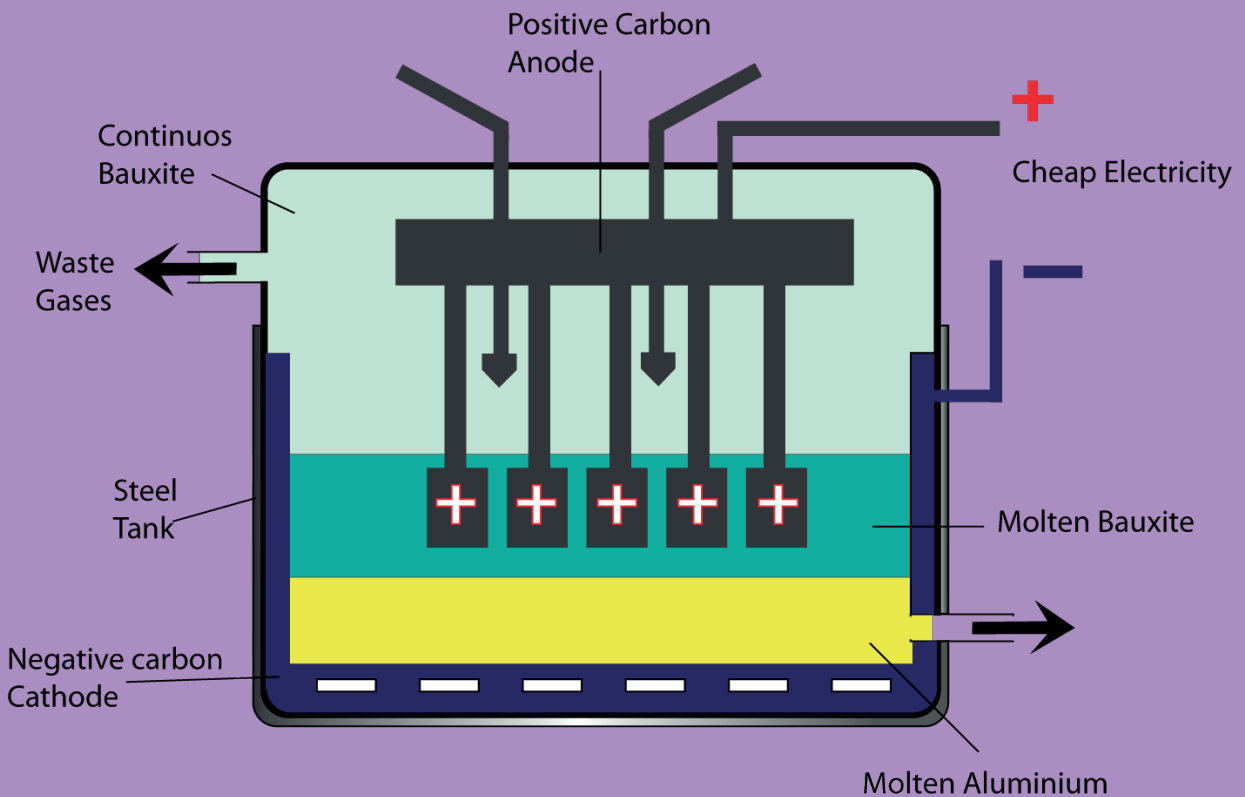

This Book is the Property of the  
Ministry of General Education  
and Instruction.

**This Book is not for sale.**

Funded by:



## **How to take care of your books.**

### Do's

1. Please cover with plastic or paper. (old newspaper or magazines) Please make sure you have clean hands before you use your book. Always use a book 2. marker do not fold the pages.
3. If the book is damaged please repair it as quickly as possible. Be careful who you lend your schoolbook to.
4. Please keep the book in a dry place.
5. When you lose your book please report it immediately to your teacher.

### Don'ts

1. Do not write on the book cover or inside pages.
2. Do not cut pictures out of the book.
3. Do not tear pages out of the book.
4. Do not leave the book open and face down.
5. Do not use pens, pencils or something thick as a book mark.
6. Do not force your book into your schoolbag when it is full.
7. Do not use your book as an umbrella for the sun or rain.
8. Do not use your book as a seat.

South Sudan

SECONDARY

4

# Chemistry

## Student's Book 4



This book is the property of the Ministry of  
General Education and Instruction.

Funded by:



**THIS BOOK IS NOT FOR SALE**

Published in 2018 by:

Longhorn Publishers (K) Ltd.,  
Funzi Road, Industrial Area,  
P.O. Box 18033 – 00500,  
Nairobi, Kenya.

©2018, THE REPUBLIC OF SOUTH SUDAN, MINISTRY OF GENERAL  
EDUCATION AND INSTRUCTION.

All rights reserved. No part of this book may be reproduced by any means graphic, electronic, mechanical, photocopying, taping, storage and retrieval system without prior written permission of the Copyright Holder.

Pictures, illustrations and links to third party websites are provided in good faith, for information and education purposes only.



## Table of Contents

<b>Unit 1 Ions and Gases.....</b>	<b>1</b>
1.1 Identification of ions.....	1
1.2 Identification of gases.....	9
<b>Unit 2 Energy changes in chemical reactions.....</b>	<b>11</b>
2.1 Heat of reactions.....	11
2.2 Exothermic and endothermic reactions .....	12
2.3 Energy profile diagrams.....	15
2.4 Bond breaking and bond formation .....	17
2.5 Calculating enthalpy changes using bond energies .....	19
2.6 Activation energy and their energy level diagrams .....	31
<b>Unit 3 Chemical Kinetics, Equilibrium and Electrochemistry .....</b>	<b>33</b>
3.1 The Collision Theory and Activation Energy ( $E_a$ ) Theory .....	34
3.2 Determining of the rate of chemical reaction.....	36
3.3 Factors affecting rates of reaction.....	37
3.4 Chemical equilibria .....	51
3.5 Electrochemistry .....	60
3.6 Role of electricity in electrolysis .....	69
3.7 Role of water in electrolysis .....	71
<b>Unit 4 Composition of ores of some common metals and appropriate methods of extraction .....</b>	<b>72</b>
4.1 Sodium .....	76
4.2 Aluminium.....	79
4.3 Copper .....	84
4.4 Iron.....	88
4.5 Zinc .....	92
4.6 Chromium .....	96
4.7 Properties of metals.....	98
<b>Unit 5 Analytical techniques and method of determining of structures.....</b>	<b>102</b>
5.1 Chromatography .....	103
5.2 Infrared spectroscopy.....	109
5.3 Nuclear magnetic resonance .....	112
5.4 Ultra violet spectroscopy.....	115
5.5 Mass spectroscopy .....	116

<b>Unit 6 Organic chemistry</b> .....	<b>119</b>
6.1 Hydrocarbons .....	121
6.2 Alkanes .....	121
6.3 Alkenes.....	136
6.4: Alkynes.....	149
6.5 Alkanols (Alcohols) .....	160
6.6 Alkanoic acid.....	163
6.7 Detergents .....	175
6.8 Polymers and fibres.....	188
6.9 Alkanals and Alkanones.....	200
6.10 Organic compounds .....	213
<b>Unit 7 Introductio to Nuclear chemistry</b> .....	<b>216</b>
7.1 Types of radiations .....	217
7.2 Nuclear fission and nuclear fusion .....	220
7.3 Rate of decay .....	223
7.4 Applications of radioactivity in medicine.....	224
<b>Glossary</b> .....	<b>226</b>
<b>Appendix I</b> .....	<b>233</b>
<b>Appendix II</b> .....	<b>234</b>

### Learning outcomes

Knowledge and understanding	Skills	Attitudes
<ul style="list-style-type: none"> <li>Understand the procedures to test, identify and describe the ions.</li> <li>Understand the procedures and reagents used in identification of ions.</li> </ul>	<ul style="list-style-type: none"> <li>Design and carry out practical investigations using aqueous sodium hydroxide and aqueous ammonia to identify and describe the cations.</li> <li>Use procedures to test, identify and describe the anions.</li> </ul>	<ul style="list-style-type: none"> <li>Appreciate the importance of ions in the understanding of chemistry.</li> </ul>

## Introduction

Identification of ions is a very important study in Chemistry. Sometimes, we may need to find out the identity of a compound or a gas we are dealing with. For example, the standardisation bureaus in every country always must confirm if what the manufacturer says is contained in a substance (product) is truly the case. How do such organisations do the verifications? They achieve this by carrying out chemical analysis. Chemists do this by conducting careful systematic tests using standardised procedures.

### 1.1 Identification of ions

#### Activity 1.1

- In groups, name some of the coloured salts you may come across in the Chemistry laboratory.
- Your teacher will provide you with samples of these salts. Examine them carefully. Are there any other differences in their properties apart from the colour? Can you correctly identify the salts by their appearance only? Explain your answer.

## The Facts

Identification and tests for ions and gases form the elementary qualitative analysis. It involves making careful observations drawing appropriate conclusions and inferences based on correct chemical knowledge.

There are two kinds of ions present in ionic compounds, that is positively charged ions and the negatively charged ions. The positively charged ions are called **cations**. The negatively charged ions are called **anions**.

### (a) Tests for cations

#### Discussion corner!

What are cations and where do you think they derive their name from? Give four examples of cations. How can we test for cations?

## The Facts

Cations show characteristic reactions with the common test reagents. These reagents are aqueous sodium hydroxide and aqueous ammonia solutions. Some cations form precipitates of specific colours. Others show interesting behaviour when reacted with the reagents in excess. However, these tests or analysis at this level are considered as preliminary tests. This is because they could be need to conduct further tests for precise identification of specific ions, often done in advanced chemical laboratories.

### Measures when carrying out qualitative analysis

When carrying tests for ions, the following must be taken into consideration for successful qualitative analysis.

- Utilise your skills in correctly manipulating the apparatus to make correct observations and logical conclusions.
- Adhere to the procedure strictly. Omission, shortcuts or alterations of instruction will lead to wrong observations and hence wrong conclusions.
- Do not mix or contaminate substances supplied for qualitative analysis. Contamination of a reagent may spoil an experiment. Droppers once used should be returned to their original reagent bottles or beakers.
- If you feel, during normal practical session, that you can make a logical improvement, on the method suggested, draw it to the attention of the teacher.
- When working in small groups, ensure that you are involved in performing the experiment. Assist other learners with difficulty in handling the apparatus, i.e.
  - (i) Tell the colour observed for students with poor eyesight.
  - (ii) Work on lower benches that are easily reachable by physically challenged students.

- Do not smell gases directly. The best way to do this is to hold the gas source about 15-20 cm away from you and blow the gas towards the nose with your palm, then sniff carefully.

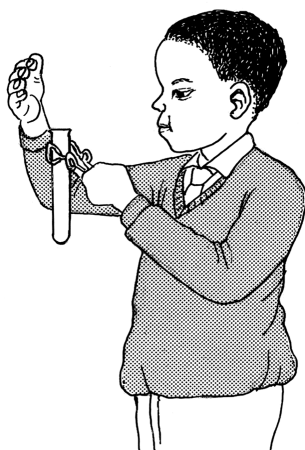

*Fig 1.1: Wafting the gas to smell it*

### *Use of sodium hydroxide to test for cations*

#### Activity 1.2

##### **In groups**

##### **To test presence of cations using aqueous sodium hydroxide**

##### **Apparatus**

Nine test tubes, test tube rack, dropper, spatula, labels.

##### **Reagents**

Aluminium sulphate, calcium nitrate, copper (II) sulphate, iron (II) sulphate, iron (III) chloride, lead nitrate, zinc nitrate, aqueous sodium hydroxide and distilled water.

##### **Procedure**

- Using a clean spatula, scoop about a quarter spatulaful of aluminium sulphate and put it into a test tube.
- Add about 10 cm<sup>3</sup> of distilled water into the contents of the test tube. Shake until all the solid dissolves. Label this solution as Al<sup>3+</sup>.
- Take about 1 cm<sup>3</sup> of the solution and put into a test tube. Add two drops of aqueous sodium hydroxide to the contents of the test tube and then record your observations.
- Add more drops of sodium hydroxide solution until in excess. Record your observations.

5. Repeat the procedure above for the rest of the salts, each in turn and complete the table below.

**Table 1.1: Test results for presence of cations using NaOH(aq)**

Cation	A few drops of aqueous NaOH	Excess of aqueous NaOH
Al <sup>3+</sup>		
Ca <sup>2+</sup>		
Cu <sup>2+</sup>		
Fe <sup>2+</sup>		
Fe <sup>3+</sup>		
Pb <sup>2+</sup>		
Zn <sup>2+</sup>		

### *Use of aqueous ammonia to test for cations*

#### Activity 1.3

##### **In groups**

##### **To test presence of cations using aqueous ammonia**

Repeat the procedure in Activity 1.2 using aqueous ammonia in place of sodium hydroxide and fill in the table below.

**Table 1.2: Test results for cations using NH<sub>4</sub><sup>+</sup>(aq)**

Cation	A few drops of aqueous NH <sub>4</sub> <sup>+</sup>	Excess of aqueous NH <sub>4</sub> <sup>+</sup>
Al <sup>3+</sup>		
Ca <sup>2+</sup>		
Cu <sup>2+</sup>		
Fe <sup>2+</sup>		
Fe <sup>3+</sup>		
Pb <sup>2+</sup>		
Zn <sup>2+</sup>		

#### **Discussion corner!**

1. Identify cations that formed coloured precipitates with a few drops of aqueous NaOH and aqueous ammonia.
2. Identify the cations that dissolved in excess of NaOH. Why do you think they dissolved?
3. Identify the cations that dissolved in excess of aqueous ammonia. Why do you think they dissolved?
4. Did you use dilute or concentrated solutions of NaOH and ammonia? Give reasons for the use of this level of concentration.

5. What do you think will happen when you use cold or warm solutions of NaOH and ammonia? Explain your answer.
6. What is a precipitate? Why are the precipitates formed?

### *The Facts*

On addition of few drops of NaOH, the cations form precipitates which are metal hydroxides. The coloured precipitates include; copper (II) ions, iron (II) ions, iron (III) ions which are blue, green and brown respectively. On addition of excess sodium hydroxide, none of the coloured precipitates dissolves. The cations that form white precipitates in a few drops of NaOH are aluminium ions, calcium ions, lead (II) ions and zinc (II) ions. Aluminium, zinc and lead ions dissolve in excess of sodium hydroxide to form colourless solutions.

When a few drops of aqueous ammonia are added only calcium ions do not form a precipitate. The rest of the ions form precipitates with the same colour as in the case of aqueous NaOH. However, when excess ammonia is added, copper (II) ions dissolve to form a deep blue solution while zinc ions dissolve to form a colourless solution. The rest of the ions do not dissolve in excess of aqueous ammonia.

### **(b) Test for anions**

#### **Discussion corner!**

1. What are anions? Give five examples of anions.
2. What is the precipitation reaction? How can you use precipitation reactions to identify specific salts?

## Activity 1.4

### Investigating solubility of salts in water

#### *Apparatus*

Seven test tubes, spatula.

#### *Reagents*

Sodium carbonate, lead carbonate, lead sulphate, lead nitrate, barium sulphate, barium chloride and lead (II) chloride.

#### *Procedure*

1. Scoop a spatula endful amount of sodium carbonate and put it into a test tube.
2. Add water to the salt, stir and make observations.
3. Repeat the procedure for the rest of the salts.

## The Facts



In general:

- All nitrates are soluble.
- All chlorides are soluble except, lead (II) chloride and silver chloride.
- All sulphates are soluble except barium sulphate, lead (II) sulphate and calcium sulphate. Calcium sulphate is sparingly soluble in hot water.
- All sulphites are soluble except barium sulphite, calcium sulphite and lead sulphite.
- All carbonates are insoluble except those of sodium, potassium and ammonium.
- All hydrogencarbonates are soluble.
- All hydrogensulphates are soluble.
- All bases are insoluble except those of: potassium hydroxide, sodium hydroxide and ammonium hydroxide.

## Activity 1.5

### To test for presence of anions in compounds

#### *Apparatus*

Test tubes, source of heat, filter paper, spatula.

#### *Reagents*

Distilled water, solids of: sodium carbonate, sodium chloride, potassium iodide, sodium nitrate and sodium sulphate; calcium hydroxide solution, solids of: sodium sulphite, lead (II) nitrate, 2M nitric acid, aluminium foil, silver nitrate, barium nitrate and acidified potassium dichromate.



## Procedure

Table 1.3: Investigating presence of anions in compounds

Anion	Procedure	Observations
Carbonate	Add dilute nitric acid to the solid. Pass any gas produced through calcium hydroxide solution.	
Chloride	Disolve the solid. Add dilute nitric acid to aqueous chloride solution, then followed by three drops of silver nitrate.	
Iodide	Put about 5 cm <sup>3</sup> of iodide solution in a test tube. Add 3 drops of nitric acid, followed by three drops of lead (II) nitrate solution.	
Nitrate	Add 2 cm <sup>3</sup> of sodium hydroxide to a little nitrate solution, drop aluminium foil into the solution and warm it gently. Test the gas produced with damp red litmus paper.	
Sulphate	To 2 cm <sup>3</sup> of sulphate solution in a test tube, add 2 cm <sup>3</sup> of dilute nitric acid, followed by barium nitrate solution.	
Sulphite	To 2 cm <sup>3</sup> of sulphite solution in a test tube add 2 cm <sup>3</sup> of nitric acid and test gas produced using a filter paper dipped in potassium dichromate.	

### The Facts

Carbonates react with dilute nitric or hydrochloric acid to produce carbon dioxide which is observed as effervescence and reacts with calcium hydroxide to form a **white precipitate or milky of calcium carbonate i.e, an insoluble salt**. Chlorides on the other hand react with acidified silver nitrate to form a **white precipitate of silver chloride**. Lead (II) nitrate reacts with iodine salts to form a **yellow precipitate (lead (II) iodide)**. All soluble lead salts will react with soluble iodide salts to form a **yellow precipitate**. This is the confirmation test for presence of iodide ions.

Nitrates react with aluminium metal in the presence of a warm alkali to produce a gas which turns moist red litmus paper blue. Note that nitrate ions are always reduced to ammonia gas ( $\text{NH}_3$ ), which is responsible for the observations made. For sulphates and sulphites they react with acidified lead (II) nitrate, forming a **white precipitate** which confirms the presence of sulphate ions; but if the precipitate further dissolves to form a **colourless solution**, we test the gas produced using acidified potassium dichromate filter. If the gas turns the filter paper from orange to green it confirms the presence of sulphite ions.

### Discussion corner!

1. Write ionic equations for the test reactions for the anions tested in Activity 1.5 above.
2. Briefly explain why different specific reagents were used in test identification for each anion unlike in tests for cations.
3. Give reasons why most of test solutions are acidified.
4. Name the gas responsible for turning acidified potassium dichromate filter paper from orange to green.

### Check your progress 1.1

1. A sample of water is suspected to contain sulphate ions but not chloride ions. Describe how you can confirm the presence of sulphate ions in the water sample.
2. During a laboratory session a student accidentally removed pieces of label on two sets of colourless solutions. One of the solutions was lead (II) nitrate while the other one was aluminium sulphate. Describe how would you assist the student to identify the solutions.
3. Which anions are identified using the following solutions?
  - (i) Silver nitrate
  - (ii) Barium nitrate

## 1.2 Identification of gases

**CAUTION:** Experiments involving chlorine and sulphur dioxide should be carried out in a fume chamber since they are poisonous and air pollutants as well.

### Activity 1.6

#### To carry out identification tests for different gases

##### *Apparatus*

Litmus papers, boiling tubes, wooden splints, filter papers, source of heat, gas jars, delivery tubes, troughs, clamps, etc.

##### *Reagents*

Ammonium chloride, solid sodium carbonate, lime water, potassium manganate (VII), dilute hydrochloric acid, zinc granules, hydrogen peroxide, distilled water, sodium sulphite and manganese (IV) oxide.

##### **Procedure**

1. Prepare the gases using suitable laboratory methods learnt in previous classes.
2. Then carry out tests for each as indicated in the table below.
3. Record your results in a table like the one shown below.

**Table 1.4:** Investigating identification test for different gases

Gas	Procedure	Observations
Ammonia	Hold a moist red litmus paper in a gas jar containing the gas.	
Carbon dioxide	Bubble the gas produced through lime water.	
Chlorine	Hold moist red and blue litmus papers at the mouth of the gas jar containing chlorine gas.	
Hydrogen	Introduce a burning splint into the gas jar containing the gas.	
Oxygen	Introduce a glowing splint into a gas jar containing of the gas.	
Sulphur dioxide	Insert a filter paper soaked in acidified potassium dichromate into a gas jar containing the gas.	

### Discussion corner!

1. Briefly explain the properties of the gases responsible for the observations made in each case in Activity 1.6.
2. Write the chemical equation for the reaction tests for the following gases:
  - (a) carbon dioxide
  - (b) chlorine
  - (c) sulphur dioxide

### The Facts

Ammonia gas is basic and therefore turns moist red litmus paper blue. It is the only common known basic gas. It also forms a white smoke of ammonium chloride when hydrogen chloride gas from concentrated hydrochloric acid is held near it. Carbon dioxide reacts with lime water (calcium hydroxide) forming a white precipitate of calcium carbonate. Chlorine gas is a pale green gas with a choking smell and turns a blue litmus paper red then bleaches it white. Hydrogen gas is colourless odourless gas that burns with a 'pop' sound. Oxygen is a colourless odourless gas that relights a glowing splint. Sulphur dioxide is a colourless gas with a pungent smell that turns acidified potassium dichromate from orange to green.

### Check your progress 1.2

1. A student came across unlabelled colourless gas in the laboratory. She suspected the gas to be carbon dioxide gas. Briefly describe the test procedure she can use to confirm that the gas is carbon dioxide.
2. A glass rod dipped in concentrated hydrochloric acid was placed at the mouth of a test tube containing gas Y. A ring of white fumes was formed. What conclusion could be made about this investigation? Write the equation for the reaction that took place.

### Learning outcomes

Knowledge and understanding	Skills	Attitudes
<ul style="list-style-type: none"> <li>Understand energy changes in chemical reactions.</li> </ul>	<ul style="list-style-type: none"> <li>Design/plan an investigation, select techniques, apparatus and materials to determine heat of reactions.</li> <li>Calculate heat of reactions.</li> <li>Represent energy changes by energy profile diagrams.</li> </ul>	<ul style="list-style-type: none"> <li>Appreciate the importance of energy change in understanding chemistry.</li> </ul>

### Introduction

During a cold night in a scouting camp, the scouts sit around a fire. The fire keeps them warm. Why and how does the fire keeps them warm?

On the other hand when sportspersons are injured, an ice-cold pack is quickly put around the injured area. It temporarily relieves the pain as they seek further medical assistance. Why do you think this is so? In the above mentioned cases, there are energy changes involved that bring about the outcomes.

- How do you measure energy changes in Chemical reactions?

### Group Task

In pairs, using your previously acquired knowledge;

- Define a chemical reaction. Differentiate between a chemical change and physical process.
- Mention some reactions performed in the school laboratory that involved heat evolution or temperature rise. Was there any experiment that you witnessed fall in temperatures? What do you think caused these temperature changes?
- Briefly discuss some of the forms of energy you are aware of. Heat is considered as a form of energy, explain why.

### 2.1 Heat of reactions

Most chemical reactions are accompanied by changes in energy (heat energy). In chemistry the energy change is referred to as **enthalpy change**. Some reactions give out heat while others absorb heat during the processes.

The following reactions are accompanied by heat evolution.

- i. Reaction of sodium metal with water.
- ii. Mixing small quantity of concentrated sulphuric acid with water.

Haber process and Contact process are some of the industrial activities releasing large amount of heat to the surrounding.

Heat changes are of great importance to chemists in most chemical processes. They have effect on the optimum yield of desired products.

### *Group Task*

In pairs,

1. Using a thermometer, take the body temperatures of your colleague. Now using the back of your palm, feel the body temperature. Do you consider this temperature to be normal body temperature?
2. Explain why the temperature of a patient is normally measured during hospital visits before treatment.
3. Discuss how temperature changes affect:
  - (i) Storage and transportation of flammable petroleum products.
  - (ii) Inform farmers' decision in choosing what crop to plant in certain periods of the year. You may need to explain how temperature changes influence the sweetness of citrus fruits, pineapples, as well as crop growth rate.

You should now appreciate how heat changes in a person's body is critical to their good health, and how heat changes influence number of decisions in our everyday's life. It also concerns chemists to know the amount of energy changes during a reaction because it is useful in many aspects.

## **2.2 Exothermic and endothermic reactions**

The word exothermic describes a process that releases energy in the form of heat to surroundings. Exothermic reactions are usually hot because they produce heat energy. Endothermic reaction describes a process that absorbs energy in the form of heat from the surroundings. Endothermic reactions usually feel much colder as it progresses because it is absorbing heat from the surroundings.

In classifying a process or reaction as exothermic or endothermic, one considers how the surroundings temperature change. An exothermic reaction is one that releases heat and causes the surroundings temperature to rise while an endothermic reaction is one that absorbs heat and causes the surroundings temperature to fall.

### *Individual Task*

Classify the following processes as either exothermic or endothermic reaction.

- |                                     |                                   |
|-------------------------------------|-----------------------------------|
| (i) Burning of charcoal             | (vii) Baking of bread             |
| (ii) Dissolving of ammonium nitrate | (viii) Decomposition of limestone |
| (iii) Melting of ice                | (ix) Formation of ice cubes       |
| (iv) Evaporation of water           | (x) Combustion of fuels           |
| (v) Neutralisation reaction         | (xi) Respiration                  |
| (vi) Photosynthesis                 |                                   |

The following class activities will help us to understand more about energy changes in different processes.

### Activity 2.1

*To observe heat or temperature changes during reactions*

#### **Apparatus and chemicals**

- Boiling tubes
- 10 cm<sup>3</sup> measuring cylinder
- Concentrated sulphuric acid
- Ammonium nitrate
- Distilled water

#### **Procedure I**

1. Put 10 cm<sup>3</sup> of water into a boiling tube. Feel the boiling tube with your palm. Is it cold or hot?
2. Carefully and slowly add 2 cm<sup>3</sup> of concentrated sulphuric acid to the boiling tube sliding it along the tube.
3. Touch and feel the boiling tube. How does it feel, hot or cold?
4. Suggest reasons for these temperature changes observed.

#### **Procedure II**

1. Pour 10 cm<sup>3</sup> of water into a boiling tube. Touch and feel the tube. How does it feel?
2. Add 4 g of ammonium nitrate into the boiling tube. Stir gently using glass rod until it all dissolves as you feel the boiling tube with your palms.

3. Describe the changes in the hotness or coldness before and after adding ammonium nitrate.

### Activity questions

1. Classify the reactions investigated in activity 2.1 as either exothermic or endothermic. What informed your reasons?
2. What do you think bring about these temperature changes?
3. Describe the surroundings for the activities above.

## Activity 2.2

### To investigate exothermic and endothermic reactions

Using hints from activity 2.1, design an experiment to investigate whether the following reaction is exothermic or endothermic.

1. Dissolving potassium nitrate in water.
2. Dissolving sodium hydroxide in water.

**Caution:** Sodium hydroxide pellets are highly corrosive. Ensure they do not come into contact with your skin or clothes.

### Activity questions

1. Record your temperature readings in a table like the one shown below.

Specimen	Initial temperature of water ( $^{\circ}\text{C}$ )	Final temperature of the solution ( $^{\circ}\text{C}$ )
Potassium nitrate solution		
Sodium hydroxide solution		

2. Classify the reactions as exothermic or endothermic.
3. Describe the system and surrounding for each reaction.
4. Illustrate diagrammatically heat loss and heat gain into the system.
5. What informed your choice of container to use in the two experiments i.e. whether to use a beaker, test tube or boiling tube?
6. While measuring and recording the temperatures, there are a number of assumptions made. One such is the thermometer did not absorb any significant amount of heat. Give other assumptions you are likely to have made.

### The Facts

The system refers to the apparatus used, its content and anything touching the solutions while the surrounding is everything else around it.



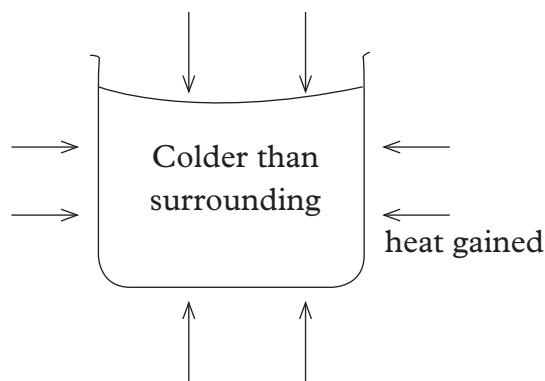

**Fig 2.1: Endothermic reaction**

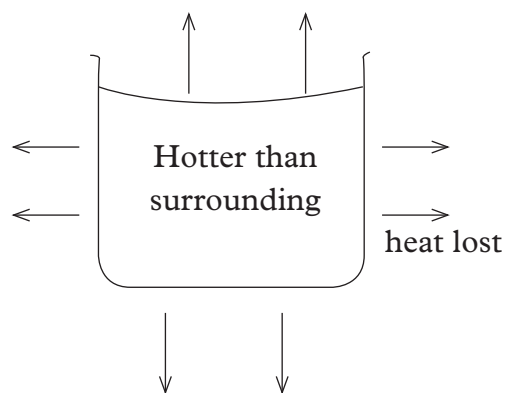
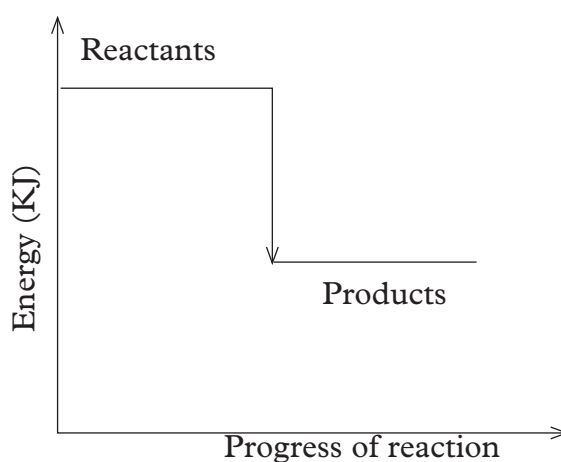

**Fig 2.2: Exothermic reaction**

From the fig 2.1 and 2.2 above it can be concluded that, in endothermic reactions the products are at a higher energy level compared to the reactants, while in an exothermic reactions products are at a lower energy level compared to the reactants. These expressions can be easily represented graphically.

### 2.3 Energy profile diagrams

An energy profile diagram is a graphical representation of the energy changes taking place in a particular reaction. It is also referred in some textbooks as **energy level diagrams**. The enthalpy change is normally represented on y-axis as delta H ( $\Delta H$ ) and reaction pathway on x-axis. Energy level diagrams simply show heat changes during reaction. We said earlier it is important that chemists be aware of the amount of energy changes (enthalpy change) involved in any reaction.



**Fig 2.3: Energy level diagram for exothermic reactions**

If the graphs are drawn to scale, then it is possible to calculate the heat change.

$\Delta H$  for a reaction = Energy of products – Energy of reactants

$$\text{Heat change, } \Delta H = H_{\text{products}} - H_{\text{reactants}}$$

In an exothermic reaction, the products formed are at a lower energy than the reactants see fig 2.3. The heat change in exothermic reaction is always negative.

In an endothermic reaction the products formed are at a higher energy level than the reactants, see fig 2.4.

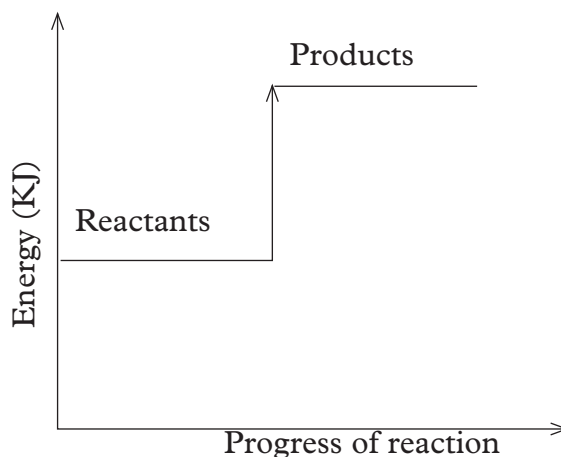

*Fig 2.4: Energy level diagram for endothermic reactions*

The heat energy for endothermic reaction is always positive.

### Discussion corner!

1. Why do you think a  $\Delta H$  –ve and a  $\Delta H$  +ve is assigned to exothermic and endothermic reactions respectively?
2. Draw enthalpy profile diagrams for:
  - a) The combustion of carbon to form carbon dioxide
  - b) The endothermic reaction below.  
$$\text{H}_2\text{O}(\text{g}) + \text{C}(\text{s}) \longrightarrow \text{H}_2(\text{g}) + \text{CO}(\text{g})$$
3. Apart from indicating the type of reaction in regard to heat changes, what other useful information can a chemist obtain from energy level diagrams?

## Check your progress 2.1

1. Draw energy level diagrams to represent the following process. Use  $\Delta H$  to show whether it is negative or positive in each case.
  - (a) Burning of a candle
  - (b) Photosynthesis
  - (c) Dissolving sodium hydroxide pellets
2. Identify whether the energy level diagram below is exothermic or endothermic. Give reason for your answer.

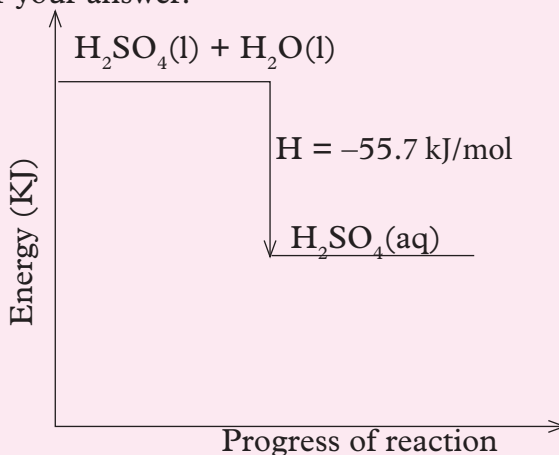

## 2.4 Bond breaking and bond formation

### Discussion corner!

1. Differentiate between ionic bonding and covalent bonding. Which bond do you consider to be stronger, give your reasons?
2. Compare the melting and boiling points of some ionic compounds and covalent compounds. You should notice with exception of diamond and silicon dioxide most covalent compounds have relatively lower melting and boiling points. What do you think bring about these huge differences in the melting and boiling points of compounds?
3. Explain why solid sodium chloride would easily dissolve in water yet it requires high temperatures to be melted?

Consider two magnets whose unlike poles are brought together. What happens to the two polarities? They tightly attract each other. In order to separate them, some amount of energy must be applied. Assuming the two magnets to be bonds, equally some energy is required to break bonds in the compounds.

## Energy changes in bond breaking and bond formation

For reactions to occur between reactants the bonds in reactants must be broken. As the products formed new bonds also form. Atoms or ions rearrange in the formation of new substances (new bonds).

Every chemical bond has a particular bond energy associated with it. This bond energy varies slightly depending on the compound that the bond occurs. Energy must be absorbed for bond breaking to take place, therefore ***bond breaking is an endothermic process.***

But in the formation of new bonds energy is usually given out. Therefore bond formation is an exothermic process. The difference between the energy absorbed and energy released is the overall enthalpy change of the reaction. Enthalpy change in chemical process can be determined through experiments.

The value of enthalpy change,  $\Delta H$  for a reaction depends on the physical conditions under which the measurement is done. Just as we indicate the state symbols of the substances involved in a reaction depending on the temperature of the surrounding, the value of  $\Delta H$  depends on the pressure under which the measurements are made. The changes for most reactions are carried out under conditions known as the ***standard conditions for the reaction.*** These conditions have been chosen as follows:

Standard temperature = 25°C (298K)

Standard pressure = 1 atmosphere.

Whenever enthalpy (heat) changes are measured under the above stated standard conditions, they are called standard enthalpies of the reactions. The special symbol,  $\theta$  is used as a superscript for  $\Delta H$ .

$\Delta H^\theta$  is the symbol for ***standard enthalpy.*** The superscript ( $^\theta$ ) indicates that the enthalpy change is measured under ***standard conditions.***

### Examples of standard enthalpies of reactions include:

$\Delta H_f^\theta$  denotes the standard enthalpy of formation.

$\Delta H_c^\theta$  denotes the standard enthalpy of combustion.

$\Delta H_n^\theta$  denotes the standard enthalpy of neutralisation.

To determine the final quantity of energy released or absorbed during a reaction, first find the amount of energy used to start the reaction and amount of energy released by the end of the reaction. Then compare the two amounts of energies obtained to see whether the energy used to start the reaction is more or less than the energy obtained.

## Bond energy

Every chemical bond has a particular energy associated with it. Bond energy is the amount of energy needed to break a specific covalent bond. It is denoted by the symbol  $E$ . The amount of energy released when a bond is formed is the same amount of energy needed to break the same type of bond. This obeys the law of conservation of energy.

The energy required to break covalent bonds between atoms have been determined experimentally. These energies are called bond dissociation energies. Table 2.1 shows some of bond dissociation energies.

**Table 2.1: Bond dissociation energies of various bonds**

Bond	Bond energies (kJ mol <sup>-1</sup> )
C—H	413
C—C	346
N—H	389
H—H	436
Cl—Cl	244
H—Cl	432
Br—Br	193
C—Cl	339
H—Br	365
C—Br	280

Known bond energies are used in calculating the overall energy (enthalpy) change of reactions. Let us now learn how to determine bond energy changes in chemical processes.

## 2.5 Calculating enthalpy changes using bond energies

Bond energies can be used to calculate the enthalpy change of some chemical reactions. First let us consider the following general reaction where diatomic molecules of  $X_2$  react with diatomic molecules of  $Y_2$ .

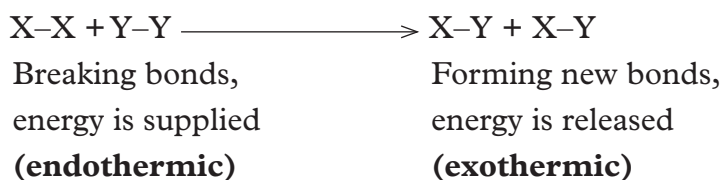

Assume the bond energies for the different type of bonds above are the ones provided in Table 2.2 below.

**Table 2.2: Specimen bond energies**

Bond	'Amounts' of energy required to break bond / released when bond is formed (kJ mol <sup>-1</sup> )
X-X	435
Y-Y	240
X-Y	430

To break bond between X-X, the energy required = 435 kJ mol<sup>-1</sup>

To break bond between Y-Y, the energy required = 240 kJ mol<sup>-1</sup>

Total energy required = 675 kJ mol<sup>-1</sup>

As we mentioned earlier, in an endothermic reaction  $\Delta H$  has a positive value. Since bond breaking is endothermic, the value should be written as +675 kJmol<sup>-1</sup>

Forming a bond between X - Y, energy released = 430 kJ mol<sup>-1</sup>

Forming another bond between X - Y, energy released = 430 kJ mol<sup>-1</sup>

Total energy released = 860 kJ mol<sup>-1</sup>

Since bond formation is an exothermic reaction, the value should be written as -860 kJ mol<sup>-1</sup>.

As we have seen, we got 185 kJ more than we 'invested' when two (X-Y) bonds in two XY molecules were formed. That is  $860 - 675 = 185$  kJ.

Note that if we use  $\Delta H$  notation, we must insert a negative sign in front of the answer i.e -185 kJ to show that energy was released. Here, the negative sign indicates that the reaction is exothermic and the equation can be written as

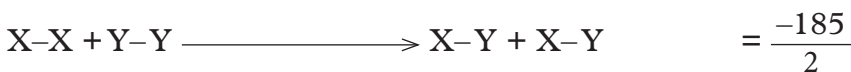

$$\Delta H = -92.5 \text{ kJmol}^{-1}$$

In the above example, do you consider the reaction to be exothermic or endothermic? Give reasons.

### Discussion corner!

1. Why do you think the energy is released during bond formation?
2. Suggest reasons why bond dissociation of hydrogen atoms as shown in table 2.1 are the strongest.

## Enthalpy of formation of hydrogen chloride

For example the reaction of chlorine and hydrogen gas to form hydrogen chloride gas.



Bond	Energy in kJ/mol
H-H	+436
Cl-Cl	+244
H-Cl	+432

To solve the problem, first determine which bonds are broken and the new bonds being formed.

### Step 1: Bonds being broken

- (i) H-H bond
- (ii) Cl-Cl bond

New bonds being formed

H-Cl

### Step 2: Find the energy absorbed during bond breaking

- (i) Energy absorbed in breaking the bond, H-H = +436 kJ mol<sup>-1</sup>
  - (ii) Energy absorbed to break the bond, Cl-Cl = +244 kJmol<sup>-1</sup>
- Total energy absorbed = 680 kJ mol<sup>-1</sup>

### Step 3: Find the energy released during new bond formation

Two H-Cl bond are formed, thus

$$\begin{aligned} 2(\text{H-Cl}) &= 2 \times (-432) \text{ kJ mol}^{-1} \\ &= -864 \text{ kJ mol}^{-1} \end{aligned}$$

### Step 4: Determine the resultant or net energy change

$$\begin{aligned} \text{Heat of reaction} &= \text{bond breaking} + \text{bond formation} \\ &= +680 + (-864) \text{ kJ mol}^{-1} \\ &= -184 \text{ kJmol}^{-1} \end{aligned}$$

Remember that -184 kJmol<sup>-1</sup> is released when 2 moles of hydrogen chloride are formed. Therefore the enthalpy of formation of HCl is,  $\frac{-184}{2} = -92 \text{ kJmol}^{-1}$

Notice from our working above the following important points.

- (i) How many bonds are broken and how many bonds are formed are determined.
- (ii) The positive and negative signs have been used consistently.
- (iii) Heat of reaction,  $\Delta H_r =$  energy difference (net or resultant energy)

We get the enthalpy change by adding up the bond energies.

When reaction equation is not provided, always write it down before proceeding

with the calculations. In some workings you may be required to draw energy level diagram for the reaction. Fig 2.5 below shows energy level diagram for enthalpy of formation of HCl.

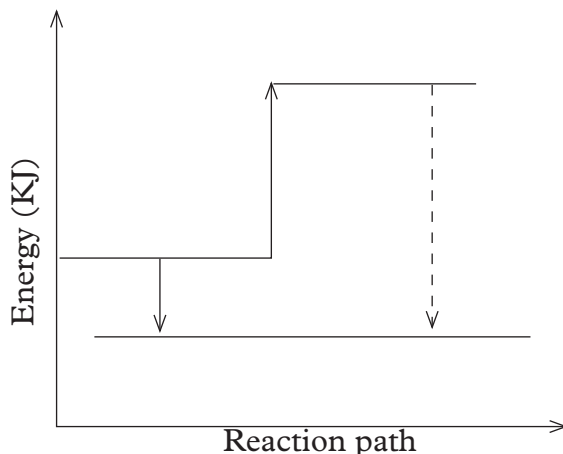

*Fig 2.5: Energy diagram for enthalpy of formation of HCl*

### Discussion corner!

1. Why was the use of positive and negative signs in the calculation above very essential?
2. Give reasons for dividing the resultant energy by factor of 2.

### Check your progress 2.2

1. Hydrogen burns in air to form steam.  

$$2\text{H}_2(\text{g}) + \text{O}_2(\text{g}) \longrightarrow 2\text{H}_2\text{O}(\text{g})$$
  - (a) Which bonds are broken?
  - (b) Use the bond energies in the following to calculate  $\Delta\text{H}$  for the reaction.

Bond	Bond energy ( $\text{kJmol}^{-1}$ )
H - H	436
O = O	489
O - H	464

2. Re-write the equation and include  $\Delta\text{H}$ .
3. Determine the enthalpy of formation of chloromethane from reaction of methane and chlorine gas. (Use bond energies provided in Table 2.1).  

$$\text{CH}_4(\text{g}) + \text{Cl}_2(\text{g}) \longrightarrow \text{CH}_3\text{Cl}(\text{g}) + \text{HCl}(\text{g})$$



## Determining enthalpies through experiments

It is possible to determine the amount of energy taken in from the surroundings or given out to surroundings through experiments.

### Discussion corner!

1. Define molar solutions.
2. Using your knowledge of molar solution, explain the meaning of:
  - (i) molar heat of solution
  - (ii) molar heat of neutralization
  - (iii) molar heat of combustion

## Enthalpy of neutralisation

### Activity 2.3

#### *To determine the enthalpy of neutralisation*

#### Apparatus and chemicals

100 ml measuring cylinder, thermometer, plastic beaker wrapped with cotton or newspaper, 1M hydrochloric acid, 1M sodium hydroxide, distilled water.

#### Procedure

1. Measure 50 cm<sup>3</sup> of 1M hydrochloric acid and transfer into the wrapped plastic beaker. Using a thermometer determine the steady temperature of the acid,  $T_1$ .

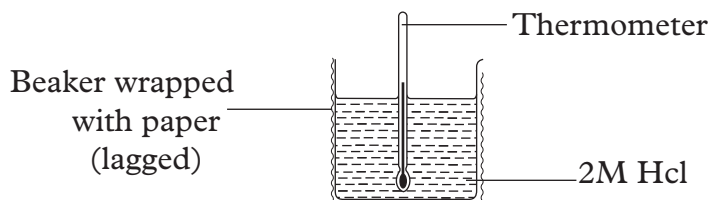

2. Rinse the measuring cylinder well using the distilled water.
3. Measure 50 cm<sup>3</sup> of 1M sodium hydroxide and determine its steady temperature,  $T_2$ .
4. Add all the sodium hydroxide into the beaker containing hydrochloric acid while stirring with the thermometer. Determine the highest steady temperature reached,  $T_3$ .

5. Record your results in a table similar to the one shown below.

	°C	K
Initial temperature $T_1 + T_2$ (°C)		
Final temperature, $T_3$ (°C)		
Change in temperature, $\Delta T$ (°C)		

### Activity questions

- Assuming that the specific heat capacity of the solution is  $4.2 \text{ J g}^{-1}\text{K}^{-1}$  and the density of the solution is  $1 \text{ g cm}^{-3}$ . Determine the heat of neutralization for the reaction. Given that  $\Delta H = Mc\Delta T$ . (Where  $\Delta H$  = heat of neutralization,  $M$  = mass of solution,  $c$  = specific heat capacity of the solution,  $\Delta T$  = change in temperature)
- Given that molar heat of neutralization is the heat change when an acid and a base react to produce one mole of water, calculate the molar enthalpy of neutralization of the reaction above.
- Suggest why the molar heat of neutralization obtained from the above data is lower than the theoretical value ( $\Delta H_n = -57.3$ ).
- Why was it important to rinse the measuring cylinder before use to measure another reagent.

### Class Activity

Repeat the experiment carried out in activity 2.3 but using the following reagents.

- 2M nitric acid and potassium hydroxide.
- 2M hydrochloric acid and ammonium hydroxide.

Determine the heat of neutralization of the above reactions. Write the chemical and ionic equations for the reactions.

### Worked example for enthalpy of neutralization

Table 2.3 Specimen results

	°C	K
Temperature of hydrochloric acid, $T_1$	22.5	295.5
Temperature of sodium hydroxide, $T_2$	22.0	295.0
Average temperature of the two solutions, $T_3$	22.25	295.25
Highest temperature reached, $T_s$	35.5	308.5
Temperature change, $\Delta T$ ( $T_s - T_3$ )	13.25	13.25

Assume the density of solution is,  $1 \text{ g cm}^{-3}$

Total volume of hydrochloric acid + alkali =  $100 \text{ cm}^3$

The mass of solution =  $1 \text{ g/cm}^{-3} \times 100 \text{ cm}^3 = 100 \text{ g}$

$$\begin{aligned}\text{Enthalpy of neutralisation is given by} &= \mathbf{mc \Delta T} \\ &= \frac{100 \text{ g} \times 4.18 \text{ Jg}^{-1} \times 13.25}{1000}\end{aligned}$$

$$\therefore \text{The enthalpy of neutralisation} = 5.538 \approx 5.54 \text{ kJ}$$

To get the molar enthalpy of neutralisation, we must first find out the number of moles that reacted.

$1000 \text{ cm}^3$  of HCl contained 2 moles

$$\therefore 50 \text{ cm}^3 \text{ of HCl contained } x \text{ moles}$$

Cross multiply and solve for x

$$\begin{aligned}x &= \frac{2 \text{ moles} \times 50 \text{ cm}^3}{1000 \text{ cm}^3} \\ &= 0.1 \text{ moles}\end{aligned}$$

0.1 moles of HCl give 5.54 kJ

$$\begin{aligned}\therefore 1 \text{ mole of HCl gives} &\frac{1 \times 5.54}{0.1} \\ &= -55.4 \text{ kJ/mol}^{-1}\end{aligned}$$

Similarly,  $50 \text{ cm}^3$  of 2M NaOH also contained 0.1 moles.

This means 0.1 moles evolved 5.54 kJ

$$\therefore 1 \text{ mole would evolve } y \text{ kJ}$$

*Cross multiply and solve for y*

$$\begin{aligned}y &= \frac{5.54 \text{ kJ}}{0.1 \text{ moles}} \\ &= -55.4 \text{ kJ/mol}^{-1}\end{aligned}$$

Therefore molar heat of neutralization ( $\Delta H_n$ ) is  $55.4 \text{ kJ mol}^{-1}$

Experiments have shown that for strong acids and strong alkali reactions, the value of the energy is about  $57 \text{ kJ mol}^{-1}$ . This is because all strong acids and alkalis completely dissociate in aqueous solution. The enthalpy change in their reactions is a constant value.

When both the acid and the alkali are weak, the enthalpy change is low; for example when ethanoic acid is neutralised by aqueous ammonia, the energy released is  $51.5 \text{ kJ mol}^{-1}$ .

## Enthalpy of solution

The *enthalpy of solution* is the heat evolved or absorbed when one mole of a substance is dissolved in so much water to produce an infinitely dilute solution. This means that further dilution produces no detectable heat change.

### *Class Activity*

Note: The teacher would organise you into suitable group sizes.

### *To determine the enthalpy of solution of ammonium nitrate*

#### What you are required to do

- (i) Select the appropriate apparatus and materials.
- (ii) Outline the procedure for carrying out this experiment.
- (iii) Proceed to do the experiment and record your results properly.
- (iv) Using the results obtained from the experiment, calculate the:
  - a) Heat of solution for reaction. Given that  $\Delta H = Mc\Delta T$ , where:  
 $\Delta H$  = heat of solution  
 $M$  = mass of solute in grams  
 $c$  = specific heat capacity of the solution  
 $\Delta T$  = change in temperature
  - b) Enthalpy change for the molar solution of ammonium nitrate. (RAM of N = 14, H = 1, O = 16)
  - c) Represent the dissolution of ammonium nitrate in water in an energy level diagram.

## Enthalpy of displacement

### Review corner

Using your previously acquired knowledge;

1. Explain what a displacement reaction is. Give an example of such reaction.
2. Draw reactivity series of metals.
3. Predict if a displacement reaction is exothermic or endothermic process.

### Class Activity

In suitable group size or as a class, design and conduct an experiment to determine the enthalpy of displacement of copper from its salt solution by suitable metal.

The following suggested outline can guide you.

- (i) Title of the experiment
- (ii) List of apparatus and reagents required
- (iii) Procedure
- (iv) Recording of data

Table 2.4: Sample table for recording data

	°C	K
Initial temperature of copper (II) sulphate, $T_1$ (°C)		
Final temperature of copper (II) sulphate, $T_2$ (°C)		
Change in temperature, $\Delta T_3$ ( $T_1 - T_2$ )		
Initial colour of solution before reaction		
Colour of solution after reaction		

### Activity questions

1. Write the full chemical and ionic equation for the reaction above.
2. Using the number of moles, determine which substance between zinc and copper ions was in excess.
3. Determine the heat of displacement and molar heat of displacement in the above experiment.
4. Why is the reaction called displacement reaction? Was the reaction exothermic or endothermic?
5. Give a reason for the colour in this experiment.

## Enthalpy change of combustion

Enthalpy of combustion can be worked out by burning a known mass of substance and using the heat energy released to raise the temperature of a specific mass of water.

### Enthalpy change of combustion of ethanol

#### Activity 2.4

*To determine the enthalpy change of combustion of ethanol*

#### Procedure

1. Weigh the spirit lamp containing ethanol. This is mass,  $M_1$ .
2. Pour 200 cm<sup>3</sup> of water into the calorimeter.
3. Stir the water and record its temperature,  $T_1$ .
4. Place the spirit burner underneath the calorimeter and light it
5. Keep stirring the water with the thermometer until there is temperature rise of about 15°C. Record the new temperature,  $T_2$ .
6. Remove the spirit burner and re-weigh it. This is mass,  $M_2$ .
7. Record your results in a table similar to the one below.

**Table 2.5: Sample table for recording results**

Unit for measurement	Reading
Volume of water in container	_____ cm <sup>3</sup>
Initial temperature of water	_____ °C
Final temperature of water	_____ °C
Initial mass of lamp + its content, $M_1$	_____ g
Final mass of lamp + its content, $M_2$	_____ g
Mass of fuel used	_____ g

### Activity questions

- Given that specific heat capacity of water is  $4.2 \text{ Jg}^{-1}\text{K}^{-1}$ , density of water is  $1 \text{ g/cm}^3$ ;
  - Calculate the quantity of heat absorbed by water.
  - Assuming that the quantity of heat given out by burnt ethanol = heat taken by water, calculate the molar enthalpy change of combustion of ethanol (RFM of ethanol = 46).
- Suggest a reason why it is not necessary to burn all the fuel in the lamp.
- The amount of heat produced when a fuel is burnt is theoretically higher than the value obtained practically. Mention four possible errors in the experiment, which could be responsible for this. The theoretical enthalpy change of combustion of ethanol is  $-1368 \text{ kJ}$ .

### Worked example for enthalpy of combustion of ethanol

Now, let us use the following sample results to show how we calculate the molar heat of combustion of ethanol.

$$\text{Volume of water used, } V = 400 \text{ cm}^3$$

$$\text{Initial temperature of water, } T_1 = 28.0^\circ\text{C}$$

$$\text{Final temperature of water, } T_2 = 40.0^\circ\text{C}$$

$$\text{Change in temperature, } \Delta T = (40 - 28) = 12.0^\circ\text{C}$$

$$\text{Initial mass of lamp and its contents } (M_1) = 28.30 \text{ g}$$

$$\text{Final mass of lamp and its contents } (M_2) = 27.38 \text{ g}$$

$$\text{Mass of ethanol burnt} = (M_1 - M_2) = (28.30 - 27.38) = 0.92 \text{ g}$$

$$\text{Specific heat capacity of water} = 4.18 \text{ Jg}^{-1}\text{K}^{-1}$$

Calculate the molar heat of combustion of ethanol.

$$(C = 12.0; H = 1.0; O = 16.0)$$

Notice that it is not necessary to burn all the ethanol. The little we burn transfers all

the heat into the water. We assume none of the heat evolved is lost, for example, by being carried away by wind, or some being absorbed by the beaker or thermometer.

Heat evolved = mass of water x specific heat capacity x temperature change

$$\text{i.e. } \Delta H = mc\Delta T$$

$$\text{Substituting the values, we get } = \frac{400 \times 4.18 \times 12}{1000}$$

$$\Delta H = 20.064 \text{ kJ}$$

We burnt only 0.92 g of ethanol.

$$1 \text{ mole of ethanol, } \text{CH}_3\text{CH}_2\text{OH} = 46 \text{ g}$$

$$x \text{ mole of ethanol} = 0.92 \text{ g}$$

$$= \frac{0.92 \times 1 \text{ mole}}{46}$$

$$= 0.02 \text{ moles}$$

This means 0.02 moles evolved 20.064 kJ

∴ 1 mol could evolve y kJ

$$y = \frac{20.064 \text{ kJ}}{0.02 \text{ mol}}$$

$$= 1003.2 \text{ kJ mol}^{-1}$$

The molar heat of combustion of ethanol = -1003.2 kJ

Or

0.92 g of ethanol evolved 20.064 kJ

46 g of ethanol would evolve y kJ

$$\therefore y = \frac{20.064 \text{ kJ} \times 46 \text{ g}}{0.92 \text{ g}}$$

$$= -1003.2 \text{ kJ mol}^{-1}$$

Combustion of ethanol is exothermic, the heat of reaction,  $\Delta H = -1003.2 \text{ kJ mol}^{-1}$ .

The equation for the combustion reaction is

Ethanol + oxygen  $\longrightarrow$  carbon(IV) oxide + water + heat

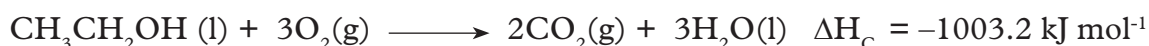

**Note** that if we burn only a little of fuel, we do not call the amount of heat evolved molar heat of combustion. We must find the mass of one mole, and then calculate the molar heat of combustion. We can now define the molar enthalpy of combustion.

The molar enthalpy of combustion of a substance,  $\Delta H_{\text{c}}$ , is the enthalpy change when one mole of a substance is completely burnt in excess of oxygen.

## Hess's law

Enthalpy change of some reactions is difficult to determine practically. The conditions required cannot easily be achieved in a laboratory. For example, in determining standard enthalpy of formation of carbon (II) oxide from burning carbon in limited air supply is very difficult. This is because some carbon is always being formed.

Such enthalpy changes are determined theoretically by relating the heat of combustion of the compound to the heats of combustion of the constituent elements that form the compound. This relationship follows Hess's law which states that **the enthalpy change in converting reactants to products is the same regardless of the route taken as long as the initial and final conditions are kept constant.**

Hess's law can be represented in an enthalpy cycle as shown in the figure 2.6 below.

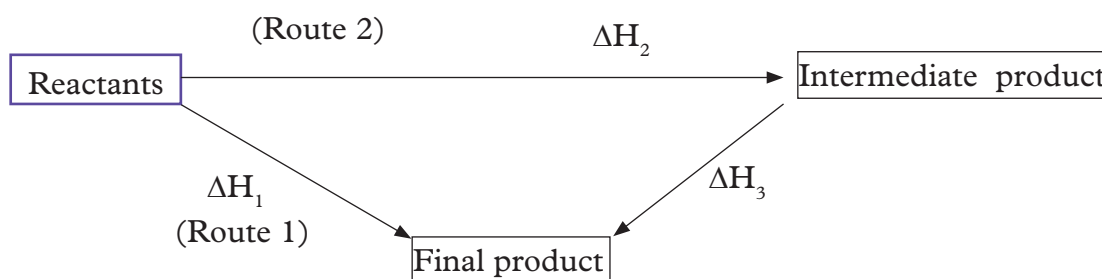

**Fig 2.6: Thermochemical (energy) cycle**

From Fig 2.6 you can see that to form products you can follow the direct route  $\Delta H_1$  or the indirect route  $\Delta H_2 + \Delta H_3$ .

When you use Hess's law then it follows that:

$$\Delta H_1 = \Delta H_2 + \Delta H_3$$

For example the information below can be used to determine the enthalpy of reaction:

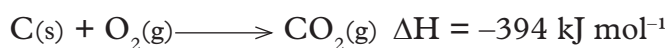
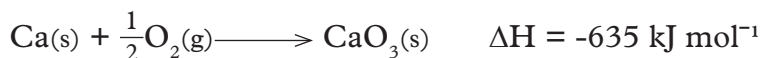

### Solution:

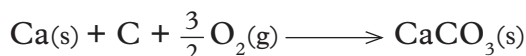



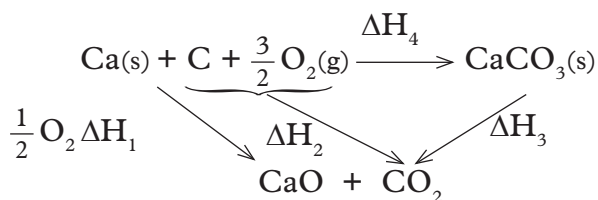

$$\Delta H_1 + \Delta H_2 = \Delta H_3 + \Delta H_4$$

$$\Delta H_4 = \Delta H_1 + \Delta H_2 - \Delta H_3 = -635 + -394 - (-1207)$$

$$= +178 \text{ kJ/mol}$$

## 2.6 Activation energy and their energy level diagrams

For a reaction to take place, energy must be supplied to start off the reaction. This energy is called activation energy ( $E_a$ ).

Activation energy ( $E_a$ ) is the minimum amount of energy required for a reaction to take place.

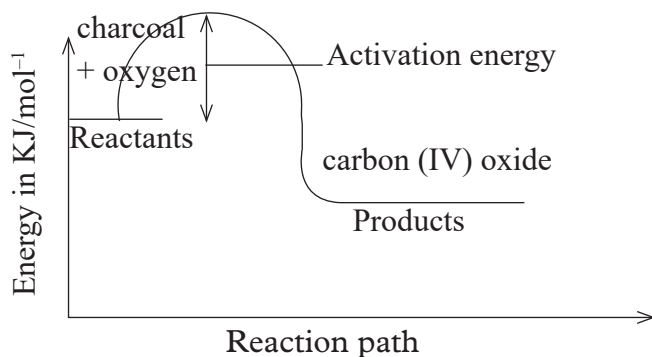

*Fig 2.7: Energy level diagram showing activation energy for exothermic reaction*

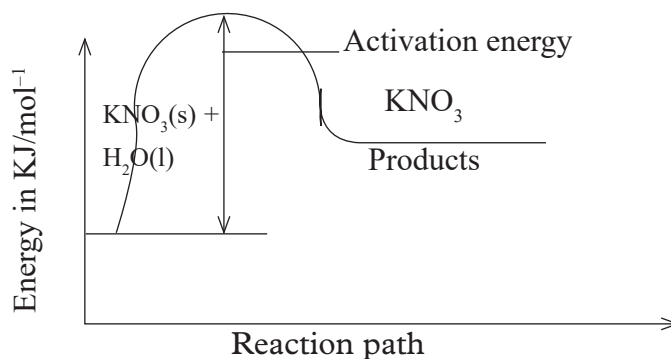

*Fig 2.8: Energy level diagram showing activation energy for endothermic reaction*

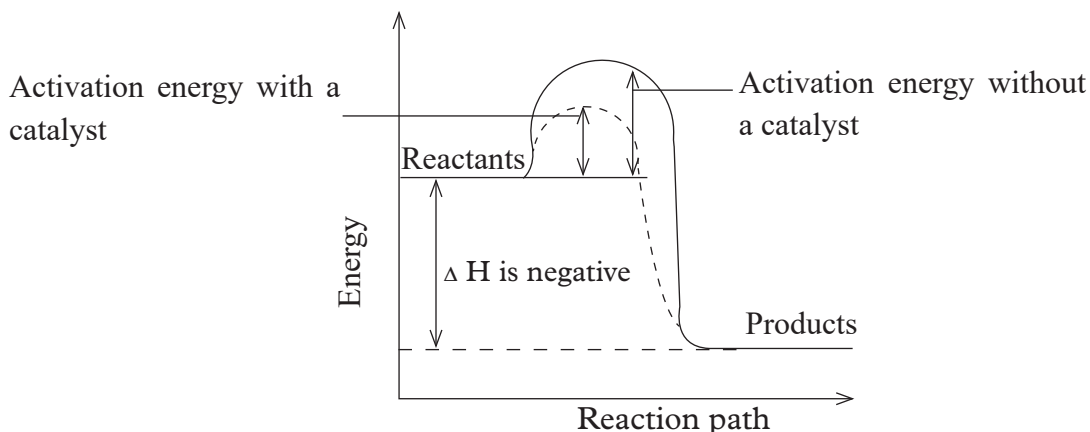

**Fig 2.9: Activation energy for catalysed and uncatalysed reaction.**

### Check your progress 2.3

- The following data was obtained during an experiment to determine the molar heat of combustion of ethanol.

Volume of water used = 500 cm<sup>3</sup>

Initial temperature of water = 25°C

Final temperature of water = 44.5°C

Mass of ethanol + lamp before burning = 121.5g

Mass of ethanol + lamp after burning = 120.0g

Calculate:

- Heat evolved during the experiment (density of water = 1 g/cm<sup>3</sup>, specific heat capacity of water = 4.2 Jg<sup>-1</sup>K<sup>-1</sup>).
- Molar heat of combustion of ethanol (C = 12, O = 16, H = 1).
- Write the thermo equation for the complete combustion of ethanol.
- At 298 K and one atmosphere pressure, graphite changes into diamond according to the equation.



Sketch a simple energy profile diagram for the above change.

- Methane burns in oxygen as shown by the equation below.



- Calculate the heat change for the reaction using the bond energies given in the table below.

Bond	Bond energy kJ / mol
C – H	413
O = O	497
C = O	740
O – H	463

### Learning outcomes

Knowledge and understanding	Skills	Attitudes
<ul style="list-style-type: none"> <li>Understand chemical kinetics (rates of reactions), equilibria, redox reaction and electrochemistry.</li> </ul>	<ul style="list-style-type: none"> <li>Investigate the effect of concentration, pressure, particle size and temperature on the speed of reactions.</li> <li>Suggest a suitable method for investigating the effect of a given variable on the speed of a reaction.</li> <li>Predict how changes in properties (e.g. volume, concentration, temperature) will change reactions at equilibrium.</li> <li>Carry out investigations to establish how chemical reactions produce electricity, and how electricity is used to force reactions to occur.</li> </ul>	<ul style="list-style-type: none"> <li>Appreciate the importance of kinetics in understanding electro-chemistry.</li> </ul>

### Introduction

Did you know that burning methane to produce heat for cooking is an oxidation reaction just like rusting of iron? What do you think is the difference between these two reactions? Can you remember how fast the decomposition of hydrogen peroxide was before and after addition of manganese (IV) oxide in your Biology practicals? Reactions vary in their speed in general and this has critical implications on most industrial processes. In this unit we will be able to answer some of the above questions.

#### *Group Task*

A cement factory wants to increase its production from 1000 bags per hour to 5000 bags in order to meet the prevailing market demand. In your groups, research and write a report on the factors that the factory must consider to realise the desired higher level of production.

The production timelines for the various reaction stages or processes must be included in the report.

From the group activity above, you should be able to realise that the rate of reaction of an activity at every production stage is crucial. It must be carefully analysed and better mechanisms or ways considered which will increase the rate of activity at any given stage for the achievement of the needed outcome.

### The Facts

The speed of chemical reactions differ greatly depending on the reactants and a number of environmental factors. Some reactions occur very fast while others are very slow.

The rate of a chemical reaction is defined as the rate of change of concentration (or amount of reactants) in a unit time. It is also the rate of formation of products in unit time. i.e.

$$\text{Rate of reaction} = \frac{\text{Change in concentration/amount of reactants}}{\text{Time taken for the change to occur}}$$

$$\text{Rate of reaction} = \frac{\text{Change in concentration/amount of products formed}}{\text{Time taken for the products to form}}$$

From the above, the rate of a chemical reaction is the rate of decreasing reactants to form an increasing product.

The SI unit of time is second(s). Minutes and hours are also used.

### Individual Task

1. Name some of the laboratory reactions you did that:
  - (a) the reactions were very fast.
  - (b) the reactions were very slow.
2. What informed your conclusions that these reactions were either fast or slow?

## 3.1 The Collision Theory and Activation Energy ( $E_a$ ) Theory

### Discussion corner!

1. Why do you think some reactions occur at room temperature while others require heating before they occur?
2. What is activation energy?
3.
  - (a) Explain briefly the kinetic theory of matter.
  - (b) Using the above theory explain why solid sodium chloride and solid lead (II) nitrate when mixed will not react but when in solution they react.

## The Facts

All substances are made up of particles (Kinetic Theory). Chemical reactions are possible due to collisions of these particles. For a chemical reaction to take place, the particles must collide. This is what is referred to as the collision theory.

The following points are true about collision theory.

- Reactions take place due to collisions of reacting particles. These particles include atoms, ions or molecules.
- Not all collisions between particles may be fruitful. By “fruitful”, we mean that a collision produces products. The collisions which produce a chemical reaction are called **fruitful collisions**. The rate at which particles collide is called collision frequency. The greater the fruitful **collision frequency**, the faster the reaction.
- Colliding particles need minimum amount of energy before they can bring about a chemical reaction. The minimum energy required for this is called **activation energy**.

The rate of reaction is actually the number of atoms, ions or molecules that react per unit time to form products. Increasing the rate of reaction means increasing the number of fruitful collisions between particles.

Reactions involving solids take place at the surface of the solid because it is only here that collisions with particles of other reactants can take place.

In a solid lump, most particles are locked up inside. In order to react, these particles must have fruitful collisions with the reacting reagent.

If the reacting reagent is a liquid or a gas, their particles collide with the particles of the solid as shown in Fig. 3.1 below.

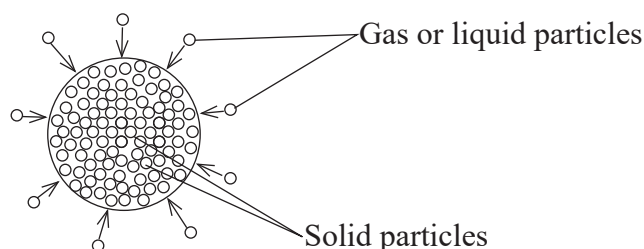

**Fig 3.1: Collision between particles i.e solid and gases/ liquid**

In gases or liquids, the particles are constantly in random motion. During the reaction, the particles collide. And if they collide hard enough, a reaction takes place effectively.

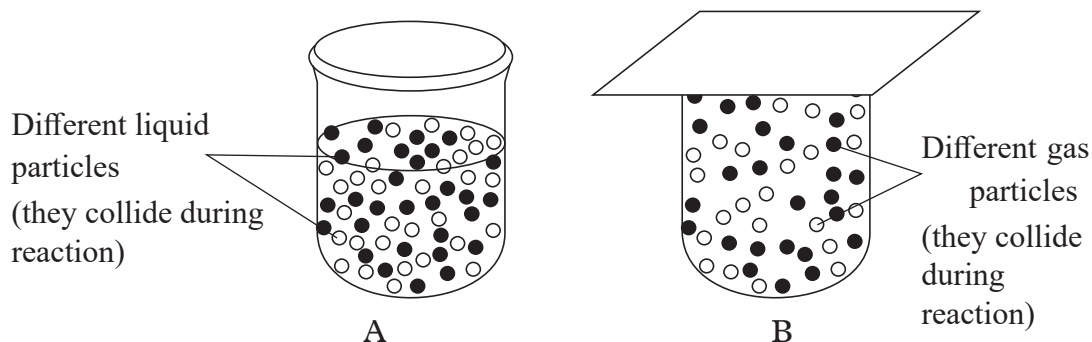

**Fig 3.2: Collision between particles of a liquid and gas**

For a chemical reaction to occur there is the minimum amount of energy that the reactants need. This minimum energy is known as **activation energy**. It is helpful in bringing about fruitful collisions of the reacting particles. Activation energy ( $E_a$ ) is usually required in bond breaking of the reacting particles. Activation energy does not influence whether a reaction is exothermic or endothermic.

The need of reacting particles for activation energy before reaction starts explains why endothermic reactions cannot proceed without further heating because it does not generate its own energy to constantly apply the activation energy. It therefore requires continuous supply of more energy to sustain it to completion.

Exothermic reaction proceeds without further heating because it generates its own energy to overcome activation energy barrier.

### Check your progress 3.1

1. Describe the rate of reaction in regard to product production.
2. Suggest some reactions in the school laboratory which are
  - (i) very fast and
  - (ii) slow
3.
  - (i) Differentiate between collision theory and activation energy.
  - (ii) Explain why particles sometimes collide but products are not formed.

## 3.2 Determining of the rate of chemical reaction

The rate of a chemical reaction can be measured using various methods. These include:

- (i) Volume in the case of gas.
- (ii) Mass of the precipitate being formed.
- (iii) Change in mass of the reactants or products in unit time or diminishing of one of the reactants.

Whatever the method chosen to measure the rate of reaction, it should ensure that:

- (i) The change is taking place in a reasonable amount of time. The interval chosen should not be too long or very fast depending on the rate of change.
- (ii) It should give an observable change during the desirable reaction time.

### Discussion corner!

**In groups of two,**

1. Describe how you can measure:
  - (i) the rate of a chemical reaction of decomposition of hydrogen peroxide before and after addition of manganese (IV) oxide.
  - (ii) the pulse rate and heart rate of a person.
2. How do you think the rate of reaction, of nutrients absorption in different fertilisers is applied in manufacturing?
3. In medicine, how long is the medicine going to stay in the body system before finally being removed is an important consideration in the dosage administration. Why is this the case?

## 3.3 Factors affecting rates of reaction

### *Individual Task*

Using your previously acquired knowledge:

- (i) list the laboratory reactions where you were required to control amount of reactant, amount of heat, use of powdered or small sized particles.
- (ii) Why do you think you were advised so?

The following factors can affect the rate of a chemical reactions.

- (a) Concentration
- (b) Temperature
- (c) Surface area
- (d) Pressure
- (e) Catalyst
- (f) Light (type and intensity)

## Effect of concentration on rate of reaction

### Activity 3.1

*To demonstrate the effect of concentration on reaction rate using sodium thiosulphate and dilute hydrochloric acid*

#### **Apparatus and reagents**

50 ml measuring cylinder, 250 ml glass beakers or conical flask, filter paper, stop watch 0.5M sodium thiosulphate solution, 1M hydrochloric acid, felt pen.

#### **Procedure**

1. Measure 20 cm<sup>3</sup> of 0.5M sodium thiosulphate into a 50 cm<sup>3</sup> glass beaker.
2. Place the beaker on a white piece of filter paper marked with ink mark 'X' on it.
3. Measure 20 cm<sup>3</sup> of 1M hydrochloric acid using a 50 cm<sup>3</sup> measuring cylinder.
4. Pour the acid into the beaker containing sodium thiosulphate and simultaneously starting the stop watch/clock.
5. Determine the time taken for the ink mark 'X' to become obscure (or disappear) when viewed from above.
6. Repeat the above steps 1-5 for the different volumes of the acid and different volumes of added distilled water as shown in the table 3.1 below. Then complete the table accordingly.

**Table 3.1: Findings on effect of concentration on rate of reaction**

Volume of acid (cm <sup>3</sup> )	Volume of water (cm <sup>3</sup> )	Concentration of the acid (mole/litre)	Volume of sodium thiosulphate (cm <sup>3</sup> )	Time taken for mark 'X' to be obscure (seconds)	Reciprocal of time $\frac{1}{t}$
20.0	0.0	0.5	20.0		
18.0	2.0	0.45	20.0		
16.0	4.0	0.40	20.0		
14.0	6.0	0.35	20.0		
12.0	8.0	0.30	20.0		
10.0	10.0	0.25	20.0		

#### **Activity questions**

1. On separate graph papers, plot a graph of:
  - (i) Volume of acid used (y-axis) against time. Label this graph I.
  - (ii) Volume of acid used (y-axis) against 1/t. Label this graph II.



2. Explain the shape of graph I.
3. From graph II, determine the time taken for the cross to be obscured when the volume of the acid is:
  - (i) 13 cm<sup>3</sup>
  - (ii) 15 cm<sup>3</sup>
  - (iii) 15 cm<sup>3</sup>
4. From graph II, determine the volume of the acid used if the time taken for the cross to be obscured is:
  - (i) 25 seconds
  - (ii) 30 seconds
  - (iii) 40 seconds

### ***Class Activity***

In activity 3.1, the effect of concentration on rate of reaction was measured using the concentration of hydrochloric acid. Now you are required to carry out the same investigation but then vary the concentration of sodium thiosulphate. Design, plan and proceed to conduct the experiment. Record your results appropriately in a suitable table.

#### ***Activity questions***

1. What is the name of the yellow precipitate formed?
2. Write the chemical equation for the reaction.
3. Suggest some of things that must be observed to get consistent results.

### ***The Facts***



From the activities above, it is clear that the higher the concentration, the faster the rate of a chemical reaction. This is in agreement with its collision theory. An increase in concentration of the reactants reduces the distance between the reacting particles increasing the frequency of their fruitful collisions. The greater the number of collisions, the more vigorous and faster the rate of reaction. Practically an increase in concentration reduces the time taken for the reaction to take place.

The plotting of graph of volume against time as well or that of increasing mass of sodium thiosulphate gives a curve shape. That of reciprocal of volume or mass against  $\frac{1}{t}$  (rate) forms a straight line through the origin. See Fig 3.3

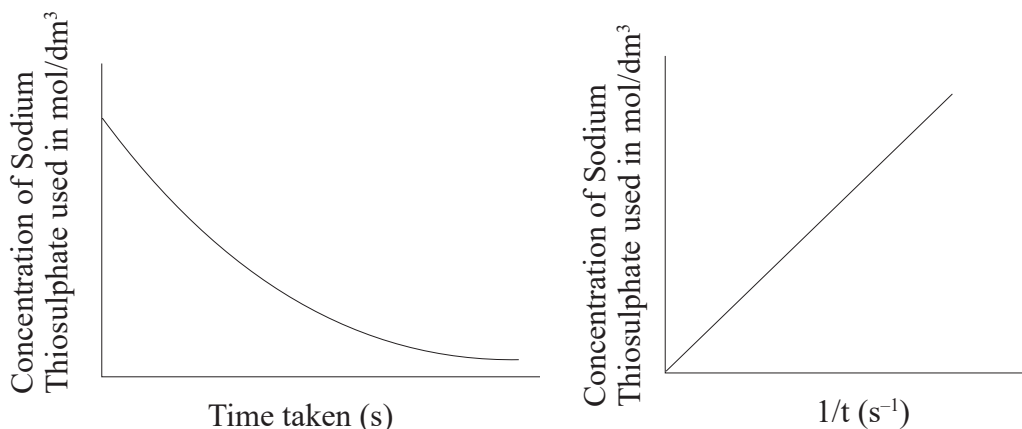

**Fig 3.3: Graphs of concentration against time taken**

The more sodium thiosulphate dissolved in a given amount of water (the higher its mass) and the more the volume of acid in comparison to added water) the higher the concentration of the reacting particles present in the reacting mixture. From the graph, we can conclude that the higher the concentration of reactants, the faster the rate of reaction.

When sodium thiosulphate ( $\text{Na}_2\text{S}_2\text{O}_3$ ) and dilute hydrochloric acid react, a yellow precipitate of sulphur is formed.

## Effect of temperature on the rate of reaction

### Review corner

Do you recall in the laboratory preparation of chlorine, two methods that can be used.

One method required the use of heat and there was no use of heat in another method.

- (i) Identify the two methods of chlorine preparation in the laboratory.
- (ii) Using the knowledge acquired so far in this unit, why was the use of heat necessary in one of the methods named above?

### Activity 3.2

**To investigate the effect of temperature on rate of reaction**

#### Apparatus and reagents

50 ml measuring cylinder, 250 ml glass beaker, filter paper, stop watch, thermometer, 1M HCl, 1M sodium thiosulphate, distilled water.

### Procedure

1. Measure 25 cm<sup>3</sup> of 1M sodium thiosulphate and place it into a 100 cm<sup>3</sup> glass beaker.
2. Place the beaker on a piece of filter paper with a large ink mark 'X' on it.
3. Determine and record its temperature as room temperature in a table like the one shown below.
4. Measure 25 cm<sup>3</sup> of 1M hydrochloric acid solution. Make sure you rinse well the measuring cylinder if you are using the same one.
5. Pour the acid into the beaker containing sodium thiosulphate and immediately start the stop watch as you swirl the content.
6. Determine and record the time taken for the mark 'X' to disappear.
7. Measure another 25 cm<sup>3</sup> sodium thiosulphate solution and place into a beaker. Heat the solution to 40°C. Then add another 25 cm<sup>3</sup> of the acid to the beaker, starting the stopwatch immediately and swirling the contents. Record the time taken for the mark X to disappear.
8. Repeat the above procedure for different temperatures.
9. Complete the table below.

Table 3.2: Results of effect of temperature on reaction rate

Temperature of Na <sub>2</sub> S <sub>2</sub> O <sub>3</sub>	Room temperature	40	50	60	70
Time taken for mark X to be obscured/not visible (seconds)					
Reciprocal of time( $\frac{1}{t}$ )					

### Activity questions

1. Plot a graph of temperature(y-axis) against  $\frac{1}{t}$ .
2. Explain the shape of the graph you have drawn. What can you conclude from the graph?

### Group Task 2

In groups of four; design, plan and carry out an experiment to observe the effect of temperature on reaction rate using volume as method of measuring the rate of reaction.

*Hint:* Use magnesium ribbon as one of the reagents.

## The Facts

An increase in temperature increases the kinetic energy (velocity) of the reacting particles, thereby increasing their collision frequency. The higher the collision frequency results to increased rate of reaction. Increased kinetic energy of the particles provides them with the necessary activation energy required for the reaction to occur. The reaction therefore proceeds at a faster rate.

When you plot the graph for activity 3.2 and the subsequent one, you should obtain a similar one as shown in Fig 3.4 below.

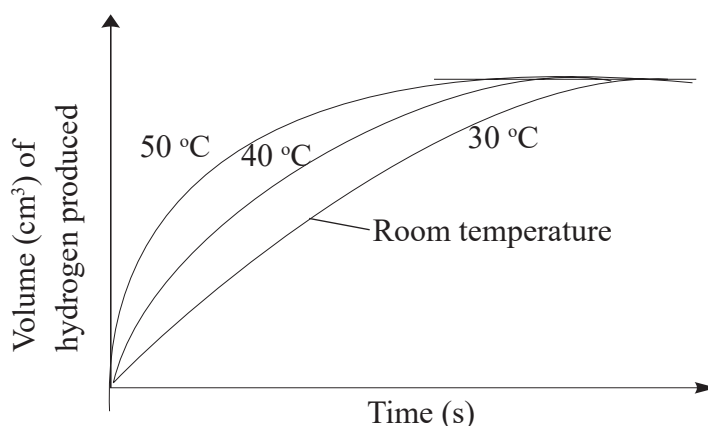

*Fig 3.4: A graph of volume of hydrogen produced against time*

## Effect of surface area on rate of reaction

Why do you think you have to chew solid foods into smaller particles before swallowing?

In general this has to do with the surface area of the food where chewing helps to break down the food into smaller particles. This makes it easy for swallowing as well increases the surface area of the food for enzymatic action during digestion.

### Review corner

1. In laboratory preparation of ammonia gas using calcium hydroxide and ammonium chloride, you were required to grind them into powder. What was the reason for doing this?
2. Name another laboratory reaction where you were required to use smaller particles for faster reaction to take place.

### Activity 3.3

*To investigate the effect of surface area on the rate of reaction using calcium carbonate and hydrochloric acid*

#### **Apparatus and reagents**

50 ml measuring cylinder, conical flasks, watch glass, weigh balance, stop watch, collecting syringe, cotton wool. 2M hydrochloric acid, powdered calcium carbonate and marble chips.

#### **Procedure**

1. Measure 20 cm<sup>3</sup> of 2.0 M hydrochloric acid into each of two separate conical flasks labelled 1 and 2.
2. Using a watch glass weigh 5 g of powdered calcium carbonate and another 5 g of marble chips.
3. Place the conical flask 1 on an electronic balance. Reset the balance scale to 0.0.

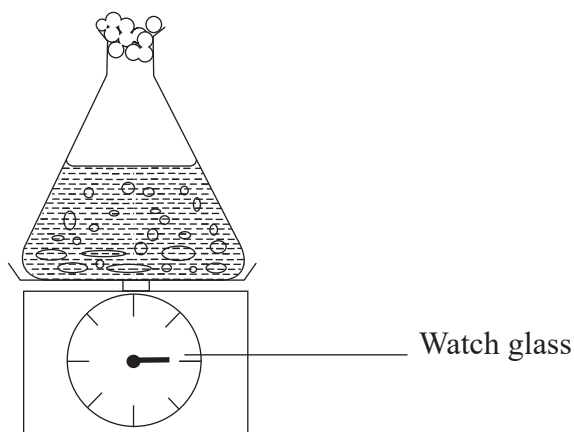

**Fig 3.5: Determining loss of mass of calcium carbonate**

4. Put the weighed sample, 5 g, of the powdered calcium carbonate into the conical flask 1. Plug cotton wool as shown in the diagram. Determine the scale reading and record it at time 0.0, simultaneously starting the stop watch.
5. Determine and record the scale reading after every a half a minute and complete Table 3.3.
6. Repeat the above steps 3 - 5 for flask 2 but using marble chips instead. Complete table 3.4.

**Table 3.3: Experiment results of powdered calcium carbonate**

Time(minutes)	0.0	0.5	1.0	1.5	2.0	2.5	3.0	3.5	4.0
Mass of powdered calcium carbonate									
Mass lost									

**Table 3.4: Experiment results of marble chips**

Time(minutes)	0.0	0.5	1.0	1.5	2.0	2.5	3.0	3.5	4.0
Mass of marble chips									
Mass lost									

### Activity questions

1. On the same axis plot a graph of mass lost for results obtained in Table 3.3 and Table 3.4 against time.
2. In which experiment was the rate of reaction faster. Explain why.
3. Which other parameter could be measured to determine the rate of reaction in the above experiment. What apparatus would you need for its measurements?
4. Write the chemical equations for the reactions that take place in activity 3.4.
5. What do you conclude from the graphs?
6. Suggest the reason for use of cotton wool in this experiment.

### The Facts

**Surface area** is the area of contact. An increase in surface area increases the rate of reaction. That is why reaction was fastest for the powdered calcium carbonate. When the surface area is increased it increases the area of contact between the reactants thus increasing the number of successful collisions between the reactants. The powdered calcium carbonate has larger surface area than the marble chips hence its faster rate of reaction.

If the volume of carbon dioxide produced is to be measured, the time taken to produce it is assumed to correspond to loss in mass. When you plot your graph using the results obtained in activity 3.3, you should obtain a graph like the one shown in Fig 3.6 below.

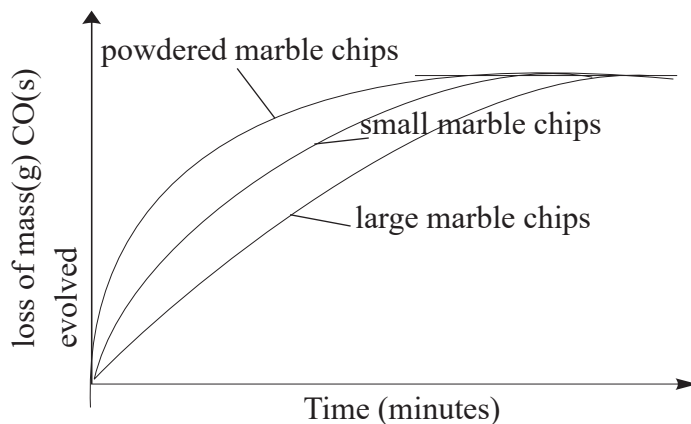

*Fig 3.6: Curves of loss of mass of calcium carbonate and marble chips against time*

## Effect of pressure on rate of reaction

### Review corner

Using your previously acquired knowledge,

1. Name the gas laws learnt in Secondary 3.
2. Identify which gas law(s) can relate to the rate of reaction. Why did you select it or them?
3. Using the collision theory describe how pressure can affect the rate of reaction

### Activity 3.4

With the help of your teacher rearrange the class so as to create space at the center of your class (you can make it a square of given dimensions). Select five students and make them to run randomly within the space created, count how many times they collide with each other. Reduce the space and have the same five run randomly within the reduced space. Count and record how many times they collide.

### Discussion corner!

1. Was there any difference in the number of collisions in the first and second time? Explain your answer.
2. How do you think this activity can be used to explain the effect of pressure to the rate of chemical reaction?
3. Define pressure, and state the type of reactions likely to be affected by changes in pressure.

## The Facts

Pressure affects only gaseous reactants. An increase in pressure is as a result of reduction in the volume (Boyles law) in the space in which the particles are contained. Increasing pressure for gaseous reactants means more reacting particles are now available in the same space bringing the reacting particles much closer to each other. This increases their chances of effective (fruitful) collision to form products. An increase in pressure therefore increases the rate of reaction.

At industrial level, this is an important factor in some reactions such as:

- (a) Contact process for the manufacture of sulphuric acid.



- (b) Haber process for manufacture of ammonia



- (c) Ostwald's process for the manufacture of nitric acid



The effect of pressure on reaction rate is not felt in solids and liquids. This is because the solid and liquid particles have fixed positions in their strong bonds and therefore no much degree of freedom (Kinetic Theory of matter).

## Effect of catalyst on rate of reaction

Think of a football match with spectators cheering up their home players. The spectators may influence the match results by how well they motivate their players by cheering. The team that is well motivated might eventually win the match. Although the spectators do not participate in the game but they can influence the way the game is played.

### Review corner

In unit 2, we learnt about activation energy for catalysed and uncatalysed reactions. Using that knowledge;

1. Draw an energy level diagram of activation energy for catalysed and uncatalysed reaction.
2. How can you justify the reasons for lower activation for catalysed reaction?
3. Name some of the laboratory reactions you performed that a catalyst was used. Name the catalyst in the named reactions.
4. In Biology practical, a fresh liver when placed in hydrogen peroxide speeds up the reaction. Name the enzymes responsible for this.
5. Define a catalyst and enzyme.



### Activity 3.5

#### *Determining the effect of manganese (IV) oxide on rate of decomposition of hydrogen peroxide*

##### **Apparatus**

50 ml measuring cylinder, conical flask, cork, wooden splint, dropping funnel, delivery tube, calibrated gas jar, stop watch, filter paper, filter funnel, electronic balance, beehive shelf, source of heat.

##### **Reagents**

Manganese dioxide, hydrogen peroxide.

##### **Procedure**

1. Arrange the apparatus as shown in Fig 3.7 below.
2. Decompose the hydrogen peroxide without manganese (IV) oxide by dropping the hydrogen peroxide into the round bottomed flask. Record the volume of the gas produced at various intervals of time.
3. Add manganese (IV) oxide into the round bottomed flask and repeat the procedure. Observe and record the volume of the gas as shown in table 3.5 below.

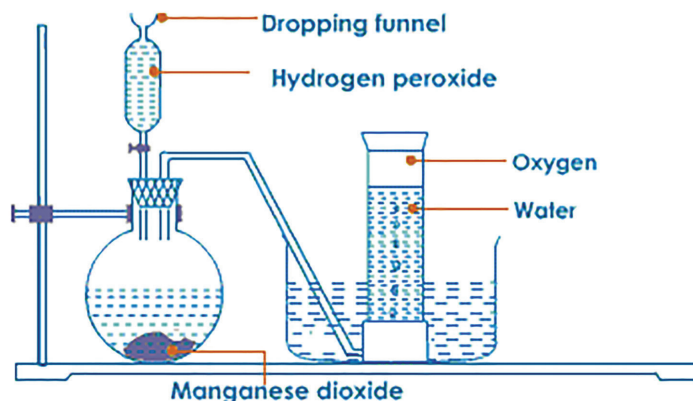

**Fig 3.7: Decomposition of hydrogen peroxide using manganese (IV) oxide**

Mass of manganese dioxide before \_\_\_\_\_.

Mass of manganese dioxide after \_\_\_\_\_.

**Table 3.5 Experiment results of rate of oxygen volume product per time interval**

Time (seconds)	0.0	30.0	60.0	90.0	120.0	150.0	180.0	210.0	240.0	270.0
Volume of gas (cm <sup>3</sup> )										

### Activity Questions

- Plot a graph of volume of gas produced against time (x-axis)
  - On the same axes, plot a graph of the uncatalysed reaction.
  - Explain the changes in mass of manganese (IV) oxide before and after the reaction.
  - Write the chemical equation for the reaction above.
  - Suggest alternative catalyst that can be used in place of manganese (iv) oxide in this experiment.

### The Facts

A catalyst is a substance that alters the rate of reaction, that is, it increases the speed of a chemical reaction but remains chemically unchanged at the end of a reaction. Biological catalysts are called **enzymes**. A catalyst does not alter the amount of products formed but itself may be altered physically e.g. from solid to powder or to fine powder. Like biological enzymes, a catalyst only catalyses specific type of reactions.

Most industrial catalysts are transition metals or their compounds. Catalyst works by lowering the activation energy ( $E_a$ ) of the reactants. The catalyst lowers the activation energy ( $E_a$ ) by:

- Forming short-lived intermediate compounds called activated complex that break up to form the final products. It provides binding surface for the reactants bringing them closer to one another thereby lowering the activation energy required for fruitful collisions to occur.
- Providing the surface area on which reaction occurs.

A catalyst has no effect on the enthalpy of reaction  $\Delta H$  but only lowers the activation energy ( $E_a$ ). It thus do not affect whether the reaction is exothermic or endothermic. The energy level diagram below shows effect of catalyst on activation energy.

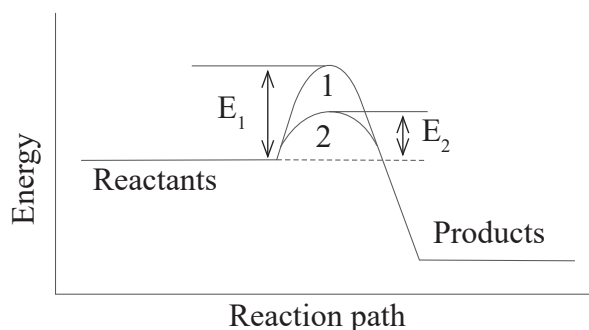

**Fig 3.8: Energy level diagram showing effect of a catalyst on the activation energy of reactions.**

### Work To Do

1. From the graph in Fig 3.8 above,
  - (i) interpret the information provided.
  - (ii) what can you conclude from the graph?
2. Cite some of the biological processes that are catalysed by enzymes. Name the reagents involved.

The following are some catalyzed industrial reaction processes.

#### (a) The Contact process

Vanadium pentoxide ( $V_2O_5$ ) or platinum(Pt) catalyses the oxidation of sulphur dioxide in one of the stages in the manufacture of sulphuric acid.

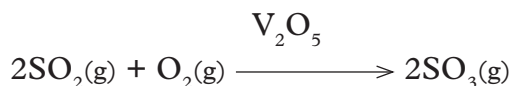

To reduce industrial cost of manufacture of sulphuric (VI) acid in the Contact process Vanadium(V) Oxide( $V_2O_5$ ) is used to speed up the rate of reaction to attain equilibrium quickly at its optimum conditions.

#### (b) Ostwald's process

Platinum promoted with rhodium catalyses the oxidation of ammonia to nitrogen monoxide and water during the manufacture of nitric acid.



#### (c) Haber process

Platinum or iron catalyses the combination of nitrogen and hydrogen to form ammonia gas.

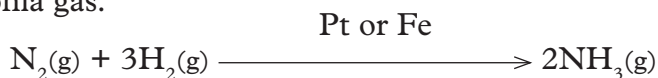

#### (d) Hydrogenation/hardening of oil to fat

Nickel (Ni) catalyses the hydrogenation of unsaturated compound containing double bond  $-C = C-$  or triple bond  $-C \equiv C-$  to saturated compounds with single bond. This process is used in the hardening of oil to fat.

**(e) Decomposition of hydrogen peroxide**

Manganese (IV) oxide speeds up the rate of decomposition of hydrogen peroxide to water and oxygen gas.

This reaction is used in the school laboratory for preparation of oxygen.

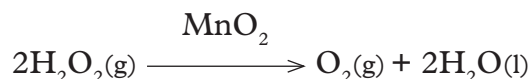

**(f) Reaction of metals with dilute sulphuric acid**

Copper (II) sulphate speeds up the rate of production of hydrogen gas from the reaction of zinc with dilute sulphuric acid.

This reaction is used in the school laboratory in preparation of hydrogen gas.



**Check your progress 3.2**

1. State three factors that affect the rates of reaction.
2. How does concentration of reactants affect the rate of a reaction?
3. Temperature increase affect rate of a reaction.
  - (a) Sketch a graph on the same axes, of a reaction of zinc with a dilute hydrochloric at 30°C and 60°C.
  - (b) What can you conclude from your graph?
4.
  - (a) Define the term catalyst.
  - (b) Describe how a catalyst increases the rate of reaction. Give an example of each.

### 3.4 Chemical equilibria

Study the picture below. How can the boy and girl balance?

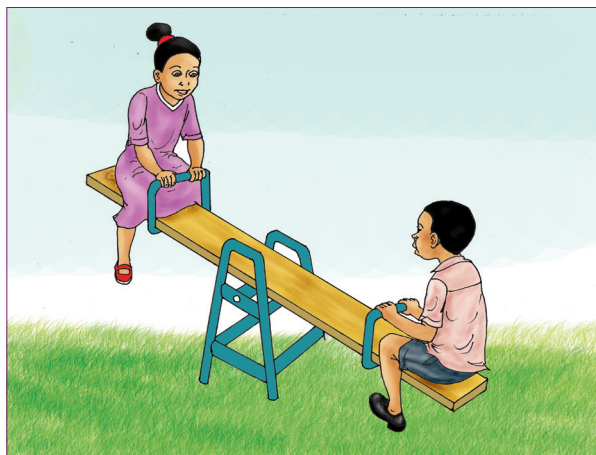
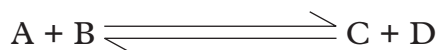

*Fig 3.9: Seesaw*

#### *The Facts*

Equilibrium is a state of balance. Chemical equilibrium is the state of balance between the reactants and products during reaction.

In some reactions, reactants form products and as soon as products are formed they start converting back to the reactants. Such reactions are said to be reversible and often they occur under suitable conditions.



Examples of reversible reactions

- (a) Reversible physical changes
- (b) Reversible chemical changes
- (c) Dynamic equilibrium

#### **(a) Reversible physical changes**

Reversible physical change is one which involves:

- (i) Change of state from solid, liquid, gas or aqueous solutions to another state. States of matter are interconvertible and a reaction involving a change from one state can be reversed back to the original.
- (ii) Colour changes. Some substances change their colours without change in chemical composition, for example zinc oxide. Zinc oxide is white when cold but changes to yellow when heated and back to white on cooling.

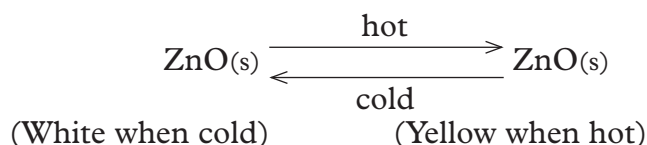

### (b) Reversible chemical reactions

These are reactions that involve a chemical change of the reactants. The product can be reversed back to the recombining elements or compounds, for example heating of hydrated copper (II) sulphate crystals.

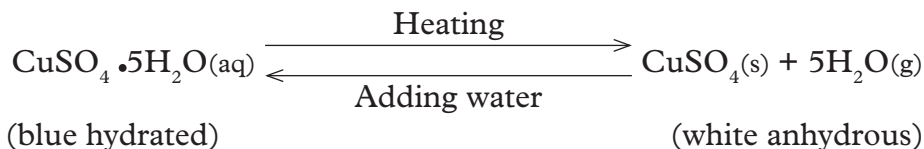

The water seen in the equation is the water of crystallisation which is chemically combined with the copper (II) sulphate in its hydrated condition.

### (c) Dynamic equilibria

This is a condition in which the forward reaction is equal to the backward reaction in a reversible reaction. This type of reaction occurs in a closed system. At the beginning of a reaction, the reactants are decreasing in concentration with time while the products are increasing in concentration with time. After some time a state of balance is reached between the reactants and the products concentration.

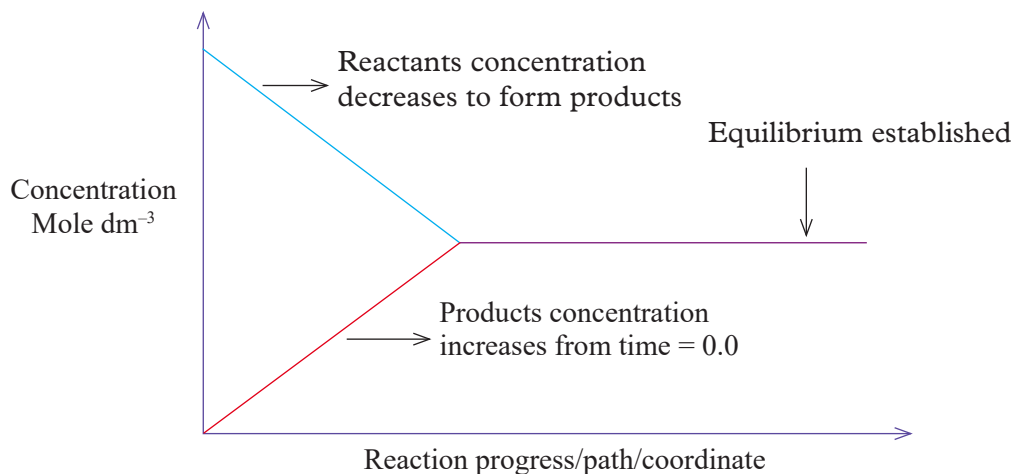

**Fig 3.10: Sketch showing the changes in concentration of reactants and products in a closed system**

A dynamic equilibrium is therefore a state of balance between the rate of formation of products and that of the change of products back to reactants in the same reaction. This state of balance continues to exist until the reactants or products are disturbed.

### **Individual Task**

1. In your own words, describe the dynamic equilibrium using the words “forward reaction” and “backward reaction”. Explain the meanings of these words.
2. Do you think in an open system, the dynamic equilibrium can be achieved? Give reasons for your answer.

The influence of different factors on a dynamic equilibrium was first investigated in 1850-1936 by French Chemist Louis **Henry Le Chatellier**. His findings were later called Le Chatelliers Principle which states that:

*“If a change or stress is applied to a system in dynamic equilibrium, the system readjusts so as to oppose the change or remove the stress”*

Le Chatelliers Principle is applied in determining the effect of several factors on systems at dynamic equilibrium. The following are the main factors that affect systems at dynamic equilibrium:

- (a) Concentration
- (b) Pressure
- (c) Temperature
- (d) Catalyst

### **Effect of concentration on dynamic equilibrium**

#### **Activity 3.6**

***To investigate the influence of alkali/acid on bromine water in an equilibrium mixture***

#### ***Apparatus and reagents***

10 ml measuring cylinder, boiling tube, dropper, Bromine water, 2M sodium hydroxide, 2M sulphuric acid.

**CAUTION:** This preparation should be done in a fume chamber or open air. Bromine vapours are poisonous.

#### **Procedure**

1. Prepare bromine water to use in the activity.
2. Measure 4 cm<sup>3</sup> of bromine water into a boiling tube. Note its colour.
3. Add three drops of 2M sulphuric acid. Note any colour change.
4. Add seven drops of 2M sodium hydroxide solution. Note any colour change.

### Activity questions

- (i) What was observed when the sulphuric acid was added?
- (ii) What was observed when sodium hydroxide was added?
- (iii) How can you explain the observations made in the experiment above.
- (iv) Suggest how you would prepare 1% bromine water in this activity.

### The Facts

When distilled water is added, an equilibrium exists between bromine liquid ( $\text{Br}_2(\text{aq})$ ) and the bromide ion ( $\text{Br}^-$ ), hypobromite ion ( $\text{OBr}^-$ ) and hydrogen ion ( $\text{H}^+$ ) as follows:

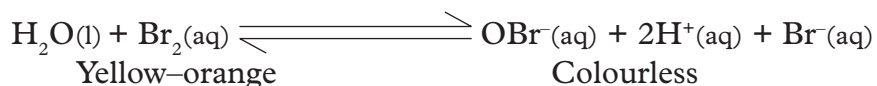

The addition of an acid ( $\text{H}^+$ ) ions to the equilibrium mixture, increases the concentration of ( $\text{H}^+$ ) ions on the product side. This makes the equilibrium to shift backwards to the left to remove the excess  $\text{H}^+$  ions causing the colour of the solution mixture to be more yellow.

When sodium hydroxide is added it introduces, hydroxide ions ( $\text{OH}^-$ ) to the equilibrium mixture, the  $\text{OH}^-$  ions reacts with hydrogen ions ( $\text{H}^+$ ) on the product side to form water.

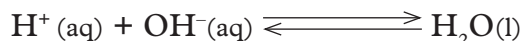

This decreases the concentration of the  $\text{H}^+$  ions on the product side. This causes a shift of the equilibrium to the right favouring forward reaction to replace  $\text{H}^+$  ions. This makes the solution mixture become colourless.

An increase or decrease in concentration of reactants or products of a reaction which is at equilibrium introduces stress in the system. From Le Chatelliers principle the system readjusts so as to remove the excess or increases the affected concentration.

### Group Task

1. In groups of three, suggest other examples of reactions where effect of concentration on the equilibrium can be demonstrated. Compare your findings with other groups.
2. Differentiate between static equilibrium and dynamic equilibrium. Give example for each.
3. Explain the significance of correct use of the following symbols in reversible reactions.

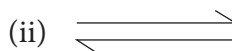
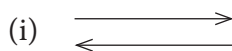



## Class Activity

As a class design, plan and conduct the following experiments.

- (i) Heating of hydrated copper (II) sulphate and after some time of cooling water is added again.
- (ii) Using potassium chromate (VI) solution to demonstrate existence of chemical equilibrium, suggest the reagents you need for the experiment.

## Activity questions

Chromate ( $\text{CrO}_4^{2-}$ ) ions in solution are yellow while dichromate (VI)/ $\text{Cr}_2\text{O}_7^{2-}$  ions in solution are orange. Use the equilibrium equation below to answer the questions that follow.

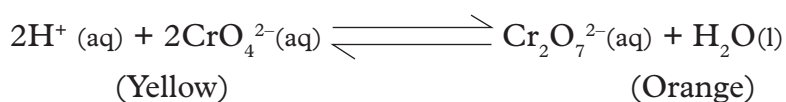

- (a) What do you think will be the colour at the equilibrium?
- (b) What will be the effect of addition of an acid to the equilibrium? Explain.
- (c) What will be effect of addition of potassium hydroxide to the equilibrium? Explain.
- (d) In the heating of copper (II) sulphate and adding water after some time bring colour change. Do you consider this as example of dynamic equilibrium? Give reasons for your answer.
- (e) The changing of colour of litmus solution in acidic and basic solution, do you think it a reversible equilibrium reaction?

## The Facts

Altering the concentration of any one of the components of the equilibrium mixture disturbs the equilibrium by affecting the rate of forward or reverse reaction. Hence the reaction proceeds predominantly in that direction until a new equilibrium is established.

## Effect of pressure on dynamic equilibrium

Pressure affects only gaseous reactants and products. Increase in pressure shifts the equilibrium towards the side with less number of molecules (volume) so as to reduce the pressure. Decrease in pressure shifts the equilibrium to produce more gas molecules until the state of balance is reached.

If the products and reactants have equal numbers of molecules then pressure has no effect on the equilibrium position.

The following examples show the influence of pressure on dynamic equilibrium.

### (i) Nitrogen dioxide/dinitrogen tetroxide mixture

Nitrogen dioxide and dinitrogen tetroxide can exist in dynamic equilibrium in a closed system. Nitrogen dioxide is a brown gas. Dinitrogen tetroxide is a yellow gas.

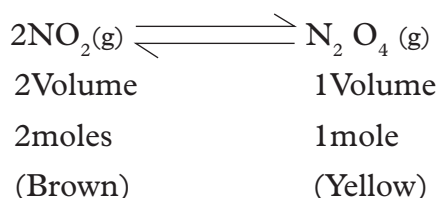

From the equation above, we can say 2 volumes of nitrogen dioxide decomposes to form one volume of dinitrogen tetroxide. When the reaction is at equilibrium an increase in pressure shifts the equilibrium to the right favouring forward reaction in order to remove the excess gas molecules of  $\text{NO}_2$  introduced into the system.

The equilibrium mixture become more yellow.

Decrease in pressure shifts the equilibrium to the left favouring backward reaction to produce more of the gas molecules. The equilibrium mixture becomes more brown.

### (ii) Iodine vapour-hydrogen gas/hydrogen iodide mixture

Pure hydrogen gas reacts with iodine vapour to form hydrogen iodide gas. An equilibrium is established as follows:

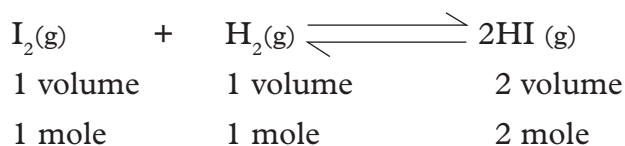

The total molecules on the reactant side are 2 volumes of iodine and hydrogen gas, forming two volumes of hydrogen iodide gas. Change in pressure thus has no effect on position of equilibrium.

### Discussion corner!

1. In groups of two, identify and write down some of the industrial processes experiencing dynamic equilibrium that can be affected by pressure factor.
2. Explain how you think the knowledge of effect of pressure on an equilibrium is utilized in the industrial processes you have identified in (1) above.
3. Using the knowledge acquired about Le Chatelier's principle, explain the effect of pressure on the reactions indicated by the following equations.

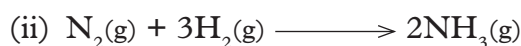
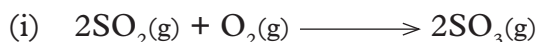

### Effect of Temperature on dynamic equilibrium

#### Review corner

1. Suggest some of the chemical and biological processes where temperature increase is important.
2. Differentiate between exothermic and endothermic reaction. In your judgement, how can you justify the effect of temperature on these reactions?

#### Activity 3.7

*To demonstrate the effect of temperature on equilibrium of nitrogen dioxide and dinitrogen tetraoxide*

##### **Apparatus and reagents**

Flat bottomed flask, thistle funnel, delivery tube, cork, test-tube, source of heat, copper turnings and concentrated nitric acid.

CAUTION:  $\text{NO}_2$  is poisonous. The activity should be carried out in fume cupboard.

##### **Procedure**

1. Place a few pieces of copper turnings in a round bottomed flask and arrange the apparatus as shown below.
2. Using a thistle funnel, add concentrated nitric acid to the copper turnings dropwise.
3. Collect the gas produced in a test tube fitted with a cork.
4. Warm the test tube and observe any colour changes.
5. Now cool the test tube in ice-cold water and note any colour changes.

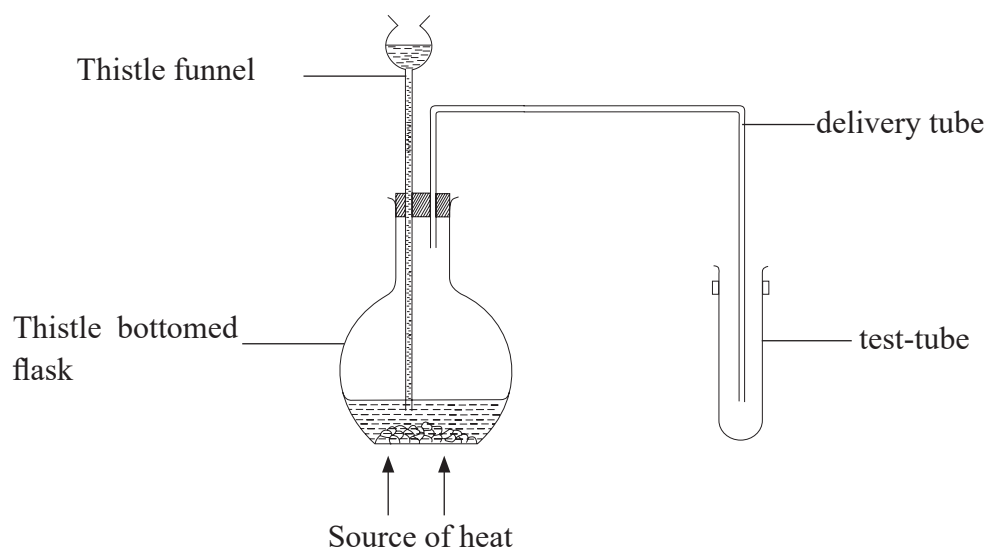

**Fig 3.11: Effect of temperature on an equilibrium**

### Activity questions

1. What is the colour of the gas collected?
2. What is observed when the test-tube is warmed? Explain.
3. What is observed when the test-tube is cooled? Explain.
4. Write the chemical equation for the reaction in above activity.

### The Facts

When a chemical reaction is at equilibrium a change in temperature may affect the balance depending on whether the equilibrium mixture is either exothermic or endothermic. A decrease in temperature favours the reaction that liberate heat (exothermic reaction). But an increase in temperature favours an endothermic reaction. Endothermic reaction are thus favoured by high temperatures while exothermic reaction are favoured by low temperatures.

If an equilibrium mixture is neither exothermic nor endothermic, then a change in temperature has no effect on the equilibrium position.

Nitrogen dioxide and dinitrogen tetraoxide can exist in dynamic equilibrium in a closed test tube.

Nitrogen dioxide is a brown gas. Dinitrogen tetraoxide is a yellow gas.

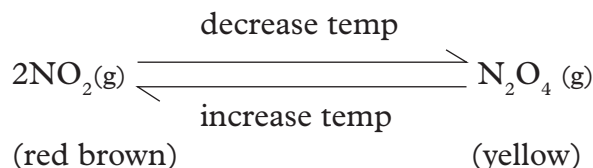

The equilibrium shifts to the right at lower temperatures favouring forward reaction. This leads to nitrogen (IV) oxide being converted to dinitrogen tetraoxide giving the gas its yellow colour. This shows that the forward reaction is exothermic reaction.

When the temperatures are increased the equilibrium shifts to the left and the dinitrogen tetraoxide is converted back to nitrogen (IV) oxide i.e. the backward reaction is favoured. The colour of the gas changes to dark brown.

### Effect of catalysts on dynamic equilibrium

A catalyst has no effect on the position of equilibrium. It only speeds up the rate of attainment of it. For example; esterification of alkanols and alkanolic acids naturally take place in fruits. In the laboratory concentrated sulphuric acid is used to catalyse such reactions. The equilibrium mixture forms the ester faster but the yield does not increase.

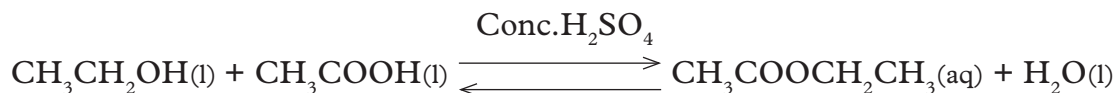

### Check your progress 3.3

1. State two distinctive features of a dynamic equilibrium.
2. Explain the effect of increase in pressure on the following:



3. Explain the effect of increasing temperature on the following:

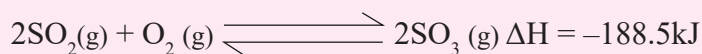

4. 5 g of brass of an alloy of copper and zinc was put into a flask containing dilute hydrochloric acid. The flask was then placed on an electronic balance. The readings on the balance were recorded as shown in the table below.

**Table 3.6: Readings on the balance at given time intervals**

Time (seconds)	Mass of flask (grams)	Loss in mass (grams)
0	400	
20	399.50	
40	399.12	
60	398.84	
80	398.66	
100	398.54	
120	398.50	
140	398.50	
160	398.50	

- Complete the table by calculating the losses in mass.
  - What does the “400” gram reading on the balance represent?
  - Plot a graph of loss in mass against time (x-axes).
  - Explain the shape of your graph.
5. List and explain three characteristics of dynamic equilibrium.

## 3.5 Electrochemistry

### Group Task

Study the photographs below.



A

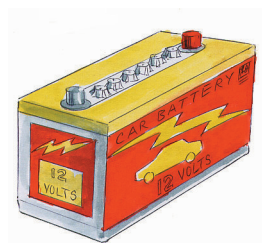

B

- In groups of three, discuss the importance of the items shown in the photographs above. How do they work?
- Can you suggest other consumer products that use the same working principle? Have you ever wondered how dry cells provide electric energy? How do you think, the cell works?

## The Facts

Electrochemistry can be defined as the study of electricity and how it relates to chemical reactions. Electrochemistry therefore deals mainly with:

- (i) Redox reactions
- (ii) Electrochemical (voltaic) cell
- (iii) Electrolysis (electrolytic) cell

### Redox reactions

A redox reaction is a reaction in which oxidation and reduction take place simultaneously.

### Individual Task

Using your previously acquired knowledge,

1. Cite some redox reactions you have performed in the school laboratory before.
2. Define oxidation agent and reducing agent.
3. Give examples of oxidising process and reduction process.

## The Facts

**Oxidation** can be defined as follows:

1. Addition of oxygen to a substance
2. Removal of hydrogen from a substance.
3. Loss of electrons by a substance.

**Reduction** is defined as

1. Removal of oxygen from a substance.
2. Addition of hydrogen to a substance
3. Gain of electron(s).

Examples of redox reactions

(i) *In terms of oxygen transfer*

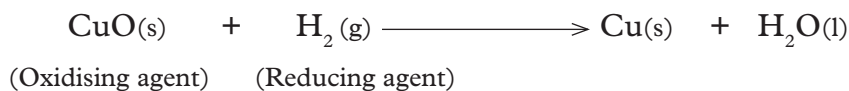

(ii) *In terms of hydrogen transfer*

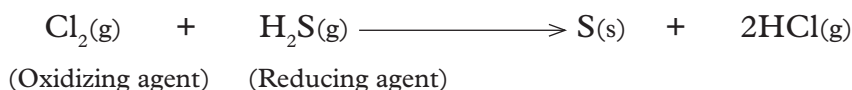

(iii) *In terms of electron transfer*



(Oxidizing agent) (Reducing agent)

In regard to electron transfer there is both gain and donation of electrons in redox reactions. In redox reactions, the oxidising agent gets reduced while its reducing agent becomes oxidised.

## Electrochemical (voltaic) cell

When a metal rod is put into a solution of its own salt, the metal partly ionizes and dissolves into the solution. The ions move into the solution leaving electrons on the surface of the metal rod. The **metal** rod becomes therefore **negatively** charged while its own **solution positively** charged. As the positive charges of the solution increase, some of them recombine with the electrons to form back the metal atom.

When a metal rod is put in a solution of its own salt, it forms a **halfcell**. The tendencies of metals to ionize differ from one metal to the other. The difference can be measured by connecting two half cells to form an electrochemical (voltaic) cell. The solutions of the two half cells are connected by a salt bridge. **A salt bridge** can be made up of filter paper soaked in a soluble salt such as potassium nitrate. The salt to be used in salt bridge must not react with the electrolyte in the cell.

The salt bridge has the following functions:

- (i) Completes the circuit of the cell.
- (ii) Provides ions to balance the ones produced and those consumed during the reactions.

The metal rods are connected by connecting wires.

### Activity 3.8

#### *To compare the relative tendency of metals to ionize*

#### **Apparatus and reagents**

1 M zinc sulphate, 100 cm<sup>3</sup> beaker, zinc plate, 01 M Copper (II) Sulphate, copper plate, voltmeter, filter paper, potassium nitrate.

#### **Procedure**

1. Place 50 cm<sup>3</sup> of 1M zinc sulphate in 100 cm<sup>3</sup> beaker. Put a cleaned zinc plate into its salt solution.
2. Place 50 cm<sup>3</sup> of 1M copper (II) sulphate in another 100 cm<sup>3</sup> beaker.
3. Put a clean copper plate of equal area (same length x width) as that of zinc into its solution.



4. Connect the two metals to a voltmeter using connecting wires. Dip a folded filter paper into a solution of potassium nitrate until it soaks.
5. Use the folded soaked filter paper to connect the two solutions in the beakers. The whole set up should be as below.

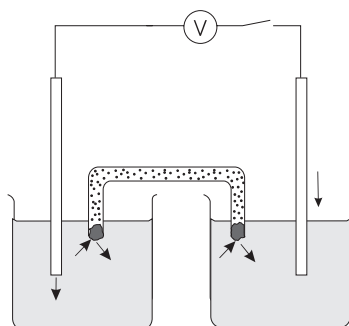

### Activity questions

1. What is observed on the voltmeter?
2. What is observed in the half cell with copper sulphate solution?
3. What observation is made on the two metal rods after some time?
4. What can you conclude from this investigation?

### The Facts

When zinc halfcell is connected to the halfcell of copper, zinc rod dissolves faster into the solution, that is, it diminishes. This is because zinc has a higher tendency to lose electrons compared to copper. The zinc rod therefore undergoes **oxidation**. Since there is a higher accumulation of electrons at the zinc rod, it is therefore **negatively** charged with reference to the copper rod. In the copper halfcell on the other hand the blue colour of the copper sulphate solution fades and a brown deposit is observed on the copper rod. Since the copper rod has a lower concentration of electrons it is **positively charged** in reference to the zinc rod. The electrons produced from the zinc rod are transferred to the copper rod through the connecting wires. The copper (II) ions in the copper halfcell therefore undergo **reduction** by accepting the incoming electrons to form copper atoms. This reduces the concentration of  $\text{Cu}^{2+}$  ions in the copper electrolyte solution hence the solution colour fades. The copper rod also increases.

The metal rods act as the electrodes of the cell. The electrode over which oxidation takes place is known as the **anode** while the electrode over which reduction takes place is known as the **cathode**. There is deflection on the voltmeter indicating flow of current. This value on the voltmeter is known as the **electromotive force (emf)** of the cell.

- Half reaction at the anode



Oxidation is taking place

- Half reaction at the cathode

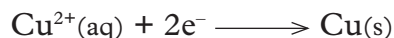

Reduction is taking place

- Overall cell reaction

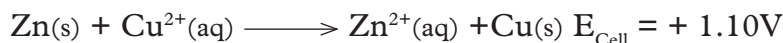

The cell diagram representation is as shown

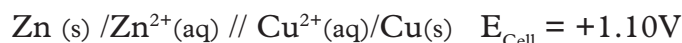

When writing cell diagram representations, the half-cell in which oxidation takes place (more reactive metal) should always be on the left hand side, while that in which reduction takes place should always be on the right hand side.

### Group Task

1. Repeat the above procedure with your classmates but use iron in place of zinc dipped in an iron salt solution. Record the observations made. Try to explain the observations you have made.
2. Also measure the voltage of electrochemical cells using different electrodes. Record your observations.

### Activity question

1. How would you justify the different voltage given by the different electrodes?
2. Why must the same size electrodes be used in these experiments?

### Standard electrode potential ( $E^{\ominus}$ )

The **standard** electrode potential ( $E^{\ominus}$ ) is obtained if **hydrogen** halfcell is used as **reference**. The standard electrode potential ( $E^{\ominus}$ ) consist of inert platinum electrode immersed in 1M solution of sulphuric acid ( $\text{H}^{+}$ ) ions. Hydrogen gas is bubbled on the platinum electrodes at standard conditions of:

- (i) A temperature of 25°C.
- (ii) Atmospheric pressure of 101300Pa/101300Nm<sup>-2</sup>/1atm/760mmHg/76 cmHg.
- (iii) A concentration of 1M (1mol dm<sup>-3</sup>) of sulphuric acid ( $\text{H}^{+}$ ) ions and 1M(1mol dm<sup>-3</sup>) of the other half cell.

Hydrogen is **adsorbed** onto the **surface** of the platinum. An **equilibrium** exist between the adsorbed layer of molecular hydrogen and  $\text{H}^{+}$  ions in solution to form

a half cell.

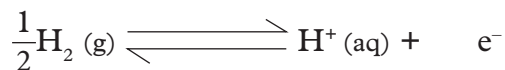

The half cell representation is:

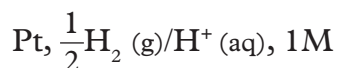

The standard electrode potential ( $E^\ominus$ ) is thus defined as the potential difference for a cell comprising of a particular element in contact with 1M solution of its own ions and the standard hydrogen electrode.

If the other electrode has a **higher** tendency to lose electrons than the hydrogen electrode, the electrode is therefore **negative** with respect to hydrogen electrode and its electrode potential has **negative** ( $E^\ominus$ ) values.

If the other electrode has a **lower** tendency to lose electrons than the hydrogen electrode, the electrode is therefore **positive** with respect to hydrogen electrode and its electrode potential has **positive** ( $E^\ominus$ ) values.

### Discussion corner!

1. In your own judgement, explain why electrons move to the electrodes and not the ions.
2. Suggest why it is not possible to measure electrode potential of a single half-cell. Why is this measurement called electrode potential?

Table 3.7 Standard electrode potential ( $E^\ominus$ ) of some reactions

Reaction	( $E^\ominus$ ) values in volts
$\text{F}_2(\text{g}) + 2\text{e}^- \longrightarrow 2\text{F}^-(\text{aq})$	+2.87
$\text{H}_2\text{O}_2(\text{aq}) + 2\text{H}^+(\text{aq}) + 2\text{e}^- \longrightarrow 2\text{H}_2\text{O}(\text{l})$	+1.77
$\text{MnO}_4^-(\text{aq}) + 4\text{H}^+(\text{aq}) + 3\text{e}^- \longrightarrow \text{MnO}_2(\text{s}) + 2\text{H}_2\text{O}(\text{l})$	+1.70
$2\text{HClO}(\text{aq}) + 2\text{H}^+(\text{aq}) + 2\text{e}^- \longrightarrow \text{Cl}_2(\text{aq}) + 2\text{H}_2\text{O}(\text{l})$	+1.59
$\text{MnO}_4^-(\text{aq}) + 4\text{H}^+(\text{aq}) + 5\text{e}^- \longrightarrow \text{Mn}^{2+}(\text{aq}) + 2\text{H}_2\text{O}(\text{l})$	+1.51
$\text{Cl}_2(\text{g}) + 2\text{e}^- \longrightarrow 2\text{Cl}^-(\text{aq})$	+1.36
$\text{MnO}_2(\text{s}) + 4\text{H}^+(\text{aq}) + 2\text{e}^- \longrightarrow \text{Mn}^{2+}(\text{aq}) + 2\text{H}_2\text{O}(\text{l})$	+1.23
$\text{Br}_2(\text{aq}) + 2\text{e}^- \longrightarrow 2\text{Br}^-(\text{aq})$	+1.09

Reaction	( $E^{\ominus}$ ) values in volts
$\text{NO}_3^- (\text{aq}) + 2\text{H}^+ (\text{aq}) + \text{e}^- \longrightarrow \text{NO}_2 (\text{g}) + \text{H}_2\text{O} (\text{l})$	+0.80
$\text{Ag}^+ (\text{aq}) + \text{e}^- \longrightarrow \text{Ag} (\text{s})$	+0.80
$\text{Fe}^{3+} (\text{aq}) + \text{e}^- \longrightarrow \text{Fe}^{2+} (\text{aq})$	+0.77
$2\text{H}^+ (\text{aq}) + \text{O}_2 (\text{g}) \longrightarrow \text{H}_2\text{O}_2 (\text{aq})$	+0.68
$\text{I}_2 (\text{aq}) + 2\text{e}^- \longrightarrow 2\text{I}^- (\text{aq})$	+0.54
$\text{Cu}^{2+} (\text{aq}) + 2\text{e}^- \longrightarrow \text{Cu} (\text{s})$	+0.34
$2\text{H}^+ (\text{aq}) + 2\text{e}^- \longrightarrow \text{H}_2 (\text{g})$	<b>+0.00</b>
$\text{Pb}^{2+} (\text{aq}) + 2\text{e}^- \longrightarrow \text{Pb} (\text{s})$	-0.13
$\text{Fe}^{2+} (\text{aq}) + 2\text{e}^- \longrightarrow \text{Fe} (\text{s})$	-0.44
$\text{Zn}^{2+} (\text{aq}) + 2\text{e}^- \longrightarrow \text{Zn} (\text{s})$	-0.77
$\text{Al}^{3+} (\text{aq}) + 3\text{e}^- \longrightarrow \text{Al} (\text{s})$	-1.66
$\text{Mg}^{2+} (\text{aq}) + 2\text{e}^- \longrightarrow \text{Mg} (\text{s})$	-2.37
$\text{Na}^+ (\text{aq}) + \text{e}^- \longrightarrow \text{Na} (\text{s})$	-2.71
$\text{K}^+ (\text{aq}) + \text{e}^- \longrightarrow \text{K} (\text{s})$	-2.92

Note:

- $E^{\ominus}$  values generally show the possibility of a reduction process (oxidizing strength). The list obtained in table 3.7 is called **electrochemical series**.
- The element (species) in the half cell with the highest positive  $E^{\ominus}$  value easily gain electrons. It is thus the strongest oxidizing agent and its reduction process is highly possible. The species in the half cell with the more negative  $E^{\ominus}$  value means it easily loses electrons. It is thus the strongest reducing agent and its reduction process is the least possible/feasible.
- The overall redox reaction is possible if it has a positive (+)  $E^{\ominus}$ . If the overall redox reaction is not possible it has a negative(-)  $E^{\ominus}$ .

To make it easy for us to understand, let us put some of the E. values in Table 3.7 in a number line as shown below.

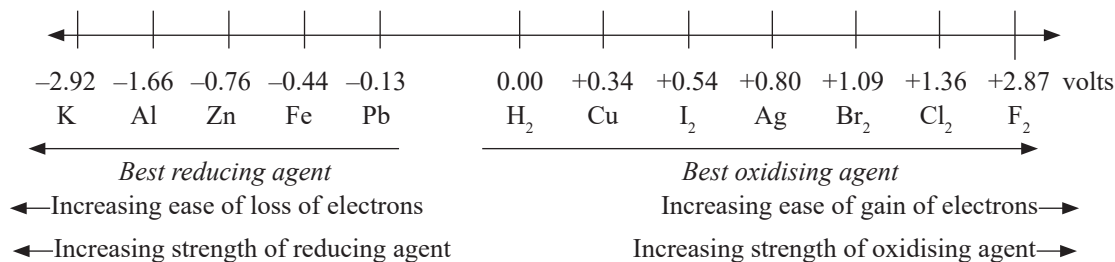

**Fig 3.10: Some electrode potentials on the number line**

What is the use of electrode potentials?

- to calculate e.m.f of a cell.
- to predict whether or not a redox reaction will occur.

In dealing with calculations and writing equations of electrochemical reactions, observe the following.

- / – A single vertical line indicates a change in state or place between the metals and their ions e.g.  $\text{Zn(s)}/\text{Zn}^{2+}(\text{aq})$ .
- Within a half-cell, the reactants are written before the product e.g. zinc metal (reactant dissolves to form zinc ions (product)).
- Concentration of aqueous solutions are written in brackets after the symbol of the ions.
- // or /// (double vertical lines or dotted vertical lines) represents salt bridge or porous barrier connecting the two half-cells.
- By convention, the more electropositive electrode (one that does not ionise easily) is put on the right-hand side.

Thus, the emf of the cell is given by:

$$E_{\text{Cell}} = E^{\ominus}(\text{right-hand side electrode}) - E^{\ominus}(\text{left-hand side electrode})$$

### Calculations of the $E^{\ominus}$ using reduction potentials

We must always remember when calculating the e.m.f of the cell, to use the following expression.

$$E_{\text{Cell}} = E^{\ominus}(\text{right hand side}) - E^{\ominus}(\text{left hand side})$$

#### Worked Example 1

Use the  $E^{\ominus}$  value in table 3.6 for the following workings.

Calculate the  $E^{\ominus}$  value of a cell made of:

Zn and Cu cell

#### Solution

From the Table 3.6:

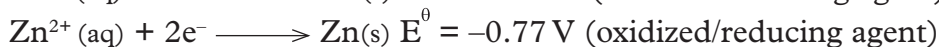
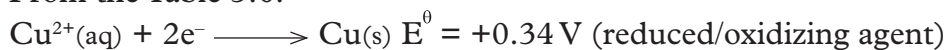

$$\text{Overall } E^{\ominus} = E^{\ominus}_{\text{reduced}} - E^{\ominus}_{\text{oxidized}}$$

Substituting:

$$\text{Overall } E^{\ominus} = +0.34 - (-0.77) = +1.11 \text{ V}$$

Overall redox equation:

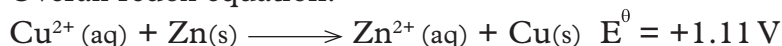

Overall cell diagram representation:

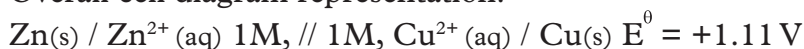

Remember in writing overall cell diagram representation, the cell representing the electrode losing electrons comes first.

### Worked Example 2

Determine the  $E^\ominus$  value of the following

Mg and Cu cell

### Solution

From Table 3.7:

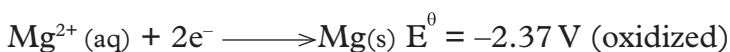
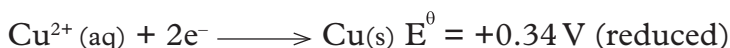

$$\text{Overall } E^\ominus = E^\ominus_{\text{reduced}} - E^\ominus_{\text{oxidized}}$$

Substituting:

$$\text{Overall } E^\ominus = +0.34 - (-2.37) = +2.71 \text{ V}$$

Overall redox equation:

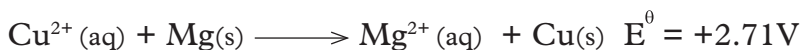

Overall cell diagram representation:



### Check your progress 3.4

1. State the function of salt bridge in electrochemical cell.
2. What is a half-cell?
3. Using the reduction potentials in table 3.7 calculate the **e.m.f** of the following cells.
  - (a) Ag and Pb
  - (b) Chlorine and Bromine
  - (c) Identify the strongest oxidizing agent and the strongest reducing agent.
4. Identify the applications of a voltaic cell in our day to day life.
5. The letters A,B,C,D, and G given below do not represent actual symbols of elements. Use the  $E^\ominus$  values given to answer the questions that follow.

Electrode reaction	$E^{\circ}$ (volts)
$A^{2+}(aq) + 2e^{-}$ ——— $A(s)$	-2.90
$B^{2+}(aq) + 2e^{-}$ ——— $B(s)$	-2.38
$C^{+}(aq) + e^{-}$ ——— $\frac{1}{2}C_2(g)$	0.00
$D^{2+}(aq) + 2e^{-}$ ——— $D(s)$	+0.34
$G_2(g) + e^{-}$ ——— $G^{-}(aq)$	+2.87

- Which element is likely to be hydrogen? Give a reason for your answer.
- Which element is the strongest reducing agent? Give a reason for your answer.
- Write the representation of a cell obtained when A and D are combined and calculate e.m.f. of that cell.

### 3.6 Role of electricity in electrolysis

#### Review corner

In Form 2 you learnt about electrolysis and how it can be used to separate some salts. You are as well now knowledgeable about the application and roles of electrolysis in daily life.

Using your previously acquired knowledge;

- Explain the meaning of electrolysis, electrolyte and non-electrolyte.
- Briefly explain how and why electrolysis can be used in separation of salts.
- Can you justify why electrolytes in molten and aqueous state conduct electricity yet in solid state or when put in non-polar solvent they cannot. Also give reasons why non-electrolytes cannot conduct electricity.
- In your own opinion or judgement what is the role of water and electricity in electrolysis?

#### The Facts

#### Electrolysis (electrolytic cell)

*Electrolysis* is simply defined as the decomposition of a compound by passing an electric current through it. A compound that is decomposed by an electric current is called an electrolyte.

During electrolysis, the free ions are attracted to the electrodes. An electrode is a rod through which current enter and leave the electrolyte during electrolysis.

The **anode** is the electrode through which current enter the electrolyte or electrons leave the electrolyte. The negative electrode is called **cathode**. The cathode is the electrode through which current leave the electrolyte or electrons enter the electrolyte.

The diagram below shows an electrolytic cell. Identify the cathode and anode. During electrolysis which electrode would the cations and anions migrate to? Justify your answer. Which electrode does the current enter and electrons enter as well?

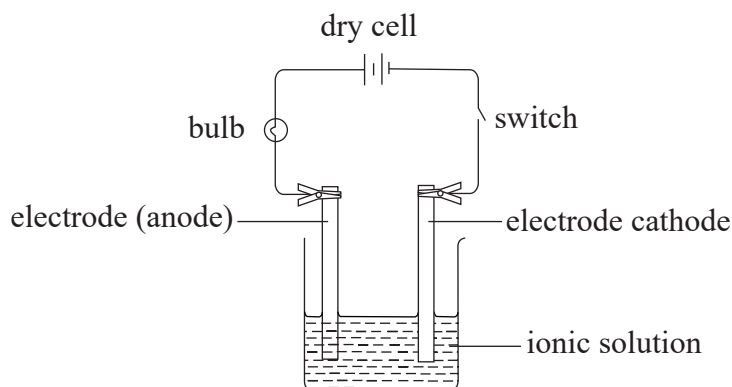

*Fig 3.12: An electrolytic cell*

During the electrolysis, free **anions** are attracted to the **anode** where they **lose** electrons to form **neutral** atoms or molecules. The free **cations** are attracted to the **cathode** where they **gain** electrons to form **neutral** atoms/molecules.

The neutral atoms or molecules form the **products** of electrolysis at the anode and cathode. This is called **discharge** at the electrodes.

### *Group Task*

1. In groups of three, discuss the similarities and differences between the electrochemical cell and electrolysis cell. Let each group make a presentation to the rest of the class.
2. From your above discussion, electro-chemical reaction can occur without electricity but electrolysis cannot take place without electricity. Agree or disagree. Explain your answer.



### 3.7 Role of water in electrolysis

Water is regarded as universal solvent because it dissolves most substances. It is called polar solvent because its molecules are polar. The oxygen is partially negative whereas hydrogen atom is partially positive. Because of this, the oxygen atoms are attracted by the positive ions of the solid on the surface while the hydrogen atoms are attracted by the solids negative ions. This attraction between the water molecules and the ions in the solid is so intense that it overcomes the forces of attraction holding the ions in the solid together. This leads to the solid eventually discolouring.

#### Check your progress 3.5

1. In the electrolysis of water, at which electrode will hydrogen be produced? Give reasons for your answer.
2. In preparing electrolytes for electrolysis, we either melt \_\_\_\_\_ compounds or dissolve them in \_\_\_\_\_?

# UNIT 4

## Composition of ores of some common metals and appropriate methods of extraction

### Learning outcomes

Knowledge and understanding	Skills	Attitudes
<ul style="list-style-type: none"><li>Name and know compositions of ores of some common metals and appropriate methods of extractions.</li></ul>	<ul style="list-style-type: none"><li>Use a range of sources to investigate the compositions of chief ores of some metals.</li><li>Design methods of extraction of metals.</li></ul>	<ul style="list-style-type: none"><li>Appreciate the importance of understanding the composition of ores to facilitate their extraction.</li></ul>

### Introduction

Study the photographs below



1. Justify their importance.
2. Name the minerals from which the above items are obtained. Identify the place the mineral ores are found in South Sudan if any, in Africa and the rest of the world.

## Review corner

Using your previously acquired knowledge;  
How do you extract metals from their chief ores.

In this unit we are going to learn about some common metals, the composition of their ores and how their reactivity and physical properties influence the method of extraction. For example, electrolysis is used in the extraction of reactive metals such as sodium, while less reactive metals like iron are extracted by reduction.

## Group Task

In groups of three, using acquired knowledge in Geography;

1. Explain the meaning of metal ore and how is the ore considered economically viable for mining.
2. Describe some of the methods of mining and the general process of extracting metals.
3. Write a report and make a presentation to the rest of the class.

## The Facts

### Extraction of metals

#### General method of extracting metals

Metals can be extracted from minerals found in form of rocks together with other materials eg. soil, sand etc in the earth's crust. A mineral is the useful part of the rock. Rocks from which metals can be extracted are called ores. Extraction of metals from their ores involves the following general processes.

- Removing the ore from the ground (mining)

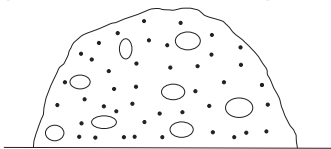

- Concentration of the ore

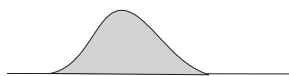

- Reduction of the ore to metal

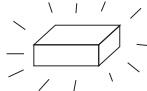

**Fig. 4.1: General process of extracting metals**

## 1. Getting the ore from the ground

The ore can be located near the surface of the earth or deeper into the earth's crust. If the ore is near the surface, **open-cast mining** or **quarrying** is used. If it is deeper into the earth's crust, then **deep mining** is used. Machines like excavators, crawlers, bulldozers, etc. are used during this process.

## 2. Concentration of the ore

The ore after mining is in lump form. It has to be crushed first into powder form. It is then concentrated. Concentrating the ore increases the percentage of the mineral or metal in it.

The methods used to concentrate the ore depends on the differences in physical or chemical properties between the mineral and the waste material found in the ore. These methods include froth floatation and chemical leaching.

### (a) Froth floatation

This method is used when the percentage of mineral in the ore is too small. In this process, the ground ore is mixed with water and oil and air blown into the mixture. Separation is possible because of the different densities of the materials.

This imparts an oil coat in every grain of the ore making it hydrophobic ('water hating'). This creates two layers. A froth forms on top with most of the minerals and the waste materials or impurities at the bottom. The top layer with the metal of interest is removed and dried in readiness for further processing.

### (b) Chemical leaching

The crushed ore is first dissolved in a chemical where only the ore can dissolve. The solution is then separated from the insoluble materials (which in this case, are considered to be impurities) and finally, the purified ore is crystallised out of the solution.

## 3. Reduction of the ore to metal

Once the ore has been concentrated, the metal of interest has to be extracted from the ore. The method of separation of the metal from the ore depends on the position of the metal in the electrochemical series. There are two major methods of obtaining the metal from the ore.

- **Reduction by carbon** – for moderately reactive metals with less negative electrode potentials e.g. zinc, iron etc.
- **Electrolysis** – for very reactive metals with high negative electrode potentials e.g sodium, potassium, calcium and aluminium.

Reduction by carbon cannot work for metals higher in electrochemical series than carbon. This is because carbon cannot displace the highly reactive metals from

their ores. However, electrolysis can be used to separate these metals from their fused ores. Note that the more reactive the metal is, the harder it is to extract. This is because they are very stable in their compounds.

The following is a summary of the way metals can be obtained from their concentrated ores depending on their position in the electrochemical series.

**Note:** The arrow indicates increase in ease of extraction.

<b>Metal</b>	<b>Extraction method</b>	
Potassium (K)	<b>Electrolysis</b>	<div style="display: flex; align-items: center;"> <div style="margin-right: 10px;">} </div> <div style="text-align: right;">                     Difficult to extract                 </div> </div>
Sodium (Na)		
Lithium (Li)		
Calcium (Ca)		
Magnesium (Mg)		
Aluminium (Al)		
Zinc (Zn)	<b>Reduction by carbon</b>	<div style="display: flex; align-items: center;"> <div style="margin-right: 10px;">} </div> <div style="text-align: right;">                     ↓                 </div> </div>
Iron (Fe)		
Tin (Sn)		
Lead (Pb)		
Copper (Cu)	These metals can be found uncombined in which case they are simply picked and washed as free metal. Copper and silver are often found as ores but they are extracted by roasting the ore.	<div style="display: flex; align-items: center;"> <div style="margin-right: 10px;">} </div> <div style="text-align: right;">                     ↓                 </div> </div>
Silver (Ag)		
Gold (Au)		
Platinum (Pt)		

### **Group Task**

In groups of four, discuss the effects of mining on the environment.

## 4.1 Sodium

### Natural occurrence

Sodium does not occur as free element due to its high reactive nature. It occurs in the following ores form.

- (i) Brine - a concentrated solution of sodium chloride  $[\text{NaCl}(\text{aq})]$  in salty seas and oceans.
- (ii) Rock salt - solid sodium chloride  $(\text{NaCl}(\text{s}))$
- (iii) Trona - sodium sesquicarbonate  $(\text{NaHCO}_3 \cdot \text{Na}_2\text{CO}_3 \cdot 2\text{H}_2\text{O})$
- (iv) Chile saltpeter - sodium nitrate  $(\text{NaNO}_3)$ .

### Extraction of sodium

The chief ore from which sodium is extracted is rock salt. Since sodium is a very reactive element it is only possible to extract it by electrolysis using Downs cell.

Rock salt (solid sodium chloride) is fused, i.e. heated to molten state in a chamber lined with fire bricks on the outside. Before fusing the ore it is crushed, unwanted impurities removed.

Sodium chloride having a high melting point of about  $800^\circ\text{C}$ , it is mixed with a little calcium chloride to lower its melting point to about  $600^\circ\text{C}$ .

### Downs process

It takes place in the Down's cell as illustrated in the set up below.

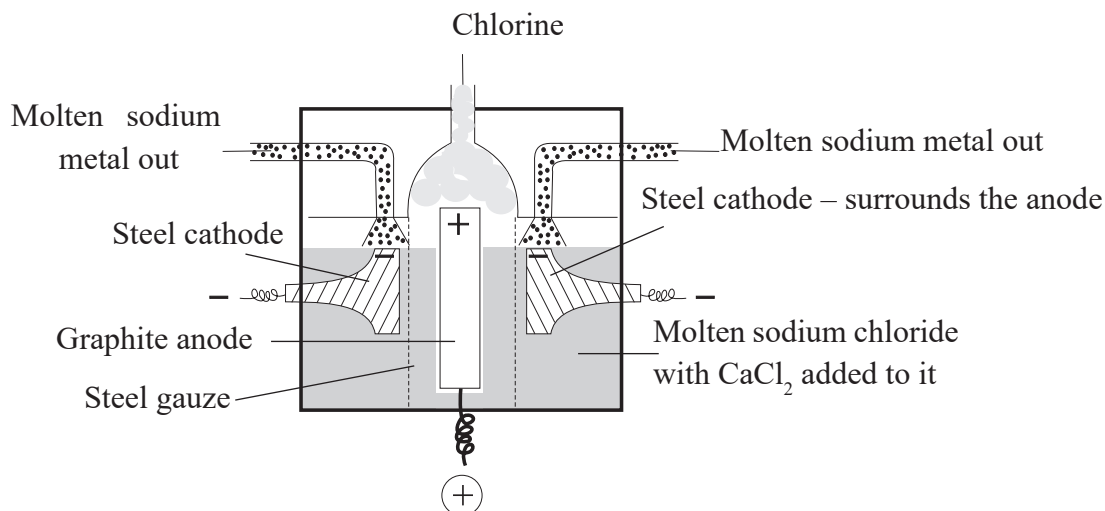

**Fig 4.2: Down's cell**

In molten state, sodium chloride is in its separate ions i.e.

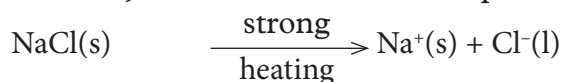

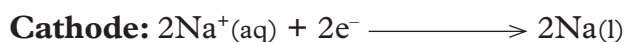

The sodium ions are attracted to the cathode where they gain electrons and are reduced to form sodium atoms (sodium metal).

Sodium is obtained in molten state since its melting point is lower than the temperatures in the cell. The molten sodium is also less dense than the electrolyte hence is tapped off at the top.

The steel diaphragm separates the cathode from the anode hence preventing the chlorine gas from recombining with the hot sodium.

### Discussion corner!

1. Why do you think the anode is made of steel but not carbon?
2. Do you think aqueous sodium chloride can be used in the Downs cell? Explain your answer.
3. What could be some of the environmental effects of extraction of sodium?
4. Mention some of the drawbacks of Down's process. Suggest how they have been tackled. Can you think of alternative ways?

### The Facts

The product obtained at the anode is chlorine gas, which react with sodium very vigorously to form sodium chloride. It is therefore important to keep the chloride gas away from the sodium in the cell. This is done using the steel gauze. Aqueous sodium chloride cannot be used in the Down's cell since hydrogen ions would be preferentially discharged instead of sodium ions.

### Research work

With two other classmates, using textbooks and from internet, describe and write notes on another method that can be used in extraction of sodium apart from use of the Down's cell process.

### Uses of sodium

1. Sodium vapour is used as sodium lamps to give a yellow light in street lighting.
2. Sodium is used in making very useful sodium compounds like;
  - (i) Sodium hydroxide(NaOH) e.g. used in soap making, concentration of aluminium ore

- (ii) Sodium cyanide( $\text{NaCN}$ )
  - (iii) Sodium peroxide( $\text{Na}_2\text{O}_2$ )
  - (iv) Sodamide( $\text{NaNH}_2$ )
3. An alloy of potassium and sodium is used as **coolant** in nuclear reactor.

### Group Task

- In pairs, describe the components and composition of Down's cell.
- Design a method of extraction of sodium from any one of its ores.
  - Using the method of extraction of sodium designed, which ore can be used in the extraction process?
  - Suggest some drawbacks for this method. How do you think these drawbacks can be overcome?
- Design, plan and conduct investigation to identify the composition of rock salt and trona.

### Check your progress 4.1

- Below is a simplified diagram of the Down's Cell used in the manufacture of sodium. Study it and then answer the questions that follow.

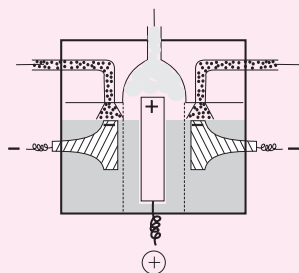

- What material is the anode made of? Give a reason.
  - What precaution is taken to prevent chlorine and sodium from recombination?
  - Write an ionic equation for the reaction in which chlorine gas is formed.
- In the Downs process, a certain salt is added to lower the melting point of sodium chloride from about  $800^\circ\text{C}$  to about  $600^\circ\text{C}$ .
    - Name the salt that is added.
    - State why it is necessary to lower the temperature.
  - Explain why aqueous sodium chloride is not suitable as an electrolyte for the manufacture of sodium in the Down's process.
  - Sodium metal reacts with air to form two oxides. Give the formulae of two oxides.



## 4.2 Aluminium

### Review corner

Using your previously acquired knowledge,

1. Describe some properties and uses of aluminium.
2. In your judgement, do you consider aluminium as very or less reactive element? Explain.

### Natural occurrence

Aluminium is the most common naturally occurring metal. It makes 7% of the earth's crust as:

- (i) Bauxite ore (Hydrated aluminium oxide,  $\text{Al}_2\text{O}_3 \cdot 2\text{H}_2\text{O}$ )
- (ii) Mica ore (Potassium aluminium silicate,  $\text{K}_2\text{Al}_2\text{Si}_6\text{O}_{16}$ )
- (iii) China clay ore (aluminium silicate,  $\text{Al}_2\text{Si}_6\text{O}_{16}$ )
- (iv) Corundum (Anhydrous aluminium, oxide ( $\text{Al}_2\text{O}_3$ ))

### Group Task

In groups of three, researching from books and internet, describe a method of investigation to distinguish between the various ores of aluminium.

### Extraction of aluminium from Bauxite (Halls cell process)

The main ore from which aluminium is extracted is **bauxite**.

The ore is mined by open-caste mining method/quarrying where it is scooped together with silica ( $\text{SiO}_2$ ) and iron(III)oxide ( $\text{Fe}_2\text{O}_3$ ) as **impurities**. Extraction process of aluminium is done in two main stages as follows.

### (i) Concentration of the ore

This stage is meant to remove the impurities in the ore. The ore is first ground and then dissolved in hot concentrated sodium hydroxide solution. The alkali dissolves both bauxite and silica. This is because bauxite is **amphoteric** while silica is **acidic**.

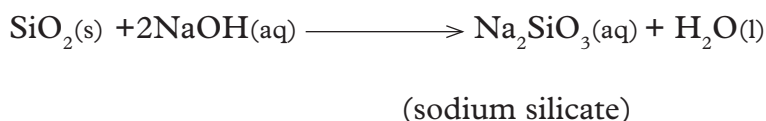
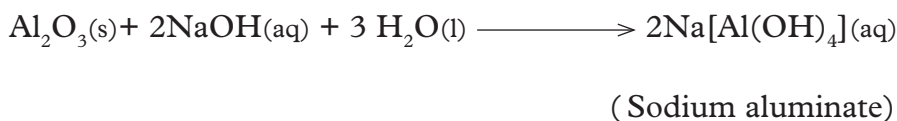

Iron(III)oxide ( $\text{Fe}_2\text{O}_3$ ) is filtered off as a residue since it does not react with the alkali.

Carbon dioxide is bubbled into the filtrate to precipitate aluminium hydroxide ( $\text{Al}(\text{OH})_3$ ). The mixture is then filtered to obtain aluminium hydroxide as residue. Silica remains in the solution as a filtrate of sodium silicate.

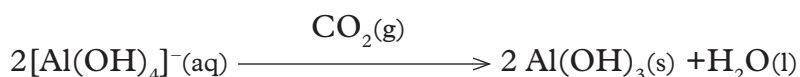

Aluminium hydroxide ( $\text{Al}(\text{OH})_3$ ) residue is then heated to produce pure aluminium (III)oxide( $\text{Al}_2\text{O}_3$ ).

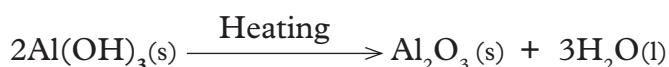

### (ii) Electrolysis process

Pure aluminium (III)oxide ( $\text{Al}_2\text{O}_3$ ) has a very high melting point of **2015°C**. A lot of energy is required to melt the oxide. It is therefore first dissolved in molten cryolite (sodium hexafluoroaluminate,  $\text{Na}_3\text{AlF}_6$ ) to lower the melting point to about 800°C. The molten electrolyte is then put into the Hall cell made up of a steel tank lined with carbon graphite and an anode suspended in the electrolyte.

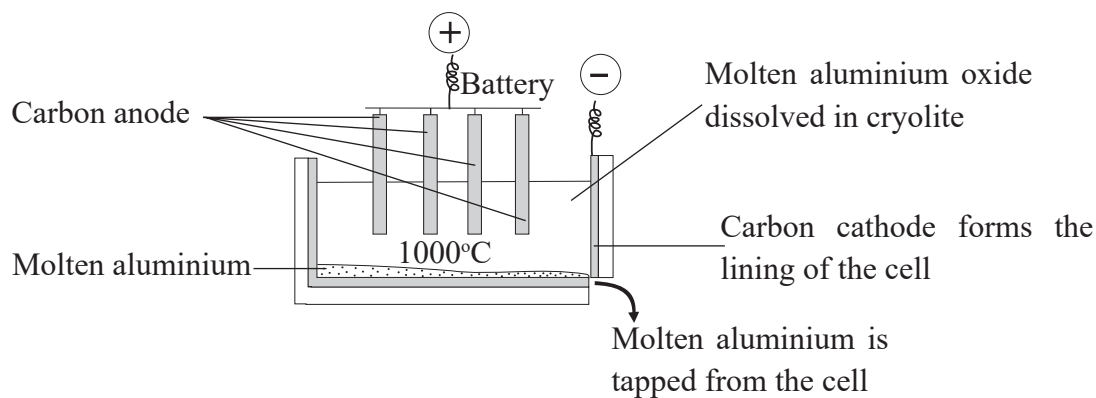

**Fig 4.3: Hall cell for extraction of Bauxite**

During the electrolysis, the reactions taking place at the electrode are as follows:

**(i) At the cathode;**



**(ii) At the anode;**

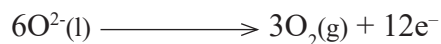

Aluminium being denser than the electrolyte therefore sink to the bottom of the Hall cell.

At this temperature, the oxygen produced at the anode reacts with carbon anode to form carbon dioxide gas that escapes to the atmosphere.



The anode is thus continuously replaced from time to time.

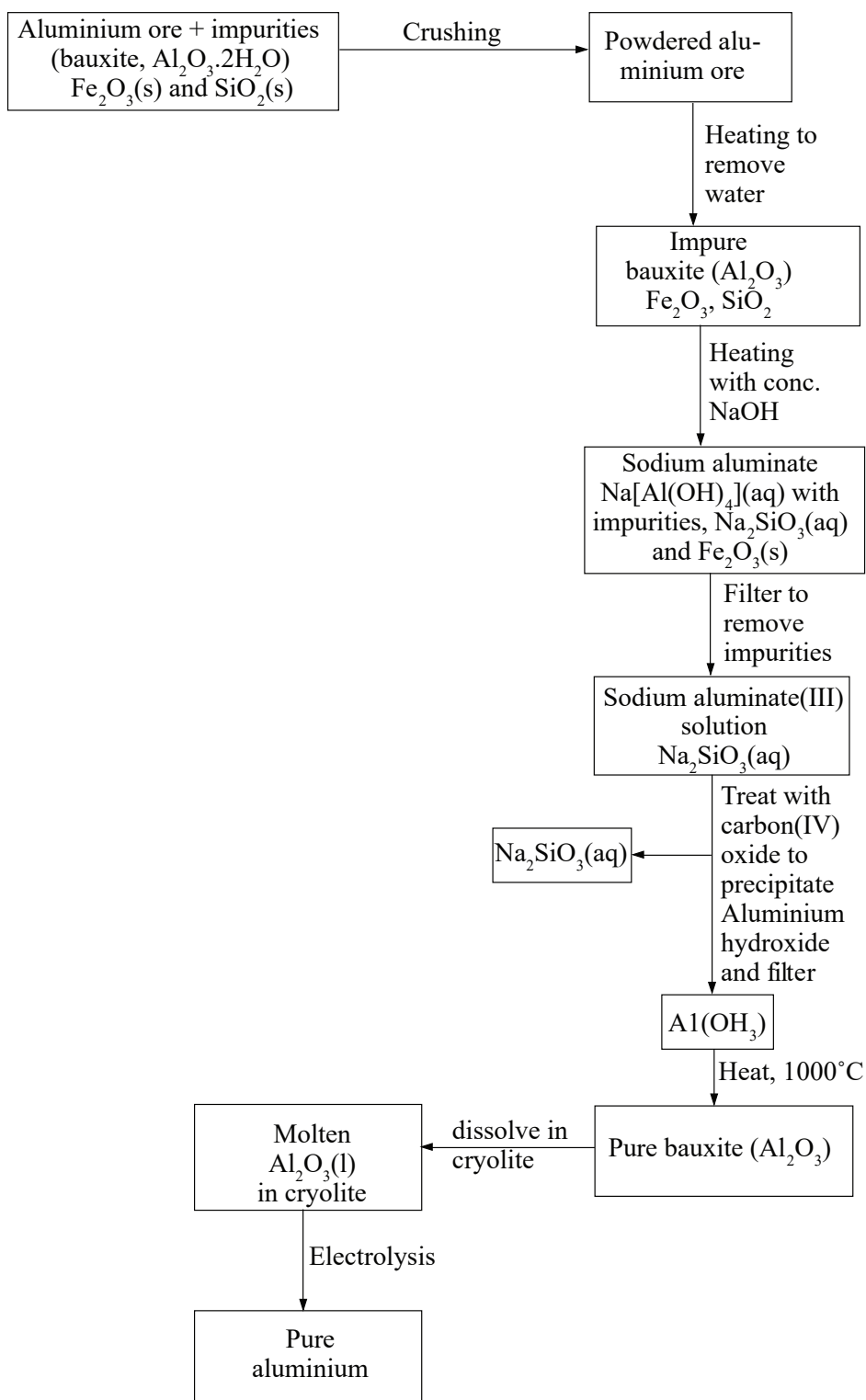

**Fig 4.4: Flowchart summary of extraction of aluminium from Bauxite**

## Uses of aluminium

- (i) In making aeroplane parts, buses, tankers, furniture because aluminium is very light.
- (ii) Making duralumin - because it is an alloy which is harder and has a higher tensile strength.
- (iii) Making utensils, sauce pans, spoons because it is light and good conductor of electricity.
- (iv) Making overhead electric cables because it is light, ductile and good conductor of electricity.
- (iv) Used in the thermite process for production of manganese, chromium and titanium.

## Environmental effects of extracting aluminum from Bauxite

- Carbon dioxide gas that escapes to the atmosphere is a greenhouse gas that causes global warming.
- Bauxite is extracted by open cast mining that causes land degradation.

### Activity 4.1

#### *Test for presence of $Al^{3+}$*

##### **Apparatus**

Test tubes, droppers, boiling tube, test tube rack.

##### **Reagents**

Aluminium compound, 2M sodium hydroxide, 2M aqueous ammonia, sodium sulphate solution, nitric acid.

##### **Procedure**

Grind the ore provided and dissolve it in hot nitric acid in a boiling tube. Filter to remove unreacted ore. Divide the filtrate into 3 portions.

- (i) To the first portion add sodium hydroxide dropwise until in excess.

Observation	Conclusion

- (ii) To the second portion add ammonia solution dropwise until in excess.

Observation	Conclusion

- (iii) To the third portion add three drops of sodium sulphate.

Observation	Conclusion

## Check your progress 4.2

1. An unknown rock X was discovered in Kongor. Test with dilute sulphuric (VI) acid shows rapid effervescence with production of a colourless gas A that forms a white precipitate with lime water and colourless solution B. On adding 3 cm<sup>3</sup> of 2M sodium hydroxide, a white precipitate C is formed that dissolves to form a colourless solution D on adding more sodium hydroxide. On adding 2M aqueous ammonia, a white precipitate E is formed which persists in excess aqueous ammonia, on which on adding 5 cm<sup>3</sup> of 1M lead(II) nitrate(V) to F a white precipitate G is formed which remains on heating.

Identify:

A \_\_\_\_\_

B \_\_\_\_\_

C \_\_\_\_\_

D \_\_\_\_\_

E \_\_\_\_\_

F \_\_\_\_\_

2. (a) Aluminium is obtained from the ore with the formula  $\text{Al}_2\text{O}_3 \cdot 2\text{H}_2\text{O}$ . The ore is first heated and refined to obtain pure aluminium oxide ( $\text{Al}_2\text{O}_3$ ). Describe the process of concentrating of the ore.
- (b) What would be the importance of heating the ore first before refining it?
- (c) The refined ore has to be dissolved in cryolite first before electrolysis. Why is this necessary?
- (d) Why are the carbon anodes replaced every now and then in the cell for electrolysis of aluminium oxide?
- (e) State two uses of aluminium giving reasons why it is suitable for the use.
3. What are some of the environmental effects of extraction of aluminium. Suggest ways of minimizing these effects if any.
4. Electrolysis of bauxite is only possible where electricity is cheap. Do you think there is alternative to this problem? Suggest another method, design how it could be used in extraction of aluminium.

## 4.3 Copper

### Natural occurrence

Copper is found in many different forms. It often occurs in chemical combination with sulphur, iron and oxygen. It is found in large deposits in Zambia, Tanzania, USA and Canada. The chief ores of copper are:

- (i) Copper pyrites ( $\text{CuFeS}_2$ )
- (ii) Malachite ( $\text{CuCO}_3 \cdot \text{Cu(OH)}_2$ )
- (iii) Cuprite ( $\text{Cu}_2\text{O}$ )

### Review corner

A copper is a transition metal. Using your previously acquired knowledge;

1. Explain how you would test for presence of copper metal.
2. Describe some of the characteristics of copper and its compounds.
3. How can you obtain copper metal from its compounds in the laboratory.

## Extraction of copper from copper pyrites

The chief ore for extraction of copper is copper pyrites.

### Concentration of the ore

The ore is first concentrated **by froth floatation** where the copper pyrites is first crushed into fine powder. The powdered ore is then added to water and oil. The purpose of water is to dissolve hydrophilic particles. The purpose of oil is to cover copper ore particles so as to make them hydrophobic.

Compressed air is blown through in the mixture. Creating bubbles that stick around hydrophobic copper ore. The air bubbles, raise through buoyancy, small hydrophobic copper ore coated particles to the surface. A concentrated ore floats at the top as froth.

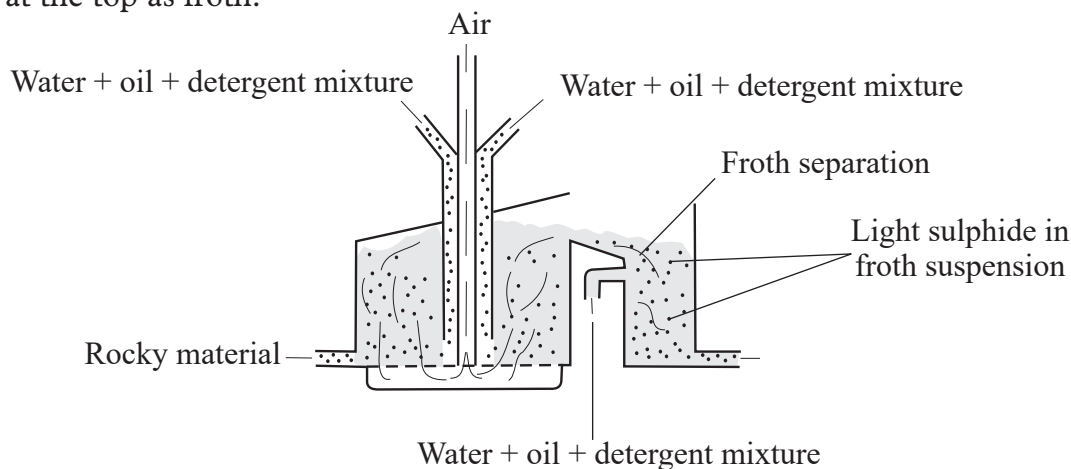
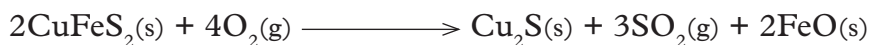

**Fig 4.5: Concentrating copper ore**

The concentrated ore is then skimmed off.

### Reduction of concentrated copper ore

The ore is then roasted in air to form copper(I)sulphide, sulphur(IV)oxide and iron (II) oxide.



Limestone ( $\text{CaCO}_3$ ) and silicon dioxide ( $\text{SiO}_2$ ) are added and the mixture heated in absence of air. Silicon dioxide ( $\text{SiO}_2$ ) reacts with iron (II) oxide to form iron silicate which constitutes the slag and is removed.



The slag separates off from the copper(I)sulphide. Copper(I)sulphide is then heated strongly in a furnace in a regulated supply of air where some of it is converted to copper (I) oxide.

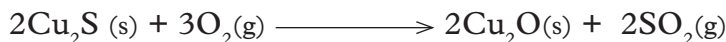

The mixture then undergoes self reduction in which copper(I)oxide is reduced by copper(I)sulphide to copper metal.



The copper obtained still has iron, sulphur and traces of silver and gold as impurities. It is about 97.5% pure. This copper at this stage can only be used for making pipes. For it to be used for electrical wiring it must be refined or purified by electrolysis.

### Refining of copper by electrolysis

During the refining of copper by electrolysis, the impure copper is made the anode and a small pure copper strip is made the cathode.

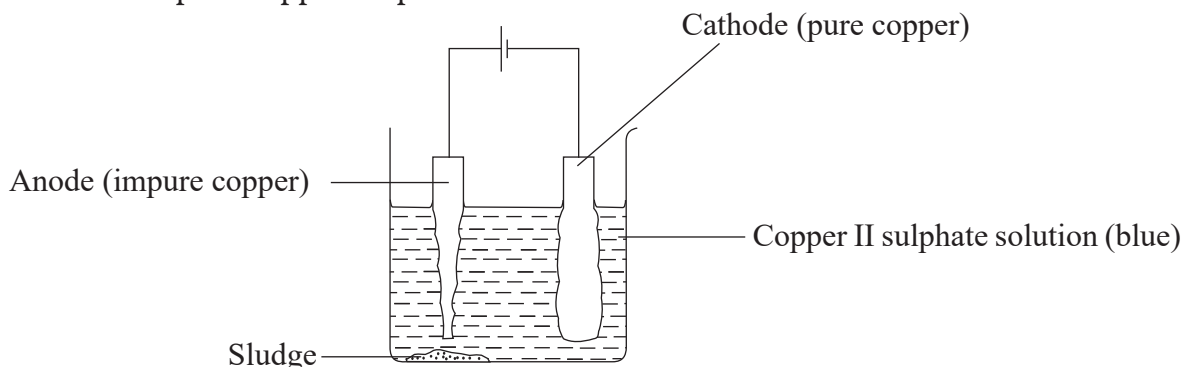

**Fig 4.6: Purification of copper by electrolysis**

The reactions taking place at the electrodes:

#### At the anode

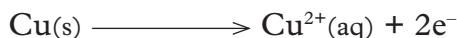

Impure copper anode dissolves into solution to form copper (II) ions. Anode decreases in size. The impurities drop below the electrode.

#### At the cathode



**Note:** The copper (II) ions in the electrolyte ( $\text{CuSO}_4$ ) are reduced (discharged) and get deposited as copper metal at the cathode. The cathode gains mass. The copper obtained is 99.98% pure.



Valuable traces of silver and gold collect at the bottom of the electrolytic cell as sludge. They are used to finance the extraction of copper pyrites.

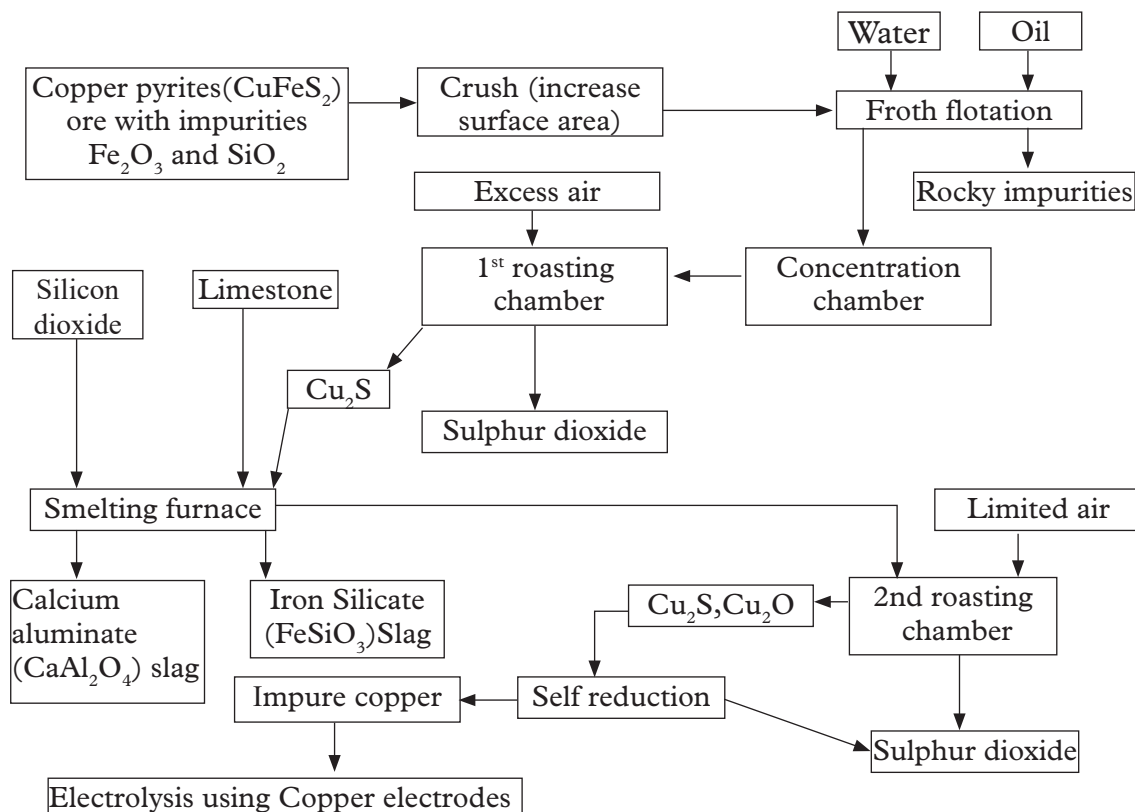

**Fig 4.7 Flowchart showing extraction of copper**

## Uses of copper

Copper is mainly used in:

- (i) Making low voltage electric cables, contact switches, sockets and plugs because it is a good conductor of electricity.
- (ii) Making soldering wires because it is a good thermal conductor.
- (iii) Making useful alloys e.g.
  - Brass is an alloy of copper and zinc (Cu/Zn)
  - Bronze is an alloy of copper and tin (Cu/Sn)
  - German silver is an alloy of copper, zinc and nickel (Cu/Zn/Ni)
- (iv) Making coins and ornaments.

## Environmental effects of extracting copper from copper pyrites

- (i) Sulphur dioxide is a poisonous gas that can cause breathing problems and headaches to humans when breathed in substantial amount.
- (ii) Sulphur dioxide gas if allowed to escape into the atmosphere, dissolves in rain water to form acidic rain i.e. weak sulphuric or sulphurous acid which lowers

the pH of the water bodies causing marine pollution, accelerated roofs or buildings surfaces corrosion and poor crop growth.

(iii) Copper is extracted by open cast mining leading to land degradation.

### Discussion corner!

In groups of three, discuss and suggest ways in which the environmental effects of extraction of copper can be controlled. Make a presentation of your report to the rest of the class

## Activity 4.2

### *Test for the presence of copper in a compound*

#### **Apparatus**

Boiling tube, test tubes, droppers, mortar and pestle, filter paper, filter funnel.

#### **Reagents**

Copper compound, nitric acid, ammonia solution.

#### **Procedure**

1. Grind the ore in a mortar using a pestle. Add the crushed ore in hot nitric acid.
2. Filter to remove unreacted ore. To the filtrate, add ammonia solution dropwise until in excess. Observe and record your observations.

Observation	Conclusion

### The Facts

The ore is ground to increase the surface area. When it is added to the nitric acid,  $\text{Cu}^{2+}$  ions are freed. The ions react with ammonia solution to form a blue precipitate which dissolves in excess ammonia solution to form a **deep blue solution**.

## 4.4 Iron

### Natural occurrence

Iron is the second most abundant common naturally occurring metal. It makes 4% of the earth's crust as:

- (i) Haematite ( $\text{Fe}_2\text{O}_3$ )
- (ii) Magnetite ( $\text{Fe}_3\text{O}_4$ )
- (iii) Siderite ( $\text{FeCO}_3$ )

Iron being a less reactive metal is extracted by reduction using carbon in a blast furnace. A blast furnace is a steel tank lined with bricks on the outside.

### Blast furnace for extraction of iron

The main ore for extraction of iron is **Haematite**. It can also be extracted from magnetite and siderite.

#### Step 1: Preparation of the ore

The ore (haematite) is first crushed after which it is heated. The process of heating removes water and other impurities with low melting. This gives the iron ore about 30 – 95% of the required iron (III) oxide depending on the quantity of the ore. The other remaining impurities are silica ( $\text{SiO}_2$ ) and alumina ( $\text{Al}_2\text{O}_3$ ). In situations where sulphide and carbonate ores are used they should be first converted to the oxide by roasting in air as follows:

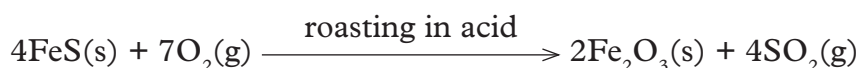

#### Step 2: Reduction of the iron (III) oxide in blast furnace

The raw materials also known as **charge** is fed into the blast furnace from the top. The raw materials include the ore, coke and limestone.

Near the bottom of the furnace, blast of hot air at about  $827^\circ\text{C}$  is forced into the furnace through small holes called **tuyeres**.

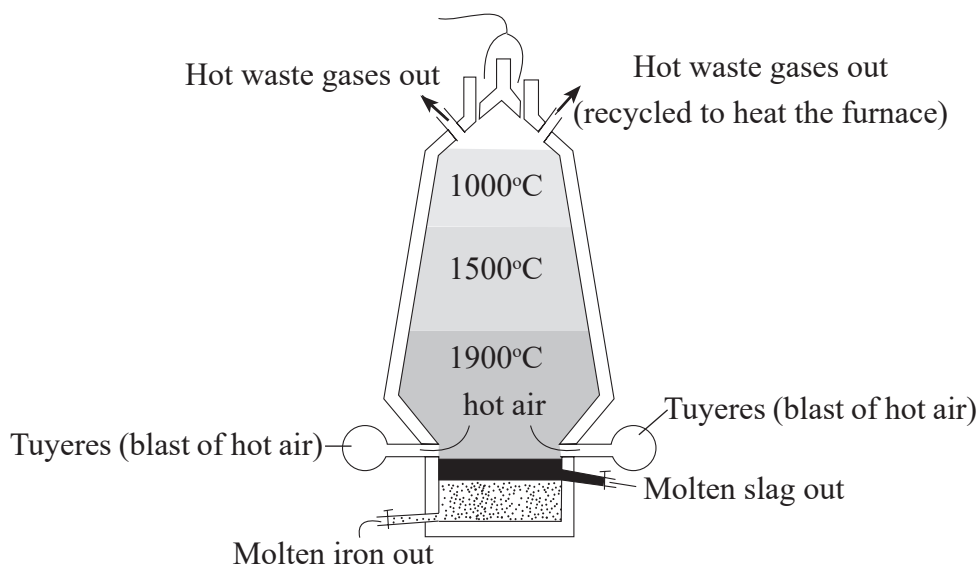
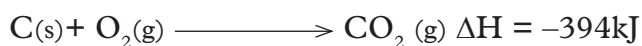

*Fig 4.8: Blast furnace for reduction of iron (III) oxide*

## Chemical processes

Haematite ( $\text{Fe}_2\text{O}_3$ ), magnetite ( $\text{Fe}_3\text{O}_4$ ), coke and limestone are all fed from top into a blast furnace. The furnace is covered with inverted double cap to reduce amount of any gases escaping .

As the air enters, it reacts with coke to form carbon dioxide gas. This reaction is highly exothermic.



This raises the temperature at the bottom of the furnace to about  $1650^\circ\text{C}$ . As carbon dioxide gas rises up the furnace it reacts with more coke to form carbon monoxide gas. This reaction is endothermic therefore leads to a drop in temperature in the upper parts of the furnace.

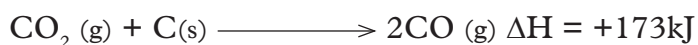

Carbon monoxide gas is a strong reducing agent that reduces the ores at the upper parts of the furnace where temperatures are about  $500^\circ\text{C}$ .

For haematite;

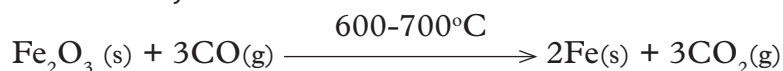

For Magnetite;



Iron is denser than iron ore. As it falls to the hotter base of the furnace it melts and can easily be tapped off.

Limestone fed into the furnace decomposes to calcium oxide and produce more carbon dioxide gas.



Calcium oxide reacts with the impurities silicon dioxide ( $\text{SiO}_2$ ) and aluminium oxide ( $\text{Al}_2\text{O}_3$ ) in the ore to form calcium silicate and calcium aluminate respectively.

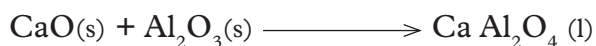

Calcium silicate and calcium aluminate mixture is called **slag**. Slag is denser than iron ore but less dense than iron therefore **floats** on the surface of pure iron. It is tapped off at different level for use in:

- (i) tarmacking of roads
- (ii) cement manufacturing
- (iii) as building construction material.

## Uses of iron

Iron obtained from the blast furnace is hard and brittle. It is called **pig iron**. It contains about 90-95% of iron, containing impurities mainly carbon, sulphur and phosphorous. These impurities the iron brittle limiting its usefulness, for example it can be welded and it has low tensile strength.

Iron is mainly used to make:

- (i) gates, pipes, engine blocks, rails, charcoal iron boxes, lamp posts because it is cheap.
- (ii) constructing nails, cutlery, scissors, sinks, vats, spanners, steel rods, and railway points from steel.

Steel is an alloy of iron with carbon, and vanadium, and or manganese, tungsten, nickel, chromium. It does not corrode like iron.

## Environmental effects of extraction of iron

- (i) Carbon dioxide( $\text{CO}_2$ ) gas is a greenhouse gas that causes global warming if allowed to escape from the furnace.
- (ii) Carbon monoxide( $\text{CO}$ ) gas is a highly poisonous odourless gas that can kill on leakage. It is preferentially absorbed by the haemoglobin in mammals instead of oxygen to form a **stable** compound that does not release haemoglobin in the blood.
- (iii) Haematite ( $\text{Fe}_2\text{O}_3$ ), magnetite( $\text{Fe}_3\text{O}_4$ ) and siderite ( $\text{FeCO}_3$ ) are extracted through open cast mining that cause land degradation.

### *Group Task*

In groups of three,

1. Suggest how the environmental effects of extraction of iron can be controlled.
2. Design a method that can be used to extract iron from its ores. Outline the procedure and processes involved.

### Activity 4.3

#### *To test for the presence of iron in a compound*

##### **Apparatus**

Boiling tube, test tubes, droppers, mortar and pestle, filter paper, filter funnel

##### **Reagents**

Iron compound, nitric acid, ammonia solution.

##### **Procedure**

1. Grind the ore in a mortar using a pestle.
2. Add the crushed ore in hot nitric acid.
3. Filter to remove unreacted residue. To the filtrate, add ammonia solution dropwise until in excess.

Observation	Conclusion

### **The Facts**

When ammonia solution is added to  $\text{Fe}^{2+}$  or  $\text{Fe}^{3+}$ , an insoluble green precipitate is formed in the case of  $\text{Fe}^{2+}$ . For  $\text{Fe}^{3+}$ , an insoluble brown precipitate forms.

Which other reagent can be used in place of ammonia solution?

### **Check your progress 4.3**

1. Suggest the best method for extraction of iron. Justify your choice of the mentioned method.
2. Name the reducing agent in the blast furnace. Use the chemical equations to do so.
3. Why is limestone added as raw material in the extraction of iron? Use equations to explain.

## **4.5 Zinc**

### **Natural occurrence**

Zinc occurs mainly in the forms:

- (i) Calamine - zinc carbonate ( $\text{ZnCO}_3$ )
- (ii) Zinc blende - zinc sulphide ( $\text{ZnS}$ )

## Extraction process of Zinc

Zinc is a less reactive metal and therefore it is extracted by reduction using coke.

### Step 1: Concentration of the ore

This is done to increase the percentage of zinc in the ore. The ore is concentrated by the froth floatation, where the ore is added to a detergent bath followed by agitation of the mixture. The conditions in the bath are controlled to let zinc sulphide float while the impurities sink.

### Step 2: Roasting of the ore

During extraction of zinc, the ore is first roasted in air. If calamine, zinc carbonate, is used it decomposes to zinc oxide and carbon dioxide gas.

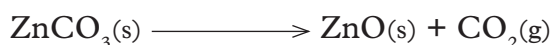

For zinc blende it does not decompose but reacts with air to form zinc oxide and sulphur dioxide gas.

Galena as a useful impurity in the ore also reacts with air to form lead(II) oxide and sulphur dioxide gas.



(Zinc blende)



(Galena)

The oxides are mixed with coke and limestone or iron(II)oxide or aluminium oxide and heated in a blast furnace.

At the furnace temperatures limestone decomposes to calcium oxide and carbon dioxide gas.

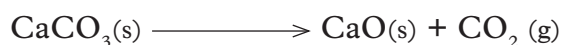

Carbon dioxide gas reacts with more coke to form the carbon monoxide gas.



Both carbon monoxide and coke are reducing agents.

The oxides are reduced to the metals by either coke or carbon monoxide as follows.



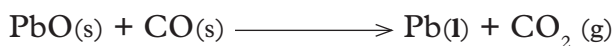

At the furnace temperature:

- (i) Zinc is **vapour** and is collected at the **top** of the furnace. It is condensed in a spray of molten lead to prevent re-oxidation to zinc oxide. On further cooling, zinc collects on the surface from where it can be tapped off.
- (ii) Lead is a liquid and is able to trickle to the bottom of the furnace from where it is tapped off.

Calcium oxide and iron(II)oxide, aluminium oxide are used to remove silica as silicates which float above lead preventing its re-oxidation back to lead(II)oxide.

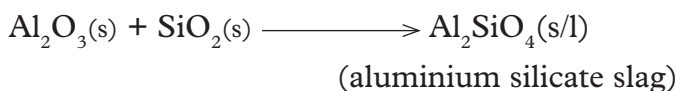
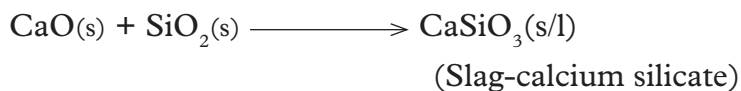

The flow chart below shows extraction of zinc from calamine and zinc blende.

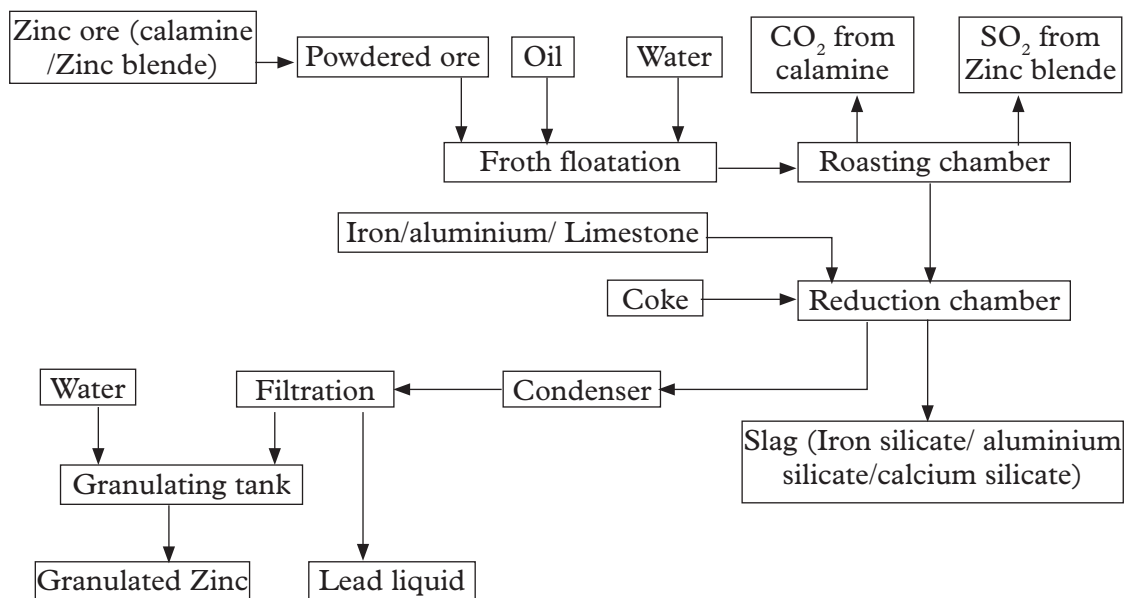

**Fig 4.9: Flow chart on extraction of zinc from calamine, zinc blende**



## Uses of zinc

Zinc is used in:

- (i) Galvanization - when iron sheet is dipped in molten zinc, a thin layer of zinc is formed on the surface. Since zinc is more reactive than iron, it reacts with elements of air ( $\text{CO}_2$  /  $\text{O}_2$  /  $\text{H}_2\text{O}$ ) to form basic zinc carbonate ( $\text{ZnCO}_3 \cdot \text{Zn}(\text{OH})_2$ ). This **sacrificial** method protects iron from corrosion/rusting.
- (ii) As negative terminal and casing in dry/Leclanche cells.
- (iii) Making brass alloy with copper (Cu/Zn).

## Environmental effects of extracting zinc

- (i) Lead impurities and lead salts are predisposing causes of severe cancer.
- (ii) Carbon dioxide is a greenhouse gas that causes global warming.
- (iii) Carbon monoxide is a colourless odourless poisonous gas.
- (iv) Any leakages of sulphur dioxide gas into the atmosphere may cause acid rain, which leads to leaching of soil nutrients and corrosion of buildings surfaces.
- (v) Sulphur dioxide is a poisonous gas that causes irritation to respiratory system in humans if inhaled in substantial concentration.

### Activity 4.4

#### *To test for the presence of zinc*

##### **Apparatus**

Boiling tubes, test tubes, droppers, mortar and pestle, filter paper, filter funnel.

##### **Reagents**

Zinc compound, nitric acid, ammonia solution.

##### **Procedure**

1. Grind the zinc compound in a mortar using a pestle.
2. Add the crushed ore in hot nitric acid.
3. Filter to remove unreacted residues. To the filtrate, add ammonia solution dropwise until in excess.

Observation	Conclusion

### *The Facts*

When few drops of ammonia are added to the filtrate a white precipitate is formed that dissolves in excess ammonia forming a **colourless solution**.

### Group Task

In groups of three, design a method of extraction of zinc. You can make a model showing the various processes or stages of extraction of zinc. Outline the procedure involved. Refer to books as well as internet sources.

## 4.6 Chromium

Chromium is the sixth most abundant transition metal. Chromium is from a greek word *chroma* meaning colour due to many colour characteristics of its compounds.

The ores of chromium include:

- (i) Chromite,  $\text{FeCr}_2\text{O}_4$ , which is the chief ore
- (ii) Crocoite,  $\text{PbCrO}_4$
- (iii) Chrome ochre,  $\text{Cr}_2\text{O}_3$

### Extraction process of chromium

- (a) Ferrochrome is obtained by reduction of chromite using coke in an electric arc furnace. A low-carbon ferrochrome can be produced by using ferrosilicon instead of coke as the reducing agent. This iron/chromium alloy is used directly as an additive to produce chromium-steels which are “stainless” and hard.
- (b) Chromium metal extraction by the reduction of  $\text{Cr}_2\text{O}_3$ . This is obtained by aerial oxidation of chromite in molten alkali to give sodium chromate,  $\text{Na}_2\text{CrO}_4$ , which is leached out with water, precipitated and then reduced to the Cr(III) oxide by carbon. The oxide can be reduced by aluminium (aluminothermic process) or silicon:



### Uses of chromium

Chromium is used to harden steel, to manufacture stainless steel, and to form many useful alloys.

Much is used in plating to produce a hard, beautiful surface and to prevent corrosion. Chromium gives glass an emerald green colour and it is also widely used as a catalyst.

#### Did you know!

Chromium is an essential trace element in mammalian metabolism. In addition to insulin, it is responsible for reducing blood glucose levels, and is used to control certain cases of diabetes.

### Group Task

In pairs, using textbooks and from internet design a method of extraction of chromium from its ore.

Design a planned investigation of the various composition of chromium ores. Share your findings with the rest of the class.

### Project

Research to find out if any of the metals discussed above is formed in South Sudan. If so and within reach, plan a visit to the mining site and learn more about their extraction.

If none is available, design and construct a simple blast furnace used in extraction of iron. What improvement do you think should be made to your structure to improve its effectively.

### Check your progress 4.4

- Give five uses of aluminium.
  - Why is aluminium not extracted by reduction using carbon?
  - Below is a diagram used for electrolysis of aluminium oxide in the extraction of aluminium. Name parts labelled A, B, C, D and E.

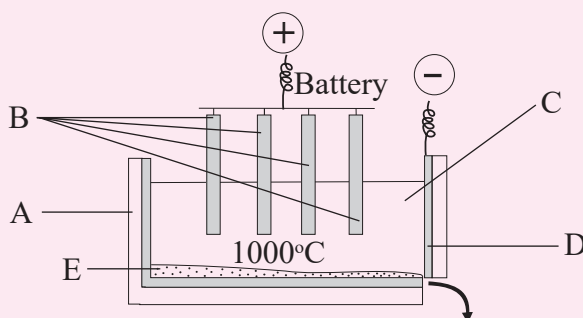

- Write down the reactions that occur at the anode and cathode.
  - What is an amphoteric oxide?
- What makes a substance a waste material in the extraction of metals?
  - Suggest possible ways to control pollution during the extraction of metals.

## 4.7 Properties of metals

### Physical properties of some metals

Study the table below.

*Table 4.1 Physical properties of metals*

Metal	Melting Point(°C)	Boiling Point(°C)	Density g/cm <sup>3</sup>	Thermal Condu-tivity	Electrical Condu-tivity	Malleability	Ductility
Sodium	98	883	0.97	good	good	malleable	ductile
Aluminium	660	2467	2.70	good	good	malleable	ductile
Zinc	420	907	7.14	good	good	malleable	ductile
Iron	1535	2750	7.86	good	good	malleable	ductile
Copper	1085	2572	8.96	good	good	malleable	ductile

What can you conclude about the physical properties of the given metals? Explain your observations.

#### *The Facts*

### Melting and boiling points

Metals generally have high melting and boiling points. This is due to the strong metallic bonds between the fixed positive ions embedded in the 'sea' of delocalised electrons.

However, sodium is an exception with a low melting point of 98°C. This is because of the few delocalised electrons which decrease the strength of the metallic bond. Recall that sodium has a valency of one. So, only one electron is released per atom to the delocalised 'sea' of electrons. The same applies to other metals in group I of the periodic table.

### Density

Metals have high densities because of their structures except sodium and group I metals. The observed different densities in metals is due to different arrangements of atoms in their structures. Again, density increases with increasing atomic number. This is because the mass of an atom increases as the atomic number increases.

### Thermal conductivity

Metals are the best conductors of heat. This is due to the free or delocalised electrons in their structure. When one end of the metal is heated, the heat is felt on the other end when the kinetic energy of the delocalised electrons is increased. This cause them to vibrate, move and hit other nearby electrons resulting in the transfer

of heat. This process will continue until the free electrons transfer the heat to the colder end.

## Electrical conductivity

Electrical conductivity is similar to heat conduction but the electrons move along the wire instead of just vibrating. A flow of electrons in a metal atom pushes the electrons nearest to it so that the entry of one electron pushes out another electron at the opposite end of the metal. This leads to conduction of electrical current.

## Ductility and malleability

- Most metals are **ductile** i.e. they are capable of being drawn out into wires. The atoms within a metal are arranged in layers. Ductility involves slipping of these layers of atoms over each other when the metal is pulled or hit. This results in the formation of wires as shown in Fig. 4.10.

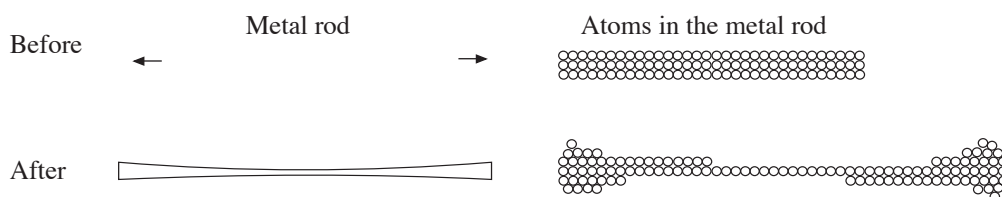

*Fig. 4.10: Ductility in metals*

- Most metals are also **malleable** i.e. they are capable of being hammered into thin sheets. The hammer exerts strong forces on the layers of atoms in the structure of the metal. Because of this property, metals can be bent and moulded into different shapes. This is illustrated in Fig. 4.11 below.

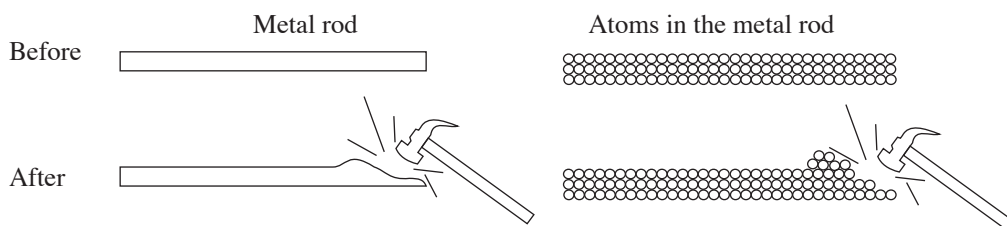

*Fig. 4.11: Malleability in metals*

### Check your progress 4.5

1. Why does sodium have lower melting point compared to other metals?
2. Metals are known to be good conductors of heat and electricity. Explain.
3. Metals are said to be *malleable and ductile*. Explain the meaning of these terms.

## Chemical properties of some metals

### Activity 4.5

*To investigate reaction of metals with substances.*

#### **Apparatus and reagents**

- source of heat
- pair of tongs
- knife
- ceramic tile
- filter paper
- sodium
- aluminium foil
- iron
- copper
- zinc granules
- conc sulphuric acid
- labels
- trough
- Source of chloride gas
- delivery tube
- clamp stand
- deflagrating spoon
- gas jar
- test tubes and racks
- splint
- dilute hydrochloric acid
- source of heat
- conc nitric acid

#### **Procedure**

1. Design experimental procedures using the above provided apparatus and reagents to investigate reaction of metals with:
  - water
  - chlorine gas
  - concentrated nitric and sulphuric acid
  - air
  - dilute hydrochloric acid
2. Present your report in appropriate format.
3. Compare your finding with other groups.

### Check your progress 4.6

1. Aluminium is high in the electrochemical series. Why is it difficult for it to react with air?
2. Given the following metals, sodium, aluminium, iron, zinc and copper.
  - a) Which metals react with steam or cold water?
  - b) Explain your answer in 2 (a) above.
  - c) Write equations for the above reactions.
  - d) What nature of solutions are formed from the above reactions?
3. What observations are made when heated sodium, aluminium, iron, zinc and copper are each inserted to a gas jar of chloride?
4. Why it is not advisable to react sodium with dilute hydrochloric acid in the laboratory?
5. What is observed when
  - a) Zinc is reacted with conc. nitric acid?
  - b) Copper reacts with conc. Sulphuric acid?
  - c) Write chemical equation for the reactions above.

### Learning outcomes

Knowledge and understanding	Skills	Attitudes
<ul style="list-style-type: none"> <li>Describe analytical techniques and methods of determination of structures</li> </ul>	<ul style="list-style-type: none"> <li>Design and carry out investigations and use a range of mediato communicate their work results.</li> </ul>	<ul style="list-style-type: none"> <li>Appreciate the importance of accurate analytical techniques in chemistry</li> </ul>

### Introduction

Have you ever wondered how analytical techniques are used to determine structures? This unit introduces some of these techniques in the analysis and detection of compounds or substances.

There are specialized instruments developed to assist chemists in carrying out these tests. Most organic compounds have specific structures and characteristics unique to themselves which can be precisely analysed and interpreted by special methods and instruments designed for such purposes. Some of the techniques used include:

- Chromatography
- Infrared spectroscopy
- Nuclear magnetic resonance
- Ultraviolet
- Mass spectroscopy



### Activity 5.1

In groups of three, using textbooks and internet,

- (a) Find out the various definitions of analytical chemistry. Which of the definitions do you think is most suitable in context of your study of chemistry of this unit?
- (b) Establish the importance of analytical chemistry identifying its real life applications in your surroundings.
- (c) Having looked at some of the importance of analytical chemistry, identify some of the careers or industries analytical chemists are likely to work in.

### The Facts

One of the definitions of analytical chemistry you might have come across is as follows: analytical chemistry is the science of obtaining, processing, communicating information about the composition and structure of matter (America Chemical Society).

Analytical chemistry studies and uses instruments and methods to separate, identify and quantify matter. Often in practice, the separation, identification or quantification can constitute the entire analysis or sometimes be combined with another method.

For successful analysis in analytical chemistry, thorough knowledge of compositions and structures of compounds is paramount as well use of suitable analytical techniques and instruments in accordance with the standard procedures.

## 5.1 Chromatography

There are various types of chromatography that can be used to analyze the composition of a given sample. They include: **paper chromatography**, **two way chromatography** and **thin layer chromatography** among others.

## Review corner

You learnt about aspects of paper chromatography in Secondary 1. Using the knowledge acquired so far, in groups of two discuss the following questions.

1. Explain the meaning of the following terms,
  - (i) chromatogram
  - (ii) Solvent front
  - (iii) Ascending chromatography
2. Mention three factors that are necessary for the chromatogram to form.
3. Describe how paper chromatography works and some of the applications of chromatography you learnt.

### (a) Paper chromatography

This is analytical technique you studied in Form one as method of separation of mixtures. Chromatography is a technique for separation of components of a solution by passing it through a medium.

Paper chromatography is one of the several types of chromatography. It helps in analysing components of a substance in solution. The method uses a **solvent** and **adsorbent material** – which is usually a high quality filter paper. The solvent is called the **mobile phase** and the water trapped between cellulose fibres of the paper is the **stationary phase**. The analyte is placed on a strip of filter paper and suspended in a solvent such as ethanol then allowed to spread on the adsorbent material.

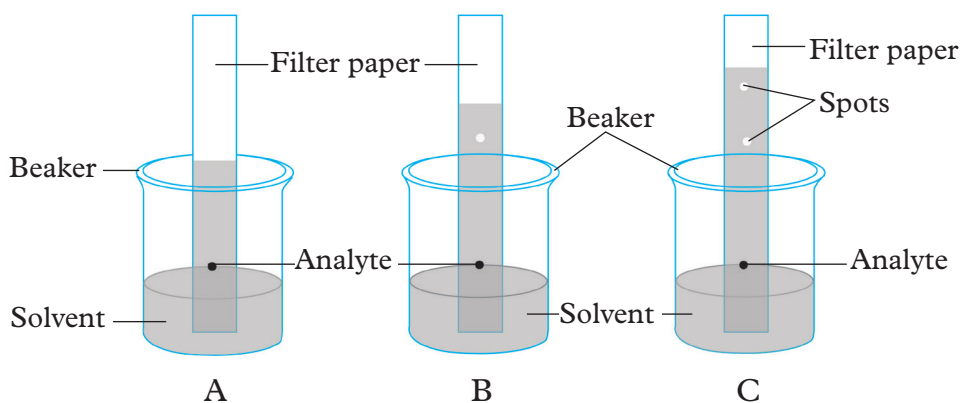

*Fig 5.1: Paper chromatography*

The substances in the mixture will have different solubilities in the solvent and different adsorption rates on the adsorbent material, therefore will move at different rates of flow on the paper. From the chromatogram produced, components of the mixture can be identified by comparison with pure reference compounds or by calculating **retardation factors or relative flow ( $R_f$ )**.

Many different solvents are used in chromatography. Ethanoic acid, ethanol and propanone are examples of organic solvents commonly used since they dissolve many substances which do not dissolve in water.

### Relative flow value ( $R_f$ )

This is the distance travelled by a particular component (spot) in comparison to the distance travelled by the solvent (i.e. solvent front). The ratio of these two distances is called  $R_f$  value.

$$R_f = \frac{\text{Distance moved by the substance}}{\text{Distance moved by the solvent front}}$$

Look at figure 5.2 below. It shows distances moved by pure substance A and pure substance B. Substance A and B in a mixture can be described or identified using their relative flow ( $R_f$ ) value.

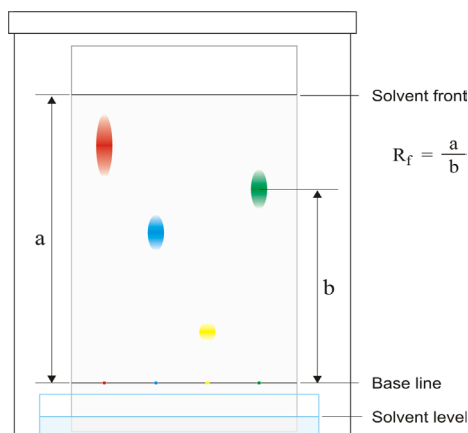

**Fig 5.2: Relative flow**

$R_f$  ranges from 0 to 1.

$R_f$  value of pure A and A in the mixture is always equal. Therefore  $R_f$  can be used to

- identify components of mixture.
- determine if a substance is pure.

A pure substance has only one  $R_f$  value.

The insoluble component (substance) in a solvent remains on the original spot. A substance flows only if it is soluble in the solvent used.

Remember that:  $R_f$  always is compared with the reference values obtained under similar conditions e.g. same temperature and solvent.

### (b) Two-way chromatography

This method of chromatography is used for mixtures in which two or more components have the same  $R_f$  in the same solvent. This means that their spots on paper chromatogram will overlap hence poor separation. In this technique, paper chromatography is run normally but then the chromatogram produced is rotated 90° and re-run in a different solvent. It is unlikely that the  $R_f$  values will coincide in two different solvents so separation takes place.

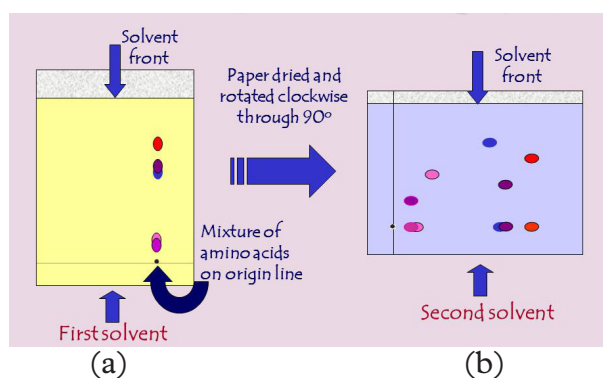

*Fig 5.3: Two-way chromatography*

### Discussion corner!

1. Study Fig 5.3 carefully
  - (i) How many substances can you identify in the mixture(s)
  - (ii) Discuss the similarities and differences between paper chromatography and two way chromatography.
2. Where do you think two-way chromatography is used in our everyday life activities?.

### (c) Thin-layer chromatography

It is used in separation of non volatile mixtures. The process is carried out on solid adsorbent material or layer called the **stationary phase** which is usually aluminium oxide (alumina) or silicon dioxide (silica gel). The solid is spread onto a microscope slide or plate and it is capable of adsorbing solute molecules on its surface. Different analytes move through the plate at different rates making their separation possible.

A chromatogram is then made in a similar way as paper chromatography. That is the sample to be tested is applied on the plate, a solvent or mixture solvent, referred to as mobile phase is then drawn up the plate to help in the separation. Polar molecules have a greater attraction to the polar solid used as stationary

phase, they are adsorbed more strongly into the surface therefore moving slowly up the chromatogram and separation occurs. Solutes are located (visualized) on the chromatogram by applying specialized methods such as projecting ultraviolet light onto the plate or use of chemical processes and the spots identified by comparing with standard known substances or calculating the  $R_f$  values.

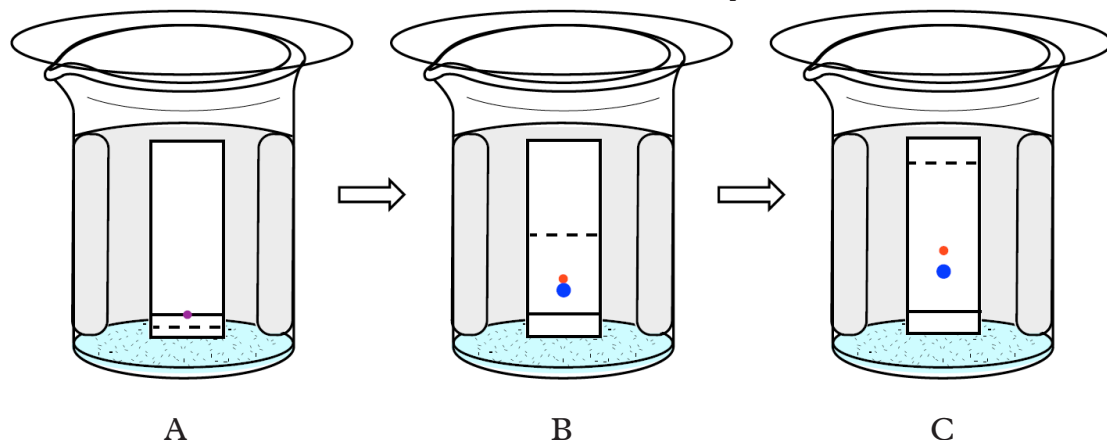

*Fig 5.4: Thin-layer chromatography*

### Identifying the substance using retardation factor values

In determining the substance, the retardation factor is obtained by comparing the distance travelled by the substance and the total distance travelled by the mobile phase. It is important to note that the mobile phase must never be allowed to reach the end of the stationary phase. In principle, a substance with a structure similar to that of the stationary phase will have low  $R_f$  while the one with a similar structure to that of the mobile phase give high retardation factor. For conclusive investigation, because retardation factors are very characteristics in nature, it is recommended that a sample of the compound being investigated be applied to the plate first before running the experiment.

#### Work To Do

Does the stationary phase and mobile phase have same or different properties?  
Give reasons for your answer.

### Advantages of thin layer chromatography

1. It is a short time of analysis.
2. All spots can be visualized.
3. Easily adaptable to most pharmaceuticals.
4. Minimum amount of equipment is needed.

## Activity 5.2

### In groups of four

- Design and carry out an experiment of separation of components of chlorophyll in plant leaves. You can seek assistance from chemistry teacher or laboratory technician as it is necessary.
- Identify the solvent front, separated dyes and original spots.

### Discussion corner!

- Explain some of real life applications of chromatography.
- One such applications is the analysis of proteins and amino acids. Identify the suitable chromatograph method and design an investigation procedure for amino the identification of acids.

### Check your progress 5.1

- A chromatogram of acid enzymes X and Y and three simple sugars are shown below.

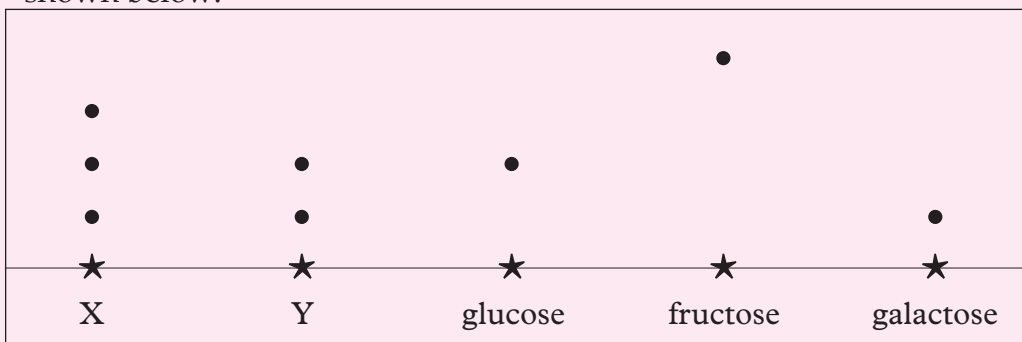

- Draw the solvent front.
  - Which two simple sugars must be present in X and Y?
- A chromatogram of ink from different pens used to sign cheques from three suspects (X, Y and Z) and a genuine one are shown below.

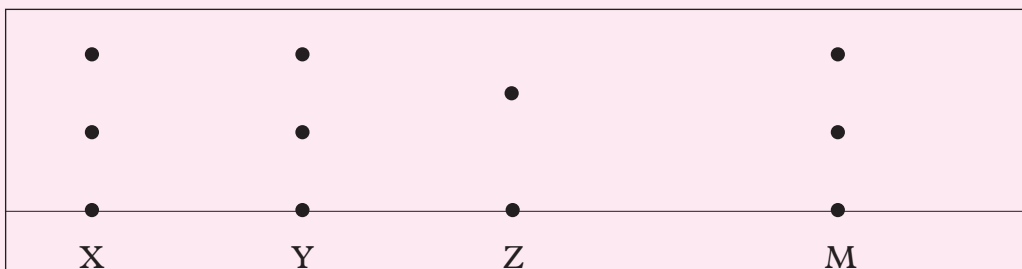

A genuine cheque should be signed using ink M. Which suspect has a forged cheque?

## 5.2 Infrared spectroscopy

### Discussion corner!

You have come across the words “infrared and ultraviolet” in the course of study up to now, many times. In groups of three,

- (i) Describe the terms infrared and ultraviolet and their properties as you learnt in Physics or from your research. Define the word “spectroscopy”.
- (iii) Briefly explain some of uses and dangers associated with ultraviolet lights.

The light our eyes see is but a small part of a broad spectrum of electromagnetic radiation. On the immediate high energy side of the visible spectrum lies the ultraviolet, and on the low energy side is the infrared. The portion of the infrared region most useful for analysis of organic compounds is not immediately adjacent to the visible spectrum. But it has a wavelength range from 2,500 to 16,000 nm, with a corresponding frequency range from  $1.9 \times 10^{13}$  to  $1.2 \times 10^{14}$  Hz.

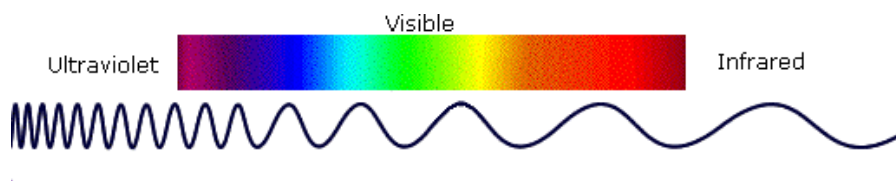

*Fig 5.5: Variation in wavelength in different rays of light*

The infrared spectroscopy helps to identify organic compounds by irradiating the sample being analyzed with electromagnetic waves in the infrared region of the electromagnetic spectrum. The machine used is called **spectrophotometer** and it detects the intensity of the wavelengths of infrared radiation passing through the sample.

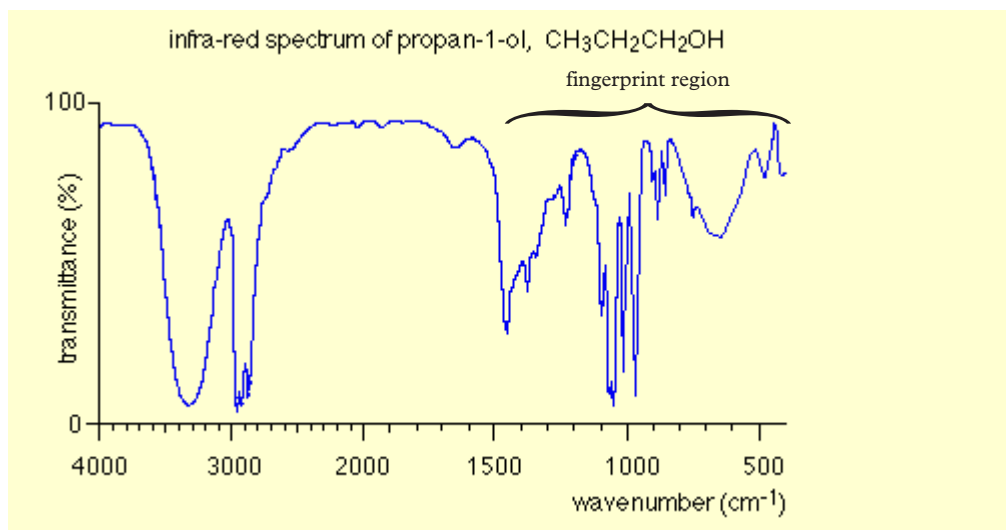

*Fig 5.6: Spectrophotometer*

All organic compounds absorb radiation in the infrared range of wavelength. The energy absorbed corresponds to changes in vibration of the bonds between atoms. Various bonds have a natural frequency wavelengths at which they vibrate. If molecules are irradiated with energy that corresponds to these frequencies, it stimulates large vibrations and energy is absorbed. This is called **resonance frequency** of that vibration.

Each type of vibration will absorb characteristic wavelength of infrared radiation which is expressed as the reciprocal of the wavelength in a unit called **wave numbers** (measured in  $\text{cm}^{-1}$ ). The absorption frequency of a bond is not specific. It varies depending on the other types of molecules bonded to it, therefore it is given as a range.

The presence or absence of different functional groups can be identified from the absorbance pattern on an infrared spectrum. The infrared spectrum has two regions, the one to the right and the one to the left. The one to the right is more complicated and is called the fingerprint region, just like the finger print is used to identify a specific person, this region identifies a specific organic compound with its functional group, for example, i.e it can identify propan-1-ol from propan-2-ol. The left hand side is more simple and will only identify the functional group e.g. OH which has a specific range of absorbance.



*Fig 5.7 (a): Infrared spectrum of propanol-1-ol*



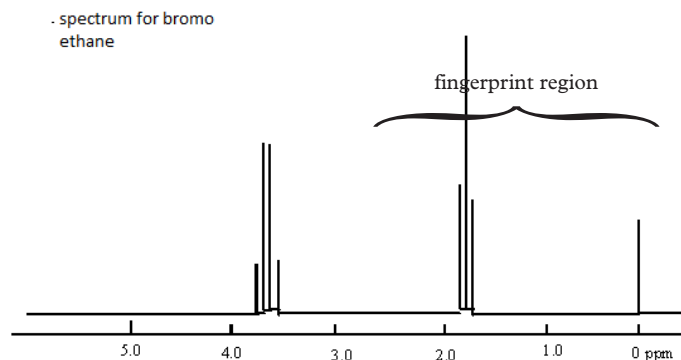

**Fig 5.7 (b): Infrared spectrum of propanol-2-ol**

Both have similar spectra in the region of 3000 wave numbers because they have the same functional group OH, but in the region of 1500 to 500  $\text{cm}^{-1}$  the regions are different because of position of attachment of -OH group.

### Applications of infrared spectroscopy

Infrared spectroscopy has important uses in industry as well as in research. It is a very reliable scientific technique for measurement, quality check and dynamic measurement. It is also widely used in forensic analysis in civil and criminal investigations.

Some of the major applications of infrared (IR) spectroscopy are as follows:

#### 1. Identification of functional group and structure elucidation

As we have seen from the above graphs, the peaks corresponding to different functional groups can be observed. According to corresponding peaks, the functional group can be easily determined.

Each atom of the molecule is connected by bond and each bond requires different IR region so characteristic peaks are observed. This region of IR spectrum is called **finger print region** of the molecule. It is determined by characteristic peaks.

#### 2. Identification of substances

IR spectroscopy is used to establish whether a given sample of an organic substance is identical with another or not. This is because large number of absorption bands is observed in the IR spectra of organic molecules and the probability that any two compounds will produce identical spectra is almost zero. So if two compounds have identical IR spectra then both of them must be samples of the same substances.

### 3. *Studying the progress of the reaction*

Progress of chemical reaction can be determined by examining the small portion of the reaction mixture withdrawn from time to time. The rate of disappearance of a characteristic absorption band of the reactant group and/or the rate of appearance of the characteristic absorption band of the product group due to formation of product is observed.

### 4. *Detection of impurities*

IR spectrum of the test sample is compared with that of the standard compound. Observation of any additional peaks in the IR spectrum, can be then attributed to impurities present in the compound.

### 5. *Quantitative analysis*

The quantity of the substance can be determined either in pure form or as a mixture of two or more compounds. In this, characteristic peak corresponding to the drug substance is chosen and log pattern of the peaks for standard and test sample is compared. This helps in determining the quantity of the substance.

#### Check your progress 5.2

1. Define infrared spectroscopy.
2. What is the fingerprint region in the infrared spectrum? Explain the term infrared spectrum.
3. How does infrared spectroscopy help in identification of compounds?
4. Mention life application areas where infrared spectroscopy is used.

## 5.3 Nuclear magnetic resonance

#### Discussion corner!

You might have come across or heard of such terms as: nuclear energy, nuclear weapons and atomic nucleus. In groups of three;

- (i) Briefly explain what is nuclear energy.
- (ii) The composition of atomic nucleus and nuclear weapons.
- (iii) Mention dangers of nuclear weapons in your judgement, should these weapons continue to be manufactured in today's world.
- (iv) Explain what is magnetic resonance.

Compile your group report and present it to the class.

Nuclear magnetic resonance (NMR) is based on the fact that many nuclei have spin and all of them are electrically charged. If they are placed in an external magnetic field the nuclei become oriented in a predictable number of orientations (spins) as energy transfer is possible between its base energy to a higher energy level. The energy transfer takes place at a wavelength that corresponds to radii frequencies and when the spin returns to its base level, energy is emitted at the same frequency. The signal that matches this transfer is measured in many ways and processed in order to yield an NMR spectrum for the nucleus concerned. There are two major types of nuclear magnetic resonance.

There are two types of orientations when external magnetic field is applied; alpha and beta orientations. The alpha orientation is more stable because in this orientation the nuclei are aligned with the magnetic field while in the beta state they are aligned against the magnetic field. During interaction with the external magnetic field, energy in the form of electromagnetic radiation converts the excess alpha oriented nuclei into beta state. When the energy is removed, the nuclei relax back to alpha state.

The fluctuation of magnetic field associated with relaxation process is called **resonance**. This resonance is detected and converted into peaks that are seen in an NMR spectra. When the excited nuclei in beta orientation start to relax back into alpha orientation, a fluctuating magnetic field is created which generates a current in the receiver coil around the sample, which is electronically converted in to a peak. The relaxation is the one that gives the peak but not excitation.

Peaks are seen at different positions because nuclei that are not in identical structural positions do not experience the same external magnetic field because the nuclei could be shielded or not shielded.

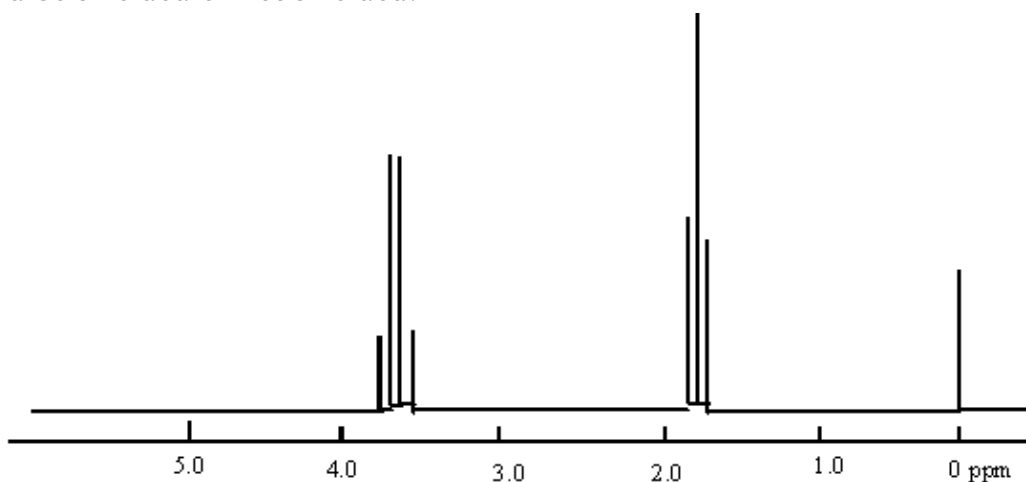

*Fig 5.8: Bromoethane spectrum*

Figure 5.8 shows a spectrum from bromoethane. In the spectrum for  $\text{CH}_3\text{CH}_2\text{Br}$  the hydrogen near the electronegative atom require higher frequency to flip from alpha orientation to beta, so they appear at a higher ppm on the spectrum. The number of peaks is given by the rule  $n + 1$  where  $n$  refers to the number of hydrogen in the neighbourhood. For example, the peaks for hydrogen's attached to the carbon with bromine are four because the carbon in the neighbourhood has three hydrogens hence the ppm  $3 + 1 = 4$ .

### *Research work and Field visit*

1. Have you heard of MRI scan diagnostic machine used by patients sometimes to identify certain medical conditions not easily detected by ordinary diagnostic methods? Using books and internet briefly explain how this process takes place.
2. Plan a visit to a hospital with MRI diagnostic machine and find out how it works.
3. Discuss two types of nuclear magnetic resource.

### **Uses of nuclear magnetic resonance**

1. Chemists use it to determine the molecular identity, purity and structures of compounds.
2. Medical practitioners have embraced this technology for medical diagnostic purposes. It is heavily used for imaging soft tissues of the body such as brain, heart and muscles as well as detection of tumours in many organs of the body.

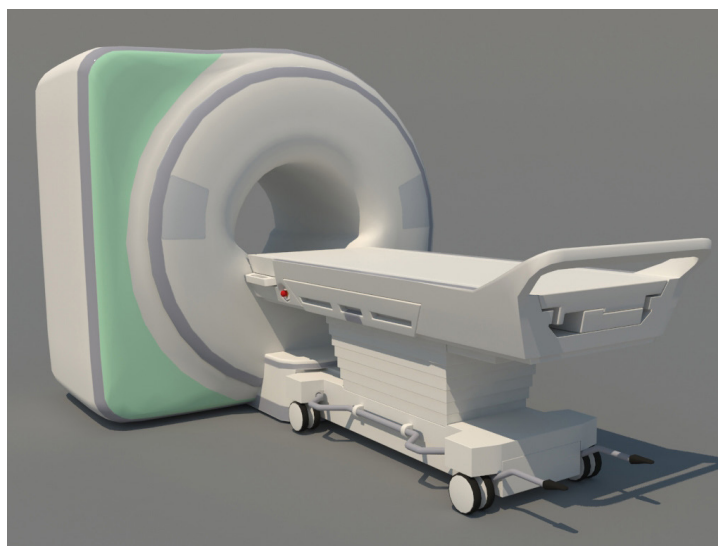

*Fig 5.9: MRI scanner machine*

### Check your progress 5.3

1. Define the following:
  - (i) nucleus spin
  - (ii) nuclear magnetic resonance
2. Briefly explain how nuclear magnetic resonance is used in determining structures of compounds.
3. Why is the external supply of magnetic energy/field and its strength is important in nuclear magnetic resonance diagnostic process?

## 5.4 Ultra violet spectroscopy

This method uses an instrument known as **spectrophotometer**. In this method of analysis a monochromatic source of light mostly in the range of ultra violet is fed into the analyte. Some of the analyte molecules absorb part of the radiations to get into the excited state. The detector attached to the instrument is able to calculate the frequency of the reference radiation and that of the transmitted radiation and hence able to give what has been absorbed which is normally called **absorbance**. A chromatogram of absorbance against wavelength is normally given as a print out by the computer attached to the detector.

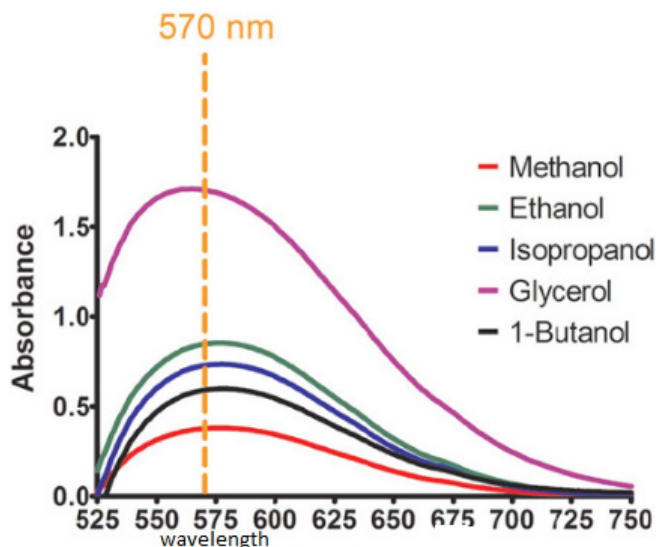

*Fig 5.10: Graph of absorbance against wavelength for various molecules*

The absorbance is affected by:

- concentration
- the solvent used

- the chemical environment of the analyte
- the structural formula of the analyte.

In the chromatogram shown in Fig 5.10, if the solvent and concentration are kept constant then the presence of the  $-OH$  group varies in absorbance because of its chemical environment and the structural formula of the alcohol.

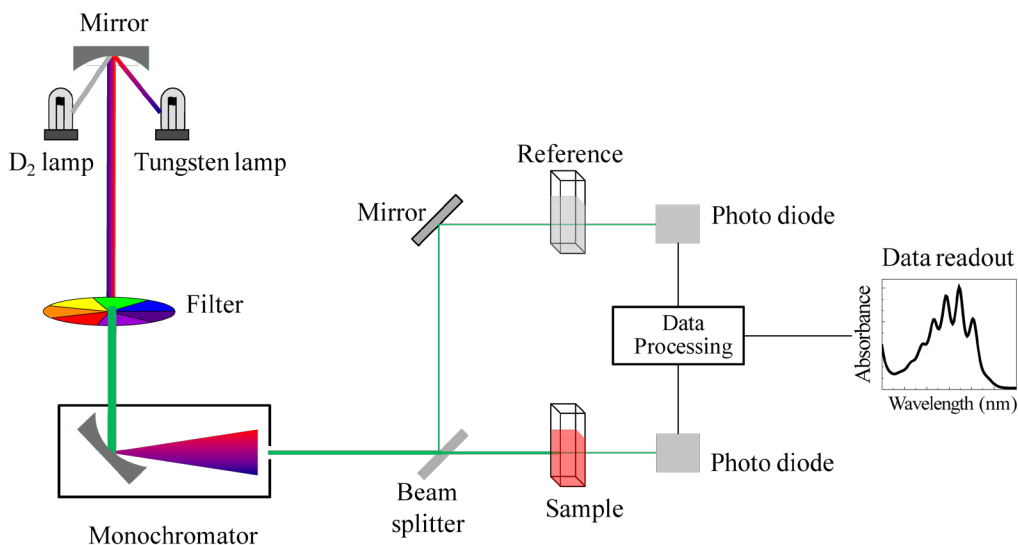

**Fig 5.11: Instrumentation of UV spectrophotometer**

The instrument is able to pick both the reference ultra violet and the ultra violet radiated through the analyte. The detector is therefore able to show the variation in the transmitted signal with that of reference signal and hence able to produce a chromatogram of absorbance against wavelength as shown above.

### Application of visible UV spectroscopy

UV visible spectroscopy is normally used in analytical chemistry for the quantitative determination of different analytes, such as transition metal ions, highly conjugated organic compounds and biological macromolecules.

## 5.5 Mass spectroscopy

**Mass spectrometry (MS)** is an analytical technique that ionizes chemical species and sorts the ions based on their mass-to-charge ratio.

In mass spectroscopy procedure, a sample, which may be solid, liquid, or gas, is ionized, for example by bombarding it with electrons. This may cause some of the sample's molecules to break into charged fragments. These ions are then separated according to their mass-to-charge ratio. They are then accelerated by a constant force.

The charged ions will move at different speed and arrive at the detector at different times. They are therefore detected at different times and the detector gives the spectrum of abundance against charge ratio. Alternatively the fragments are subjected to the same strength of electric or magnetic field and the detector utilizes the extend of deflection to distinguish them.

Results are displayed as spectra of the relative abundance of detected ions as a function of the mass-to-charge ratio. The atoms or molecules in the sample can be identified by correlating known masses to the identified masses or through a characteristic fragmentation pattern.

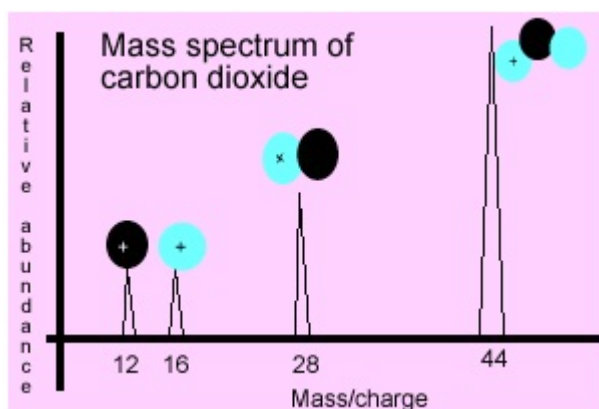

*Fig 5.12: Mass spectrum of carbon dioxide*

The carbon dioxide is fragmented and given a charge.  $\text{CO}_2^+$  has its peak at 44 (equal to its mass) while  $\text{CO}^+$  has its peak at 28 (equal to its mass),  $\text{O}^+$  has a peak of 16 (equal to its mass) and  $\text{C}^+$  is given a peak of 12 (equal to its mass).

### Structures of some compounds

We learnt that each compound has specific and unique structures and compositions. The following are a few examples of structures of common compounds.

(a) Methane

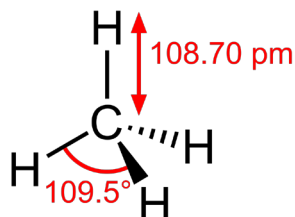

(b) Carbon dioxide

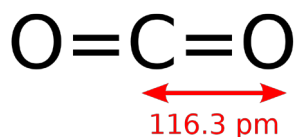

(c) Sodium chloride

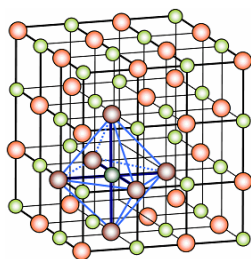

(d) Glucose

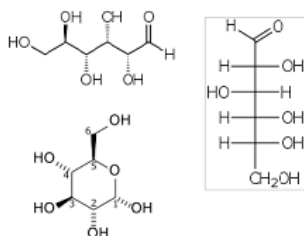

### Check your progress 5.4

1. Distinguish between infrared spectroscopy and MRI.
2. What method would you use to identify the structure of unknown compounds?
3. A mass spectrometer is an instrument used to measure mass to charge ratios of substances. Describe its working principle.



## Learning outcomes

Knowledge and understanding	Skills	Attitudes
<ul style="list-style-type: none"> <li>Understand organic chemistry, including isomerism, fractional distillation and cracking of alkanes, chloroalkanes, alkenes, alcohols, carbonyl group compounds, aromatic chemistry, amines, amino acids, polymers synthesis and analysis.</li> </ul>	<ul style="list-style-type: none"> <li>Explore ways of assessing the impacts of the use of synthetic materials and the environmental issues related to the use of plastics.</li> </ul>	<ul style="list-style-type: none"> <li>Appreciate the importance of organic chemistry to the world's economy.</li> </ul>

## Introduction

Study the following photographs below.



A



B



C



D

Discuss with your friends how the items or substance in use in the photographs above are made. You are now familiar with the term organic and inorganic e.g. organic wastes and inorganic wastes. Describe briefly the meaning of organic substances.

### The Facts

Organic compounds are substances made up of carbon and hydrogen only. They are therefore called hydrocarbons. **Hydrocarbons** are classified into three groups depending on the type of bond that exists between them. The groups are, **alkanes**, **alkenes** and **alkynes**.

Alkanes occur naturally in **fossil fuels**. These include crude oil (petroleum), natural gas and coal. Natural gas found under the sea and in crude oil deposits consist of mainly methane.

Fossil fuels come from plants and animals that died and were buried millions of years ago. Due to high pressure and temperature, these changed their form resulting in the formation of the fossil fuels. These fuels are non-renewable (once they are used, they are not replaced).

Another natural source of methane is **biogas**. Biogas is formed when microorganisms feed on waste organic products such as animal dung and cellulose in the absence of oxygen resulting in decay. Biogas consists of about (60 – 70) % methane.

**Crude oil** is the major natural source of organic compounds (alkanes). It normally consists of a range of alkanes. These are separated into various compounds by **fractional distillation**. It is possible to separate components of crude oil since they have different boiling points

### Activity 6.1

1. In groups of three, using the internet and textbooks, find out what are organic compounds. Give some of their characteristics.
2. Find out the organic compounds commonly used in your locality. What are the merits and demerits of these organic compounds?

### The Facts

**Organic chemistry** is the branch of chemistry that studies carbon compounds present in living things, once living things or synthetic (man-made).

Compounds that make up living things whether alive or dead largely contain carbon. Carbon forms characteristic stable covalent bonds with itself and with

many other non-metals like hydrogen, nitrogen, oxygen and halogens to form a variety of compounds. This is because:

- (i) carbon uses all the four valence electrons to form four strong covalent bonds.
- (ii) carbon can covalently bond to form a single or double bonds between itself.
- (iii) carbon atoms can covalently bond to form a very long chain or ring.

When carbon covalently bonds with hydrogen only, it forms a group of organic compounds called **hydrocarbons**.

## 6.1 Hydrocarbons

Hydrocarbons are a group of organic compounds containing hydrogen and carbon atoms only.

Depending on the type of bond that exists between the individual carbon atoms, hydrocarbons are classified into:

- (i) Alkanes
- (ii) Alkenes
- (iii) Alkynes

### General uses of hydrocarbons

- Many of the natural fuel sources we use are hydrocarbons. Compounds like methane, butane, propane, and hexane are all hydrocarbons.
- Many of the plastics we use in everyday life and in industry are made from long chains of monomers, formed from petrochemicals. These petrochemicals are simply hydrocarbons of different chemical compositions.
- The wax that we use for a variety of industries, everything from candle making and food preservation to medical and industrial uses, contains hydrocarbons.
- Some common medical drugs we use contain a hydrocarbon.

## 6.2 Alkanes

### Activity 6.2

1. In groups of three, list examples of alkanes that are commonly used in our daily lives.
2. Alkanes are named based on the number of carbon atoms they possess in their structure, for example the prefix **meth** stands for 1, find out the prefixes for the rest of carbon atoms up to six.

## Naming of alkanes

Alkanes are hydrocarbons with a general formula  $C_nH_{2n+2}$  where  $n$  is the number of carbon atoms in that molecule. In the bonding of these hydrocarbons, the carbon atoms are linked by single bond to each other and to the hydrogen atoms. In the naming of the alkanes, we use a prefix and a suffix. The prefix depicts the number of carbon atoms in their structure, while the suffix depicts their series.

Table 6.1: Examples of alkanes

n	Prefix	Suffix	Name	General formula
1	meth	ane	methane	$CH_4$
2	eth	ane	_____	$C_2H_6$
3	prop	ane	_____	$C_3H_8$
4	but	ane	_____	_____
5	pent	ane	_____	_____
6	hex	ane	_____	_____
7	hept	ane	_____	_____

### Activity 6.3

1. Discuss with your deskmate about examples of alkanes of table 6.1 above.
2. Looking at the trends in molecular formular, what biggest discovery do you make?
3. Complete table 6.1 above.

The alkane members in the above series differ by a  $-CH_2-$  unit. They form a common series that show similarity in chemical reactions, and a trend in their physical properties. Such a series is called a **homologous series**. Alkanes therefore make up a homologous series.

There are different ways of writing the formula of alkanes and hydrocarbons in general. The first method is the one shown above  $C_nH_{2n+2}$ , that is called **general formula**;

The other way of writing the formula is called **structural formula**.

Structural formula of some alkanes,

(i) Ethane

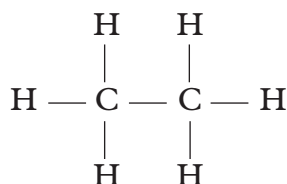

(ii) Butane

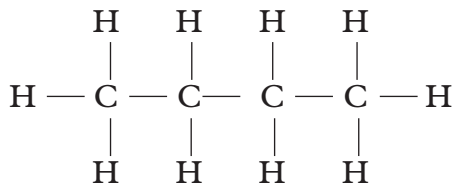

## Activity 6.4

1. In both methods, observe the number of carbon atoms and hydrogen atoms. From your observation, what do you think is the main difference between the molecular formula and the structural formula?
2. For the uncompleted alkane members in the table 6.1, draw both their molecular and structural formula for each. Compare your answers with your deskmate's work.
3. Another way of writing the formula of hydrocarbon is by use of condensed formula. Research and practise writing the condensed formula for the first six alkanes.

### The Facts

The **molecular formula** simply shows the number of atoms of each element in a compound while the **structural formula** shows how the elements in a particular compound are actually arranged.

### Remember!

Carbon is tetravalent element, so carbon forms a maximum of four covalent bonds.

Hydrogen is monovalent, each atom of hydrogen in the alkane must always be bonded using one covalent bond.

## Isomers of alkanes

**Isomers** are compounds with the same molecular formula but different structural formulae. It is like the isotopes of elements.

Isomerism is the existence of compounds having the same molecular formula but different structural formulae.

For example,  $\text{CH}_3\text{CH}_2\text{CH}(\text{CH}_3)\text{CH}_3$  and  $\text{CH}_3\text{C}(\text{CH}_3)_2\text{CH}_3$

Above compounds conform to the molecular formula  $\text{C}_5\text{H}_{10}$  but have different structural formulae. They are called isomers.

Think of the other isomers. Name and draw their structural formulae.

Isomers are named using the IUPAC (International Union of Pure and Applied Chemistry) system of **nomenclature**.

The IUPAC system of nomenclature follows basic rules:

- Identify the longest continuous carbon chain, which is used in determining the parent alkane.
- Identify the substituent groups. These are molecules that are not part of the chain and appear as branched groups.
- Number the longest chain starting from the end of the chain that is near the branched groups. The branched group is to get the lowest possible number.
- Determine the position and type of branched group i.e. identifying them as methyl, ethyl, propyl e.t.c. according to the number of carbon attached.
- Use prefix di-, tri-, tetra to show the number of branched groups attached to the parent alkane.

## Writing the molecular formula, drawing the structural formula and naming of alkanes

(i) 2 – Methylbutane,  $\text{CH}_3\text{CH}(\text{CH}_3)\text{CH}_2\text{CH}_3$

### Procedure

1. Identify the longest continuous carbon chain to get/determine the parent alkane. In this case;

Butane is the parent name:  $\text{CH}_3\text{CH}_2\text{CH}_2\text{CH}_3$

2. Number the longest chain from the end of the chain that is near the branching group so that the branch gets the lowest number possible, i.e.,

The methyl group should be attached to Carbon “2”

3. Determine the position, number and type of branched group. Name it or them accordingly such as methyl, ethyl etc. according to the number of carbon chains in the branched group. That is;

Position of the branching is at carbon “2”

Number of branching at the parent alkane is “1”

Type of the branching “methyl”

Therefore;

*Molecular formula*

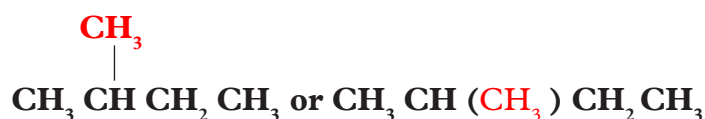

**Structural formula**

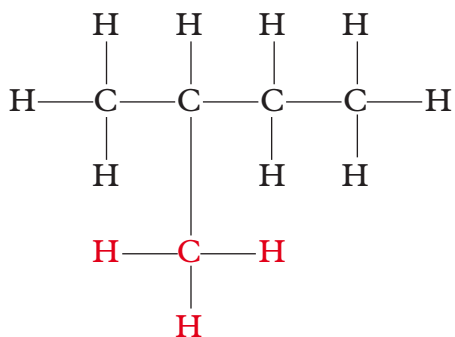

2-methylbutane

**(ii) 2,2-dimethylpentane**

Molecular formula

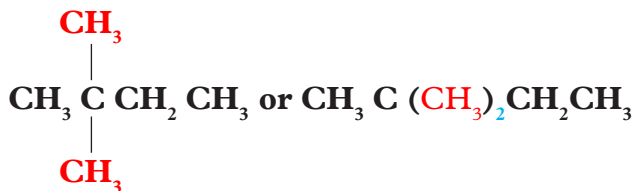

**Structural formula**

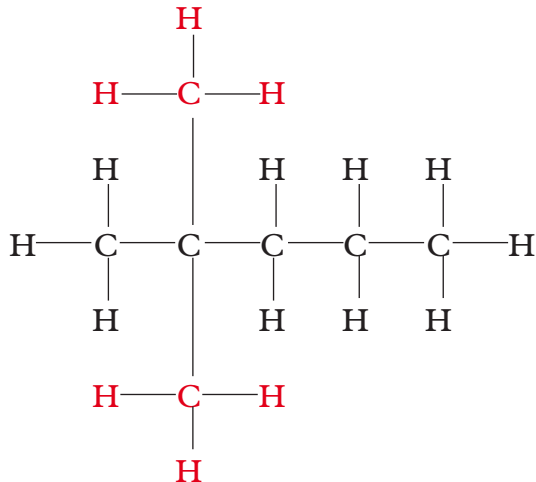

**Group Task**

In pairs, discuss the various aspects of the naming of the above hydrocarbon compounds.

- What do the numbers; 2, 2 represent in the naming of 2, 2-dimethyl pentane?
- Why is the prefix “di-” used in the naming?

## Occurrence and extraction of alkanes

### Review corner

You have learnt about fractional distillation of air in previous classes. Using the acquired knowledge so far;

- Define the term fractional distillation. Briefly describe how it is used in the separation of components of atmospheric air.
- In your own opinion and judgement how do you think this method applies in the extraction of various alkanes.

### Fractionating column

Crude oil, natural gas and biogas are the main sources of alkanes. Natural gas is found on top of crude oil deposits and consists mainly of methane.

The separation of the different alkanes from crude oil is made possible through **fractional distillation**, a process often called refining the crude oil. The distillation takes place in a tall tower called **fractional tower** or **column** where the oil is heated to relatively high temperatures. The hydrocarbon with smaller number of carbon atoms in the chain having lower boiling point is first separated.

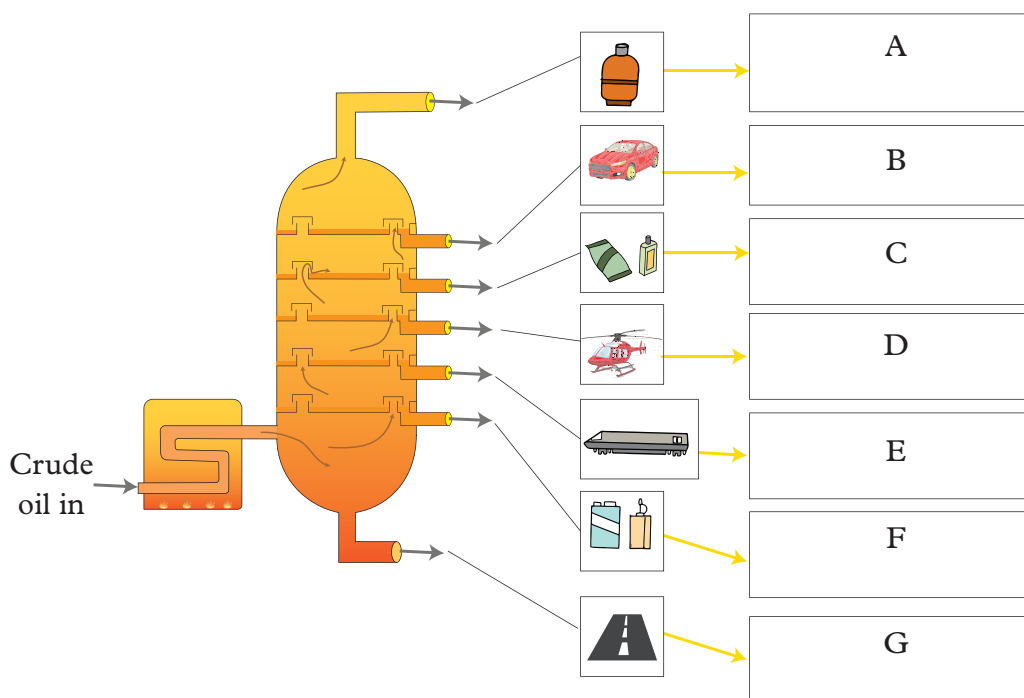

*Fig 6.1: Fractionating column for separation of various alkanes from crude oil*



The carbon chain increases as we move down. As the carbon chain increases, the boiling point, viscosity (ease of flow) and colour intensity increases as flammability decreases.

### Work to Do

1. Identify fractions A – G
2. The fractions above have no sharp melting point and boiling points. Explain.
3. For each fraction enlisted above state their uses.
4. Why do the demand for long chain alkanes is not as intense as the demand for short chain alkanes?

## Cracking of alkanes

This is the breaking of the long chain alkanes into those of smaller molecules. When this happens, alkenes and sometimes hydrogen gas is produced. The process is carried out at elevated temperatures using a catalyst. Aluminium oxide or silica are used as catalysts. For example,



There is a higher demand for shorter chain alkanes than long chain alkanes. Shorter chain alkanes are used more frequently than longer chain alkanes and therefore the need for cracking.

## Preparation and properties of methane and ethane

### Activity 6.5

Laboratory preparation of methane.

#### *Apparatus and chemicals*

- hard glass test tube/ round bottomed flask
- source of heat
- delivery tube
- trough
- beehive shelf
- mortar and pestle
- gas jar
- sodium ethanoate
- soda lime (a mixture of sodium hydroxide and calcium oxide). It is easier to handle soda lime than the deliquescent sodium hydroxide. It does not dissolve easily.

### Procedure

1. Place about 4-5g of sodium ethanoate and an equal amount of soda lime in a mortar and grind well with a pestle.
3. Transfer the mixture into a hard glass test tube.
4. Set up apparatus as in Fig. 6.2
5. Heat the test tube carefully. Make sure that the water is not sucked back by removing the delivery tube from water immediately after heating is stopped.

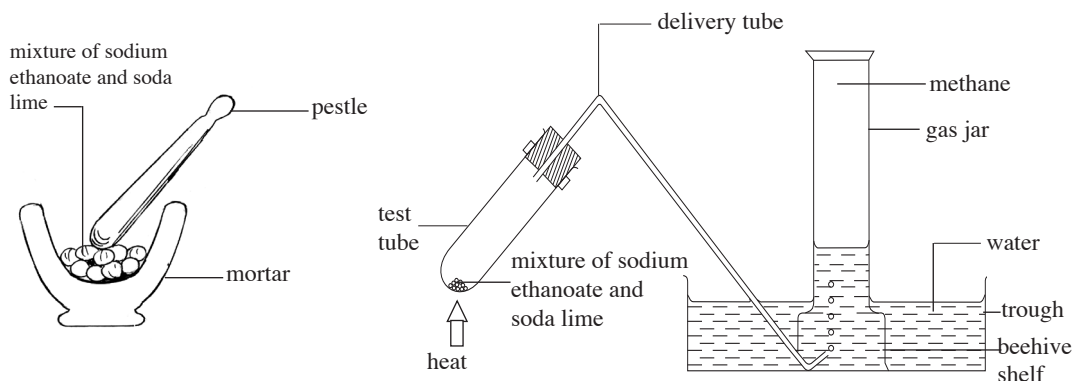

**Fig.6.2: Preparation of methane**

- What do you observe?
  - What is the smell of the gas collected?
  - What physical property of the gas is tested by the method of collection used?
  - What can you conclude from your observations?
  - Record your observations and conclusions in your notebook.
6. Collect three test tubes full of this gas for carrying out the tests shown in Table 6.2. Copy Table 6.2 and record your observations in the spaces provided.

**Table 6.2: Observations on chemical reactions of methane**

Test-tube	Test	Observations
1	Introduce a lighted splint at the mouth of the test tube containing the gas	
2	Invert a test tube full of methane in a beaker containing methylbenzene	
3	Add about 4-5 drops of bromine water	

- What do you conclude about methane?
- Write equations for reactions that take place.

## The Facts

Methane is prepared in the laboratory by heating a mixture of sodium ethanoate and soda lime. The sodium hydroxide in the mixture reacts with sodium ethanoate to form methane gas and sodium carbonate. The equation for the reaction is:

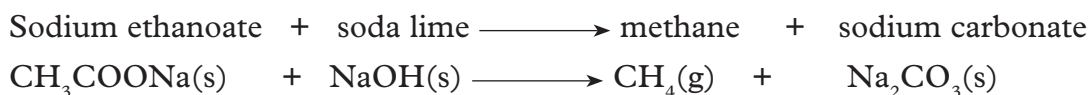

Generally any alkane can be prepared by similar reactions represented by the following equation:



where  $n = \text{a whole number } 1, 2, 3, \dots$

## Physical properties of methane

Methane:

- is a colourless gas.
- is an odourless gas.
- is less dense than air.
- is insoluble in water but soluble in organic solvents.

## Preparation of ethane

### Activity 6.6

Study carefully the procedure for preparation of methane.

- Predict the chemicals required for preparation of ethane.
- List the apparatus used in preparation of ethane.
- Write the procedure for the preparation of ethane.
- Write an equation for the preparation of ethane.
- What are the physical properties of ethane?
- What are the chemical properties of ethane?

## Trends in physical properties of alkanes

Table 6.3 shows a summary of the physical properties of the first ten alkanes.

- What are the trends in physical properties of alkanes?

Table 6.3: Trends in physical properties of alkanes

No. of carbon atoms	Name of alkane	Melting point (°C)	Boiling point (°C)	Density g/cm <sup>3</sup>	Physical state of alkanes at room temperature	Solubility in water	Solubility in organic solvent
1	methane	-182	-161	0.424	gas	insoluble	soluble
2	ethane	-183	-88	0.546	gas	insoluble	soluble
3	propane	-188	-42	0.501	gas	insoluble	soluble
4	butane	-138	0	0.579	gas	insoluble	soluble
5	pentane	-130	36	0.626	liquid	insoluble	soluble
6	hexane	-95	69	0.657	liquid	insoluble	soluble
7	heptane	-90	99	0.684	liquid	insoluble	soluble
8	octane	-57	126	0.703	liquid	insoluble	soluble
9	nonane	-53	151	0.718	liquid	insoluble	soluble
10	decane	-29	174	0.730	liquid	insoluble	soluble

### The Facts

The trends in physical properties of alkanes is mainly determined by the carbon chain length. As the length of the carbon chain increases the molecular masses also increase hence the melting and boiling points increase. This is evident by the fact that the first four alkanes are gases and the next six are liquids. The increase in melting and boiling points of alkanes with increasing carbon atoms is also caused by the increase in intermolecular forces of attraction. The density also increases with increasing number of carbon atoms. This is due to increase in molecular mass. Alkanes are insoluble in water but highly soluble in non-polar solvents such as methylbenzene and hexane among other organic solvents.

### Chemical properties of methane

The strong Carbon—Carbon and Carbon—Hydrogen covalent bonds make the alkanes relatively unreactive.

## 1. Combustion of methane

Methane burns in air or sufficient oxygen to produce carbon(IV) oxide gas and water.

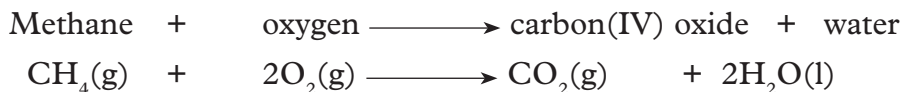

This reaction is exothermic hence methane is a good fuel. If there is insufficient oxygen for complete burning, methane produces carbon(II) oxide and soot. This soot is carbon.

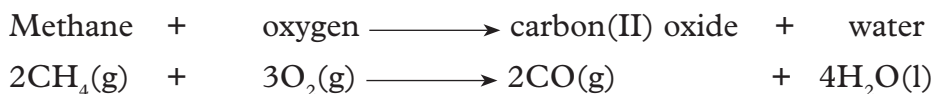

## 2. Substitution reactions of alkanes

Alkanes, react with halogens in the presence of sunlight. They do not react with halogens in the dark, because there is not enough energy which is necessary to start the reaction. Energy is needed to break the halogen bond in the reactants first.

### Substitution reactions of methane with chlorine and bromine

Methane and chlorine react in sunlight or ultra-violet (u.v) light explosively.

They form chloromethane and hydrogen chloride gas. The reaction is exothermic.

Sunlight supplies the energy necessary to start the reaction by splitting the bond between the chlorine atoms (Cl – Cl). The free atoms formed attack methane and products are formed.

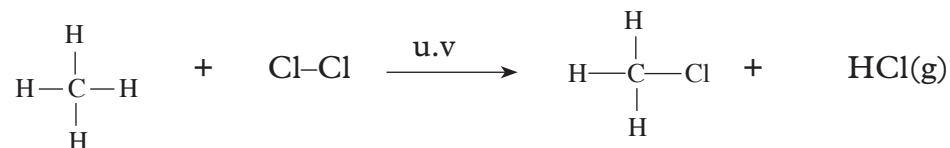

or

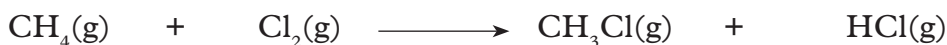

In this reaction, one of the chlorine atoms reacts with methane and replaces (substitutes) a hydrogen atom in the methane molecule. This kind of reaction is called a **substitution** reaction. Hence we say alkanes undergo substitution reactions.

In the presence of excess chlorine, further substitution of hydrogen can occur. Finally all the hydrogen atoms are substituted by chlorine atoms forming tetrachloromethane.

### Example 1

(a) Chloromethane + chlorine  $\xrightarrow{\text{u.v}}$  dichloromethane + hydrogen chloride

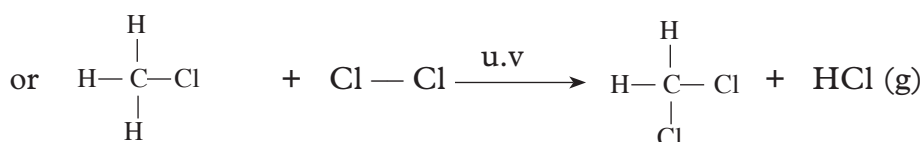
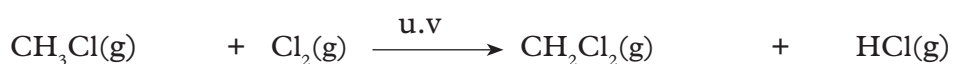

(b) Dichloromethane + chlorine  $\xrightarrow{\text{u.v}}$  trichloromethane + hydrogen chloride

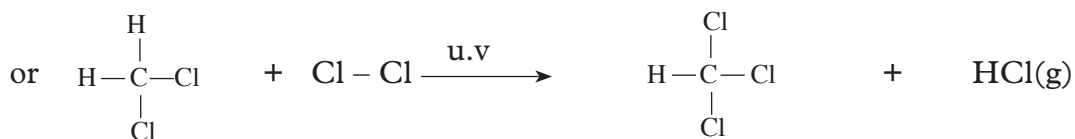

(c) Trichloromethane + chlorine  $\xrightarrow{\text{u.v}}$  tetrachloromethane + hydrogen chloride

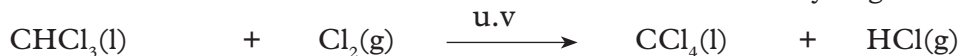

Bromine substitutes the hydrogen atoms in methane in a similar way as chlorine in presence of sunlight. The reactivity of alkanes with halogens increase down the halogens' group.

### Example 2

(a) Methane + bromine  $\xrightarrow{\text{u.v}}$  bromomethane + hydrogen bromide

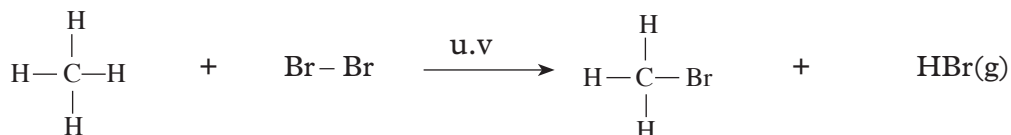

Further substitution reactions can occur. Follow the procedure in example 1 and write equations for the remaining reactions.

## Preparation of ethane

Ethane is prepared in the laboratory by heating a mixture of sodium propanoate and soda lime as shown in Fig 6.3.

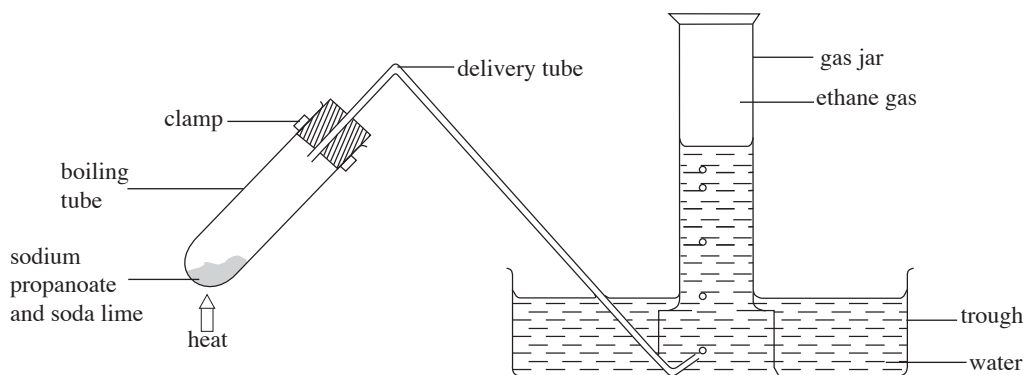

**Fig. 6.3: Preparation of ethane gas**

What is soda lime and why do we use it to prepare ethane gas?

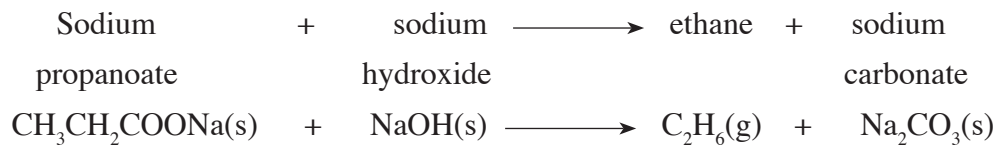

## Physical properties of ethane

- Ethane is a colourless gas.
- It has no smell.
- It is insoluble in water but soluble in organic solvents such as benzene, ether, carbon tetrachloride, etc.

## Chemical properties of ethane

### 1. Combustion

Ethane burns in plentiful supply of oxygen with a clean luminous flame to form

carbon(IV) oxide and water. The reaction is exothermic.

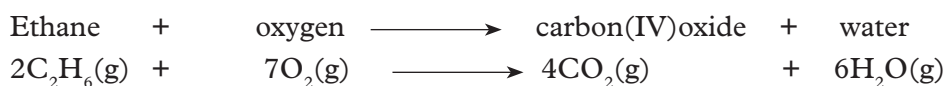

### 2. Substitution reaction with chlorine

Ethane reacts with chlorine in the presence of sunlight or ultraviolet radiation. Energy from sunlight provides energy for the chlorine molecules to split into separate free atoms which are very reactive. One of the chlorine atoms react with ethane to substitute the hydrogen atom. The other chlorine atom combines with the substituted hydrogen atom to form hydrogen chloride gas.

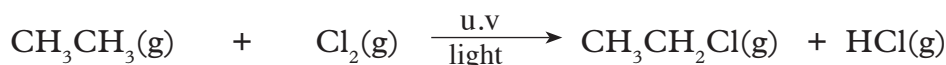
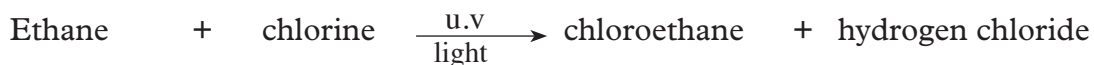

OR

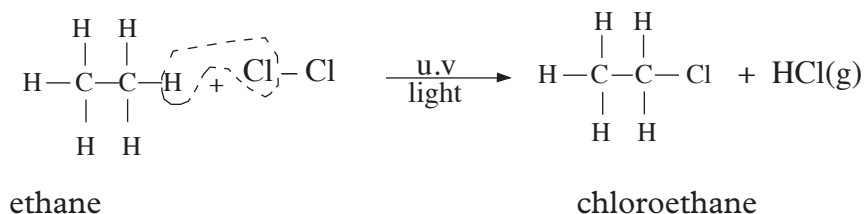



Further substitution can occur. The second substitution can occur in two different positions; that is, on the carbon with a substituted hydrogen atom or on the carbon bearing three hydrogen atoms.

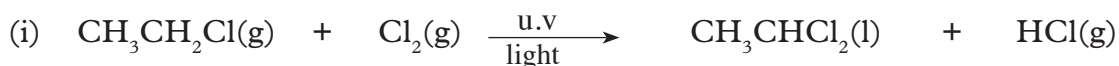
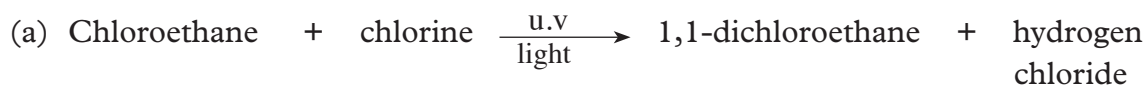

OR

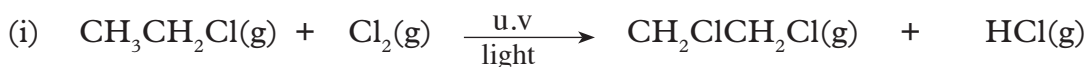
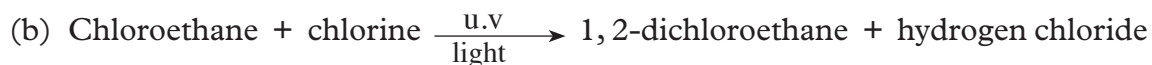
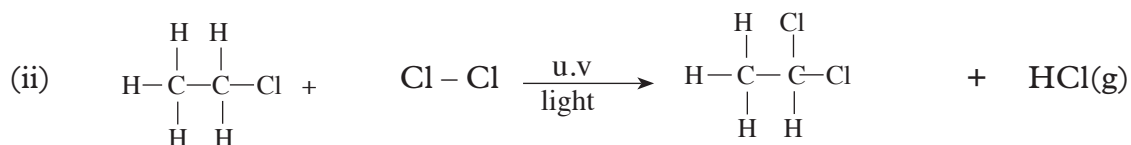

OR

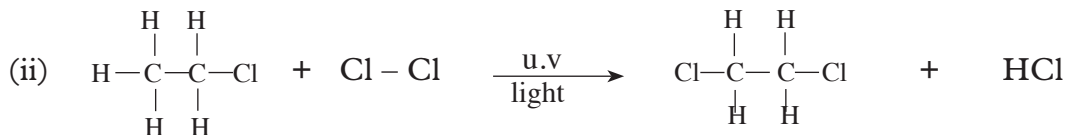

### Work to Do

1. Write down equations for further substitutions of 1, 1-dichloroethane and 1, 2-dichloroethane with chlorine and name the products.
2. When reacted with ethane, bromine substitutes in the same way as chlorine but the reaction is slower. Write both word and structural formulae equations for the substitution reaction of ethane with bromine. Explain why sunlight is required for this reaction.

## Uses of alkanes

1. Most alkanes are used as fuel. Methane is used as biogas in homes. Butane is mainly used as the laboratory gas.
2. Cracking of long chain alkanes is used as a major source of hydrogen gas for the manufacture of ammonia.
3. Alkanes are used in the manufacture of carbon-black which is a component in the printer's ink.
4. They are also used in the manufacture of useful industrial chemicals like methanol, ethanol, and chloromethane.

### Check your progress 6.1

1. In your own understanding explain the meaning of the following:
  - (a) Refining of oil.
  - (b) Fractions as used in oil refining.
2. Why is cracking of alkanes important in the oil industry?
3. Name the following alkanes whose molecular and structural formulas are given below.
  - (a)  $\text{CH}_3\text{CH}_2(\text{CH}_2)_5\text{CH}_2\text{CH}_3$
  - (b)

	H	H	H	H	H	H	H	
H	— C —	C —	C —	C —	C —	C —	C —	H
	H	H	H	H	H	H	H	
  - (c)  $\text{CH}_3\text{CH}_2\text{CH}_2\text{CH}_3$
4. Construct models of methane, ethane and butane.

## 6.3 Alkenes

Alkenes are unsaturated hydrocarbons with one double bond between any two carbon atoms in their structure.

They have general formula  $\text{C}_n\text{H}_{2n}$ , where **n** refers to the number of **carbon** atoms in the molecule see table 6.4.

**Table 6.4: Examples of alkenes; their molecular and structural formulae**

n	Molecular formula	Structural formula	Name
2	$C_2H_4$	$\begin{array}{c} \text{H} \quad \text{H} \\   \quad   \\ \text{H} - \text{C} = \text{C} - \text{H} \end{array}$ <p>or <math>CH_2CH_2</math></p>	Ethene
3	$C_3H_6$	$\begin{array}{c} \text{H} \quad \text{H} \quad \text{H} \\   \quad   \quad   \\ \text{H} - \text{C} = \text{C} - \text{C} - \text{H} \\   \\ \text{H} \end{array}$ <p>or <math>CH_2CHCH_3</math></p>	Propene
4	$C_4H_8$	$\begin{array}{c} \text{H} \quad \text{H} \quad \text{H} \quad \text{H} \\   \quad   \quad   \quad   \\ \text{H} - \text{C} = \text{C} - \text{C} - \text{C} - \text{H} \\   \quad   \\ \text{H} \quad \text{H} \end{array}$ <p>or <math>CH_2CHCH_2CH_3</math></p>	Butene
5	$C_5H_{10}$	$\begin{array}{c} \text{H} \quad \text{H} \quad \text{H} \quad \text{H} \quad \text{H} \\   \quad   \quad   \quad   \quad   \\ \text{H} - \text{C} = \text{C} - \text{C} - \text{C} - \text{C} - \text{H} \\   \quad   \quad   \\ \text{H} \quad \text{H} \quad \text{H} \end{array}$ <p>or <math>CH_2CH(CH_2)_2CH_3</math></p>	Pentene

n	Molecular formula	Structural formula	Name
6	$C_6H_{12}$	$  \begin{array}{cccccc}  & H & H & H & H & H & H \\  &   &   &   &   &   &   \\  H & - C = C - & C - & C - & C - & C - & H \\  & & &   &   &   &   \\  & & & H & H & H & H  \end{array}  $ <p>or <math>CH_2CH(CH_2)_3CH_3</math></p>	Hexene

One member of the alkene, differ from the next or previous one by a  $CH_2$  group. Alkenes also form a homologous series. In the series the members;

- differ by a  $CH_2$  group from the next or previous one.
- have similar chemical properties.
- show steady gradual change in their physical properties.

The  $-C=C-$  double bond in alkene is the functional group. A functional group is the reacting site of a molecule or compound. Most of the reactions of alkenes take place at the  $-C=C-$  bond, where the double bond breaks and the atoms add to the carbon atoms that previously had a double bond.

## Isomers of alkenes

### Remember!

Isomers are molecules that have the same molecular formula but different structural formula.

There are two types of isomers in alkenes:

- Branching isomerism
- Positional isomerism

### (a) Branching isomerism

It occurs when a substituent group is attached to one of the carbon atom in the longest chain containing double bond. For example,

Branching isomerism in pentene

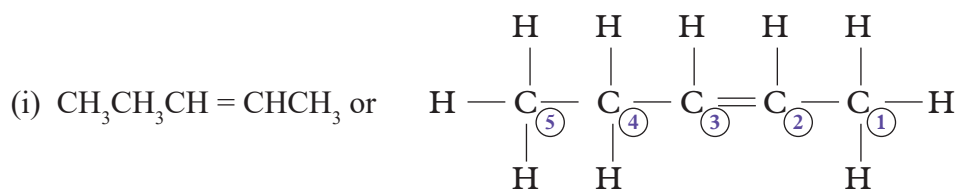

Pent-2-ene

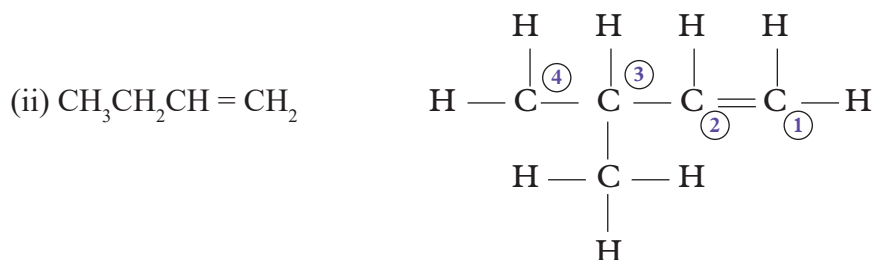

3 methylbut-1-ene

In the second formula a methyl group has been introduced. This changes the structural formula but the molecular formula remains the same.

### (b) Positional isomerism

It occurs when the position of the double bond shifts in an alkenes. For example,

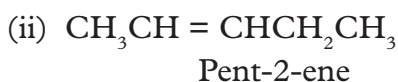

In positional isomerism only the position of the double bond changes.

### Group Task

In groups of twos,

- Draw a positional and branching isomers of  $\text{C}_6\text{H}_{12}$ .
- Draw the elongated structural formula for the following positional isomers above.
  - Pent-1-ene
  - Pent-2-ene

### Naming of isomers

The IUPAC system of nomenclature of naming alkenes uses the following basic rules:

- (i) Identify the longest continuous carbon chain which contains the  $-C=C-$  double bond to get the parent alkene.
- (ii) Number the longest chain from the end of the chain which will give the lowest count to the  $-C=C-$  double bond.
- (iii) Indicate the positions by splitting “alk-positions-ene” e.g. but-2-ene.  
The position indicated must be for the carbon atom at the lower position in the  $-C=C-$  double bond. For example but-2-ene means the double  $-C=C-$  is between carbon numbered “2” and “3”.
- (iv) Position isomers can be formed when the  $-C=C-$  double bond is shifted between carbon atoms e.g.
  - But-2-ene means the double  $-C=C-$  is between Carbon “2” and “3”
  - But-1-ene means the double  $-C=C-$  is between Carbon “1” and “2”
  - Both But-1-ene and But-2-ene are position isomers of Butene.

### Work to Do

1. Name the following isomers of alkenes.
  - (i)  $CH_3CH=CHCH_2CH_3$
  - (ii)  $CH_3CH_2CH_2CH=CH_2$
  - (iii)  $CH_2=CHCH_2CH_2CH_3$
2. Draw and name the positional isomers of  $C_7H_{14}$ .

### Occurrence and extraction of alkenes

At industrial level, alkenes are obtained from the cracking of alkanes. For example, when irradiated with high energy radiation, propane undergoes cracking to form methane gas, ethene and hydrogen gas.

Chemical equation



### Preparation and properties of ethene

#### Activity 6.7

Laboratory preparation of ethene by dehydration of ethanol

#### *Apparatus and chemicals*

- thermometer
- round-bottomed flask
- sand bath
- boiling tube

- cork rubber stopper
- bunsen burner
- delivery tubes
- trough
- beehive shelf
- gas jars
- concentrated sulphuric acid
- ethanol
- bromine water
- acidified potassium manganate(VII)
- broken porcelain / dry sand.

**Caution:** Concentrated sulphuric acid is corrosive. Ethanol and ethene are flammable. There is substantial production of sulphur (IV) oxide in this reaction which can cause irritation and even trigger an asthmatic attack. This experiment should therefore be done in a fume chamber or in open space.

**Procedure**

1. Place about 20 cm<sup>3</sup> of ethanol in a round-bottomed flask and slowly add about 40cm<sup>3</sup> concentrated sulphuric acid, while cooling and shaking the flask.

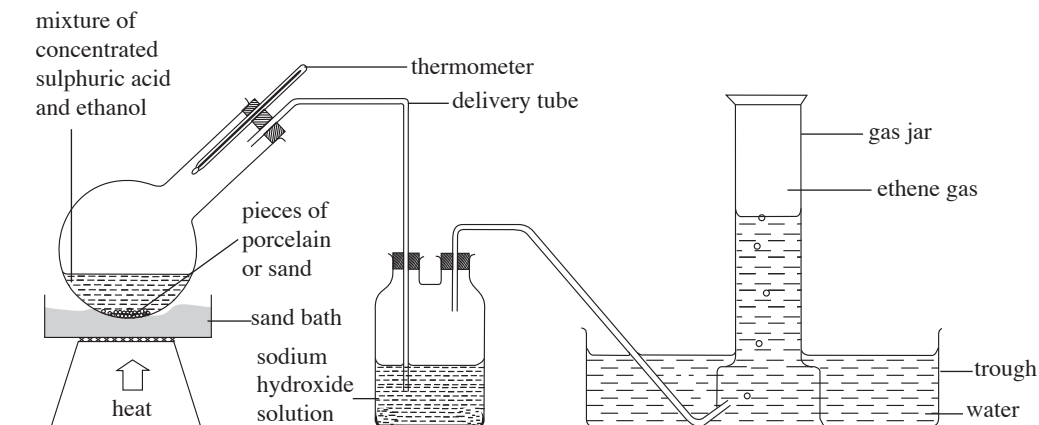

**Fig. 6.4: Laboratory preparation of ethene gas**

2. To the round-bottomed flask, add 2-3 g of clean dry broken pieces of porcelain or sand and assemble the apparatus as shown in Fig 6.4.
3. Heat the flask gently over a sand bath. What do you observe?
4. Allow the gas produced to escape from the delivery tube for a few minutes then collect samples of this gas in a boiling tubes. Close the tube with a cork, then remove the cork and light the gas.

If the tube contains ethene, it burns with a blue flame; if ethene is mixed with air, the mixture in the test tube ignites with an explosion. Allow more gas to escape from the delivery tube until you prove that it is pure ethene. Collect several gas jars of ethene.

- The first portion of the gas evolved is simply displaced hot air from apparatus.
  - Ethene is flammable and it is important not to ignite the gas directly from the delivery tube.
5. Disconnect the delivery tube connecting the round-bottomed flask to the trough before you stop heating.
    - Why must the tube be disconnected before you stop heating?
  6. Bubble the gas through the test tubes containing:
    - (a) bromine water
    - (b) acidified potassium manganate(VII). Record your observations.
      - What do you conclude?
  7. The residue in the flask should be disposed off by first allowing it to cool, and then pouring it into a large volume of cold water.
    - Why is sulphuric acid added into the flask while cooling and shaking the glass?
    - Why should clean, dry broken porcelain or sand be added into the mixture of conc. sulphuric acid and ethanol?
    - Why is it advisable to heat the acid gently?
    - Why does the gas ignite with an explosion if it is not pure ethene?
    - Why must the delivery tube be disconnected from the round-bottomed flask before the heat is turned off?
    - Why should the residue in the flask be first poured into a large volume of cold water when disposing it?

### The Facts

When a mixture of ethanol and concentrated sulphuric acid is heated gently an oily liquid called ethyl hydrogensulphate and water are formed.

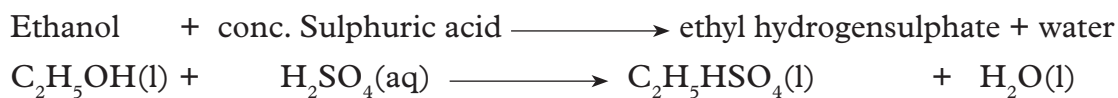



When the mixture is heated to 170°C, a steady stream of ethene is produced. The ethyl hydrogensulphate formed is unstable. It decomposes to sulphuric acid and ethene gas.

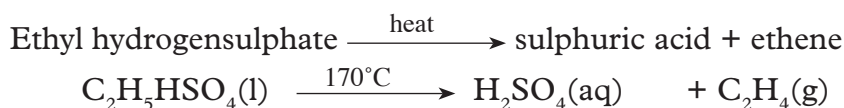

The above chemical reactions are equivalent to the dehydration of ethanol by concentrated sulphuric acid and can be as shown below.

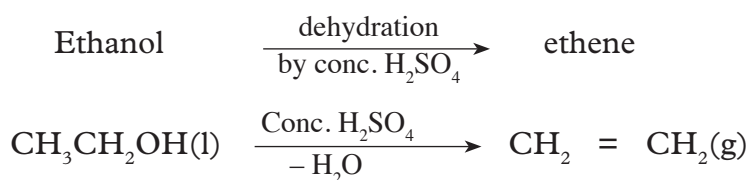

Ethanol contains elements that make up water i.e. hydrogen and oxygen hence water is removed in the above reaction. When concentrated sulphuric acid reacts with this water, a lot of heat is produced i.e. the reaction is extremely exothermic. It is therefore necessary to cool the flask while this reaction is being carried out. Ethanol and concentrated sulphuric acid are miscible although they have different densities. Shaking the flask helps to mix the two liquids properly. Dry broken porcelain increase the surface area on which gas bubbles can form. They also ensure smooth boiling of the mixture.

The mixture of ethanol and the acid is heated gently to prevent a violent reaction which can cause large amounts of sulphuric acid to jump off the flask into the delivery tube. Pure ethene burns with a blue flame, otherwise if mixed with air, it burns with an explosion. That is why the first portion of the gas collected is allowed to escape.

The delivery tube should first be disconnected from the round bottomed flask before we stop heating to prevent water from being sucked back into the flask. The sulphuric acid remaining in the flask as a residue should be diluted by pouring it into a large volume of cold water. This is to dilute the acid so as to make it less corrosive.

**Note:** By dehydrating different alcohols, different alkenes are produced. The general equation for the production of alkenes through dehydration of alcohols is:

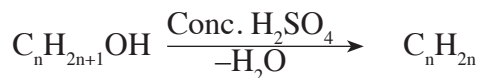
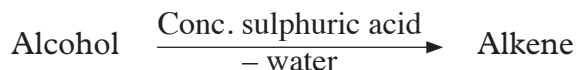

### Cracking hydrocarbons in industry

Alkenes can be obtained from alkanes by heating oil after refining. This process is called **cracking**. Cracking can be done in two ways i.e thermal cracking (heating) or catalytic cracking (heating with a catalyst). Cracking involves breaking long-chain alkane molecules into a shorter alkane and an alkene. For example, when hexane is cracked butane and ethene are obtained.

After distilling the crude oil, too many large hydrocarbons are left behind. The smaller hydrocarbons like petrol, are in great demand. Scientists have found a way to change the larger less useful molecules into smaller, more useful ones.

Cracking helps produce more petrol. The petrol obtained this way is of a better quality than obtained by distillation of crude oil. Cracked petrol is used to blend other petrol to improve quality. When a long carbon chain alkane is cracked (split) at high temperature it produces a shorter alkane and an alkene.

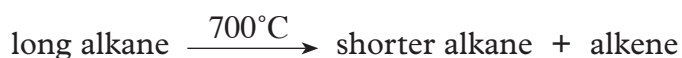

### Example

When a long molecule e.g. decane,  $\text{C}_{10}\text{H}_{22}$ , is cracked it produces octane and ethene.

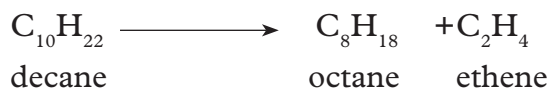

When a catalyst is used, cracking can be made to occur at fairly low temperatures. This is known as **catalytic cracking**.

**Note:** Cracking produces extra petrol and is a source of alkenes.

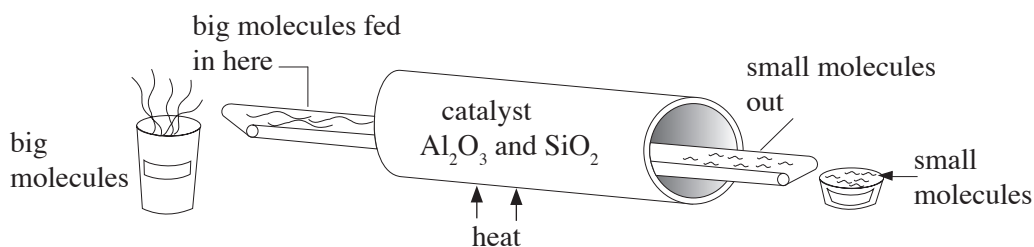

**Fig. 6.5: Cracking large hydrocarbons**

## Trends in physical and chemical properties of alkenes

Table 6.5 shows a summary of physical properties of the first five alkenes. What can you observe about the trends in the physical properties of alkenes?

**Table 6.5: Trends in physical properties of alkenes**

Name of alkene	Formula	Melting point (°C)	Boiling point (°C)	Density (g/cm <sup>3</sup> )	Physical state at room temperature	Solubility in water	Solubility in organic solvent
ethene	C <sub>2</sub> H <sub>4</sub>	-169	-104	—	gas	insoluble	soluble
propene	C <sub>3</sub> H <sub>6</sub>	-185	-47.7	—	gas	insoluble	soluble
but-1-ene	C <sub>4</sub> H <sub>8</sub>	-185	-6.2	—	gas	insoluble	soluble
pent-1-ene	C <sub>5</sub> H <sub>10</sub>	-138	30.0	—	liquid	insoluble	soluble
hex-1-ene	C <sub>6</sub> H <sub>12</sub>	-98	63.9	—	liquid	insoluble	soluble

Alkenes have similar chemical properties and show a steady gradation of physical properties.

- There is increased melting and boiling points as the number of carbon atoms increase. This is because with increasing carbon atoms the molecular mass increases. This also causes an increase in the intermolecular forces of attraction. To break these intermolecular forces, more energy is required hence the increase in melting and boiling points.
- The first three alkenes, i.e. ethene, propene and but-1-ene are gases at room temperature while pent-1-ene and hex-1-ene are liquids. This also has to do with increase in intermolecular forces of attractions.
- Alkenes are organic compounds hence they are insoluble in water but soluble in organic solvents.

### Physical properties of ethene

Ethene is a colourless gas, has no smell and is insoluble in water.

## Chemical properties of alkenes

### (a) Burning/combustion

Alkenes burn with a yellow/luminous sooty or smoky flame in excess air to form carbon(IV) oxide and water.



The characteristic burning of alkenes with a yellow/ luminous sooty or smoky flame is a confirmatory test for the presence of the  $-\text{C}=\text{C}-$  double bond (unsaturation).

A homologous series with  $-\text{C}=\text{C}-$  double or  $-\text{C}\equiv\text{C}-$  triple bond is said to be unsaturated. A homologous series with  $-\text{C}-\text{C}-$  single bond is said to be saturated.

#### Work To Do

In pairs, write equations for combustion of the first three members of the alkene family in excess oxygen and in limited supply of oxygen.

### (b) Addition reactions

An addition reaction is one in which unsaturated compound reacts to form a saturated compound. That is the double bond  $-\text{C}=\text{C}-$  is blown into single  $\text{C}-\text{C}$  bond and the other reagents are added onto it. Examples of addition reaction include:

#### (i) Hydrogenation

Hydrogenation is the addition reaction in which hydrogen in the presence of nickel catalyst and at temperatures of about  $170^\circ\text{C}$  reacts with alkenes to form alkanes. Its major industrial application is converting liquid edible oils into solid fats. When hydrogen gas is passed through liquid vegetable and animal oil at about  $170^\circ\text{C}$  in presence of nickel catalyst, solid fat is formed.

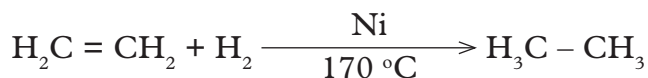

Hydrogenation is thus used to harden oils to solid fat especially margarine.

#### (ii) Halogenation

Halogenation of alkenes is another addition reaction in which a halogen (either fluorine, chlorine, bromine or iodine) reacts with an alkene to form an halogenated alkane. The double bond in the alkene breaks and forms a single bond and halogen is added. For example;

Ethene reacts with bromine to form 1,2-dibromoethane.



### (iii) Reaction with bromine water

Alkenes decolourise bromine water. This reaction is used as test for unsaturated compounds.

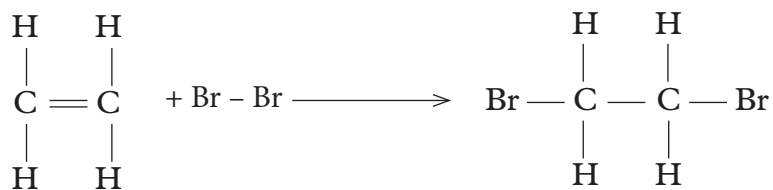

### (iv) Polymerization

Addition polymerization is the process where a small unsaturated monomer alkene e.g. ethene molecule can join together to form a large saturated molecule. Additional polymerization takes place on the double bond site where the double bond breaks and creates room for self addition on both ends.

Addition polymers are named after the parent alkene making the polymer and simply adding the prefix “poly” to the name of monomer.

#### Example of addition polymerization

##### Formation of polyethene

Polyethene is an addition polymer formed when ethene molecules/monomers join together to form a large molecule/polymer at high temperatures and pressure.

During polymerization:

- (i) Many molecules are brought nearer to each other by the high pressure.

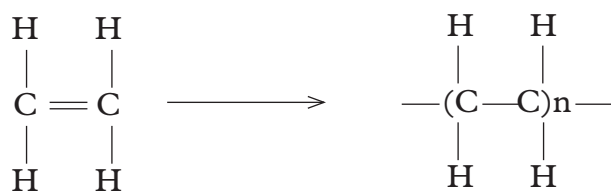

Polyethene

Where n is the number of monomers in the polymer. The number of monomers in the polymer can be determined using the molar mass of the polymer and that of the monomer using the following relationship:

Number of monomers/repeating

$$\text{units in monomer} = \frac{\text{Molar mass of the polymer}}{\text{Molar mass of the monomer}}$$

The commercial name of polyethene is polythene. It is an elastic, tough, transparent and durable plastic.

Polythene is used:

- (i) in making plastic bag
- (ii) other plastic household items e.g. disposable cups or plates, basins, utensils, etc.
- (iii) as packaging materials such as plastic crates.

### Group Task

In groups of three write a report to show how the following polymers are formed and the uses of each. In your report include the environmental impact of each.

- (i) polypropene
- (ii) polyvinyl chloride ( $C=CH_2Cl$ )

### Uses of Alkenes

The following are some of the uses of alkenes:

1. In the manufacture of plastics.
2. Hydrolysis of ethene is used in industrial manufacture of ethanol.
3. In ripening of fruits.
4. In the manufacture of detergents.

### Check your progress 6.2

1. Name the following alkenes:

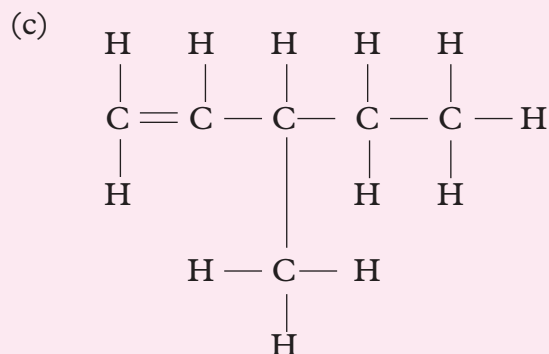
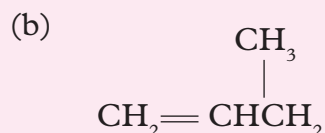

2. Write the structural formulae for the following alkenes.

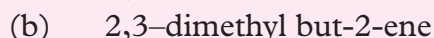

3. In your opinion is there any difference between structural isomers and positional isomers? Explain your answer.

## 6.4: Alkynes

### General formula, nomenclature and structural formulae of alkynes

Alkynes are the third homologous series of hydrocarbons. The general formula is  $C_nH_{2n-2}$ . Like alkenes, alkynes undergo addition reactions and also form polymers.

The first alkyne is ethyne,  $C_2H_2$ . The structural formula of ethyne is as follows:



ethyne

**Note:** Alkynes have a triple bond between two carbon atoms.

### Nomenclature

The names of all alkynes end with *-yne*. The names are derived from respective alkanes where “a” is replaced by “y” as follows:

From

- ethane we get **ethyne**.
- propane we get **propyne**.
- butane we get **butyne**.
- hexane we get **hexyne**, and so on.

Table 6.6 shows the first five members of alkynes. Study the information given.

**Table 6.6: The first five members of alkynes**

Number of carbon atoms	Name	Molecular formula $C_nH_{2n-2}$	Structural formula	Condensed formula of the structure
2	ethyne	$C_2H_2$	$H-C \equiv C-H$	$HC \equiv CH$
3	propyne	$C_3H_4$	$\begin{array}{c} H \\   \\ H-C \equiv C-C-H \\   \\ H \end{array}$	$HC \equiv CCH_3$
4	but-1-yne	$C_4H_6$	$\begin{array}{c} H \quad H \\   \quad   \\ H-C \equiv C-C-C-H \\   \quad   \\ H \quad H \end{array}$	$HC \equiv CCH_2CH_3$
5	pent-1-yne	$C_5H_8$	$\begin{array}{c} H \quad H \quad H \\   \quad   \quad   \\ H-C \equiv C-C-C-C-H \\   \quad   \quad   \\ H \quad H \quad H \end{array}$	$HC \equiv CCH_2CH_2CH_3$
6	hex-1-yne	$C_6H_{10}$	$\begin{array}{c} H \quad H \quad H \quad H \\   \quad   \quad   \quad   \\ H-C \equiv C-C-C-C-C-H \\   \quad   \quad   \quad   \\ H \quad H \quad H \quad H \end{array}$	$HC \equiv CCH_2CH_2CH_2CH_3$

- Construct models for the above structures of alkynes.

## Systematic(IUPAC) naming of alkynes

The rules for naming alkynes are virtually the same as those of alkenes. The “ene” ending is replaced by “yne”. It is important to indicate the position of the triple bond when writing the name of an alkyne. When numbering the carbon chain, start from the end that will give the triple bond the lowest number. Let us consider the following example:

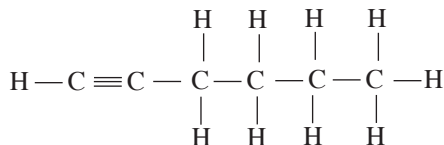

Copy the above structure in your notebook.

- Number the carbon atoms starting from left hand side to the right.
- Number the carbon atoms from right to left below carbon atoms.
- What number should the triple bond get?

This is a *six-carbon chain alkyne*. The triple bond would be found between 1 and 2 if you number the carbon atoms from left to right or 5 and 6 if you number the carbon atoms from right to left. Numbering the carbon atoms from left to right is the better choice because it gives the triple bond the lower number. Therefore the name should be hex-1-yne.

### Work to Do

Name the following molecules:

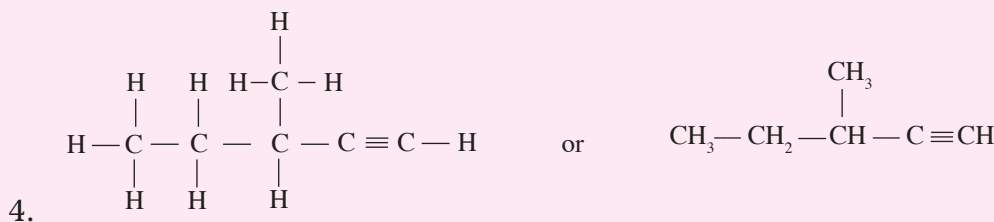
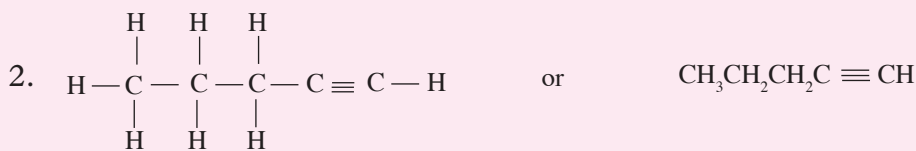



## Rules for naming branched alkynes

1. Determine the largest continuous chain of carbon atoms that has the triple bond between any two carbon atoms. This will give us the parent name of the compound.
2. Number the carbons in the chain so that the triple bond would be between the carbon atoms with the lowest numbers.
3. Identify and name the branching groups attached to this continuous chain of carbons.
4. Write the number of the carbon bearing the branching group in front of the parent name followed by a hyphen.
5. Look at the two carbon atoms between which the triple bond is located. Identify the carbon atom which has the lowest number. For example if the triple bond is found between the second and third carbon atom, the lowest is 2.

Let us try the following example

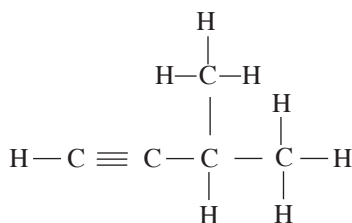

### Step 1

Identify the longest continuous chain of carbon atoms

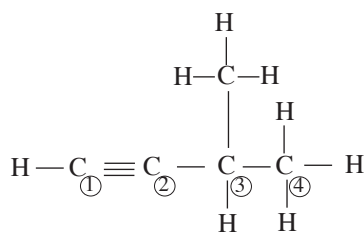

The longest chain is *four carbon atoms* long.

### Step 2

Identify the lowest carbon number on which the triple bond is located.

In the above example the lowest number is 1.

Replace “e” in ene with “y”. Hence, the parent name of the compound is *but-1-yne*.

### Step 3

Identify branching groups

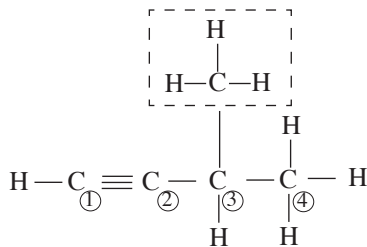

The branching group is a methyl group

It is located on carbon number 3.

### Step 4

Write the number of the carbon bearing the branching group before the name of the group, followed by a hyphen.

- 3 – Methyl

### Step 5

Write the full name of the alkyne.

To write the name of the alkyne, start with the branching group(s) then the parent name.

- 3–methylbut-1-yne.

You can now use the above steps to name any branched alkyne.

### Work To Do

1. Name the following alkynes.

(i)

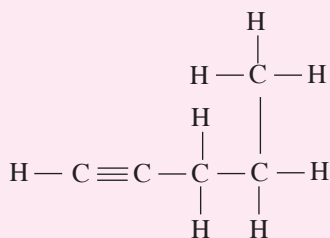

(ii)

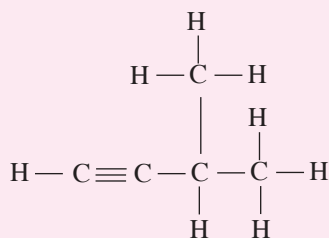

(iii)

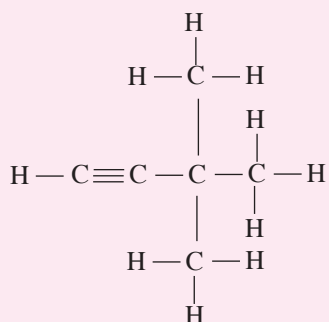

2. Draw the structures of the following compounds

(i) 4 - methylpent-2-yne

(ii) 3 - chloro-3-methylbut-1-yne.

## Isomerism

Isomerism in alkynes is the same as that of alkenes. There are two types of structural isomerism.

- chain isomerism
- position isomerism.

In the following example, we will consider both chain and position isomers of pentyne.

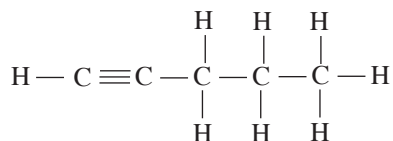

### 1. Chain isomerism

(a) The first isomer is when the carbon atoms are in a continuous chain as shown below.

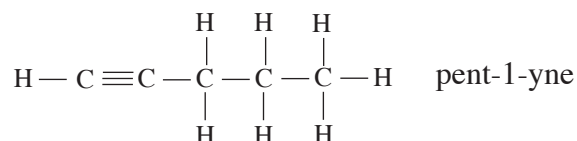

The second isomer is formed when a methyl group is shifted to the third carbon.

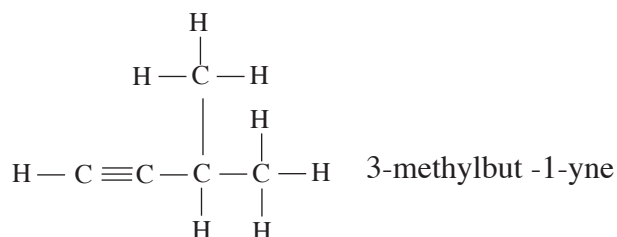

With the chain isomers, we have two isomers; the straight chain alkyne pent-1-yne and one branched 3-methylbut-1-yne.

## 2. Position isomerism

We have two position isomers of pentyne, depending on where the triple bond is placed.

- Pent-1-yne
- Pent-2-yne

Structures of the position isomers.

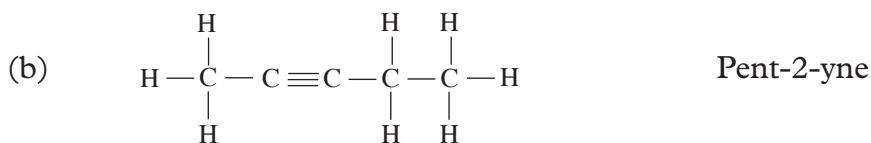
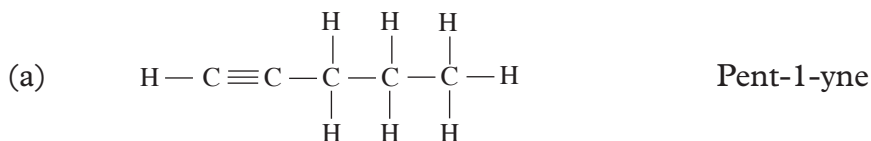

### Work To Do

1. Draw and name all chain and position isomers of hex-1-yne.
2. Draw the structural formula of:
  - (a) but-2-yne
  - (b) 4-methylpent-2-yne
3. Name the following
  - (a)  $\text{CH}\equiv\text{CCH}_2\text{CH}_3$
  - (b)  $\text{CH}_3\text{CH}_2\text{CH}_2\text{C}\equiv\text{CCH}_3$

## Preparation and properties of ethyne

### Activity 6.8

To prepare and investigate the properties of ethyne.

#### Apparatus and chemicals

- flat bottomed flask
- thistle funnel or dropping funnel
- delivery tube
- trough
- beehive shelf
- gas jars
- calcium dicarbide
- water

#### Procedure

1. Cover the bottom of the flask with a thin layer of sand. Ensure that the flask is dry. The reaction between calcium carbide and water produce a lot of heat. Sand is placed in the flask in order to absorb some of the heat produced to prevent the flask from cracking.
2. Add 2-3 lumps of calcium carbide on the sand.
3. Add water dropwise to produce a steady flow of the gas as illustrated in Fig. 6.6.

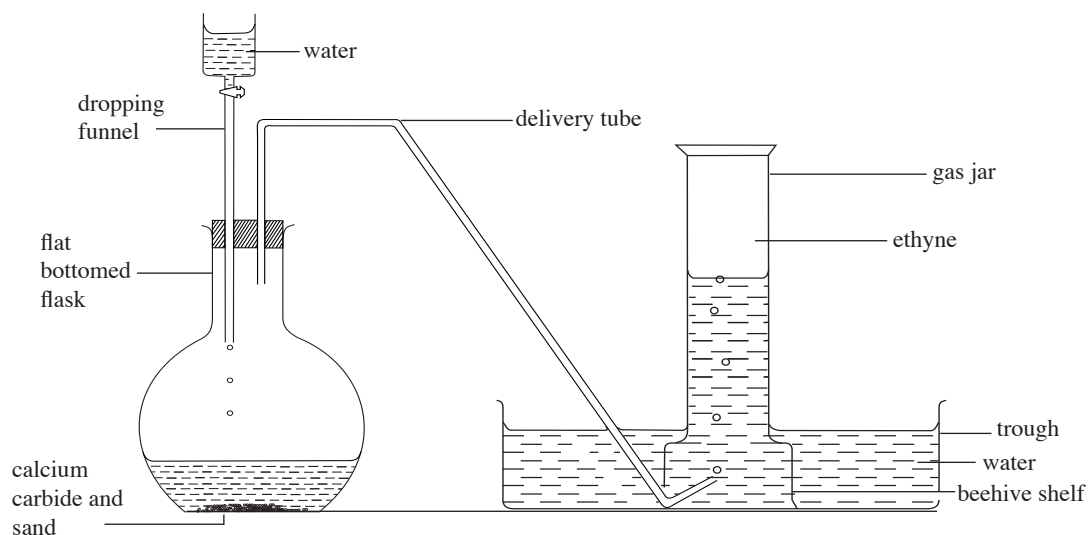

*Fig. 6.6: Laboratory preparation of ethyne*

- What is the colour of ethyne?
- Does it have a smell?
- Why is ethyne collected over water?

4. For the following tests collect two test tubes full of ethyne.
- Place a burning splint at the mouth of one of the test tubes. What do you observe?
  - To the 2nd test tube of ethyne add about 2-3 cm<sup>3</sup> of bromine water and shake well. What do you observe?
5. Record all your observations in your notebook. What do you conclude?  
The reaction that occurs is as in the equation below.

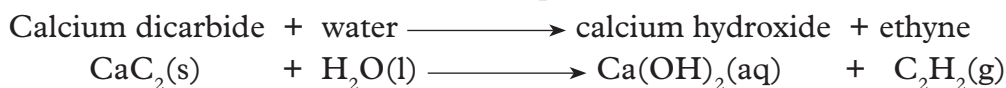

## Physical properties

Ethyne is:

- colourless.
- odourless.
- less dense than air.
- insoluble in water but readily dissolves in organic solvents.

## Trends in physical properties of alkynes

The table below shows a summary of physical properties of alkynes.

**Table 6.7 Trends in physical properties of the first five alkynes**

For- mula	Name	Structural formula	Melting point °C	Boiling point °C	Density g/cm <sup>3</sup>	Solubility in water	Solubility in organic solvents
C <sub>2</sub> H <sub>2</sub>	Ethyne	H-C≡C-H	-82	-75	—	insoluble	soluble
C <sub>3</sub> H <sub>4</sub>	Propyne	HC≡CCH <sub>3</sub>	-101.5	-23	—	insoluble	soluble
C <sub>4</sub> H <sub>6</sub>	But-1-yne	HC≡CCH <sub>2</sub> CH <sub>3</sub>	-122	8.1	—	insoluble	soluble
C <sub>5</sub> H <sub>8</sub>	Pent-1-yne	HC≡CCH <sub>2</sub> CH <sub>2</sub> CH <sub>3</sub>	-98	40	0.695	insoluble	soluble
C <sub>6</sub> H <sub>10</sub>	Hex-1-yne	HC≡CCH <sub>2</sub> CH <sub>2</sub> CH <sub>2</sub> CH <sub>3</sub>	-124	40	0.719	insoluble	soluble

Alkynes are compounds that have physical properties that are similar to those of alkanes and alkenes.

- They are insoluble in water.
- They are soluble in organic solvents like benzene and tetrachloromethane among others. Their densities increase with increase in number of carbon atoms due to increase in molecular mass.

- The boiling points of alkynes increase with increase in number of carbon atoms due to increase in molecular mass and also increase in intermolecular forces of attraction.

## Chemical properties of ethyne

### 1. Combustion of ethyne

Ethyne burns in air with a luminous, smoky flame forming carbon(IV) oxide and water.



Generally alkynes are highly explosive when mixed with air and oxygen. In a limited supply of air, ethyne undergoes incomplete combustion to form a mixture of carbon and carbon(II) oxide.

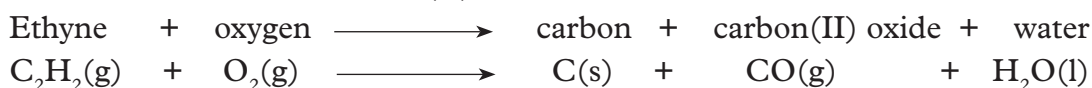

### 2. Addition reactions of alkynes

Because of the unsaturated nature of ethyne, addition reactions occur across the triple bond. Note that two moles of the substance that is reacting are required for complete of saturation.

#### (a) Addition of hydrogen

When ethyne and hydrogen are passed over nickel catalyst at 150°C or over platinum catalyst at room temperature, ethene is first formed and then it is further reduced to ethane.



OR

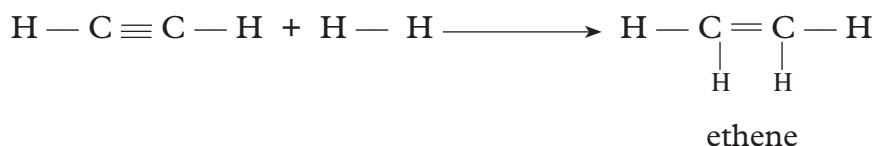

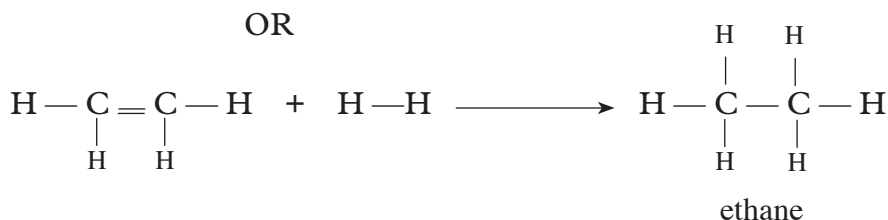

**(b) Addition of halogens( $\text{Cl}_2$ ,  $\text{Br}_2$ )**

We may represent a halogen molecule with  $\text{X}_2$  or  $\text{X} - \text{X}$ . The general reaction of triple bonds with a halogen is as follows:

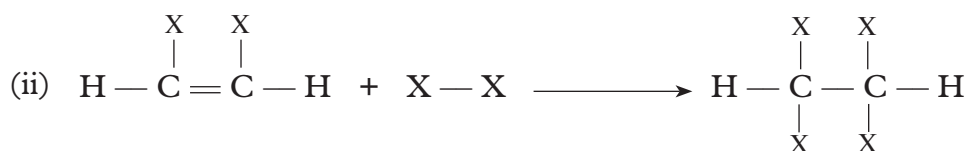
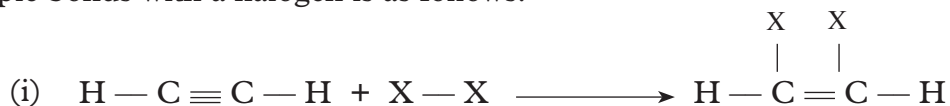

Ethyne reacts explosively with chlorine at room temperature to form hydrogen chloride and carbon.



In controlled situation, ethyne reacts with chlorine and bromine as follows;

(a) Ethyne + chlorine  $\longrightarrow$  1,2-dichloroethene

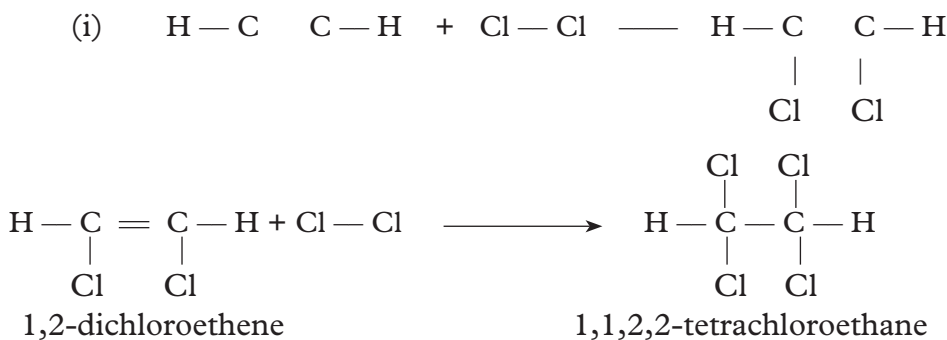
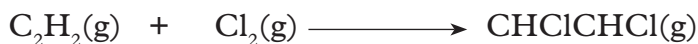

(b) (i) Ethyne + bromine  $\longrightarrow$  1,2-dibromoethene



(ii) 1,2-dibromoethene + bromine  $\longrightarrow$  1,1,2,2-dibromoethene





OR

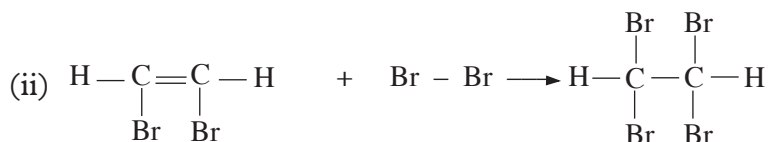
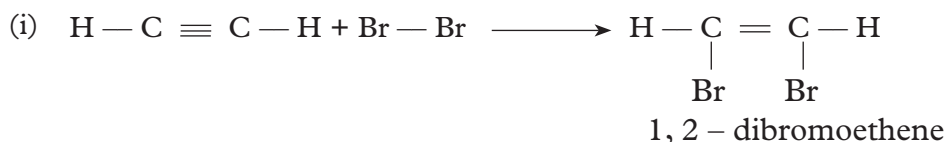

1,1,2,2 - tetrabromoethane

When bromine reacts with ethyne, the red-brown colour of bromine disappears. Bromine finally adds to the carbon-carbon triple bond to form 1,1,2,2-tetrabromoethane. The decolourisation of bromine as mentioned earlier is the test used to detect for unsaturation in a molecule.

### (c) Addition of hydrogen halides

Ethyne reacts with hydrogen halides. The vigour of reaction of ethyne with hydrogen halides increases as follows;  $\text{HI} > \text{HBr} > \text{HCl} > \text{HF}$  so that hydrogen iodide add most readily to ethyne at room temperature. A similar reaction occur with hydrogen bromide at  $100^\circ\text{C}$ . The reaction with hydrogen chloride occurs very slowly.

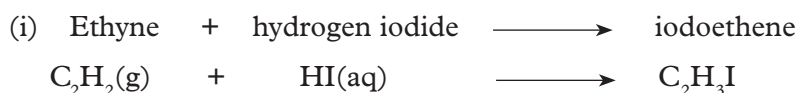

OR

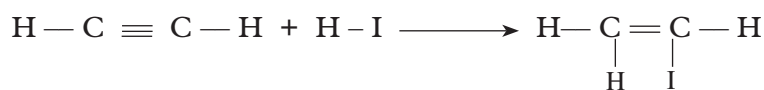

iodoethene

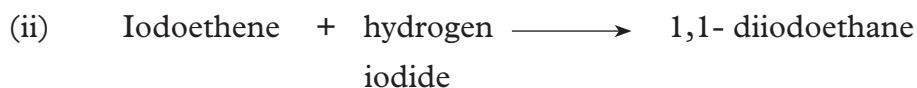

OR

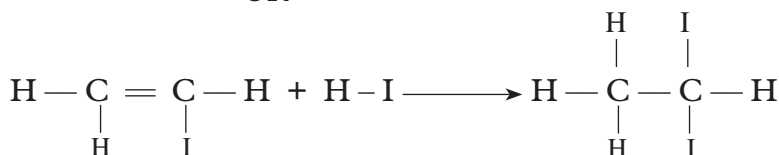

Follow the above procedure to predict the word equation and chemical equation of addition reaction of hydrogen bromide or hydrogen fluoride with ethyne.

### Uses of alkynes

1. Ethyne burns in oxygen to give a very luminous flame. This is why it is used to produce light in lamps.
2. Ethyne is used in oxy-acetylene flame for metal cutting and welding Fig. 3.9(a).
3. Some alkynes are used for manufacture of plastics, synthetic rubbers, synthetic fibres, adhesives and other things Fig. 3.9(b),(c),(d), (e), (f).

### Check your progress 6.3

1. What is the molecular formula of but-1-yne? Draw its structural formula.
2. Draw and name the structural formula for all the isomers of but-1-yne.
3. Why do you think that alkynes are more reactive than the alkanes and alkenes?
4. Write an equation to show the complete combustion of ethyne in oxygen.
5. List three uses of ethyne.

## 6.5 Alkanols (Alcohols)

Alkanols belong to a homologous series of organic compounds with a general formula  $C_nH_{2n+1}OH$ . The  $-OH$  is the functional group. Table 6.8 shows the first five alkanols.

Table 6.8: Examples of alkanols

n	Molecular formula	Condensed formula	Structural formula	IUPAC name
1	CH <sub>3</sub> OH	CH <sub>3</sub> OH	$\begin{array}{c} \text{H} \\   \\ \text{H} - \text{C} - \text{OH} \\   \\ \text{H} \end{array}$	Methanol

n	Molecular formula	Condensed formula	Structural formula	IUPAC name
2	$C_2H_5OH$	$CH_3CH_2OH$	$  \begin{array}{c}  H \quad H \\    \quad   \\  H - C - C - OH \\    \quad   \\  H \quad H  \end{array}  $	Ethanol
3	$C_3H_7OH$	$CH_3(CH_2)_2OH$	$  \begin{array}{c}  H \quad H \quad H \\    \quad   \quad   \\  H - C - C - C - OH \\    \quad   \quad   \\  H \quad H \quad H  \end{array}  $	Propanol
4	$C_4H_9OH$	$CH_3(CH_2)_3OH$	$  \begin{array}{c}  H \quad H \quad H \quad H \\    \quad   \quad   \quad   \\  H - C - C - C - C - OH \\    \quad   \quad   \quad   \\  H \quad H \quad H \quad H  \end{array}  $	Butanol
5	$C_5H_{11}OH$	$CH_3(CH_2)_4OH$	$  \begin{array}{c}  H \quad H \quad H \quad H \quad H \\    \quad   \quad   \quad   \quad   \\  H - C - C - C - C - C - OH \\    \quad   \quad   \quad   \quad   \\  H \quad H \quad H \quad H \quad H  \end{array}  $	Pentanol

### Group Task

In pairs, practise drawing the condensed and structural formula for the following alkanols.

- (i) Hexanol
- (ii) Heptanol
- (iii) Octanol

Alkanols form a homologous series:

### Laboratory preparation of ethanol

Alcohol is prepared in the laboratory by **fermentation** process.

Fermentation is the reaction where sugar is converted to ethanol (alkanol) using yeast as a catalyst.

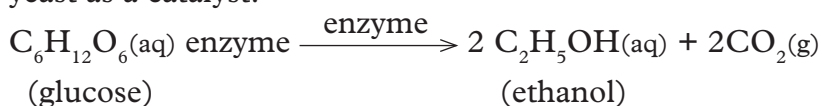

At concentration greater than 11% by volume, the ethanol produced kills the yeast enzyme stopping the reaction. Normally, to increase the concentration, of alcohol, **distillation** is done.

### Chemical properties of alkanols

#### 1. Burning

They burn in excess oxygen with an almost colourless non-sooty **blue** flame to form **carbon dioxide**. Ethanol is thus a saturated compound like alkanes.

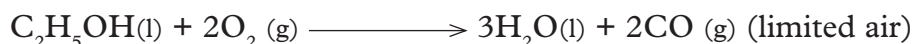
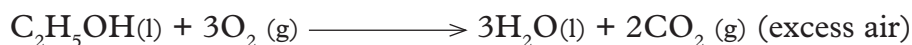

Due to its flammability, **ethanol** is used;

- (i) as a fuel in spirit lamps.
- (ii) as gasohol when blended with gasoline.

#### 2. Reaction of alcohols with alkanolic acids (esterification)

Alkanols react with alkanolic acids to form a group of homologous series of sweet smelling compounds called **esters**. Water is also produced.

Concentrated sulphuric (VI) acid is used as a catalyst.

The process of formation of esters is known as esterification.



Esters derive their names from the alkanol and alkanolic acid used.

The alkanol “becomes” an alkyl group and the alkanolic acid “becomes” alkanoate hence the alkylalkanoate. For example.

- a. Ethanol reacts with ethanoic acid to form the ester, ethylethanoate and water.

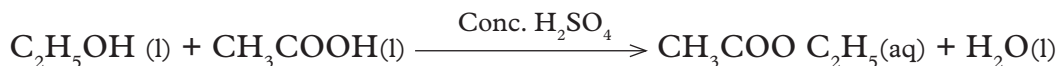

- b. Ethanol reacts with propanoic acid to form the ester ethylpropanoate and water.



## Uses of some alkanols

- (a) Methanol is used as industrial alcohol and making of methylated spirit
- (b) Ethanol is used:
1. As alcohol in alcoholic drinks e.g. beer, wines and spirits.
  2. It is also used as antiseptic to wash wounds.
  3. Ethanol is used as a fuel when blended with petrol to make gasohol.

### Check your progress 6.4

1. Write the molecular formula and draw the structure for
  - (a) Pentan-1-ol
  - (b) Heptan-1-ol
2. In your judgement, why do you think alkanols make good fuels?

## 6.6 Alkanolic acids

Alkanolic acids are organic acids which are sometimes called **carboxylic acids**. They are so called because they have a carboxyl group as their functional group. They may be regarded as being derived from alkanes by replacing one of the hydrogen atoms with a  $\text{-COOH}$  group. Alkanolic acids form homologous series with a general formula  $\text{R-COOH}$  where R is an alkyl group or H in case of the first one. We use the general formula  $\text{C}_n\text{H}_{2n+1}\text{COOH}$  to calculate their molecular formula.

## General formula and nomenclature of alkanolic acids

The systematic name of a carboxylic acid comes from an alkane with the corresponding number of carbon atoms. The **-e** in the name of alkane is replaced with **-oic acid**. Let us name and draw the structures of the first three alkanolic acids.

- The first member of the series is methanoic acid with the formula HCOOH. In methanoic acid, R is represented by H while for the rest of the members, R is represented by an alkyl group. The structure of the carboxyl group is

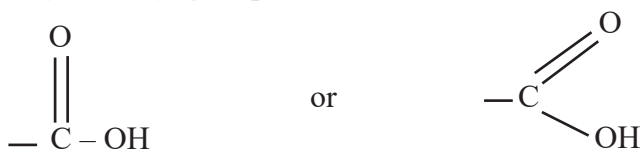

The structure of methanoic acid is therefore,

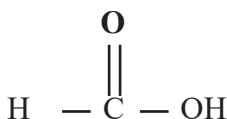

- The second member of the alkanolic acid is ethanoic acid, which has two carbon atoms. Since one of the carbon atoms is already attached to the functional group, the value of  $n$  in the general formula  $\text{C}_n\text{H}_{2n+1}\text{COOH}$  is 1. When we substitute, we get the molecular formula for ethanoic acid as follows.

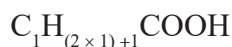

The structural formula is represented as

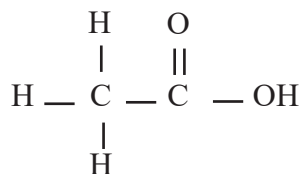

Ethanoic acid

For the third member;  $n = 2$  we substitute in  $\text{C}_n\text{H}_{(2n+1)}\text{COOH}$  i.e.

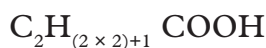

hence we get  $\text{C}_2\text{H}_5\text{COOH}$  as the molecular formula. This can also be written as



It is called propanoic acid and its structural formula is as follows.

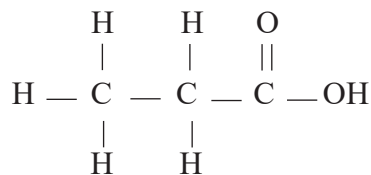

Propanoic acid

Table 6.5 below shows examples of alkanoic acids.

Table 6.9 The first 2 alkanoic acids

Name	Molecular formula	Structural formula
Methanoic acid	HCOOH	$  \begin{array}{c}  \text{O} \\     \\  \text{H} - \text{C} - \text{OH} \\  \text{or} \\  \text{HCOOH}  \end{array}  $
Ethanoic acid	CH <sub>3</sub> COOH	$  \begin{array}{c}  \text{H} \quad \text{O} \\    \quad    \\  \text{H} - \text{C} - \text{C} - \text{OH} \\    \\  \text{H} \\  \text{or} \\  \text{CH}_3\text{COOH}  \end{array}  $

### The alkanoic acids as a homologous series

The alkanoic acids are another homologous series of organic compounds with the following characteristics

- They have the functional group -COOH attached to the hydrocarbon chain
- The members have a general formula C<sub>n</sub>H<sub>2n+1</sub>COOH or RCOOH, where n = 0, 1, 2, .....
- Members of the series differ from the next by a -CH<sub>2</sub>- group.
- They have similar chemical properties.
- They show a gradual increase in physical properties such as melting points, boiling points and density.

#### Work To Do

1. Name alkanoic acids with the following carbon atoms; 4, 5, 6, 7, 8, 9.
2. Draw the structures of the above alkanoic acids.
3. Write the formulae of the above alkanoic acids.

## Preparation of alkanolic acids

Alkanolic acids can be prepared by oxidation of the corresponding alcohol in two steps. The oxidising agents are:

- acidified potassium dichromate(VI)
- acidified potassium manganate(VII)

The corresponding alcohol is mixed with excess acidified potassium dichromate(VI) and warmed.

The first step forms an alkanal and water as shown in the following general equation.

R represents an alkyl group

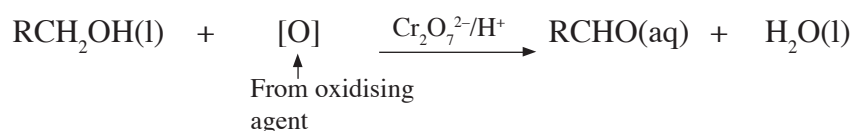
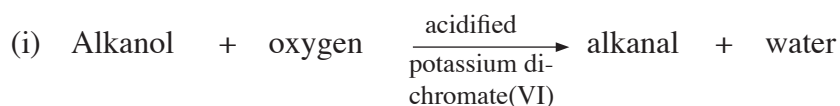

The second step involves further oxidation of alkanal to alkanolic acid i.e.

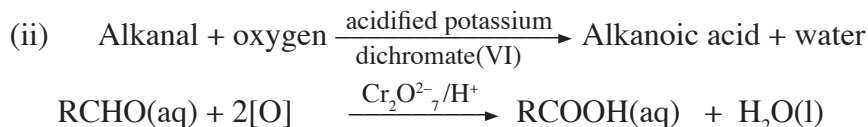

Therefore, the overall reaction is:

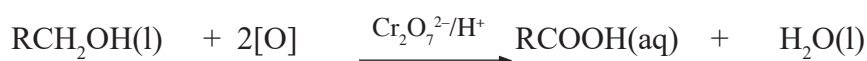
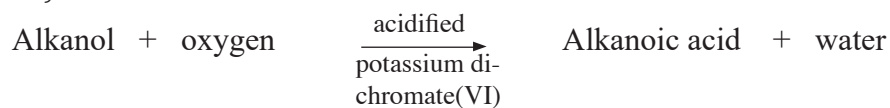

### Example: Preparation of ethanoic acid

Ethanoic acid is prepared by warming a mixture of ethanol and excess acidified potassium dichromate(VI) or excess acidified potassium manganate(VII).



## Step I

This involves the conversion of **ethanol** to **ethanal** as shown below. This is a slow process.

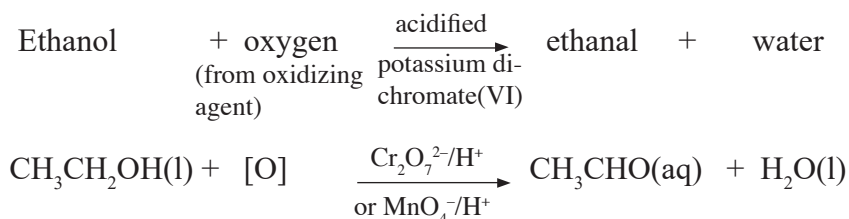

OR

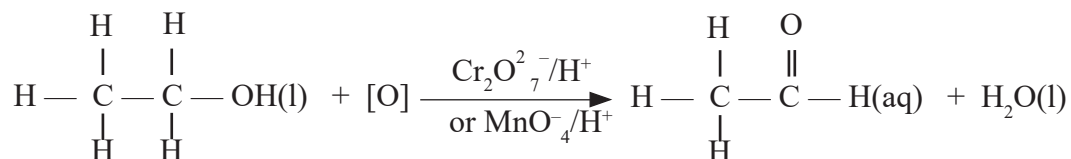

## Step II

In this step, the ethanal is oxidised to ethanoic acid. This reaction takes place at a much faster rate.

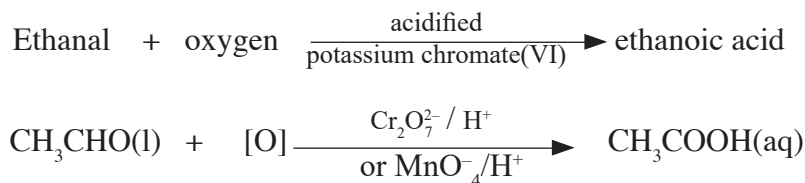

OR

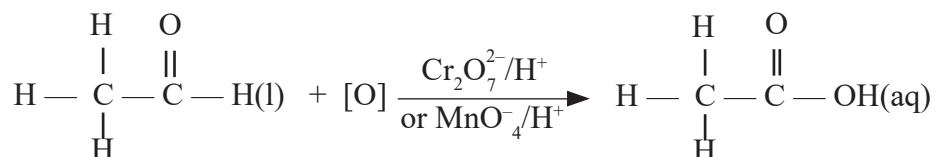

## General equation for the preparation of alkanolic acids

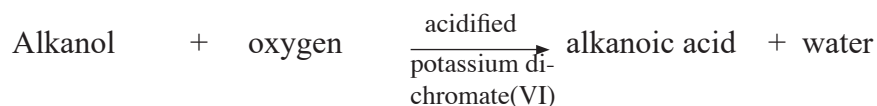

Eventually, the orange colour of potassium dichromate (VI) turns green as the oxidation progresses or if we use potassium manganate(VII), the purple colour turns colourless. The acid is obtained from the mixture by distillation at its boiling point while testing the distillate. Distillation is stopped when the distillate is no longer acidic.

## Work To Do

1. Name the chemical reagents required in the preparation of butanoic acid.
2. Write down an outline of the procedure required in the above preparation.
3. Write step by step equations for the preparation of butanoic acid.
4. Write a general word equation for the preparation of butanoic acid.
5. List the characteristics of homologous series of alkanolic acid.

## Properties of alkanolic acids

### Physical properties of alkanolic acids

- The first ten straight chain alkanolic acids are liquids at room temperature.
- The first few members like methanoic and ethanoic acids are soluble in water. The rest are insoluble and actually float in water. The solubility of alkanolic acids generally decreases with increasing molecular mass.
- Table 6.10 shows the physical properties of some alkanolic acids.

Table 6.10 Trends in physical properties of alkanolic acids

Name	Melting point (°C)	Boiling point (°C)	Density g/cm <sup>3</sup>	Solubility in water
Methanoic acid	8.4	101	1.220	Soluble
Ethanoic acid	16.6	118	1.049	Soluble
Propanoic acid	-20.8	141	0.992	Soluble
Butanoic acid	-8	164	0.964	Soluble
Pentanoic acid	-19	187	0.939	Slightly soluble
Hexanoic acid	-3	205	0.927	Slightly soluble
Heptanoic acid	-10.5	223	0.920	Slightly soluble
Octanoic acid	16	239	0.910	Slightly soluble
Nonanoic acid	11	253	0.907	Slightly soluble
Decanoic acid	31	269	0.905	Slightly soluble

As shown in the table above, the boiling and melting points of the alkanolic acids increase gradually as the length of the hydrocarbon chain increases except for a few discrepancies in the melting points. The increase is due to the following reasons.

- As the length of the hydrocarbon increases, the weak intermolecular forces (Van der Waals forces) are increased.

- There is also formation of hydrogen bonds between the alkanolic acid molecules. This is brought about by the partial positive and negative charges on the H and O atoms of the carboxyl group (-COOH). These charges enable the molecules to attract each other and form strong hydrogen bonds.

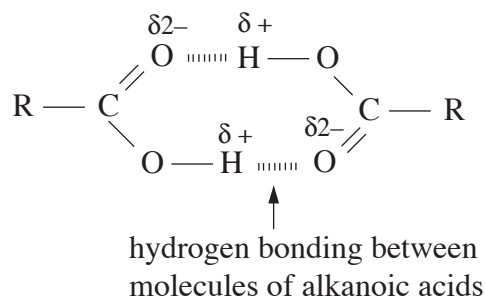

### Work To Do

1. Describe the trend in melting and boiling points of the first ten alkanolic acids.
2. Compare the answer in (1) above with their corresponding alkanes. Explain their differences.
3. Compare the solubility of the first four alkanolic acids in water with those of alkanes. Explain the differences.

## Chemical properties of alkanolic acids

Alkanolic acids are another homologous series of organic compounds that have similar chemical properties. In these series, we will learn about the properties of ethanoic acid as a representative of alkanolic acids. Ethanoic acid is a colourless liquid with a sharp smell.

### Activity 6.9

*To investigate the chemical properties of ethanoic acid.*

#### **Apparatus and chemicals**

- |                             |  |
|-----------------------------|--|
| • test tubes                | • droppers                             |
| • beaker                    | • universal indicator or litmus papers |
| • spatula                   | • test tube holder                     |
| • source of heat            | • calcium carbonate                    |
| • magnesium ribbon          | • ethanol                              |
| • ethanoic acid             | • concentrated sulphuric acid          |
| • sodium hydroxide solution | • phenolphthalein indicator            |

#### **Procedure**

Copy Table 6.11 in your notebook. Follow the procedures as outlined in the table and record your observations and conclusions in the spaces provided.

**Table 6.11 Investigating chemical properties of alkanolic acids**

Procedures	Observations	Conclusions
1. Place about 2 cm <sup>3</sup> of ethanoic acid in a test tube. Add a few drops of universal indicator or test with litmus papers.		
2. Place about 2 cm <sup>3</sup> of ethanoic acid in a test tube. Add a small piece of clean magnesium ribbon and test for any gas produced.		
3. Place about 2 cm <sup>3</sup> of ethanoic acid in a test tube. Add a spatula endful of calcium carbonate and test for any gas produced.		
4. Place about 2 cm <sup>3</sup> of ethanoic acid in a test tube. Add an equal amount of ethanol followed by two drops of concentrated sulphuric acid. Warm the mixture gently and pour the resulting mixture into a beaker with about 60 cm <sup>3</sup> of cold water. Smell the product.		
5. Place about 2 cm <sup>3</sup> of ethanoic acid in a test tube. Add two drops of either phenolphthalein or methyl orange indicator. Then add 2 cm <sup>3</sup> sodium hydroxide solution to the mixture drop by drop until there is colour change.		

When we dissolve mineral acids in water, they dissociate into their respective ions. For example, HCl produces hydrogen ion H<sup>+</sup>, as well as the chloride ion Cl<sup>-</sup> on dissolution in water. Similarly, when an alkanolic acid is dissolved in water, it dissociates to form hydrogen ion, H<sup>+</sup> and carboxylate anion, RCOO<sup>-</sup> as illustrated in the following general equation.



OR

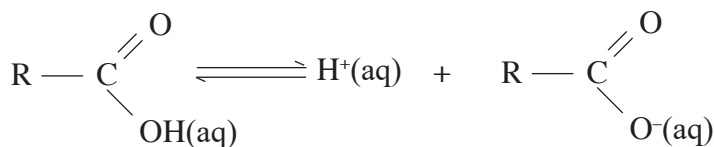

Carboxylic acid

Carboxylate anion

**Note:** The functional group,  $-\text{COOH}$  donates the  $\text{H}^+$  ion, not the alkyl group represented by R.

Ethanoic acid is said to be a weak acid. It partially dissociates into ions in water.

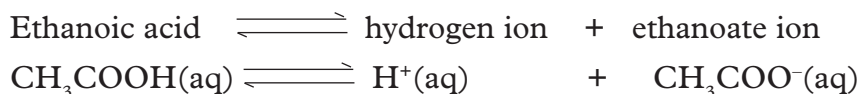

An aqueous solution of ethanoic acid has a pH of about 4.7

A solution of ethanoic acid will show characteristic reactions of a dilute acid as follows:

### 1. Reaction of ethanoic acid with carbonates

Ethanoic acid will react with carbonates to produce a salt, carbon(IV) oxide and water. For example, it reacts with calcium carbonate to give calcium ethanoate, carbon(IV) oxide and water.

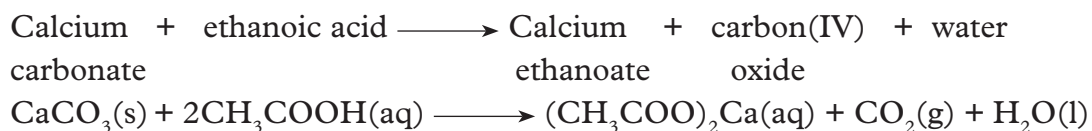

**Note** that for an organic salt formula, the metal is written last. But, when naming the salt, we start with the metal.

### 2. Reaction of ethanoic acid with metals

Ethanoic acid reacts with reactive metals like magnesium to produce a salt and hydrogen gas. To understand this, let us first start with a reaction that we are familiar with.



Magnesium displaces hydrogen from the acid to form magnesium chloride.

In organic acids, the metal displaces hydrogen from the carboxyl group ( $-\text{COOH}$ ) of the alkanolic acid as shown in the following general equation.



Now, let us look at the reaction of magnesium with ethanoic acid.

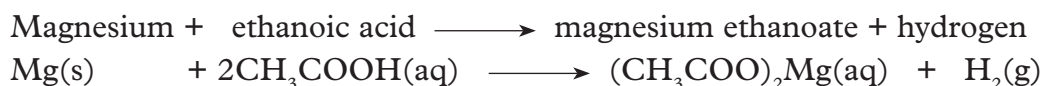

**Note** that the metal displaces hydrogen in the  $-\text{COOH}$  group and **not** the other hydrogens.

### 3. Reaction of ethanoic acid with bases

Ethanoic acid reacts with bases to form salt and water. In experiment 6.3, it reacted with sodium hydroxide as follows:

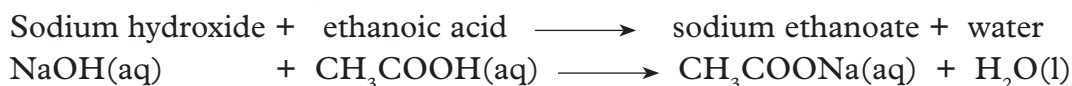

#### 4. Reaction of ethanoic acid with ethanol

In general, when organic acids are reacted with alkanols, they form **esters** in the process of **esterification** as we had seen earlier. Ethanoic acid will react with ethanol in the presence of a few drops of concentrated sulphuric acid to form ethyl ethanoate. Concentrated sulphuric(VI) acid is a catalyst for the reaction.

Ethanoic acid + ethanol  $\rightleftharpoons$  ethyl ethanoate + water  
(ester)

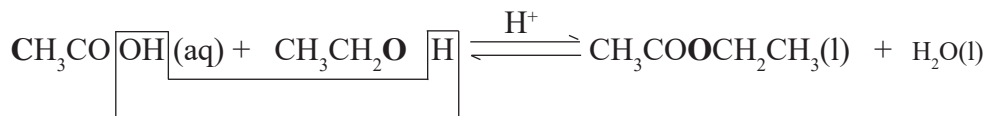

Ethyl ethanoate is one example of an ester.

**Note:** Always remember that the *first part* of the ester is derived from the acid while the *second part* is derived from the alcohol. In writing the name of the esters, we start with alcohol part and end with the acid part.

#### The process of esterification

In esterification, the *hydroxyl group* from the acid combines with the *hydrogen atom* from the hydroxyl group of alcohol to form water and the remaining parts combine to form the ester.

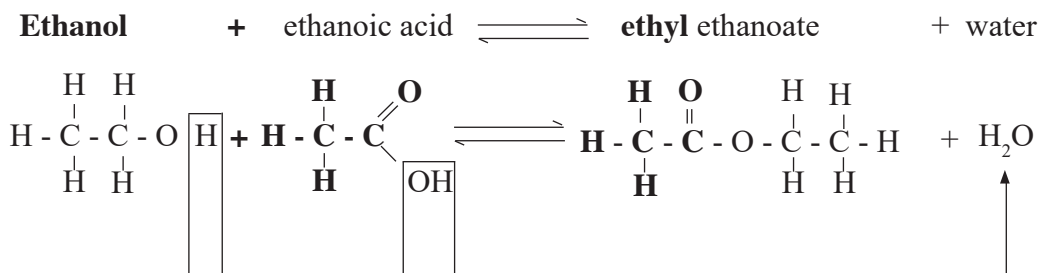

Esters have the general formula  $\text{RCOOR}'$ . In the above example, R represents  $\text{CH}_3-$  from ethanoic acid and  $\text{R}'$  represents  $\text{CH}_3\text{CH}_2-$  from ethanol.

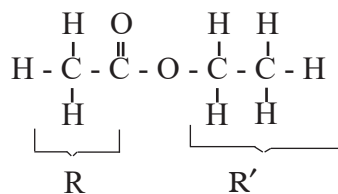

The general structure of an ester is represented as

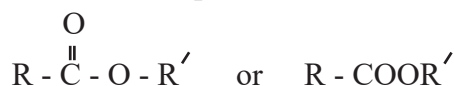

R and R' represent alkyl groups which are not necessarily equal in carbon chain length, but depends on the acid and alcohol used.

Esters form a homologous series of compounds that have strong pleasant smells. Esters are responsible for many of odours in flowers and flavours in fruits. Flowers and fruits have natural esters. For example, the fruity smell of a banana is because of a particular ester; the fruity smell of a pineapple is because of another ester and so on. They have also been used in food flavourings and perfumes.

We have seen that an alcohol and an organic acid react to produce an **ester** and **water** through the process of esterification. Earlier, we also learnt that an alkali and a mineral acid react to form **salt** and **water** in a neutralisation process. The differences between esterification and neutralisation reactions are listed below. Table 6.12 summarises the differences between these two important processes.

**Table 6.12 Comparison of esterification and neutralisation**

Esterification	Neutralisation
1. The reaction is slow.	1. Fast or instantaneous.
2. Reaction is reversible.	2. Irreversible.
3. Forms esters and water.	3. Forms salts and water.
4. Heat or catalyst required.	4. No heat or catalyst required.
5. The esters formed are molecules and in water they do not conduct electricity.	5. Salts formed are ionic, in solution form they are electrolytes.

When esters are boiled with alkalis, they break up. During hydrolysis, we get the acid and alcohol used to form the same ester. This process is called **ester hydrolysis**.

### *Example*

You are given the following ester to hydrolyse,  $\text{CH}_3\text{COOCH}_2\text{CH}_3$ .

Determine the acid and the alcohol that were used to form it.

### *Solution*

There are 2 things to remember before you solve this problem.

- The **first portion** of the ester is from the acid.
- The **last portion** is from the alcohol.

The oxygen atom bridging the two portions is from the alcohol.

Let us start with the last part of the ester.

- Cut the molecule as shown below, leaving the alcohol part with an oxygen atom and the acid part also with an oxygen atom.



We know that the alcohol ends with  $\text{-OH}$ .

Add a 'H' atom on the alcohol part.



Write the formula in the usual way to get the alcohol used.



Name the alcohol i.e. **ethanol**

(b) The acid must end with  $\text{OOH}$ .

In the acid part, we already have one 'O' atom. Add the remaining **O** and **H** atoms to get the acid.



Name the acid i.e. **ethanoic acid**.

## Uses of ethanoic acid

Ethanoic acid is one of the world's most important chemicals. It serves as an intermediate in the production of various products as indicated below.

- It is used in the manufacture of a wide range of polymers e.g. ethyl ethanoate which is used in adhesives and others for films, paints, textiles and paper.
- Ethanol is used in production of ethanoic anhydride used in the manufacture of pharmaceuticals like aspirin, bleaching agents in detergents; agro-chemicals (like herbicides) and dyes.
- It is used in the manufacture of butyl ethanoate which is used in the production of many paints, dyes, adhesives and ink.
- Chloroethanoic acid is used in the production of wallpaper, adhesives, herbicides, pharmaceuticals and cosmetics.

### Check your progress 6.5

1. Methanoic acid is added to the same volume of ethanol in the presence of concentrated sulphuric acid and warmed.
  - (i) What is the name of the ester formed?
  - (ii) Write an equation for the reaction in (i).
2. Ethanoic acid is a weak acid. Explain.
3. Explain why the boiling point of ethanoic acid ( $118^\circ\text{C}$ ) is higher than that of propan-1-ol (b.p.  $97^\circ\text{C}$ ) and yet they have the same molecular mass.
4. Which ester forms from the reaction between methanol and ethanoic acid? Write a word equation for the reaction.
5. The following ester,  $\text{HCOOCH}_3$ , was hydrolysed. Write the formula and names of the organic acid and alcohol used to form the ester.



## 6.7 Detergents

Detergents are cleaning agents which are used to improve the cleaning properties of water. Water has a high surface tension and does not wet greased surfaces well. Water also does not dissolve grease. To be able to remove such substances using water, we need to add compounds to the water to enable it to wet and soak the clothes between the fibres, separate grease and any other dirt from the fibres and suspend the grease or dirt in the water so that it can be washed away. Any substance that has the above characteristics is called a **detergent**. Detergents are not only used in cleaning clothes, they are also applied in cleaning dishes, vehicles, walls of houses among very many other things.

There are two types of detergents:

1. Soapy detergents
2. Soapless detergents

### Soapy detergents

Soap is a mixture of the salts of medium-chain and long-chain alkanolic acids. For example, if we react an 18 carbon-chain alkanolic acid, for example **octadecanoic acid**,  $\text{CH}_3(\text{CH}_2)_{16}\text{COOH}$ , with sodium hydroxide we will get a salt (soap) and water. Generally,



We can react octadecanoic acid with sodium hydroxide to form sodium octadecanoate.

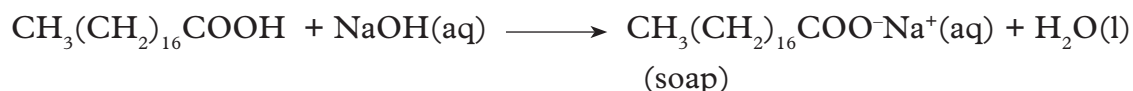

However, soaps are made by reacting esters with concentrated sodium hydroxide solution.

## Activity 6.10

Laboratory preparation of soapy detergents.

### *Apparatus and chemicals*

- 100 cm<sup>3</sup> beaker
- coconut oil, castor oil or animal fat
- sodium hydroxide solution
- sodium chloride
- retort stand and clamp
- wire gauze
- filter paper
- filter funnel
- source of heat

### *Procedure*

1. Pour about 4 cm<sup>3</sup> of castor oil or place about 40g of animal fat into 100cm<sup>3</sup> beaker.
2. Add about 15 cm<sup>3</sup> of 4M sodium hydroxide solution.
3. Boil the mixture for about 10-15 minutes stirring and adding small amounts of distilled water. The distilled water should make up for evaporation.
4. Add about four spatula full of sodium chloride and stir well.
5. Allow the mixture to cool.
6. Filter off the solid.
7. Wash the solid residue with distilled cold water.
8. Place the solid residue in a clean dry beaker.
  - What did you observe in every stage of the above procedure?
  - What can you conclude from the above observations?
  - Record your observations and conclusions in your notebook.
9. Place a small piece of the solid residue in two separate test tubes.
  - (i) In one test tube, add about 5 cm<sup>3</sup> of warm distilled water and shake well.
  - (ii) In the other test tube, add warm tap water and shake well.
    - What do you observe from each test tube? Explain your observations.
    - What do you conclude from the above observations?
    - Record your observations and conclusions in your notebook.
    - What would happen if you had added warm sea water? Explain your answer.

## The Facts

Soapy detergents are prepared by hydrolysing vegetable oil or animal fat using an alkali (concentrated sodium hydroxide solution). This reaction is an example of **saponification** reaction. Sodium chloride is added to help in precipitating the soap. It does this by reducing the solubility of the soap in a process called **salting out**.

Fats and oils are esters of long-chain alkanolic acids called **fatty acids** and **glycerol**, an alcohol with three hydroxyl ( $-\text{OH}$ ) groups. They occur naturally in plants and animals.

An example of an ester found in fats and oils is a structure as shown below. Note that the structure has '3 parts' of a long alkanolic acids numbered as 1, 2 and 3.

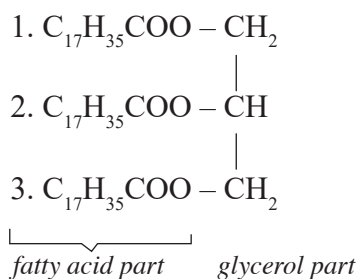

When a fat is boiled with sodium hydroxide solution, it is hydrolysed to give glycerol (propan-1,2,3-triol) and soap (sodium octadecanoate) i.e.

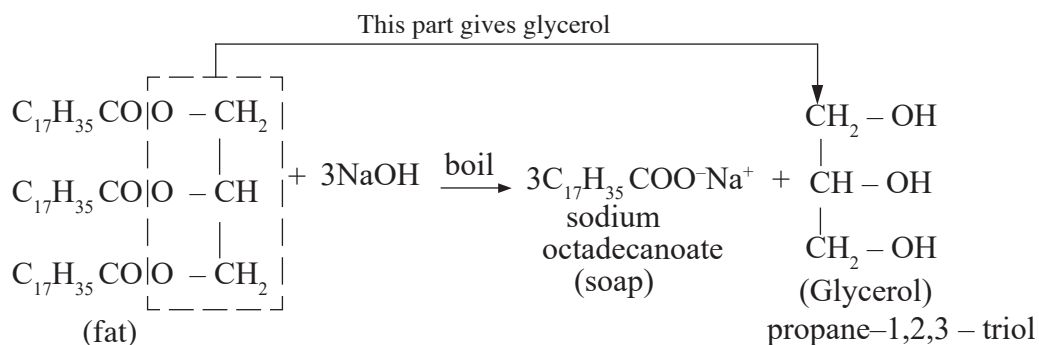

**NB:** Each part of the acid formed reacts with NaOH to form the salt i.e sodium octadecanoate ( $\text{C}_{17}\text{H}_{35}\text{COO}^- \text{Na}^+$ ) which is the soap. This is neutralisation.

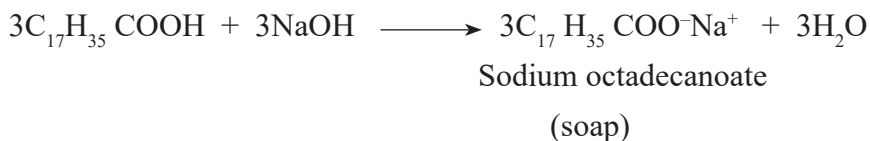

Soaps can be prepared using the general method which can be represented by the following equation:

Fat or oil + sodium hydroxide  $\longrightarrow$  soap + glycerol

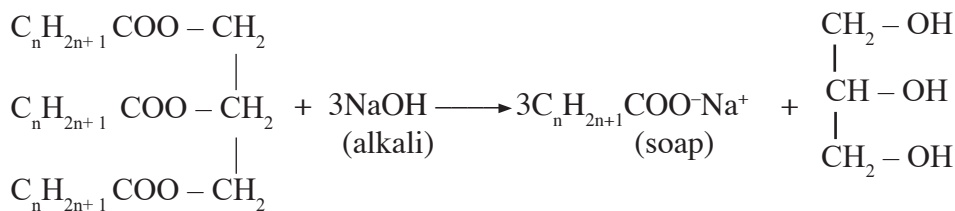

Fat or oil

Propane-1,2,3-triol  
(glycerol)

**Note** that soap is the sodium salt of the fatty acid.

The general formula for ordinary soap is  $\text{C}_n\text{H}_{2n+1}\text{COO}^-\text{Na}^+$ .

- We can summarise the process of making soap by alkaline hydrolysis in a flow chart as shown below. It involves hydrolysis, neutralization, salting and addition of perfumes or colours.

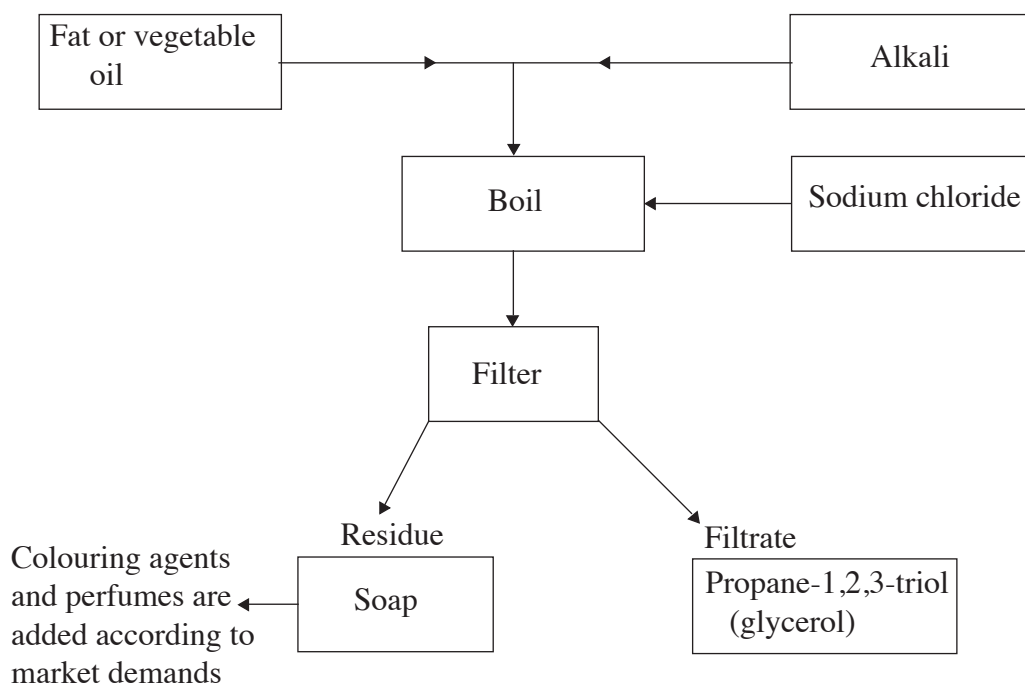

**Fig. 6.7: Flow chart for the preparation of soap**

## Check your progress 6.10

1. What is saponification reaction?
2. List the reagents required for the preparation of a soapy detergent (soap).
3. What is observed when the reagents in 2 above are added together and heated?
4. What is the purpose of adding sodium chloride when preparing soap?
5. Write a chemical equation for the formation of soap from animal fat.

### Mode of action of soapy detergents

Detergents help water to soak into clothes when they are being washed. The detergent forms a thin layer on top of the water. This layer breaks down the strong forces of attraction between water molecules on the surface.

Assume our soap has a structure as shown below.

$\text{CH}_3(\text{CH}_2)_{16}\text{COO}^-\text{Na}^+$ . We can represent this structure as  $\text{RCOO}^-\text{Na}^+$  or

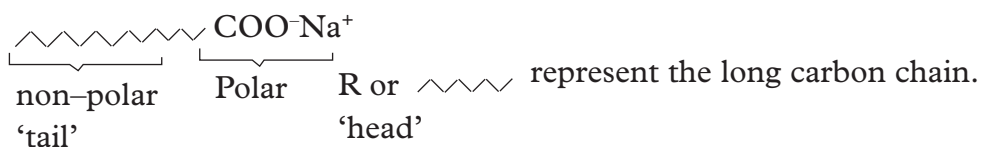

We say that detergents reduce the water surface tension. This causes the water to spread out more easily as illustrated in Fig.6.8 below

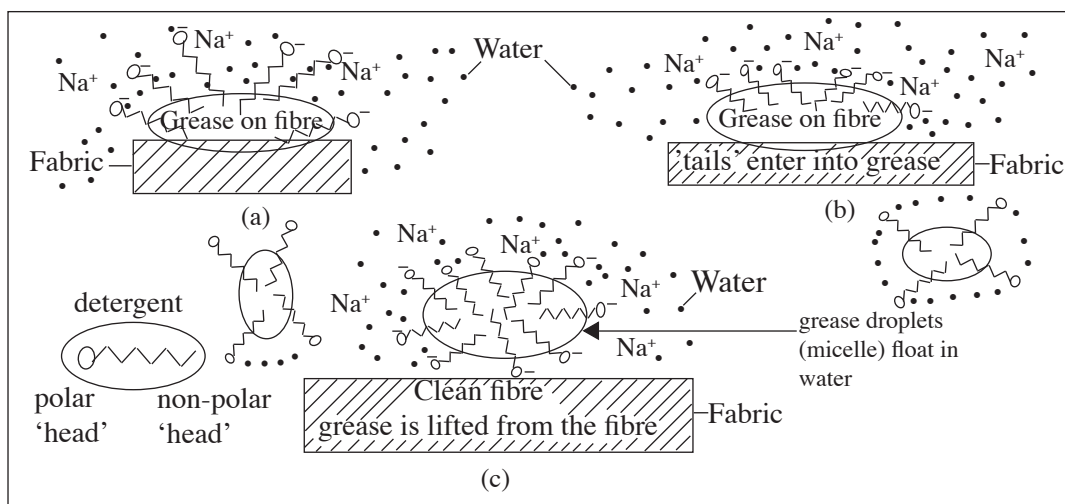

**Fig. 6.8: How soap removes grease or oil from fabrics**

1. The 'tail' of soap molecule is non-polar. We can regard it as a grease-loving end hence gets attracted by grease. The 'head' of the soap molecule is polar. It is attracted by water molecules.
  - When we are washing, soap molecules dissociate in water. The long non-polar hydrocarbon chain ('tail') of the soap molecule dissolves in grease or oil. The polar end ('head') of the molecule is attracted by water molecules.
2. When the solution is stirred or agitated, the grease is lifted from the cloth fibre and surrounded completely by soap anions as shown in Fig. 6.8(c) thereby removing the dirt from the clothes effectively.
3. Once the grease has been lifted up from the fabric by the detergent, it floats and spreads throughout the water as tiny droplets of an emulsion which makes the water cloudy. Rinsing with fresh water removes the grease emulsion. The droplets cannot mix because they repel each other due to the -vely charged anions on their surfaces.

### Pollution effect of soapy detergents

Detergents are used in everyday life in homes, industries, offices, hotels among many other places. Soapy detergents are biodegradable. This means they can be broken down by micro-organisms like bacteria in the water or in the soil. Such detergents sometimes find their way into our rivers, lakes and oceans. When bacteria decompose biodegradable detergent wastes, they use oxygen and produce carbon(IV) oxide and water. On land there is plenty of oxygen but in water, the amount of oxygen is limited. Bacteria can multiply quickly and soon oxygen levels decrease. Low oxygen levels in water have an adverse effect on aquatic animals (e.g. fish) and plants. These aquatic animals move to another area or die.

### Water hardness and soapy detergents

Water hardness is caused by presence of  $\text{Ca}^{2+}$  and  $\text{Mg}^{2+}$  ions in water.

#### Activity 6.11

*To investigate the effect of water hardness on soapy detergents*

#### **Apparatus and chemicals**

- test tubes
- sea water (if available)
- calcium sulphate or magnesium sulphate
- distilled water
- soapy detergent (soap)
- dropper

### **Procedure**

1. Place about 15-20 cm<sup>3</sup> of distilled water in a test tube.
2. To another test tube, place 15-20 cm<sup>3</sup> of sea water. In the absence of sea water, dissolve 1/2 spatula of calcium sulphate in about 15-20 cm<sup>3</sup> of water.
3. To each test tube, add about 3-4 drops of soapy detergent.
4. Shake the mixture well
  - What do you observe?
  - Record your observations and conclusions in your notebook.
  - What do you conclude from the above observations?
  - Explain your observations and conclusions from the above experiment.

From experiment 6.11, you have observed that it was difficult for soap to produce lather in the test tube with sea water or the water with dissolved calcium sulphate. You must have seen bits of white scum floating in the water or on the sides of the container when you used soapy detergent.

Many compounds dissolve in water without any chemical change but have a lot of consequences. Some of these dissolved substances make the water hard. This means that the water does not readily form a good lather with soap and causes formation of scum. Distilled water or pure water contains no dissolved solid impurities and lathers easily with soap.

Hard water is caused by dissolved magnesium and calcium hydrogencarbonates and calcium and magnesium sulphates. The hard water is formed when natural waters flow through rocks containing calcium and magnesium compounds. For example:

- chalk or limestone which contains mainly calcium carbonate CaCO<sub>3</sub>.
- or gypsum rock deposits which are mainly calcium sulphate (CaSO<sub>4</sub>) and magnesium salt mainly magnesium sulphate (MgSO<sub>4</sub>·7H<sub>2</sub>O).

These calcium and magnesium salts are washed out of rock formations. They then dissolve in acid rain forming the compounds which cause hardness in water.

We have learnt about two types of hardness in water namely:

#### **1. Temporary hardness**

#### **2. Permanent hardness**

Temporary hardness is caused by dissolved calcium hydrogencarbonate and magnesium hydrogencarbonate and permanent hardness is caused by dissolved calcium sulphate and magnesium sulphate. Hard water forms scum from the dissolved calcium and magnesium compounds. The scum is a precipitate formed when calcium and magnesium ions react with soap. After using more soap than

would otherwise be required, lather does form when all the calcium and magnesium ions have been precipitated. For example

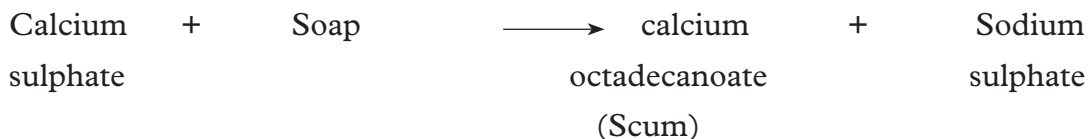

Ionic equation

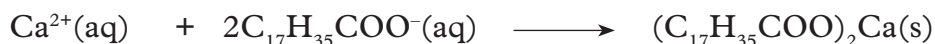

Magnesium ions are precipitated in the same way.

Using hard water can increase costs because more soap is needed. However, hard water can be made soft by removing the dissolved calcium and magnesium ions.

1. If it is due to hydrogencarbonates, it is removed by boiling.

The following experiment was done by some students in a certain school.

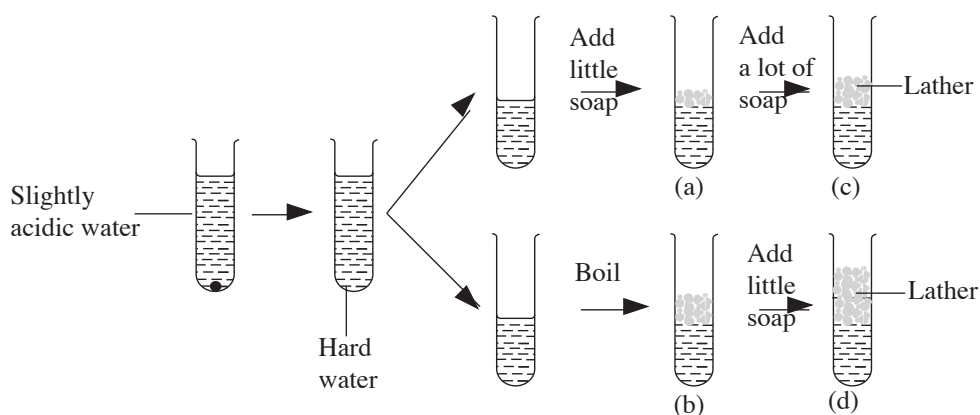

**Fig. 6.9: Effect of hard water on soapy detergent**

- (i) What do you expect to observe in test tube (a) and (b). Explain.
  - (ii) Predict observations made in (c) and (d). Explain your observations.
  - (iii) What conclusions can you make from these observations?
2. Temporary hard water caused by calcium hydrogencarbonate can be removed by boiling.
  3. On addition of sodium carbonate as washing-soda crystals it dissolves and precipitates out the calcium and magnesium ions as insoluble carbonates.
  4. The hardness of water can also be removed by an ion exchange column. Ion exchange polymer resin columns hold sodium ions. These ions can be replaced by calcium and magnesium ions when hard water passes down the column. Sodium ions do not make water hard.



**Note:** Permanent water hardness cannot be removed by boiling while temporary hardness can be removed by boiling.

### Work to Do

1. If the water in your home is hard, how can that affect the cleaning of your clothes?
2. How can you remove or decrease the hardness of water so that the soap can be effective?

## Soapless detergents

Because of the problems associated with soapy detergents e.g not lathering easily in hard water, chemists have made molecules which have similar structures, but improving some of their characteristics to produce better cleaning agents. Such agents are called **soapless detergents**. Unlike soapy detergents, they do not form scum with hard water. Soapless detergents are made from by-products of crude oil distillation.

### Activity 6.12

*Preparation of soapless detergents.*

#### **Apparatus and chemicals**

- teat pipette
- beaker
- stirring rod
- concentrated sulphuric acid
- olive oil
- 6M sodium hydroxide
- tap water/any other hard water, e.g. sea water
- distilled water

#### **Procedure**

1. Place about 15 cm<sup>3</sup> of olive oil in a beaker.
2. Place the content of the beaker in ice cold water.
3. Stir the content with glass rod as you carefully add concentrated sulphuric acid drop by drop using a dropper.
4. When the yellow oil turns brown, stop adding the acid.

5. Add about 25 cm<sup>3</sup> of 6M sodium hydroxide solution.

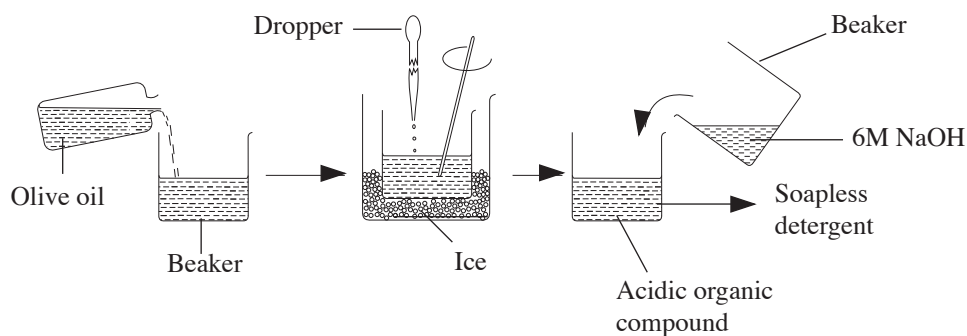

**Fig. 6.10: Preparation of soapless detergent**

6. Place about 5 cm<sup>3</sup> of the product into two separate test tubes.

- (i) To one of the test tubes, add distilled water and shake well.
- (ii) To the other test tube, add tap water or sea water (or water made hard by addition of MgSO<sub>4</sub> and shake well.
  - What do you observe in (i) and (ii) above?
  - What is the purpose of adding sodium hydroxide solution?
  - What do you conclude from your observations?
  - Record all your observations and conclusions in your note book.

### The Facts

Sodium hydroxide solution is added to neutralise the excess acid during the reaction. Soapy and soapless detergents are very similar in structure despite the different methods of preparation. Both have a long hydrocarbon chain attached to an ionic group. In soapy detergents, the ionic group is  $\text{-COO}^-$  and in soapless detergents, it is  $\text{-OSO}_3^-$ .

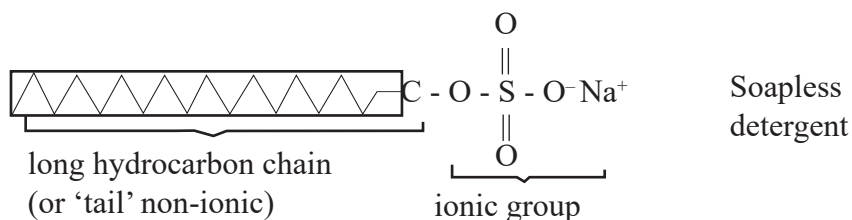
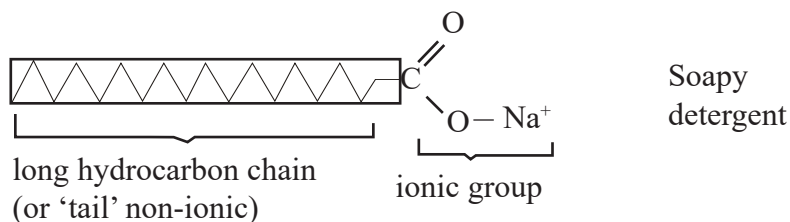

The olive oil has a double bond. Concentrated sulphuric acid adds to the double bond to form a compound called **alkyl hydrogensulphate**. This alkyl hydrogensulphate then reacts with sodium hydroxide to form a sodium alkyl sulphate which is the soapless detergent. This reaction is comparable to the reaction of ethene with sulphuric acid. When ethene is reacted with concentrated sulphuric acid, it forms ethyl hydrogensulphate.

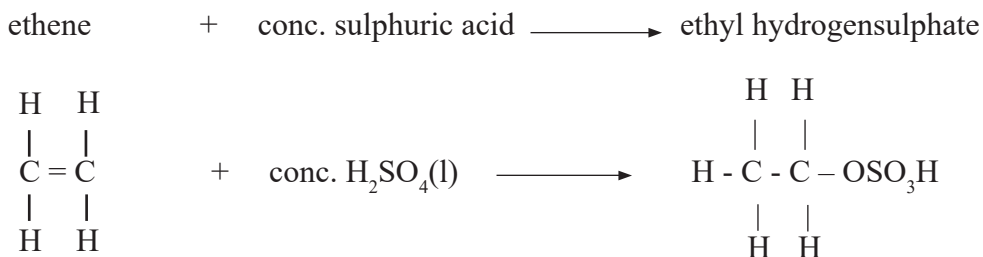

The above product is then neutralised by the sodium hydroxide solution, the hydrogen in hydrogensulphate is replaced by a sodium atom to form sodium ethylsulphate.

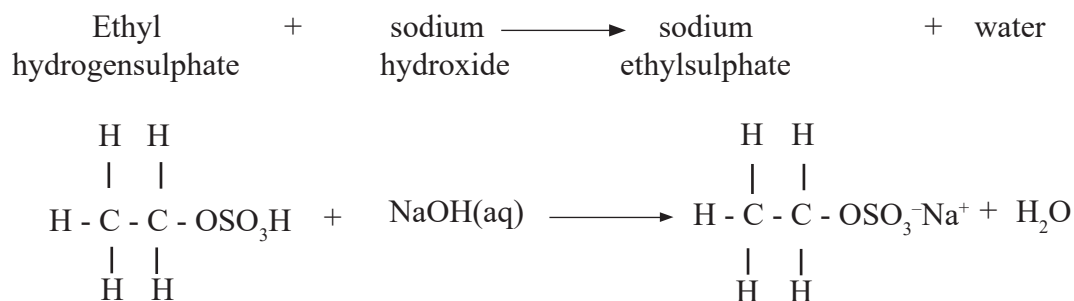

The sodium ethylsulphate is equivalent to the soapless detergent.

- Ethyl hydrogensulphate can also be made from alcohols. Let us consider the following familiar reaction of ethanol and sulphuric acid to form ethyl hydrogensulphate.

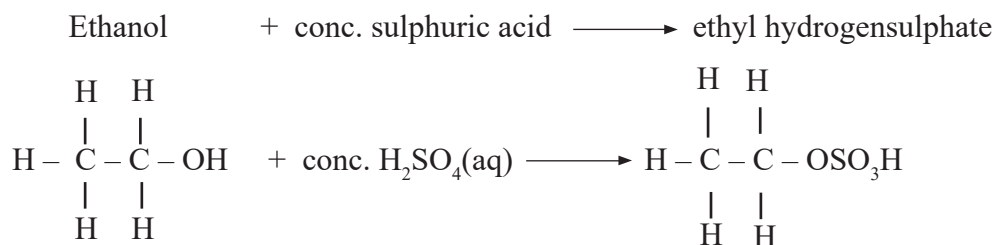

When the ethyl hydrogensulphate is neutralised by sodium hydroxide, sodium ethyl sulphate is formed

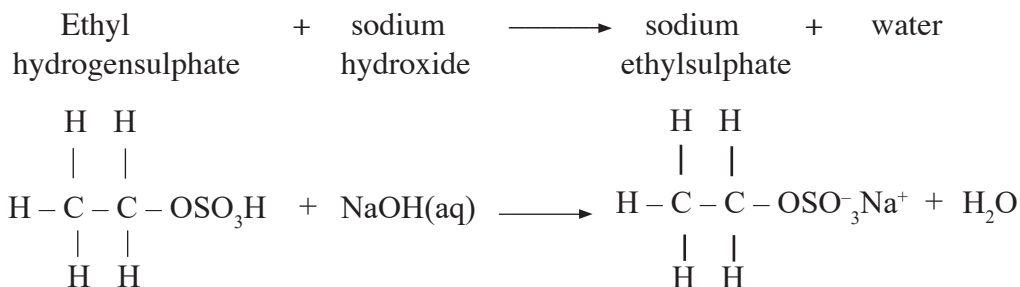

### Industrial manufacture of soapless detergent

The principles that we have discussed above are used in the manufacture of soapless detergents. Alcohols of long chain hydrocarbons of 12 to 18 carbon atoms are used. They are reacted with sulphuric acid to form alkyl hydrogensulphate.

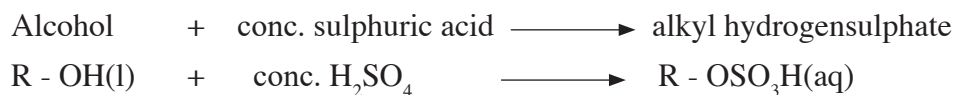

R-represents an alkyl group.

The alkyl hydrogensulphate is then neutralised by sodium hydroxide to form sodium alkylsulphate which is the soapless detergent we require.

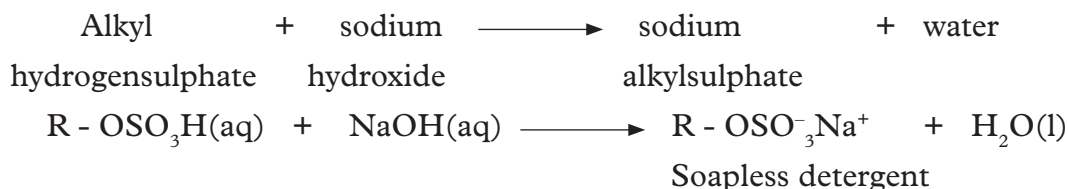

The actual structure of the part of a soapless detergent represented by R can be a complex as shown in the following soapless detergent.

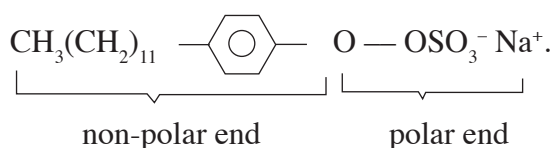

**Note** that the polar end of a soapless detergent has  $\text{OSO}_3^-$  group while that of a soapy detergent has  $-\text{COO}^-$  group.

Can you name some soapless detergents you use?

## Work to Do

1. Write an equation for the preparation of soapless detergents?
2. What is the difference between soapy and soapless detergents?
3. What is the effect of hard water on soapless detergents?

## Mode of action of soapless detergents

The mode of action of soapless detergents is the same as that of a soapy detergent. The hydrocarbon tail which is grease-loving will dissolve in fats, grease or oil while the ionic head which is water-loving dissolves readily in water.

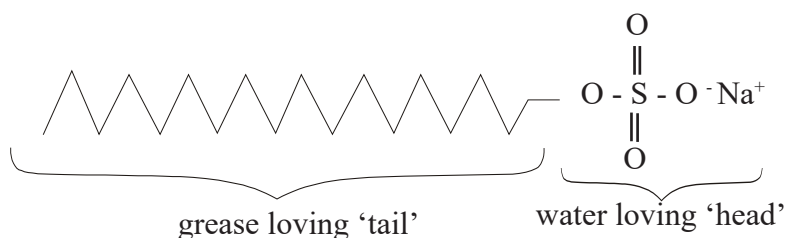

The tails of molecules of detergents stick into the greasy dirt and attraction between water molecules and the detergent molecules lifts the dirt from the fibre as illustrated above. Agitation of the solution helps to lift the dirt. The grease is then suspended in the solution with repulsive forces between detergent anions, preventing grease from returning to the material. Grease spreads through the water as tiny droplets. This is an emulsion and makes water look cloudy. On rinsing, the emulsion is washed away.

**Note:** Whereas soap forms scum with calcium and magnesium ions in hard water, soapless detergents do not.

## Pollution effects of soapless detergents

Soapless detergents have very serious effects on the environment. They are not **biodegradable** like the soapy detergents, that is, they are not broken down into harmless chemicals by the micro-organisms. They, therefore, tend to persist in water, sewage treatment and cause foaming in rivers and streams.

## Advantages of soapless detergents over soapy detergents

- They do not form scum with hard water.
- They are made from petroleum products, hence save animal fats and vegetable oils to be used for human consumption.

## Disadvantages

Soapless detergents are non-biodegradable, hence pollute the environment.

## Check your progress 6.6

1. Differentiate between soapy detergents and soapless detergents.
2. When hard water is used in cleaning, it forms a lot of scum with soap.
  - (a) With the help of equations, explain how temporary hard water is formed.
  - (b) What is scum? Explain using equations how it is formed.
  - (c) Detergents are needed to make things clean when washing with water. With the help of an illustration, explain how a detergent cleans.
3.
  - (a) What is water pollution?
  - (b) When is water said to be polluted?
  - (c) How do detergents cause water pollution?
  - (d) What are the effects of water pollution caused by detergents?

## 6.8 Polymers and fibres

Polymers and fibres are giant molecules. Polymers vary in strength and flexibility. Polymers which do not stretch readily are suitable for use as fibres. They occur naturally or may be made artificially in industries by joining small units, called **monomers**. The process by which they are formed is called **polymerisation**. Polymers and fibres can be classified into two groups.

- (a) Natural polymers and fibres.
- (b) Synthetic polymers and fibres.

### Natural polymers and fibres

All living things contain polymers. Proteins, carbohydrates, wood and natural rubber are all polymers. These polymers are formed in nature i.e. they are not man-made polymers. Examples of some natural polymers/fibres are:

- Starch
- Cellulose e.g. cotton, wool, paper, silk.
- Proteins
- Glycogen
- Fats
- Rubber

### Synthetic polymers and fibres

These are polymers and fibres that are man-made. They include

- Polythene
- Polychloroethene (PVC)
- Polyphenylethene (Polystyrene)
- Terylene

- Nylon
- Perspex (artificial glass)

### Work To Do

1. What is a natural polymer and fibre?
2. Name four
  - (i) natural polymers and fibres.
  - (ii) synthetic polymers and fibres.

Synthetic polymers are made by polymerisation. There are two kinds of polymerisation:

- addition polymerisation.
- condensation polymerisation.

### Addition polymerisation of some synthetic polymers

Addition polymerisation involves joining monomers, which are unsaturated molecules like ethene, chloroethene and phenylethene etc. During polymerisation of **ethene** for example, the double bonds between the carbon atoms are broken down enabling many molecules of ethene to join to each other to form a large molecule called **poly(ethene)**. It is commonly called polythene. Polythene is therefore an addition polymer. This can be summarised in the following equations.

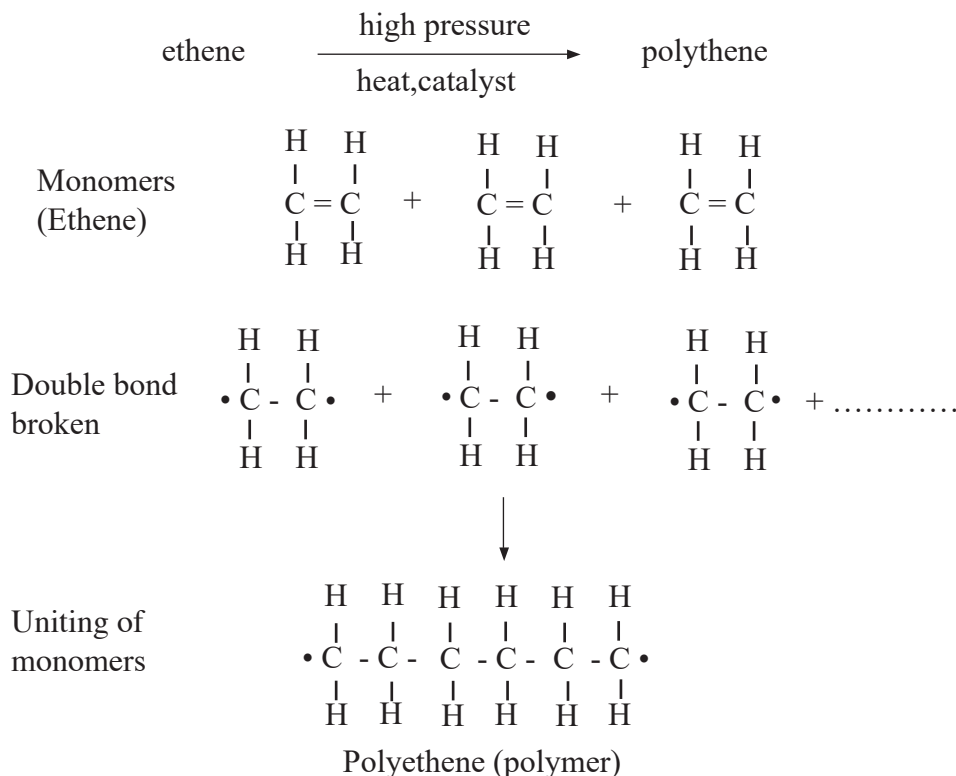

Note that at each end of the polymer, there is a lone electron indicating that more monomers can be joined to form a longer polymer. In this way, a very long chain of carbon atoms is formed. The chain may contain over 50,000 carbon atoms or less. If  $n$  molecules of ethene combine, the process can be written as.

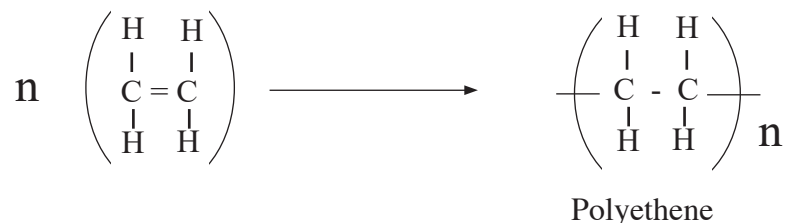

## 2. Polychloroethene (Polyvinylchloride) PVC

Polychloroethene is made from monomers called chloroethene. It is also formed by addition polymerisation.

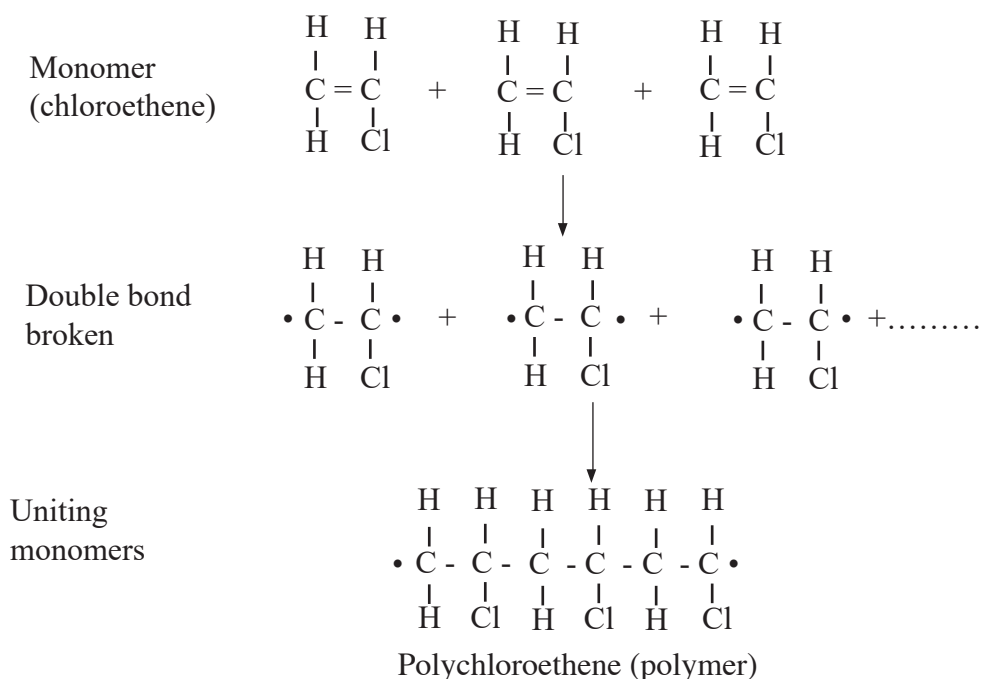

Again, if  $n$ -molecules of chloroethene combine we get;

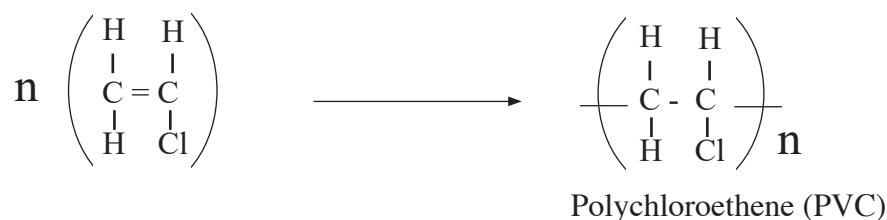



3. **Polyphenylethene** is also formed by addition polymerisation.

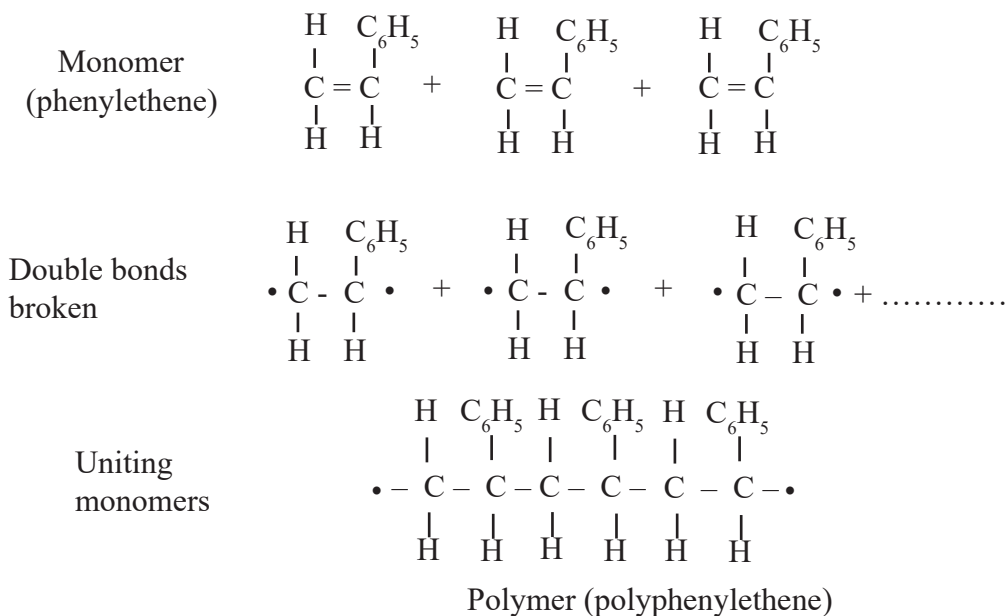

$n$ -molecules combine as follows

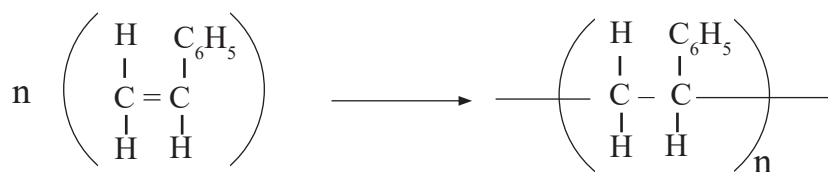

Note that  $\text{C}_6\text{H}_5$  can be represented as



Polyphenylethene  
(polystyrene)

**Table 6.13 Summary of polymers formed by addition polymerisation**

Name of polymer	Formula of monomer	Name of monomer	Reaction conditions	Part of polymer chain
Polyethene (high density form)	$  \begin{array}{c} \text{H} \quad \text{H} \\   \quad   \\ \text{C} = \text{C} \\   \quad   \\ \text{H} \quad \text{H} \end{array}  $	Ethene (gas)	Low temperature and pressure, special catalyst	$  \left( \begin{array}{c} \text{H} \quad \text{H} \quad \text{H} \quad \text{H} \\   \quad   \quad   \quad   \\ \text{C} - \text{C} - \text{C} - \text{C} \\   \quad   \quad   \quad   \\ \text{H} \quad \text{H} \quad \text{H} \quad \text{H} \end{array} \right)  $
Polychloroethene (PVC)	$  \begin{array}{c} \text{H} \quad \text{H} \\   \quad   \\ \text{C} = \text{C} \\   \quad   \\ \text{H} \quad \text{Cl} \end{array}  $	Chloroethene	60 °C, high pressure, $\text{H}_2\text{O}_2$ catalyst	$  \left( \begin{array}{c} \text{H} \quad \text{H} \quad \text{H} \quad \text{H} \\   \quad   \quad   \quad   \\ \text{C} - \text{C} - \text{C} - \text{C} \\   \quad   \quad   \quad   \\ \text{H} \quad \text{Cl} \quad \text{H} \quad \text{Cl} \end{array} \right)  $
Polyphenylethene (Polystyrene)	$  \begin{array}{c} \text{H} \quad \text{H} \\   \quad   \\ \text{C} = \text{C} \\   \quad   \\ \text{H} \quad \text{C}_6\text{H}_5 \end{array}  $	Phenylethene (styrene)	Catalyst, heat	$  \left( \begin{array}{c} \text{H} \quad \text{H} \quad \text{H} \quad \text{H} \\   \quad   \quad   \quad   \\ \text{C} - \text{C} - \text{C} - \text{C} \\   \quad   \quad   \quad   \\ \text{H} \quad \text{C}_6\text{H}_5 \quad \text{H} \quad \text{C}_6\text{H}_5 \end{array} \right)  $

## Condensation polymerisation

This is the formation of a single molecule by the combination of two or more molecules. This process usually is accompanied by elimination of a simple molecule e.g. water or hydrogen chloride. For example, if we want to join the boxes below, we can do that by giving off a simple water molecule as shown.

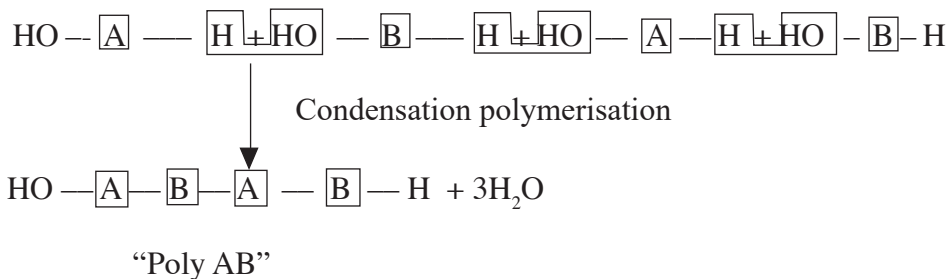

Nylon and terylene are made by condensation polymerisation.

Let us consider condensation polymerisation of nylon. Nylon is a polymer of 1,6-diaminohexane and hexane-1,6-dioyl dichloride.

The structure of 1,6-diaminohexane is

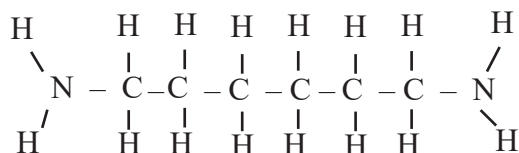

1,6-diaminohexane

which can be represented as  $\text{H} - \text{O} - \text{H}$  for simplicity while the structure of hexane-1,6-dioyl dichloride is

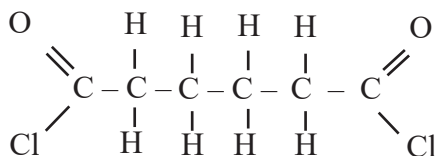

Hexane-1,6-dioyl dichloride

which we can be represented as  $\text{Cl} - \square - \text{Cl}$

When a molecule of 1,6-diaminohexane reacts with a molecule of hexane-1,6-dioyl dichloride, the two join by eliminating a hydrogen chloride molecule.



This process can occur again and again forming a long polymer which is called nylon.

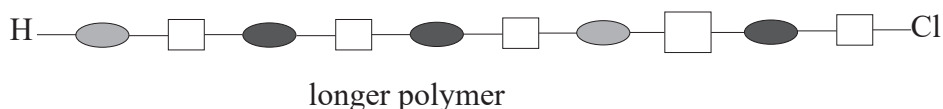

Now, let us see how nylon is polymerised using actual monomers.

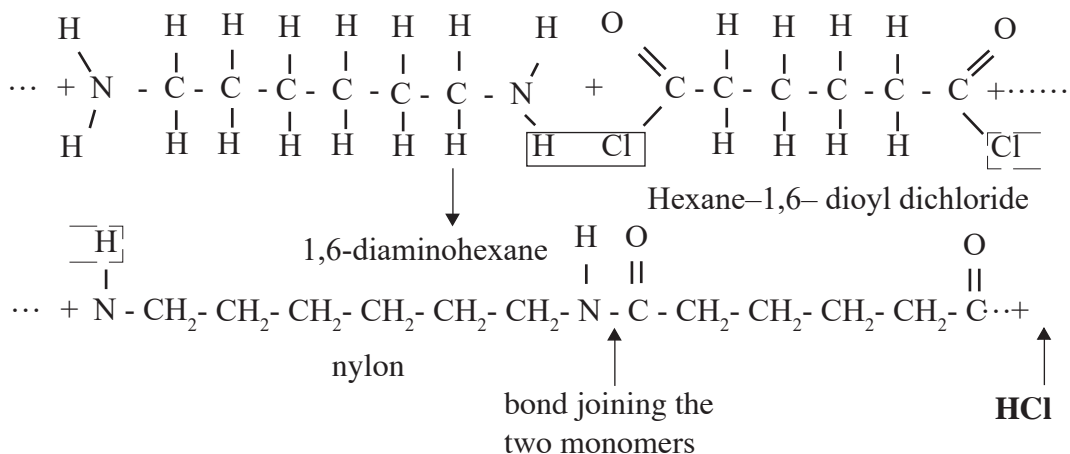

### Work To Do

1. Name two methods of preparing polymers and fibres.
2. With equations, describe the preparation of
  - (i) polyphylethene
  - (ii) nylon
3. Write equations for the formation of polystyrene from styrene.
4. Name the monomer that forms cellulose.

### Properties of synthetic polymers

Although different polymers have unique characteristics, many synthetic polymers have the following properties.

- They do not corrode in air or water.
- They are thermal insulators.
- They are electrical insulators.
- They do not decompose easily.
- They are relatively light.
- Some synthetic polymers are soft and malleable while others are very strong.
- They are cheap to produce.
- Some are transparent.

**Table 6.14 Properties and uses of specific synthetic polymers**

Name of polymer	Trade name of polymer	Properties	Uses
Polyethene	Polythene	<ul style="list-style-type: none"><li>• tough</li><li>• durable</li></ul>	Used in making <ul style="list-style-type: none"><li>• pipes and plastic bags</li><li>• bowls and bottles</li><li>• packaging material</li><li>• insulation for electric wiring</li></ul>
Polychloroethene	Polyvinyl chloride (PVC)	<ul style="list-style-type: none"><li>• tough</li><li>• durable</li></ul>	Used in making <ul style="list-style-type: none"><li>• crates and boxes</li><li>• plastic rope</li><li>• artificial leather</li><li>• water pipes</li><li>• insulation for electrical wires</li></ul>
Polyphenylethene	Polystyrene	<ul style="list-style-type: none"><li>• light</li><li>• poor conductor of heat</li></ul>	Used in making <ul style="list-style-type: none"><li>• insulation material</li><li>• packaging(foam)</li><li>• ceiling tiles</li><li>• clothes</li><li>• plastic model kits</li></ul>
Terylene	Terylene ( a polyester)	<ul style="list-style-type: none"><li>• light</li><li>• tough</li><li>• durable</li></ul>	Used in making <ul style="list-style-type: none"><li>• ropes</li><li>• clothings</li><li>• carpets</li></ul>
Nylon	Nylon	<ul style="list-style-type: none"><li>• light</li><li>• tough</li><li>• durable</li></ul>	Used in making <ul style="list-style-type: none"><li>• ropes</li><li>• clothings</li><li>• carpets</li></ul>
Perspex	Perspex	<ul style="list-style-type: none"><li>• strong</li><li>• transparent</li></ul>	Used in making <ul style="list-style-type: none"><li>• safety glass</li><li>• reflectors</li><li>• contact lenses</li><li>• false teeth</li></ul>

**Table 6.15 Summary of monomers and their respective polymers**

Monomer	Polymer	Trade Name
$  \begin{array}{c}  \text{H} \quad \text{H} \\  \diagdown \quad / \\  \text{C} = \text{C} \\  / \quad \diagdown \\  \text{H} \quad \text{H} \\  \text{Ethene}  \end{array}  $	$  \left( \begin{array}{cc}  \text{H} & \text{H} \\    &   \\  -\text{C} & - \text{C}- \\    &   \\  \text{H} & \text{H}  \end{array} \right)_n  $ <p>Poly(ethene)</p>	Polythene
$  \begin{array}{c}  \text{H} \quad \text{Cl} \\  \diagdown \quad / \\  \text{C} = \text{C} \\  / \quad \diagdown \\  \text{H} \quad \text{H} \\  \text{Chloroethene}  \end{array}  $	$  \left( \begin{array}{cc}  \text{H} & \text{Cl} \\    &   \\  -\text{C} & - \text{C}- \\    &   \\  \text{H} & \text{H}  \end{array} \right)_n  $ <p>Polychloroethene</p>	Polyvinyl chloride (PVC)
$  \begin{array}{c}  \text{H} \quad \text{C}_6\text{H}_5 \\  \diagdown \quad / \\  \text{C} = \text{C} \\  / \quad \diagdown \\  \text{H} \quad \text{H} \\  \text{Phenylethene}  \end{array}  $	$  \left( \begin{array}{cc}  \text{H} & \text{C}_6\text{H}_5 \\    &   \\  -\text{C} & - \text{C}- \\    &   \\  \text{H} & \text{H}  \end{array} \right)_n  $ <p>Polyphenylethene</p>	Polystyrene
<p>HO - CH<sub>2</sub> - CH<sub>2</sub> - OH</p> <p>Ethane-1,2-diol</p> $  \begin{array}{c}  \text{O} \quad \quad \quad \text{O} \\  // \quad \quad \quad // \\  \text{C} - \text{C}_6\text{H}_5 - \text{C} \\  / \quad \quad \quad \backslash \\  \text{OH} \quad \quad \quad \text{OH} \\  \text{benzene-1,4-dicarboxylic acid}  \end{array}  $	$  \text{---O---}\overset{\text{O}}{\parallel}\text{C---C}_6\text{H}_5\text{---}\overset{\text{O}}{\parallel}\text{C---O---CH}_2\text{---CH}_2\text{---}  $ <p>Terylene</p>	Terylene
$  \begin{array}{c}  \text{H} \quad \quad \quad \text{H} \\    \quad \quad \quad   \\  \text{H}-\text{N}-\text{CH}_2\text{CH}_2\text{CH}_2\text{CH}_2\text{CH}_2\text{CH}_2-\text{N}-\text{H} \\    \quad \quad \quad   \\  \text{H} \quad \quad \quad \text{H} \\  \text{hexane-1,6-diamine} \\  \text{and} \\  \begin{array}{c}  \text{O} \quad \quad \quad \text{O} \\  // \quad \quad \quad // \\  \text{C} \quad \text{C}_6\text{H}_4 \quad \text{C} \\  / \quad \quad \quad \backslash \\  \text{Cl} \quad \quad \quad \text{Cl} \\  \text{hexane-1,6-dioyl dichloride}  \end{array}  \end{array}  $	$  \text{--}\overset{\text{H}}{\text{N}}\text{--}(\text{CH}_2)_6\text{--}\overset{\text{H}}{\text{N}}\overset{\text{O}}{\parallel}\text{C--}(\text{CH}_2)_4\text{--}\overset{\text{O}}{\parallel}\text{C--}  $ <p>Nylon</p> <p>NB: The C and H are written as (CH<sub>2</sub>) where n is 6 or 4 as in the diagram.</p>	Nylon-6,6

Monomer	Polymer	Trade Name
$  \begin{array}{c}  \text{O} \\     \\  \text{H} \quad \quad \quad \text{C} - \text{O} - \text{CH}_3 \\  \quad \quad \quad / \\  \quad \quad \quad \text{C} = \text{C} \\  \quad \quad \quad \backslash \\  \text{H} \quad \quad \quad \text{CH}_3  \end{array}  $ <p>Methyl 2-methylpropanoate</p>	Polymethyl-2-methylpropanoate	Perspex
$  \begin{array}{c}  \text{F} \quad \quad \quad \text{F} \\  \quad \quad \quad \backslash \quad / \\  \quad \quad \quad \text{C} = \text{C} \\  \quad \quad \quad / \quad \backslash \\  \text{F} \quad \quad \quad \text{F}  \end{array}  $ <p>Tetrafluoroethene</p>	Polytetrafluoroethene	PTFE, 'Teflon'

The advantages and disadvantages of synthetic and natural polymers and fibres have been summarised in Table 6.17 and 6.18 below.

**Table 6.17 Advantages and disadvantages of synthetic polymers and fibres.**

Advantages	Disadvantages
<ul style="list-style-type: none"> <li>• They are light and therefore portable.</li> <li>• They are soft, and easy to manufacture.</li> <li>• They can be made into complicated shapes more easily i.e. are malleable.</li> <li>• They are good insulators and thermal radiators.</li> <li>• They are resistant to corrosion from acids, alkalis, water and air.</li> <li>• They are colourful and attractive.</li> <li>• They are cheap and therefore affordable.</li> </ul>	<ul style="list-style-type: none"> <li>• They have comparatively low strength.</li> <li>• They have poor heat resistance.</li> <li>• They have poor weather resistance.</li> <li>• They have low dimensional stability.</li> <li>• They are not biodegradable hence difficult to dispose.</li> <li>• Some synthetic polymers give off poisonous gases e.g. carbon(II) oxide when they are burnt.</li> <li>• They increase carbon(IV) oxide in the atmosphere when they burn. Carbon(IV) oxide causes global warming.</li> </ul>

**Table 6.18 Advantages and disadvantages of natural polymers and fibres**

Advantages	Disadvantages
<ul style="list-style-type: none"> <li>• They are biodegradable and can easily be disposed.</li> <li>• They do not burn readily.</li> <li>• Do not produce poisonous gases when they burn.</li> </ul>	<ul style="list-style-type: none"> <li>• Cannot be moulded into complicated shapes like synthetic polymers.</li> </ul>

## Rubber

You probably have seen rubber. An example of rubber is the one you use to erase while drawing. Rubbers are plastic materials which are elastic. Rubber can be natural or synthetic.

### Natural rubber

Natural rubber is a polymer of 2-methylbut-1,3-diene i.e.

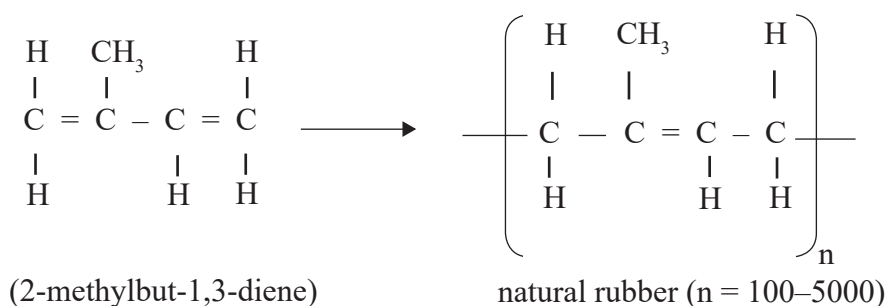

Natural rubber is obtained from rubber trees. The trees produce a milky substance called latex. Latex is a mixture of rubber and water. The latex is collected from incisions in the trunks of rubber trees then taken to the factory for processing to produce rubber. During processing, acid is used to coagulate the rubber. The solid rubber can then be made into different shapes for different uses. Pure rubber is soft and sticky. However, its physical properties can be improved or modified by heating with sulphur. The process by which rubber is heated with sulphur is known as vulcanisation of rubber. The sulphur atoms form cross-links between chains of rubber molecules decreasing the number of double bonds in the polymer. Vulcanised rubber is harder, tougher and less flexible. It also has a wide range of applications in industries.

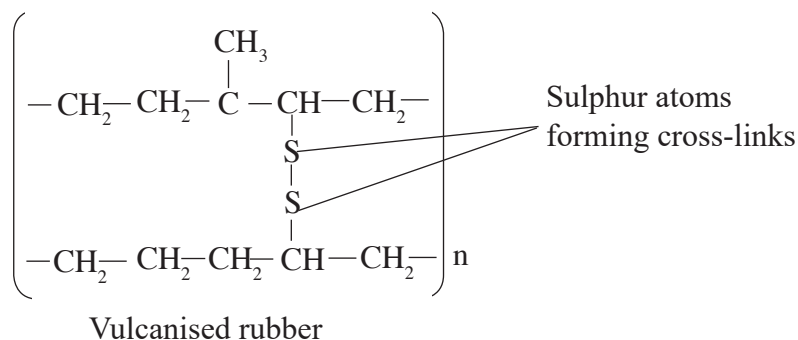

## Some uses of vulcanised rubber

Vulcanised rubber is used to make tyres, valves, shoes and for flooring. Name other uses of vulcanised rubber.

## Synthetic Rubber

Because of disadvantages associated with the physical properties of natural rubber i.e. being soft and sticky; a tougher rubber was necessary. Synthetic rubber is made in such a way that it resists action of oils, solvents and abrasion. An example of synthetic rubber is polybutadiene shown below.

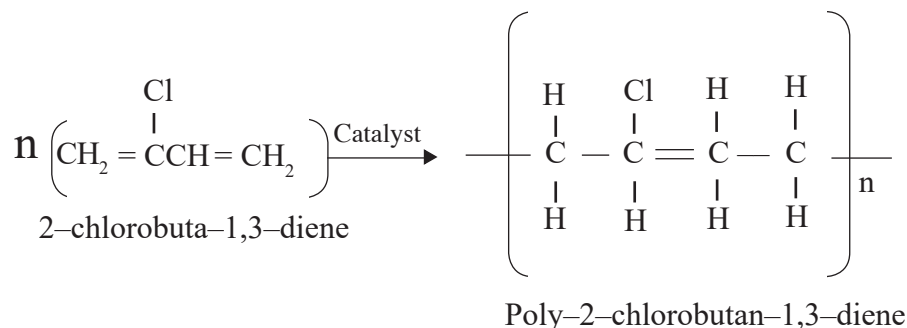

## Disposal of synthetic polymers

Plastic waste like polythene bags, drinks containers and coffee wrappers litter our environment within the cities and on the country side. Cattle and other domestic animals have been choked after swallowing plastic materials. The problem is made worse by the fact that plastic articles are non-biodegradable i.e. cannot be broken down by micro-organisms like bacteria. They do not decompose like paper, wood among other natural polymers. So, we should avoid careless disposal of these wastes.

### How then do we dispose off these wastes?

1. Dumping in holes underground.
2. Destroyed by burning.
3. Produce biodegradable plastics. Biodegradable plastic bags are already available in some parts of the world.
4. Recycling the plastics.

**Note:** The safest methods are the ones named in number 3 and 4 above.

- Explain why methods 1 and 2 above are not recommended for disposal of plastics? Plastics are non-biodegradable and will stay underground for a very long time. Burning plastics can produce toxic gases into the atmosphere and also carbon(IV) oxide which causes global warming.



## Check your progress 6.7

- How many products are formed from an
  - addition polymerisation?
  - condensation polymerisation?
- An addition polymer is made from a monomer Q shown below. Draw part of the polymer chain that forms and name the polymer.

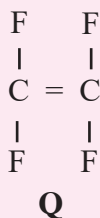

- The molecular mass of a polymer does not have a fixed value. Explain.
- Ethene is used in the manufacture of the plastic poly(ethene). Ethene is heated under high pressure in the presence of a catalyst. Many ethene molecules join together to form a giant molecule poly(ethene). The diagram below shows how the polymer is formed.

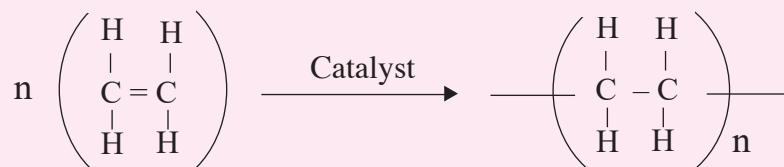

- What is the name given to this reaction?
  - Describe how ethene molecules join together to form poly(ethene).
- What environmental effects do plastics have?
  - The following are two addition polymers. Write the formulae and names for the monomers.

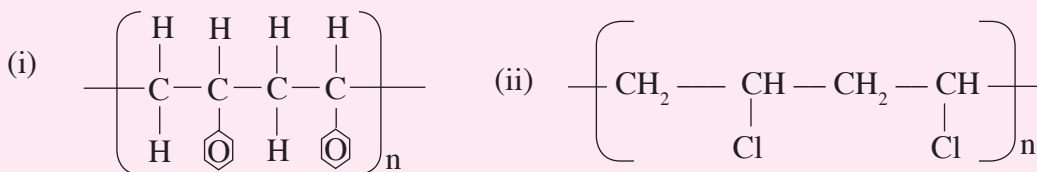

- Write an equation to represent polymerisation of 1-chloroprop-1-ene whose structure is as shown below. What is the name of the polymer formed?

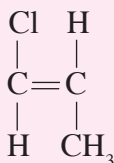

## 6.9 Alkanals and Alkanones

Alkanals and alkanones molecules are characterized by the presence of a carbonyl group. A carbonyl group consists of an oxygen atom doubly bonded to a carbon atom.  $-C=O$ .

Carbonyl group is one of the most important functional groups in organic chemistry and biochemistry due to its capability to undergo wide variety of reactions. This group is present in alkanals (also called aldehydes) and alkanones (also called ketones). The carbon atom of the carbonyl group must be connected to two other atoms or groups.

The general formula of alkanal is  $C_nH_{2n}O$ .

### Alkanals

The general formula of alkanals is  $RCHO$ . Where R represents an alkyl group e.g.  $CH_3-$ ,  $CH_3CH_2-$ ,  $CH_3CH_2CH_2-$  except in methanal. In methanal, R represents hydrogen (H).

### Nomenclature of Alkanals

The name of the alkanal is derived from the parent alkane with same number of carbon atoms. Then the suffix ‘-e’ from the parent alkane is replaced by suffix ‘-al’.

The longest continuous carbon chain is numbered such that the carbon which is in the carbonyl group is always number 1.

Table 6.19: Names, formulae and structures of the first five alkanals

Name	Condensed formula	Structural formulae	Molecular formulae
Methanal	HCHO	$\begin{array}{c} O \\    \\ H-C-H \end{array}$	HCHO
Ethanal	$CH_3CHO$	$\begin{array}{c} H & O \\   &    \\ H-C-C-H \\   \\ H \end{array}$	$CH_3CHO$
Propanal	$CH_3CH_2CHO$	$\begin{array}{c} H & H & O \\   &   &    \\ H-C-C-C-H \\   &   \\ H & H \end{array}$	$C_2H_5CHO$
Butanal	$CH_3CH_2CH_2CHO$	$\begin{array}{c} H & H & H & O \\   &   &   &    \\ H-C-C-C-C-H \\   &   &   \\ H & H & H \end{array}$	$C_3H_7CHO$
Pentanal	$CH_3CH_2CH_2CH_2CHO$	$\begin{array}{c} H & H & H & H & O \\   &   &   &   &    \\ H-C-C-C-C-C-H \\   &   &   &   \\ H & H & H & H \end{array}$	$C_4H_9CHO$

## Alkanones

The general formula of alkanones is  $\text{R}-\overset{\text{O}}{\parallel}{\text{C}}-\text{R}'$ , where R and R' are alkyl groups that have the same or different numbers of carbon atoms.

### Nomenclature of alkanones

The parent name of the alkanones is derived from corresponding alkane with similar number of carbon atom. The suffix '-e' from the parent alkane is replaced by the suffix '-one'. The numbering of the carbon atoms of alkanones begins at the end nearer to the carbonyl group. For example,  $\text{CH}_3\text{CH}_2\text{CH}_2\text{CO}_2\text{CH}_3$  Pentan-2-one

For alkanones with five or more carbon atoms, the number of the carbon attached to the carbonyl group is given.

Table 6.20 Names, formulae and structures of the first four alkanones

Name	Condensed formulae	Structural formulae	Molecular formulae
Propanone	$\text{CH}_3\text{COCH}_3$	$\begin{array}{c} \text{H} \quad \text{O} \quad \text{H} \\   \quad    \quad   \\ \text{H}-\text{C}-\text{C}-\text{C}-\text{H} \\   \quad   \\ \text{H} \quad \text{H} \end{array}$	$\text{C}_3\text{H}_6\text{O}$
Butanone	$\text{CH}_3\text{CH}_2\text{COCH}_3$	$\begin{array}{c} \text{H} \quad \text{H} \quad \text{O} \quad \text{H} \\   \quad   \quad    \quad   \\ \text{H}-\text{C}-\text{C}-\text{C}-\text{C}-\text{H} \\   \quad   \quad   \\ \text{H} \quad \text{H} \quad \text{H} \end{array}$	$\text{C}_4\text{H}_8\text{O}$
Pentan-2-one	$\text{CH}_3\text{CH}_2\text{CH}_2\text{COCH}_3$	$\begin{array}{c} \text{H} \quad \text{H} \quad \text{H} \quad \text{O} \quad \text{H} \\   \quad   \quad   \quad    \quad   \\ \text{H}-\text{C}-\text{C}-\text{C}-\text{C}-\text{C}-\text{H} \\   \quad   \quad   \quad   \\ \text{H} \quad \text{H} \quad \text{H} \quad \text{H} \end{array}$	$\text{C}_5\text{H}_{10}\text{O}$
Penta-3-one	$\text{CH}_3\text{CH}_2\text{COCH}_2\text{CH}_3$	$\begin{array}{c} \text{H} \quad \text{H} \quad \text{O} \quad \text{H} \quad \text{H} \\   \quad   \quad    \quad   \quad   \\ \text{H}-\text{C}-\text{C}-\text{C}-\text{C}-\text{C}-\text{H} \\   \quad   \quad   \quad   \\ \text{H} \quad \text{H} \quad \text{H} \quad \text{H} \end{array}$	$\text{C}_5\text{H}_{10}\text{O}$

## Structural differences between alkanals and alkanones

### Alkanals

Alkanals have alkyl carbon chains (R-) attached to the carbonyl functional group ( $\overset{\text{O}}{\parallel}{\text{C}}-\text{H}$ ), except in the case of methanal (the first member of the group) where the hydrogen atom attaches to the functional group to form methanal ( $\text{H}-\overset{\text{O}}{\parallel}{\text{C}}-\text{H}$ ).

The functional group in alkanals is always at the end of the carbon chain.

### Alkanones

Alkanones have a carbonyl group ( $\overset{\text{O}}{\parallel}{\text{C}}$ ) between two alkyl groups (R and R') written as  $\text{R}-\overset{\text{O}}{\parallel}{\text{C}}-\text{R}'$ . The alkyl groups on either side of a carbonyl group, R and R', may not necessarily have equal number of carbon atoms.

## Sources of alkanals and alkanones

### Sources of alkanals

- Traces of alkanals are found in essential oils which often contribute to their favourable odours.
- Most sugars are derivatives of alkanals.
- Traces of methanal are present in the air. This is as a result of photochemical oxidation of hydrocarbons.
- Oxidation of primary alcohols under controlled conditions.

### Sources of alkanones

- Alkanones are by-products obtained when body fat provides energy instead of glucose.
- Alkanones are also obtained from the oxidation of secondary alcohols under controlled conditions.

### (a) Oxidation of primary alkanols to form alkanals

#### Activity 6.13

**Aim:** To oxidise primary alkanols to form alkanal

#### Requirements

- Test tube
- Acidified potassium manganate (VII)
- Source of heat
- Ethanol

#### Procedure

1. Put about 2-3 cm<sup>3</sup> of ethanol into a test tube.
2. Add about 5 cm<sup>3</sup> of acidified potassium manganate (VII) into the test tube.
3. Warm gently.
4. Note and record your observation.

### Discussion

When acidified potassium manganate (VII) is added to ethanol, the purple colour changes to colourless. When the mixture was gently heated an “apple” smelling ethanal forms. Because it is difficult to control the amount of heat, the ethanal formed may easily get oxidized to produce ethanoic acid.

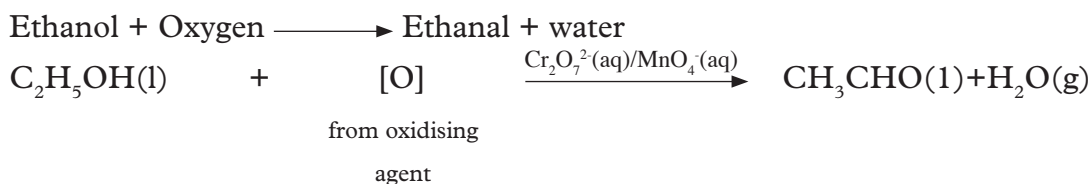

In this experiment potassium manganate(VII) is used as **oxidizing agent**. Potassium dichromate (VI) can also be in place of potassium manganate (VII).

### (b) Oxidation of secondary alcohols (alkanol) to form alkanones

When secondary alcohols are oxidized using powerful oxidizing agents such as potassium manganate (VII) and potassium dichromate (VII) they form alkanones.

For example;

Oxidation of propan – 2 – ol by acidified potassium dichromate (VI) produces propanone.

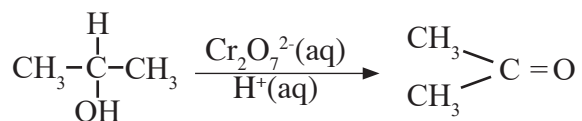

Propan – 2- ol

(secondary alkanol)

Propanone

(alkanone)

**Note:** Alkanones are not easily oxidized, so even prolonged refluxing will not produce anything else. Heating under reflux means increasing the temperature of an organic reaction to boiling without losing volatile solvents, reactants or products. Any vapourised compounds are cooled, condense and drip back into the reaction mixture.

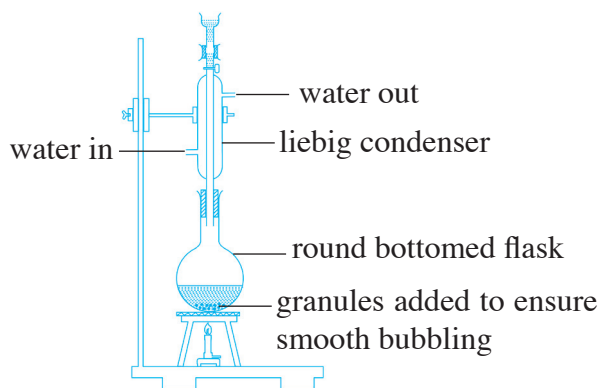

**Fig 6.11: Reflux apparatus**

### Physical properties of alkanals

The general physical properties of alkanals are as shown in table 6.21.

**Table 6.21: Trends in physical properties of alkanals**

Name	R.M.M	Melting point, °C	Boiling point °C	Density g/cm <sup>3</sup>	Solubility in water	Physical state
Methanal	30	-92	-19	0.8153	Very soluble	Gas
Ethanal	44	-124	2	0.7840	Very soluble	Liquid
Propanal	58	-81	49	0.8050	Soluble	Liquid
Butanal	72	-99	76	0.8020	Soluble	Liquid
pentanal	86	-60	103	0.8095	Slightly soluble	Liquid

- (i) All alkanals are liquid except methanal which is a gas.
- (ii) Alkanals are colourless and have a characteristic smell.
- (iii) Alkanals solubility decreases down the homologous series.

The carbonyl group (C = O) is polar, thus the starting members of the homologous series (alkanals with less than 5 atoms) are appreciably soluble in water. They even dissolve both polar and non polar solutes. However, alkanals do not have ability to form hydrogen bonds like alcohols. Alkanals are also soluble in organic solvents. The carbonyl group has less effect on the intermolecular forces than the (OH) hydroxyl group because the hydroxyl group is able to participate in hydrogen bonding.

**Note:** that the bonds between carbonyl oxygen and water cause alkanals to have a higher level of water solubility than with hydrocarbons. But the degree of solubility in water decreases with increasing molecular weight.

- (iv) The melting and boiling points of alkanals generally increase with increase in relative molecular mass. As the molecular mass increase the intermolecular forces of attraction between molecules increase. As these forces increase, more energy is required to overcome them. The carbonyl group influences the physical properties, for example ethanal (CH<sub>3</sub>CHO) with a boiling point of 20°C is a liquid at room temperature while propane with a similar relative molecular mass is a gas at room temperature and with a boiling point of -42°C. However, the boiling points of alkanals are generally lower than those of alkanols from which they are derived.

### Physical properties of ethanal

- Ethanal is a colourless liquid.
- Has a pungent fruity apple odour.
- Soluble in water.
- Has a low boiling point of 20°C.

### Chemical properties of Alkanals

Alkanals form a homologous series with similar chemical properties. The chemical properties of ethanal we shall study applies also to other alkanals.

**Table 6.22: Investigating some of the chemical properties of ethanal**

Procedure	Observation	Conclusion
1. Place a few drops of ethanal into a bottle top and ignite.		
2. Place about 2 -3 cm <sup>3</sup> of ethanal in a test tube. Test with blue and red litmus papers.		
3. Place about 2-3 cm <sup>3</sup> of ethanal in a test tube. Add about 5 cm <sup>3</sup> of acidified potassium manganate (VII) into the test tube and warm gently.		
4. Repeat step 3 but add acidified potassium dichromate VI.		
5. Place 2-3 cm <sup>3</sup> of ethanol in a test tube. Add 3 cm <sup>3</sup> of 2, 4 – dinitrophenyl hydrazine reagent.		
6. Place 2 – 3 cm <sup>3</sup> of ethanol in a test tube. Add 2 – 3 cm <sup>3</sup> of Tollen’s reagent and warm gently.		

### 1. Combustion of ethanal

When ethanal is ignited in plentiful supply of air or oxygen, it burns with a blue flame to produce carbon dioxide and water.



Ethanal + Oxygen  $\longrightarrow$  Carbon dioxide + Water

### 2. Effect on litmus

Ethanal is a neutral substance. It has no effect on both red and blue litmus papers.

### 3. Oxidation of ethanal

When acidified potassium manganate (VII) is added to ethanal, the colour changes from purple to colourless. When acidified potassium dichromate(VI) is added to ethanal the colour changes from orange to green. Potassium dichromate (VI) and potassium manganate (VII) are oxidizing agents. They oxidize ethanal to ethanoic acid.

Ethanal + Oxygen  $\xrightarrow{\text{Cr}_2\text{O}_7^{2-}(\text{aq})/\text{MnO}_4^{-}(\text{aq})}$  Ethanoic acid

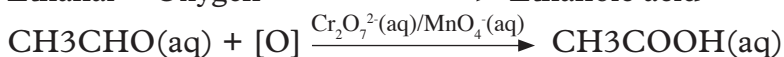

#### 4. Addition reaction

- a) Ethanal can undergo addition reaction with hydrogen cyanide (HCN) to form 2-hydroxypropanonitrile. HCN adds across the carbonyl double bond (C=O) of the ethanal molecule.

Ethanal + Hydrogen cyanide  $\longrightarrow$  2-hydroxypropanonitrile



- b) Ethanal undergoes addition reaction when shaken with saturated solution of sodium hydrogensulphite (NaHSO<sub>3</sub>).

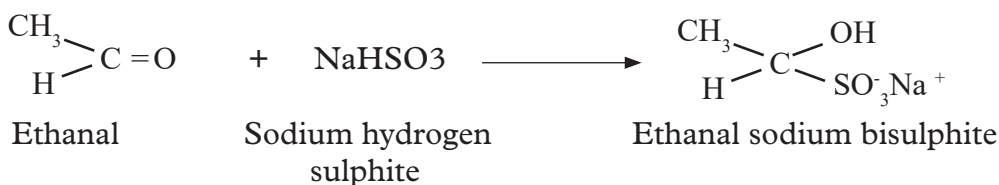

#### 5. Reduction reaction

Alkanal can also undergo addition reaction with hydrogen in presence of nickel metal catalyst or platinum metal catalyst to form primary alcohols.

Ethanal + Hydrogen  $\xrightarrow{\text{Ni catalyst}}$  Ethanol

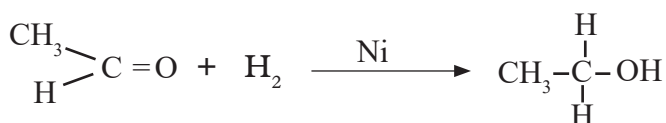

**Note:** Addition of hydrogen to a substance is called **reduction**.

#### 6. Polymerization

Alkanals can be readily converted to a variety of addition polymers just like alkenes.

##### Test for alkanals

###### a) Brady test

This is a test used to detect the presence of a carbonyl functional group in a compound using 2,4-DNPH reagent (2,4-Dinitrophenyl hydrazine). The reagent is an orange powder. Formation of a yellow precipitate shows a positive identification of a carbonyl group.

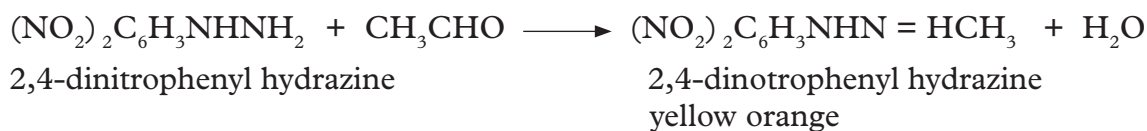

###### b) Tollen's test

Tollens reagent is a mixture of excess ammonia solution and silver nitrate solution.

Tollens reagent oxidises ethanal to ethanoic acid while the silver ions present in the



tollens reagent are reduced to silver element, forming a silver mirror on the inside of the test tube. A tollens test will follow a brady test to distinguish alkanal from alkanone.

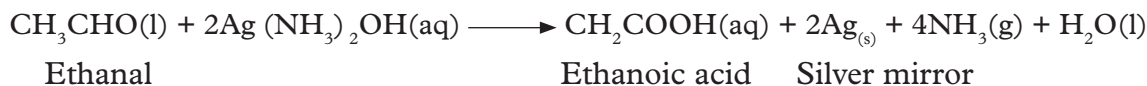

### c) Fehling's test or Benedicts solution

Fehlings solutions when mixed with ethanal change colour from blue to green to orange precipitate and then red precipitate (copper mirror). The ethanal forms ethanoic acid. A Fehling test would also be used to distinguish between alkanal and alkanone. Fehling's test give positive test with alkanals and sugars which are easily oxidized. Alkanone will not produce a red precipitate with fehling's test, the blue solution colour remains unchanged. Fehling's reagent contain copper ions under basic conditions. The copper ions are in the +2 oxidation state, and can be reduced to the + 1 oxidation state, where they form red precipitate of  $\text{Cu}_2\text{O}$  in a basic solution.

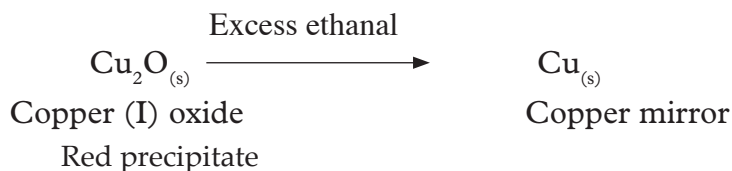
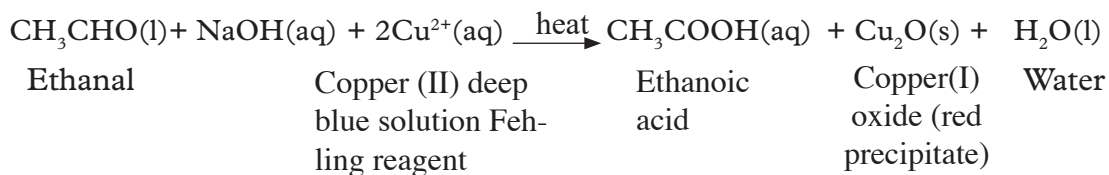

### Uses of ethanal

1. It is a raw material in production of cellulose acetates, ethylacetate and ethanoic acid.
2. It is used as a reducing agent in mirror production.
3. Used as a solvent in the rubber tanning and paper industries.
4. Used as a denaturant for alcohol.
5. Used in fuel composition.
6. Used in manufacture of perfumes.
7. Used in manufacture of plastics and synthetic rubber.
8. Formalin contains 40% methanal aqueous solution and thus used as a preservative.

## Physical properties of Alkanones

Table 6.23: Trends in physical properties of alkanones

Name	RMM	Melting point/ °C	Boiling/ Point °C	Density g/cm <sup>3</sup>	Physical state	Solubility in water
Propanone	58	-96°C	56	0.7840	Liquid	Miscible in all proportions
Butanone	72	-87°C	80	0.8050	Liquid	Very soluble
Pentan-2-one	86	-78°C	101	0.8080	Liquid	Very soluble
Hexan – 2-one	100	55°C	128	0.8113	Liquid	Soluble
Pentan-3-one	86	40°C	102	0.8150	Liquid	Soluble

- (i) All alkanones are liquids.
- (ii) Alkanones are polar because of the carbonyl group.
- (iii) Solubility of alkanes decreases down the homologous series.

Smaller alkanones are typically more soluble in water because of the ability to accept hydrogen bonds. Propanone is a good solvent and has a high miscibility with water due to the oxygen atom being able to form hydrogen bonds with water molecules.

Because alkanones are generally not hydrogen – bond donors or acceptors, they tend not to “self associate” and therefore are more volatile than alcohols and carboxylic acids (alkanoic acids) of similar molecular mass.

- (iv) Alkanones’ boiling and melting points increase with increasing molecular mass. The boiling points of alkanones are higher than that of parent corresponding alkanes. For examples butane (RMM 58) has a boiling point of 0°C while propanone (RMM 60) has a boiling point of 56°C. The difference in boiling points are due to differences in polarity and hydrogen-bonding ability. Most alkanones are polar but not extremely polar. They are good solvents for organic reactions.

### Physical properties of propanones

- (i) It is a colourless liquid.
- (ii) It is flammable.
- (iii) Miscible with water, alcohol and ether.
- (iv) It has low boiling point of 56°C.
- (v) Has a characteristic sweet odour.

### Preparation of alkanones

Alkanones can be prepared by oxidation of alkanols.

## Activity 6.14

**Aim:** To prepare propanone by oxidation of propan-2-ol

### Requirements

- Potassium dichromate (VI)
- Propan -2-ol
- Concentrated sulphuric acid
- Anti-bumping granules
- Distilled water
- Dropping funnel
- Round bottom flask
- Conical flask.

### Procedure

1. Place 25% sulphuric acid in a round bottomed flask.
2. Add some anti-bumping granules to the flasks and set the apparatus as shown below

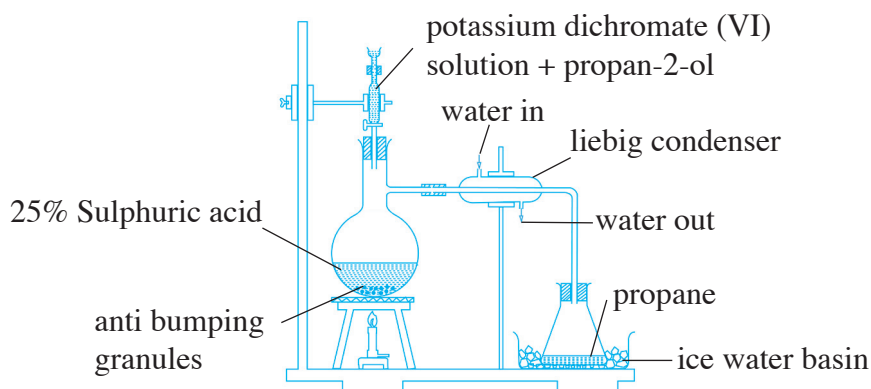
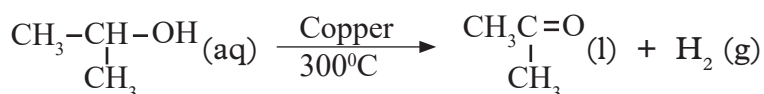

**Fig 6.12: Set-up for propanone preparation**

3. Heat the acid gently.
4. Drop a mixture of a propan-2-ol and aqueous potassium dichromate (VI) solution onto the hot acid.
5. Collect enough of the product.

### Other methods of preparing propanone

- (i) By dehydrogenation of propan-2-ol using heated copper.



(ii) By dry distillation of calcium ethanoate (calcium acetate).

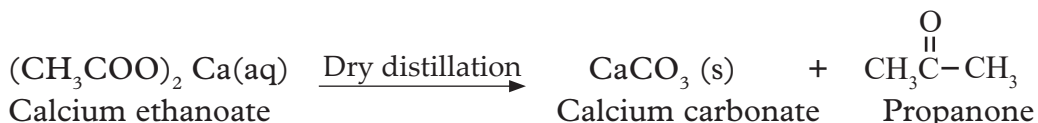

(iii) By Wacker process.

Propanone is prepared from propene by wacker process where propene and air mixture is passed through a solution of copper (II) chloride and palladium (II) chloride between 20°C and 60°C.

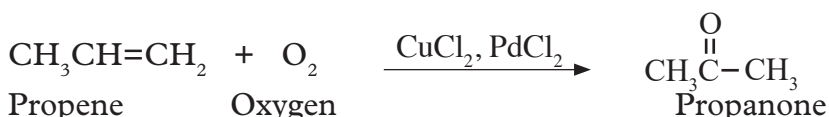

## Chemical properties of alkanones

Alkanones all show similar chemical properties. The following reactions of propanone discussed also apply to other alkanones.

### 1. Combustion of propanone

When propanone is ignited in plentiful supply of air or oxygen it burns with a blue flame to produce carbon dioxide and water.

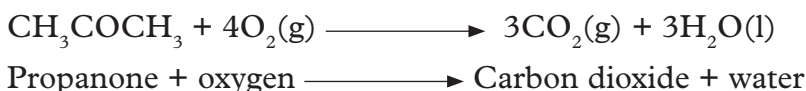

### 2. Effect on litmus

Propanone is a neutral substance. It has no effect on both red and blue litmus papers.

### 3. Oxidation of propanone

Alkanones are difficult to oxidize. They cannot be oxidised under conditions which alkanals get oxidized.

Any oxidation would break the carbon skeleton of alkanones. Strong oxidizing agent like hot concentrated nitric acid will oxidize alkanones with the effect of breaking the molecule to at least two molecules of alkanonic acid. Potassium manganate (VII) solution which is also a strong oxidizing agent will oxidise alkanones in a destructive way, breaking carbon-carbon bonds.

Hot copper metal catalyses oxidation of propanone to ethanal, carbon dioxide and water

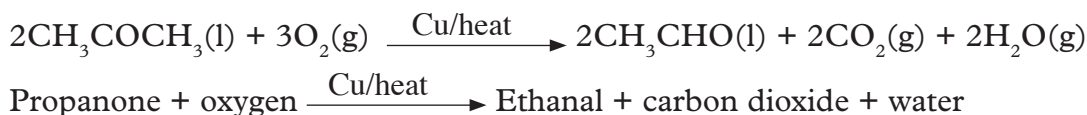

#### 4. Addition reaction

- a) Propanone will undergo addition reaction with hydrogen cyanide, HCN, to give 2-hydroxy-2-methylpropanonitrile.

Propanone + Hydrogen cyanide  $\longrightarrow$  2-hydroxy-2-methylpropanonitrile



- b) Propanone will also undergo addition reaction when shaken with saturated aqueous sodium hydrogen sulphite ( $\text{NaHSO}_3$ ). The reaction is not as fast as that of ethanal.

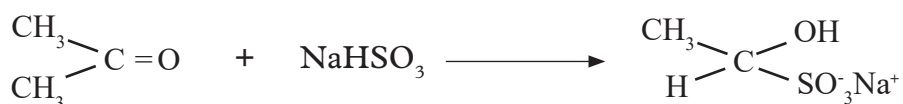

Propanone                      Sodium hydrogen sulphite                      Propanone sodium bisulphite

#### 5. Reduction reaction

Alkanones are reduced by hydrogen in the presence of a platinum or nickel metal catalyst to form secondary alcohols.

Propanone + Hydrogen  $\xrightarrow{\text{Ni}}$  Propan-2-ol

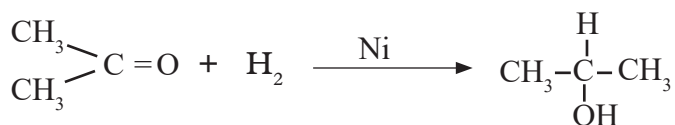

#### 6. Polymerization

Alkanones are not reactive enough to polymerize easily.

#### Test for alkanones

##### (a) Brady's test

##### *Procedure*

Place 2 cm<sup>3</sup> of propanone in a test tube, add 2 cm<sup>3</sup> of 2,4-DNPH reagent.

##### *Observation*

A yellow or orange precipitate is formed which gives a positive test for an alkanone (ketone). Both alkanals and alkanones give positive test with Brady's test.

2,4-dinitrophenyl hydrazine + propanone  $\longrightarrow$  2,4-dinitrophenyl hydrazone + water  
Yellow – orange

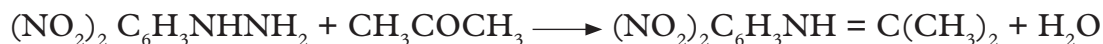

## b) Tollen's test

### *Procedure*

Add 2-3 cm<sup>3</sup> of propanone to 3 cm<sup>3</sup> of Tollen's reagent. If no reaction occurs, warm the test tube in water bath for few minutes.

It is advisable not to use excessive heating because it will give a false appearance of positive test ( a silver mirror) because of decomposition of the reagent.

### *Observation*

A negative test result indicates the compound is alkanone i.e a silver mirror does not form.

## c) Fehling's test or Benedicts solution

### *Procedure*

Add 5 cm<sup>3</sup> of propanone to 1 cm<sup>3</sup> of Fehling's solution and then heat in water bath for 5 minutes.

### *Observation*

If the colour of the solution does not change alkanone is present. Alkanone will not change the colour of Fehling's solution. Fehling's solution and Benedict's solution are variants of the same thing. Both contain complexes copper (II) ions in an alkaline solution.

## Uses of propanone

1. Propanone is used as a solvent for plastics and synthetic fibres.
2. Propanone is used as nail varnish remover.
3. Propanone is capable of dissolving plastic, glasses, jewelry, rayon's garments, pens and pencils.
4. Propanone is used as a solvent for both polar and non-polar compound.

### Check your progress 6.8

1. Write the molecular formula of the following alkanals.
  - (i) Butan-1-al
  - (ii) Pentan – 1-al
  - (iii) Butanone
  - (iv) Propanone
2. State tests that can be used to identify presence of a carbonyl group.
3. Explain the trend of melting points of alkanones in relation to their R.M.M.

## 6.10 Organic compounds

### Group Task

- Using reference materials such as textbooks and the internet carry out a research on the following organic compounds.
  - Aromatic compounds
  - Amino acids
  - Amines
- Write a report of your findings.
- Choose one member of the group to do a class presentation.
- Compare your findings with the rest of the class.

### The Facts

#### a. Aromatic compounds

Historically, benzene-like substances were called aromatic hydrocarbons because they had distinctive aromas. Today, an aromatic compound is any compound that contains a benzene ring or has certain benzene-like properties (but not necessarily a strong aroma)

In (IUPAC) system, aromatic hydrocarbons are named as derivatives of benzene. Figure below shows four examples. In these structures, it is immaterial whether the single substituent is written at the top, side, or bottom of the ring: a hexagon is symmetrical, and therefore all positions are equivalent.

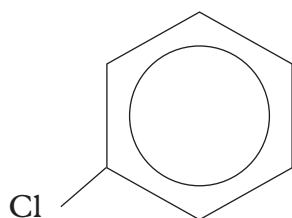

Chlorobenzene

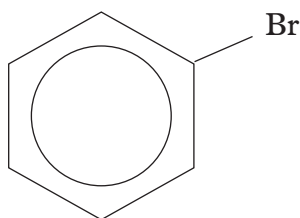

Bromobenzene

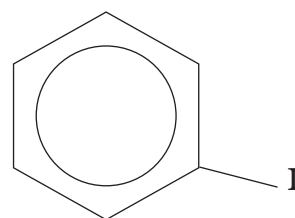

Iodobenzene

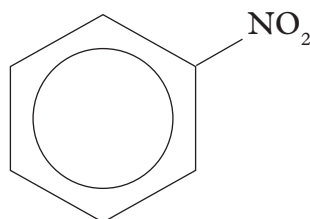

Nitrobenzene

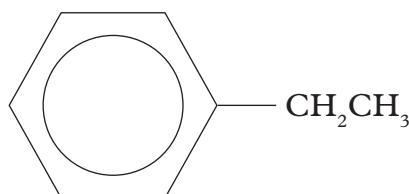

Ethylbenzene

Although some compounds are referred to exclusively by IUPAC names, some are more frequently denoted by common names, as is indicated below.

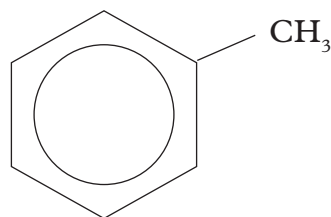

Toluene

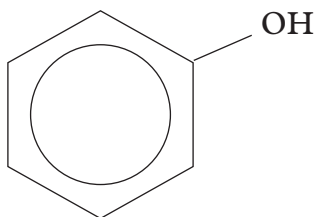

Phenol

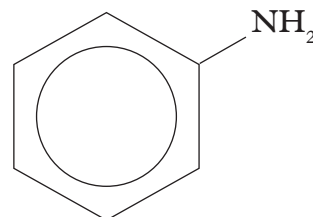

Aniline

## b) Amino acids

Amino acid, any of a group of organic molecules that consist of a basic amino group ( $-\text{NH}_2$ ), an acidic carboxyl group ( $-\text{COOH}$ ), and an organic  $R$  group (or side chain) that is unique to each amino acid. The term *amino acid* is short for  $\alpha$ -amino [*alpha-amino*] carboxylic acid. Each molecule contains a central carbon (C) atom, called the  $\alpha$ -carbon, to which both an amino and a carboxyl group are attached. The remaining two bonds of the  $\alpha$ -carbon atom are generally satisfied by a hydrogen (H) atom and the  $R$  group. The formula of a general amino acid is shown below.

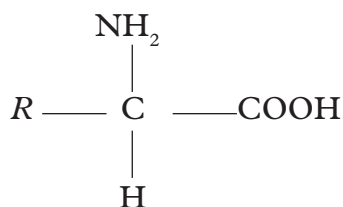

The amino acids differ from each other in the particular chemical structure of the  $R$  group.

## c) Amides

Amides are derived from carboxylic acids. A carboxylic acid contains the  $-\text{COOH}$  group, and in an amide the  $-\text{OH}$  part of that group is replaced by an  $-\text{NH}_2$  group. Amides contain the  $-\text{CONH}_2$  group.



The most commonly discussed amide is **ethanamide**,  $\text{CH}_3\text{CONH}_2$  (old name: acetamide)

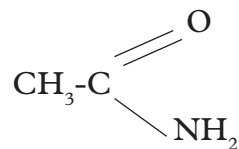

ethanamide

### Check your progress 6.14

1. Differentiate between:
  - a) Amino acids and amides
  - b) Carboxylic compounds and carbonyl compounds

### Learning outcomes

Knowledge and understanding	Skills	Attitudes
<ul style="list-style-type: none"> <li>Understand and explain nuclear reactions</li> </ul>	<ul style="list-style-type: none"> <li>Predict modes of nuclear decay reactions</li> <li>Calculate the rate of decay reactions and binding energy</li> </ul>	<ul style="list-style-type: none"> <li>Show concern for environmental safety</li> </ul>

### Introduction

Nuclear chemistry also known as radioactivity. Radioactivity is the spontaneous disintegration of an unstable nuclide leading to production of another nuclide and different composition with emission of particles and energy.

Substances which undergo radioactivity are said to be radioactive. Isotopes which are radioactive are said to be **radioisotopes**. A **nuclide** is an atom with defined mass number (number of protons and neutrons), atomic number and definite energy.

Radioactivity takes place in the nucleus of an atom unlike chemical reactions that take place in the energy levels involving electrons.

A nuclide is said to be stable if its neutron: proton ratio is equal to one ( $\frac{n}{p} = 1$ ). All nuclide therefore try to **attain**  $\frac{n}{p} = 1$  by undergoing radioactivity.

Examples

(i) Oxygen nuclide with  $^{16}_8\text{O}$  has 8 neutrons and 8 protons in the nucleus.

Therefore, the ratio  $\frac{n}{p} = 1$  thus it is stable and does not disintegrate.

(ii) Chlorine nuclide with  $^{35}_{17}\text{Cl}$  has 18 neutrons and 17 protons in the nucleus therefore, its  $\frac{n}{p} = 1.0588$  thus it is unstable and will try to disintegrate to attain  $\frac{n}{p} = 1$ .

(ii) Uranium nuclide with  $^{238}_{92}\text{U}$  has 146 neutrons and 92 protons in the nucleus therefore, with an  $\frac{n}{p} = 1.58696$  it is very unstable and more readily disintegrates to try to attain  $\frac{n}{p} = 1$ .

## 7.1 Types of radiations

There are three types of radiation:

- (i) Alpha ( $\alpha$ ) particles
- (ii) Beta ( $\beta$ ) particles
- (iii) Gamma ( $\gamma$ ) particles

### (i) Alpha( $\alpha$ ) particle decay

The alpha ( $\alpha$ ) particle has the following main characteristics:

- (i) positively charged (like protons)
- (ii) has mass number of **4** and atomic number of **2**. Therefore equal to a charged Helium atom  
 $({}^4_2\text{He}^{2+})$
- (iii) has very low penetrating power and thus can be stopped or blocked by a thin sheet of paper.
- (iv) has high ionizing power thus can cause a lot of damage to living cells.
- (v) a nuclide undergoing  $\alpha$ -decay has its mass number reduced by 4 and its atomic number reduced by 2.

### Examples of alpha decay

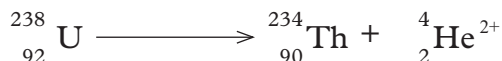
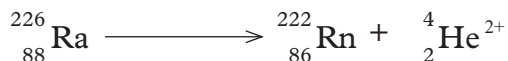
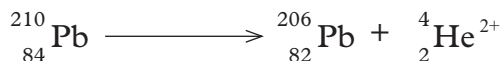

### Work To Do

Determine the values represented by letters in the following nuclear equations

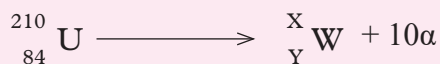
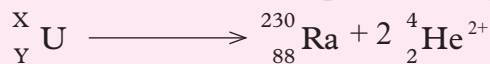

## (ii) Beta ( $\beta$ ) particle decay

Beta ( $\beta$ ) particle has the following characteristics:

- (i) negatively charged (like electrons).
- (ii) has no mass number but atomic number of negative one ( $-1$ ). It is therefore equal to a fast moving electron ( ${}^0_{-1}\text{e}$ ).
- (iii) medium penetrating power and thus can be stopped or blocked by a thin sheet of aluminium foil.
- (iv) medium ionizing power thus it causes less damage to living cells than the  $\alpha$  particle.
- (v) a nuclide undergoing  $\beta$ -decay has its mass number **remain** the same and its atomic number **increase** by 1.

### Examples of beta ( $\beta$ ) decay

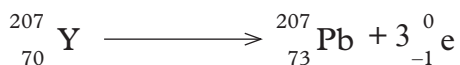
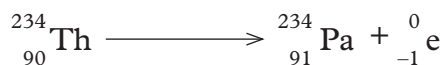
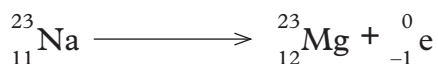

### Work To Do

With the help of a periodic table write nuclear equations for the following:

- (i)  ${}_{6}^{14}\text{C}$  undergoes one beta emission.
- (ii)  ${}_{0}^1\text{n}$  undergoes one beta emission.
- (iii)  ${}_{88}^{228}\text{Ra}$  undergoes four beta emissions.

## (iii) Gamma ( $\gamma$ ) particle decay

The gamma ( $\gamma$ ) particle has the following characteristics:

- (i) is neither negatively charged (like electrons/beta) nor positively charged (like protons/alpha), therefore it is neutral.
- (ii) has no mass number and atomic number therefore equal to electromagnetic waves.
- (iii) very high penetrating power and thus can be stopped or even by a thick block of lead.
- (iv) have very low ionizing power thus causes little damage to living cells unless on prolonged exposure.

(v) a nuclide undergoing  $\gamma$ -decay has its mass number and its atomic number remain the same.

## Penetrating power

The sketch diagram below shows the penetrating power of the radiations from a radioactive nuclide.

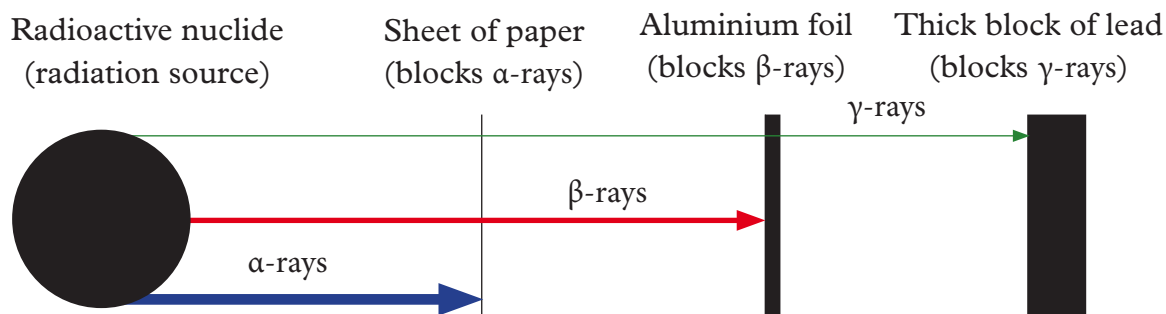

*Fig. 7.1: Penetrating power of radiations*

## Effect of electric or magnetic field on radiations

The sketch diagram below illustrates the effect of **electric** or **magnetic field** on the three radiations from a radioactive nuclide.

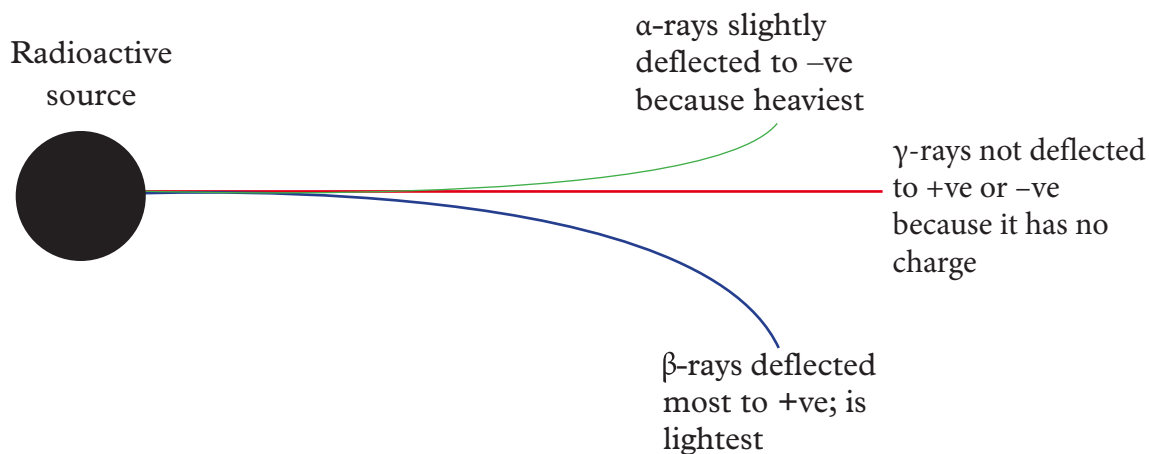

*Fig.7.2: Effect of electric or magnetic field on radiations*

## Decay series

Radioactive disintegration **naturally** produces the stable  $^{206}_{82}\text{Pb}$  nuclide /isotope of lead. Below is the  $^{238}_{92}\text{U}$  natural decay series. Identify the particle emitted in each case.

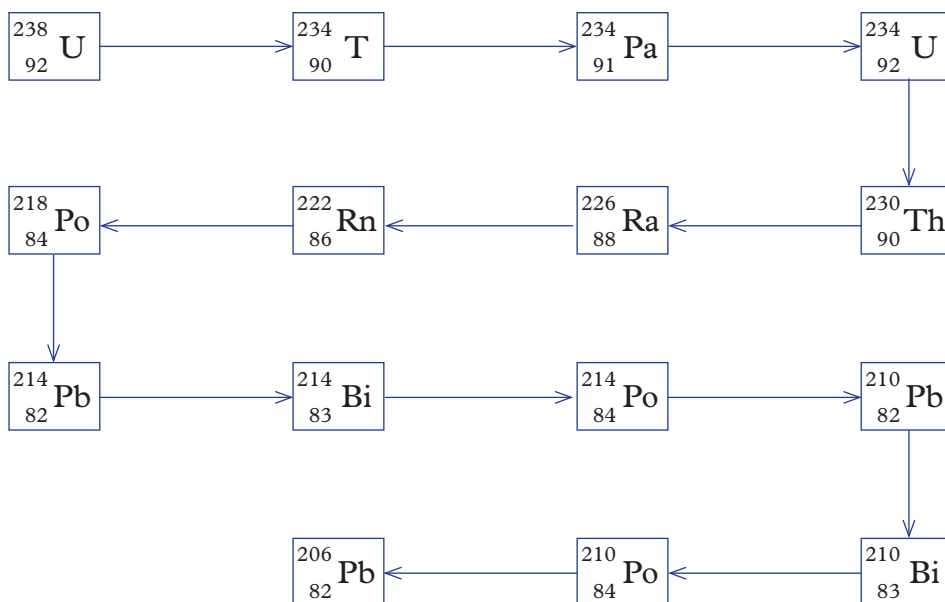

### Work To Do

- Write the nuclear equation for the disintegration from :
  - ${}_{92}^{238}\text{U}$  to  ${}_{90}^{234}\text{Th}$
  - ${}_{92}^{238}\text{U}$  to  ${}_{84}^{222}\text{Rn}$
- ${}_{90}^{230}\text{Th}$  undergoes alpha decay to  ${}_{86}^{226}\text{Ra}$ . Find the number of  $\alpha$  particles emitted. Write the nuclear equation for the disintegration.
- ${}_{82}^{214}\text{Pb}$  undergoes beta decay to  ${}_{83}^{214}\text{Bi}$ . Find the number of  $\beta$  particles emitted. Write the nuclear equation for the disintegration.
- ${}_{92}^{238}\text{U}$  undergoes beta and alpha decay to  ${}_{82}^{206}\text{Pb}$ . Find the number of  $\beta$  and  $\alpha$  particles emitted. Write the nuclear equation for the disintegration.

## 7.2 Nuclear fission and nuclear fusion

Radioactive disintegration/decay can be initiated in an industrial laboratory through two chemical methods:

- Nuclear fission
- Nuclear fusion.

### Nuclear fission

Nuclear fission is the process which a fast moving neutron hits a heavy unstable nuclide releasing lighter nuclide, daughter neutrons and a large quantity of energy.

Nuclear fission is the basic chemistry behind nuclear bombs made in the nuclear reactors.

The daughter neutron becomes again fast moving neutron hitting a heavy unstable nuclide releasing lighter nuclides, three more daughter neutrons each and a larger quantity of energy setting of a chain reaction.

*Example of nuclear equation showing nuclear fission*

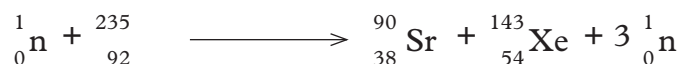

## Nuclear fusion

Nuclear fusion is the process which smaller nuclides join together to form heavier nuclides and releasing even a large-quantity of energy.

Very high temperatures and pressure is required to overcome the repulsion between the atoms.

Nuclear fusion is the basic chemistry behind sun radiation.

Two daughter nuclides of hydrogen fuse to form helium nuclide on the surface of the sun releasing large quantity of energy in form of heat and light.



## Nuclear binding energy

Nuclear binding energy is the energy that would be required to disassemble the nucleus of an atom into its component parts. These component parts are **neutrons** and **protons**, which are collectively called **nucleons**. The binding energy of nuclei is due to the attractive forces that hold these nucleons together, and it is always a positive number, since all nuclei would require the expenditure of energy to separate them into individual protons and neutrons.

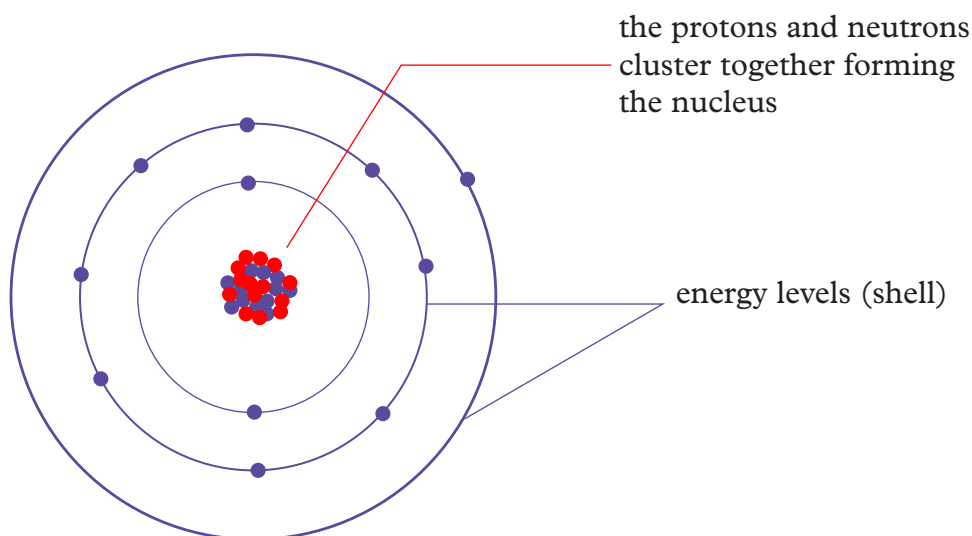

The mass of an atom is measured in atomic mass units.

There is a difference between the mass of an atom and the mass of its particles taken separately the difference is called **mass defect (delta m)**.

The mass defect is small compared to the total mass of the atom. The energy released when an atom is formed from its constituent particles is given by

Einstein's equation  $E = mc^2$

Where  $m$  = mass in kg

$C$  = speed of light ( $3.0 \times 10^8 \text{ m/s}$ )

$1 \text{ u} = 1.666065 \times 10^{-27} \text{ kg}$

### Calculation of binding energy

#### Worked Example

Given  ${}_{20}^{40}\text{Ca}$  and mass of the particles as follows

$$p = 1.00728 \text{ u}$$

$$n = 1.00867 \text{ u}$$

$$e = 0.00055 \text{ u}$$

$${}_{20}^{40}\text{Ca} = 39.96259$$

Calculate energy released when  ${}_{20}^{40}\text{Ca}$  is formed from its constituent particles.

#### Solution

$$\begin{aligned} \text{Mass of particles} &= (20 \times 1.00728) + (20 \times 1.008674) + (20 \times 0.00055) \\ &= 40.173948 \text{ u} \end{aligned}$$

$$\begin{aligned} \Delta m &= 40.173948 - 39.96259 \\ &= 0.211358 \end{aligned}$$

$$\text{In kg} = 0.211358 \times 1.66056 \times 10^{-27}$$

$$\text{But } E = mc^2$$

$$= 0.211358 \times 1.66056 \times 10^{-27} \times (3.0 \times 10^8)^2$$

$$= 3.1588 \times 10^{-11} \text{ Joules}$$

#### Work To Do

1. What change in mass defect takes place if a single atom of  ${}_{92}^{238}\text{U}$  breaks up into two  ${}_{46}^{110}\text{Pa}$  atoms and several neutrons. What energy is released?
2. What is the change in mass defect if  ${}^2_1\text{H}$  atom joins with a smaller atom to make a single atom of the nuclide  ${}^4_2\text{He}$ . What energy is released?



## 7.3 Rate of decay

During decay the radioactive elements reduce in mass. The decay occurs at different rates. Some will take microseconds while others will take thousands of years. The rate of disintegration is directly proportional to the number of atoms. The rate of decay of radioactive element is measured by its half life.

$$d\frac{N}{dt} \propto N$$

Where  $N$  = Number of atoms

$$d\frac{N}{dt} = \lambda N$$

Where  $\lambda$  = decay constant

$$\frac{1}{2}N = N_0 e^{-\lambda t}$$

Where;

$N$  = Number of radioactive atoms at time  $t$

$N_0$  = Number of atoms at the start i.e  $t = 0$

$t$  = time of decay at half life when  $t = \tau$  where  $\tau$  is the half life  $N = \frac{1}{2} N_0$

$$\frac{1}{2} N_0 = N_0 e^{-\lambda \tau}$$

now

$$\frac{1}{2} = e^{-\lambda \tau}$$

$$\ln 0.5 = \lambda \tau$$

$$0.6931 = \lambda \tau$$

$$\tau = \frac{0.6931}{\lambda}$$

A half-life is the time required for one of the initial number of atoms of a radioisotope to decay. After one half-life, half of the original radioactive atoms would have decayed.

### **Worked Example**

Calculate the half-life of a radioactive element X that has a decay constant of 0.25/s.

$$\tau = \frac{0.6931}{\lambda}$$

$$= \frac{0.6931}{0.25}$$

$$= 2.7724 \text{ seconds}$$

## Comparison between chemical reactions and nuclear reactions

Nuclear and chemical reaction have the following similarities:

- (i) Both involve the **subatomic** particles; electrons, protons and neutrons in an atom.
- (ii) Both involve the subatomic particles trying to make the atom more **stable**.
- (iii) Some form of **energy** transfer from or to the environment takes place.

**Table 7.1: Differences between nuclear and chemical reactions**

Nuclear reaction	Chemical reaction
1. Nuclear reactions mainly involve <b>protons</b> and <b>neutrons</b> in the nucleus of an atom.	1. Chemical reactions mainly involve outer <b>electrons</b> in the energy levels an atom.
2. Nuclear reactions form a new element.	2. Chemical reactions do not form new elements.
3. Nuclear reactions mainly involve evolution of large quantity of heat (energy).	3. Chemical reactions produce or absorb small quantity of heat/energy.
4. Nuclear reactions are accompanied by a loss in mass or mass defect. Do not obey the law of conservation of matter.	4. Chemical reactions are not accompanied by a loss in mass or mass defect hence obey the law of conservation of matter.
5. The rate of decay of the nuclide is independent of physical conditions (temperature/pressure /purity/particle size)	5. The rate of a chemical reaction is dependent on physical conditions such as, temperature/ pressure/ purity/ particle size/ surface area).

## 7.4 Applications of radioactivity in medicine

1. Radioactivity is used in medical imaging. Nuclear magnetic imaging uses small amounts of radioactive materials called **radiotracers** that are injected into the bloodstream, inhaled or swallowed. The radiotracer travels through the area being examined and gives off energy in the form of gamma rays which are detected by a special camera and a computer to create images of the inside of your body.
2. Gamma rays are used to sterilize surgical equipment.
3. Cancer treatment. Gamma rays are used in treatment of cancer in their very weak form since they are equally very dangerous. Cobalt-60 is the normally the source of this radiation for cancer treatment.

## Dangers of radiations

The radiations we have above have real serious dangers despite their usefulness learnt. For example, just small doses can lead to leukemia and other cancers. Very high doses will burn the skin and cause instant death, a concept used in the manufacture of atomic bombs.

Therefore, do not handle any radioactive materials unnecessarily. If one must work with radioactive substances use protective wears, take the shortest time possible and use correct handling equipment.

The world taking cognisance of great danger posed by radioactive materials have set up treaty for non use of chemical weapons and nuclear bombs in any war. Let us stop wars and promote peace for the development of our country and the rest of the world.

### Check your progress 7.1

1. How is radioactivity used in carbon dating.
2. What is background radiation and how is radiation detected?
3. Which isotope of carbon do you think would be radioactive. Explain why.

## GLOSSARY

**Activated complex:** An unstable arrangement of atoms that exists momentarily at the peak of the activation energy barrier. It represents an intermediate or transitional structure formed during the course of a reaction.

**Activation energy:** The minimum energy colliding particles must have in order to react.

**Addition polymerization:** The process that occurs when unsaturated monomers add to each other forming a polymer.

**Alkanols:** Organic compounds made of a hydrocarbon group and one or more hydroxyl group (OH) e.g. ethanol (C<sub>2</sub>H<sub>5</sub>OH).

**Alloy:** A material composed of two or more metals physically combined e.g. bronze or brass.

**Alpha particle ( $\alpha$ ):** A positively charged particle emitted from certain radioactive nuclei. It consists of two protons and two neutrons and is identical to the nucleus of a helium atom,

**Alpha radiation:** A stream of alpha particles emitted from a radioactive isotope.

**Amphoteric:** Capable of acting either as an acid or as a base, e.g. Zinc oxide is an amphoteric oxide.

**Amphoteric hydroxide:** A metal hydroxide which reacts with an acid or base producing salts in both cases, Al(OH)<sub>3</sub>, Zn(OH)<sub>2</sub>, Pb(OH)<sub>2</sub> are amphoteric hydroxides.

**Amphoteric oxide:** A metal oxide which reacts with an acid or a base producing salts in both cases PbO, ZnO, Al<sub>2</sub>O<sub>3</sub> are amphoteric oxides.

**Aqua regia:** A mixture of concentrated nitric acid and concentrated hydrochloric acid (it is capable of reacting with gold).

**Atomic bomb:** An explosive device whose vast source of energy is a nuclear fission reaction, e.g. uranium atomic bomb that was dropped in Japan during the 2<sup>nd</sup> world war.

**Basic solution:** Any solution in which the hydroxide ion (OH<sup>-</sup>) concentration is greater than the hydrogen ion (H<sup>+</sup>) concentration.

**Beta particle ( $\beta$ ):** A fast-moving electron emitted from certain radioactive nucleus; it is formed when a neutron changes into a proton.

**Beta radiation:** A stream fast-moving electrons (beta particles) emitted from a radioactive isotope.

**Blast furnace:** A tall cylindrical chamber in which iron(III) oxide is reduced to iron using coke (carbon), limestone and a blast of hot air.

**Bond dissociation energy:** The amount of energy required to break a bond between atoms. It is usually expressed in kJ per mol of substance.

**Bronze:** An alloy composed of copper and tin. Small amounts of zinc, lead and other metals may be added to give it special properties.

**Brass:** An alloy of copper and zinc.

**Cathode:** The negatively charged electrode at which reduction (gain of electrons) takes place during electrolysis. In primary or secondary cells, it is the electrode from which electrons emerge.

**Chain reaction:** A reaction which is self-sustaining because the products of one step of the reaction assists in starting further reaction, e.g. uranium nuclear fission is started by a neutron. The fission causes the production of more neutrons.

**Chemical equilibrium:** It is a state of “balance” in which forward and reverse reactions are taking place at the same rate; no net change in the amounts of reactants and products occurs in the chemical system.

**Condensation polymer:** A polymer formed by condensation reaction; for example, nylon which is produced by a condensation reaction between 1,6-diaminohexane and hexanedioic acid.

**Condensation reaction:** A reaction in which a simple molecule (for example, water or ammonia) is produced when reactant molecules join together to form a polymer.

**Contact process:** A process for making sulphuric acid in which the sulphur(IV) oxide and oxygen come into contact in the presence of a catalyst.

**Cross-linking:** The formation of side covalent bonds linking different polymer chains and therefore increasing the rigidity of the plastics. Thermosetting plastics usually contain many cross-links. See vulcanization of rubber also.

**Detergent:** Any substance in liquid or solid form which removes dirt physically from clothes, hands, utensils, e.g. Omo a cleansing agent.

**Dissociation:** The separation of the ions of an ionic substance when it dissolves in water.

**Denatured alcohol:** Ethanol to which a poisonous substance has been added to make it unfit for human consumption.

**Electrochemical cell:** A device that converts chemical energy into electrical energy.

**Electrochemical process:** The conversion of chemical energy into electrical energy or electrical energy into chemical energy. In an electrochemical cell, chemical energy is converted into electrical energy.

**Electrochemical series:** A table of metals or non-metals arranged in order of descending ease of losing electrons for metals or gaining electrons for non-metals.

**Electroplating:** The process of coating the surface of a metallic surface with a metal using electrolysis process, e.g. electroplating iron with zinc.

**Endothermic reaction:** A chemical change in which energy is absorbed, the energy content of the products is higher than the energy content of the reactants  $\Delta H$  has a positive value.

**Enthalpy:** The amount of heat that a substance has at a given temperature and pressure.

**Equilibrium position:** The relative concentrations of reactants and products of a reaction that has reached equilibrium; it indicates whether the reactants or products are favoured in the reversible reaction.

**Esters:** A family of organic compounds formed by esterification i.e. the reaction of an alkanol with alkanolic acid. They are characterised by strong and pleasant tastes and smells.

**Esterification:** The process of producing an ester by the reaction of an alkanolic acid and an alkanol.

**Excess reagent:** A reagent in a quantity that is more than sufficient to react with another or any reactant that remains after a reaction stops.

**Exothermic reaction:** A chemical change in which energy is released in form of heat; the energy content of the products is less than the energy content of the reactants i.e.  $\Delta H$  as a negative value.

**Faraday's constant:** The quantity of electricity transferred by one mole of electrons ( $6.0 \times 10^{23}$  electrons). It has a value of 96500 C/mol.

**Fermentation:** The production of ethanol from sugars by the action of yeast or bacteria. It is usually accompanied by evolution of heat and carbon(IV) oxide gas.

**Fission:** The break-up of a nucleus into medium-mass nucleus accompanied by the release of neutrons and a large amount of energy.

**Froth floatation:** A method commonly used to enrich sulphide ores of copper and lead by separating ore from gangue. Crushed ore is mixed with water and oil is blown through the mixture. The more pure ore is obtained as a froth which floats.

**Functional group:** The atom or group of atoms responsible for the characteristic chemical reactions of an organic compound. The chemistry of an organic compound is determined by its functional group.

**Fusion:** A reaction in which two light nuclei combine to produce a heavier and more stable nucleus accompanied by the release of a large amount of energy.

**Gamma-ray or radiation( $\gamma$ ):** High energy electromagnetic radiation, like X-ray, emitted by certain radioactive nuclei. They have no mass or electrical charge.

**Gangue:** The worthless sand and rock contained in freshly mined ore.

**Geiger counter:** A gas-filled metal tube used to detect the presence of radioactive radiations.

**Half-cell:** The part of a voltaic cell in which either oxidation or reduction occurs. It consists of a single electrode immersed in a solution of its ions.

**Heat of combustion:** The heat released during a chemical reaction in which one mole of a substance is completely burned in oxygen.

**Heat of neutralisation:** The heat change which takes place when one mole of hydrogen ions in solution is completely neutralised by one mole of hydroxyl ions in a solution of alkali.

**Heat of solution:** The heat absorbed or evolved when one mole of a substance is dissolved in a stated number of moles of water.

**Ionizing radiation:** Radiation which has enough energy to produce ions by knocking off electrons from the atoms it strikes.

**Ion exchange resin:** A resin which can exchange ions for positive ions, or one which exchange hydroxide ions for negative ions.

**IUPAC system:** An internationally accepted system of naming compounds proposed by the International Union of Pure and Applied Chemistry (IUPAC).

**Le Chatelier's principle:** When stress is applied to a system at equilibrium, the system changes to reduce the stress.

**Limiting reagent:** Any reactant that is used up first in a chemical reaction; it determines the amount of product that can be formed in the reaction.

**Nuclear equation:** An equation representing changes in the nuclei of atoms.

**Nuclear fission:** The splitting of an atomic nucleus of an element to form two or more atomic nuclei of different elements or another element and particle(s) like  $\beta$ -particles, neutrons, protons, etc. Energy is released in this type of reaction (nuclear energy).

**Nuclear fusion:** The process of combining two or more atomic nuclei of the same element or different elements to form an atomic nucleus of same or different element. Nuclear energy is released in this type of reaction.

**Nuclear reactor:** A set-up in which the controlled fission of radioactive material produces new substances for economic use, e.g. Chernobyl nuclear reactor.

**Ore:** A mineral used for commercial production of a metal.

**Oxidation:** There are three definitions of oxidation:

- A reaction in which oxygen is added to an element or compound or hydrogen is removed from an element or compound.
- A reaction involving the loss of electrons from an atom, molecule or ion.
- A reaction in which oxidation number of an element is increased.

[It is brought about by an oxidising agent].

**Oxidation number or state:** It is the apparent charge that an atom of an element has when in a molecule or ion.

**Oxidation-reduction reaction:** A reaction that involves the loss or gain of hydrogen or oxygen or transfer of electrons between reactants during a chemical change.

**Oxidising agent:** The atom, radical or ion which gives out oxygen or takes up hydrogen or takes up electron(s) during a chemical reaction. In the reaction the oxidising agent is reduced.

**Permanent hardness:** Hardness caused by the sulphates or chlorides of calcium and magnesium and can only be removed by addition of chemical softeners like  $\text{Na}_2\text{CO}_3$  but not by boiling.

**pH scale:** A scale with a range from 1 to 14, used for expressing the acidity or alkalinity of a solution. A neutral solution has a pH of 7

**Pig iron:** The form of iron obtained from the blast furnace. It contains high carbon content and other impurities making it brittle.

**Plastic:** Synthetic material which can be shaped while soft into required form and then hardened to produce a durable finished article, e.g. polyethene.

**Radioactive fall-out:** Radioactive fission products which have escaped into the atmosphere.

**Radioactive decay:** The process in which unstable nucleus emits radiations.

**Radioactivity:** The spontaneous uncontrollable decay (disintegration) of unstable nucleus of an atom with the emission of beta or alpha particles and gamma-rays producing a nucleus of different atomic number. This process is accompanied by release of energy.

**Radioisotopes:** Isotopes that have unstable nuclei and undergo radioactive decay.

**Reaction rate:** A measure of how fast a reaction takes place. [Particular reactions may be affected by the following factors the surface area of the solid reactants, the concentration of aqueous reactants or pressure of gaseous reactants, the temperature of the reactants, light and the use of a catalyst].

**Redox reaction:** Short form for Reduction–oxidation reaction.



**Reduction:** There are three definitions of reduction

- A reaction in which oxygen is removed from an element or compound or hydrogen is added to an element or compound
- A reaction involving gain of electrons by an atom, molecule or ion.
- A reaction in which oxidation number of an element is decreased. [It is brought about by a reducing agent].

**Reducing agent:** The atom, radical or ion which takes up oxygen or gives out hydrogen or gives out electrons during a chemical reaction. In the reaction, the reducing agent is oxidised.

**Reversible reaction:** A reaction in which the conversion of reactants into products (forward reaction) and the conversion of products into reactants (backward reaction) are possible depending on the physical conditions in which it is carried out.

**Roasting:** A process used to purify sulphide ores by heating the ore with air.

**Salt bridge:** A tube or porous material containing a conducting solution used to connect the half-cells in a voltaic cell; it allows the passage of ions from one half-cell to the other but prevents the solutions from mixing completely.

**Saponification:** The process of making soap by hydrolysis of an ester with a hot aqueous alkali.

**Slag:** The fused waste material from a smelting process; it is usually composed of silicates.

**Smelting:** A process in which impurities are removed from an ore by melting.

**Soapless detergents:** Cleansing agent which do not contain a carboxylate ion as its polar end, but have  $-\text{OSO}_3^-\text{Na}^+$ .

**Soaps:** Cleansing agent which contain a carboxylate ion as its polar end. [They are formed by a process called saponification].

**Solubility:** The mass in grams of a substance that will saturate 100 g of a solvent at a particular temperature.

**Solubility curve:** A graph showing how the solubility of a substance in a solvent changes with temperature.

**Specific heat capacity:** The quantity of heat required to raise the temperature of 1 g of a substance by  $1^\circ\text{C}$ .

**Spontaneous reaction:** A reaction that takes place without application of external energy (heat or light), e.g. nuclear reactions, neutralization of a strong acid/strong base.

**Standard electrode potential:** Electrode potential of the metal when it is in contact with 1 molar solution of its metallic ions at  $25^\circ\text{C}$  when measured using a standard hydrogen electrode as the reference.

**Standard hydrogen electrode potential:** This is the electrode potential when one atmosphere of hydrogen gas is in contact with 1 mole of hydrogen ions. It is arbitrarily taken as zero.

**Strong acid:** An acid that is completely (or almost completely) dissociated to form ions in aqueous solution e.g. sulphuric acid.

**Strong base:** A base that completely dissociates into metal ions and hydroxide ions in aqueous solution e.g. sodium hydroxide solution.

**Strong electrolyte:** A solution in which a large portion of the solute exists as ions.

**Temporary hardness:** Hardness of water caused by the hydrogencarbonate of calcium and magnesium, which can be removed by boiling the water.

**Thermochemical equation:** A chemical equation that includes the amount of heat produced or absorbed during the reaction.  $\Delta H$  is -ve for exothermic reaction and +ve for endothermic reaction.

**Thermoplastics:** Plastics which soften when heated. They can be re-moulded e.g. polyethene, PVC and nylon.

**Thermosetting plastics:** Plastics which do not soften on heating but only harden and decompose. They cannot be re-moulded, e.g. Bakelite.

**Water softener:** A chemical substance which is added to hard water to remove hardness, e.g. sodium carbonate

**Water softening:** The Process by which hardness is removed from water.

**Weak acid:** An acid that partially dissociates into ions in aqueous solution e.g. ethanoic acid.

**Weak base:** A base that partially dissociates in aqueous solution e.g. ammonium hydroxide.

**Weak electrolyte:** A solution in which only a fraction of the solute exists as ions.

**Zincate:** A salt of zinc hydroxide when it acts as a feeble acid.

## Appendix I

Atomic numbers and relative atomic masses of some elements

Element	Symbol	Atomic number	Relative atomic mass
Aluminium	Al	13	27
Argon	Ar	18	40
Barium	Ba	56	127
Beryllium	Be	4	9
Boron	B	5	11
Bromine	Br	35	80
Calcium	Ca	20	40
Carbon	C	6	12
Chlorine	Cl	17	35.5
Chromium	Cr	24	52
Copper	Cu	29	63.5
Fluorine	F	9	19
Gold	Au	79	197
Helium	He	2	4
Hydrogen	H	1	1
Iodine	I	53	127
Iron	Fe	26	56
Krypton	Kr	36	84
Lead	Pb	82	207
Lithium	Li	3	7
Magnesium	Mg	12	24
Manganese	Mn	25	55
Mercury	Hg	80	207
Neon	Ne	10	20
Nickel	Ni	28	59
Nitrogen	N	7	14
Oxygen	O	8	16
Phosphorus	P	15	31
Potassium	K	19	39
Silicon	Si	14	28
Silver	Ag	47	108
Sodium	Na	11	23
Sulphur	S	16	32
Tin	Sn	50	119
Vanadium	V	23	51
Zinc	Zn	30	65

# APPENDIX II

## Periodic table

x is the Relative Atomic Mass (RAM)  
 Z is the symbol of the element  
 y is the Atomic Number of the element

$\overset{x}{Z}$	Name
------------------	------

Periods	I	II	III	IV	V	VI	VII	VIII	IX	X
1	1 H Hydrogen									2 He Helium
2	3 Li Lithium	4 Be Beryllium				8 O Oxygen	9 F Fluorine			10 Ne Neon
3	11 Na Sodium	12 Mg Magnesium				16 S Sulphur	17 Cl Chlorine			18 Ar Argon
4	19 K Potassium	20 Ca Calcium				32 Ge Germanium	33 As Arsenic			36 Kr Krypton
5	37 Rb Rubidium	38 Sr Strontium				50 Sn Tin	51 Sb Antimony			54 Xe Xenon
6	55 Cs Caesium	56 Ba Barium				82 Pb Lead	83 Bi Bismuth			86 Rn Radon
7	87 Fr Francium	88 Ra Radium				114 Po Polonium	115 Uup Ununpentium			118 Uuo Ununoctium

Transition metals

Periods	I	II	III	IV	V	VI	VII	VIII	IX	X
7	223 Fr Francium	226 Ra Radium	227 Ac Actinium							
6	133 Cs Caesium	137 Ba Barium	175 Lu Lutetium							
5	86 Rb Rubidium	88 Sr Strontium	89 Y Yttrium							
4	39 K Potassium	40 Ca Calcium	89 Y Yttrium							
3	11 Na Sodium	12 Mg Magnesium	24 Mg Magnesium							
2	3 Li Lithium	4 Be Beryllium	9 Be Beryllium							
1	1 H Hydrogen									2 He Helium

### Lanthanides

### Actinides



South Sudan

# Secondary Chemistry 4

Student's Book

Secondary Chemistry has been written and developed by Ministry of General Education and Instruction, Government of South Sudan in conjunction with Subjects experts. This course book provides a fun and practical approach to the subject of Chemistry, and at the same time imparting lifelong skills to the students.

The book comprehensively covers the Secondary 4 syllabus as developed by Ministry of General Education and Instruction.

**Each year comprises of a Student's Book and Teacher's Guide.**

**The Student's Books provide:**

- Full coverage of the national syllabus.
- A strong grounding in the basics of chemistry.
- Clear presentation and explanation of learning points.
- A wide variety of practice exercises, often showing how chemistry can be applied to real-life situations.
- It provides opportunities for collaboration through group work activities.
- Stimulating illustrations.



All the courses in this secondary series were developed by the Ministry of General Education and Instruction, Republic of South Sudan. The books have been designed to meet the primary school syllabus, and at the same time equipping the pupils with skills to fit in the modern day global society.

This Book is the Property of the Ministry of General Education and Instruction.

**This Book is not for sale.**

Any book found on sale, either in print or electronic form, will be confiscated and the seller prosecuted.

**Funded by:**



**Published by:**

