

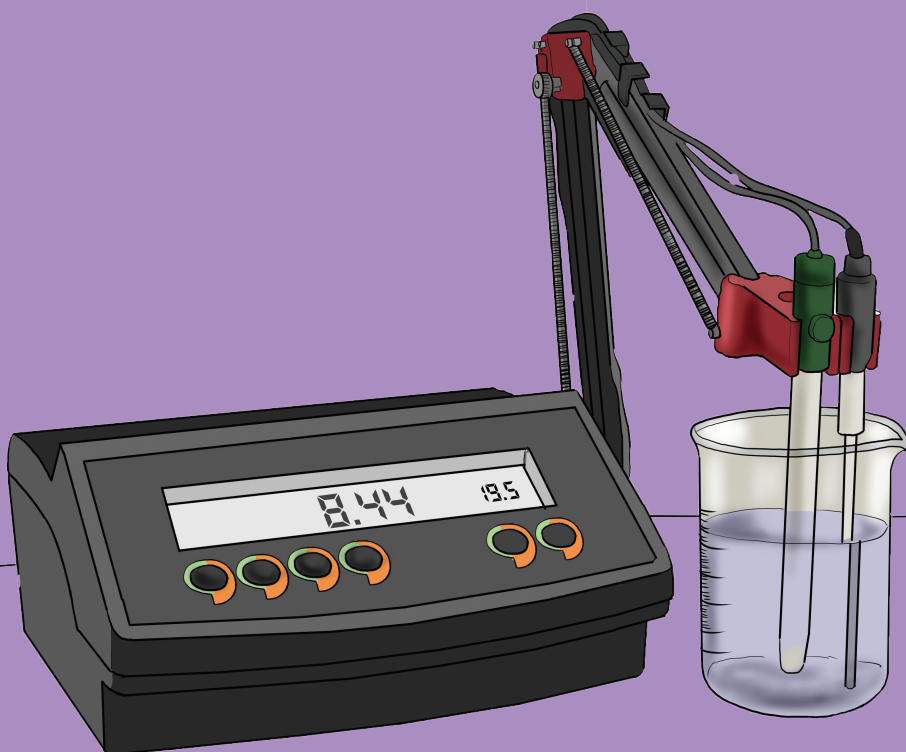


South Sudan



# Secondary Chemistry<sup>1</sup>

Student's Book



This Book is the Property of the  
Ministry of General Education  
and Instruction.

**This Book is not for sale.**

Funded by:



## **How to take care of your books.**

### Do's

1. Please cover with plastic or paper. (old newspaper or magazines) Please make sure you have clean hands before you use your book. Always use a book 2. marker do not fold the pages.
3. If the book is damaged please repair it as quickly as possible. Be careful who you lend your schoolbook to.
4. Please keep the book in a dry place.
5. When you lose your book please report it immediately to your teacher.

### Don'ts

1. Do not write on the book cover or inside pages.
2. Do not cut pictures out of the book.
3. Do not tear pages out of the book.
4. Do not leave the book open and face down.
5. Do not use pens, pencils or something thick as a book mark.
6. Do not force your book into your schoolbag when it is full.
7. Do not use your book as an umbrella for the sun or rain.
8. Do not use your book as a seat.

South Sudan

SECONDARY

1

# Chemistry

## Student's Book 1



This book is the property of the Ministry of General Education and Instruction.

**THIS BOOK IS NOT FOR SALE**

Funded by:



GLOBAL  
PARTNERSHIP  
for EDUCATION

quality education for all children

Published in 2018 by:  
Longhorn Publishers (K) Ltd.,  
Funzi Road, Industrial Area,  
P.O. Box 18033 – 00500,  
Nairobi, Kenya.

©2018, THE REPUBLIC OF SOUTH SUDAN, MINISTRY OF GENERAL  
EDUCATION AND INSTRUCTION.

All rights reserved. No part of this book may be reproduced by any means  
graphic, electronic, mechanical, photocopying, taping, storage and retrieval  
system without prior written permission of the Copyright Holder.

Pictures, illustrations and links to third party websites are provided  
in good faith, for information and education purposes only.

# Table of contents

<b>Unit 1 Separating mixtures and compounds</b> . . . . .	<b>1</b>
1.1 Definition of chemistry . . . . .	1
1.2 Importance of chemistry . . . . .	2
1.3 The chemistry laboratory . . . . .	5
1.4 Separation of mixtures and compounds . . . . .	21
1.5 Application of separation of mixtures and compounds . . . . .	35
<b>Unit 2 Particulate nature of matter, formulae and chemical equations</b> . . . . .	<b>43</b>
2.1 The states of matter . . . . .	43
2.2 Changes of states of matter . . . . .	44
2.3 Physical and chemical properties of matter . . . . .	46
2.4 Kinetic theory of matter . . . . .	55
2.5 Change of state and kinetic theory . . . . .	56
2.6 Definition of element, atom, and molecule . . . . .	62
2.7 Symbols of chemical elements . . . . .	63
2.8 Main components of an atom . . . . .	65
2.9 Atomic characteristics . . . . .	65
2.10 Electronic configuration . . . . .	67
2.11 Elements and compounds . . . . .	71
2.12 Formation of ions . . . . .	71
2.13 Radicals . . . . .	73
2.14 Valence of elements and radicals . . . . .	74
2.15 Chemical formulae and nomenclature . . . . .	74
<b>Unit 3 Acids, Bases and salts</b> . . . . .	<b>82</b>
3.1 Definition of acid, base, indicator and salt . . . . .	83
3.2 Properties of acids and bases . . . . .	87
3.3 Strong and weak acids . . . . .	89
3.4 Simple acid –base indicator . . . . .	92
3.5 The pH scale . . . . .	96
3.6 Uses of acids and bases . . . . .	100
3.7 Types of salts . . . . .	104

<b>Unit 4 Redox reactions</b> .....	<b>107</b>
4.1 Oxidation and reduction .....	108
4.2 Oxidising and reducing agents .....	112
4.3 Oxidising numbers .....	115
4.4 The reactivity series .....	120
<b>Glossary</b> .....	<b>129</b>
<b>Appendix I</b> .....	<b>138</b>
<b>Appendix</b> .....	<b>139</b>

# UNIT 1

## Separating mixtures and compounds

Learning outcomes		
Knowledge and understanding	Skills	Attitudes
<ul style="list-style-type: none"><li>Name common laboratory apparatus and understand safety rules.</li><li>Explain the techniques of separating mixtures and compounds and link the concepts to industry, especially crude oil.</li></ul>	<ul style="list-style-type: none"><li>Separate a range of mixtures and compounds.</li><li>Investigate the parts of non-luminous flame.</li><li>Present reasoned explanations for phenomena, patterns and relationships.</li><li>Make predictions and propose hypotheses.</li><li>Record observations, measurements and estimates.</li><li>Interpret and evaluate observations and experimental results.</li><li>Plan investigations, select techniques, apparatus and materials.</li><li>Evaluate methods of investigations.</li></ul>	<ul style="list-style-type: none"><li>Appreciate knowledge of chemistry in daily life.</li><li>Respect for safety rules in laboratory.</li><li>Develop precision and accuracy in taking measurements.</li><li>Appreciate the different techniques of separating mixtures in daily life.</li></ul>

### Introduction

#### Activity 1.1

In groups, study the photographs below.



*Fig. 1.1 Some products made using the knowledge of chemistry*

Discuss with your friend how the things in the photographs came about. Are they important in our lives? Describe how?

### 1.1 Definition of Chemistry

#### Activity 1.2

In groups, discuss the following:

1. Look around you. What artificial things can you see or smell?
2. What are those things made of?

3. Think about how the materials that make up the things you have observed are arranged.
4. Did you know that the things you have mentioned change when interfered with? Why would this be the case?
5. Try out these experiments:
  - Light a piece of candle. What happens?
  - Put some sugar or salt in a glass of water. Stir using a spoon or stick. What happens to the sugar or salt?

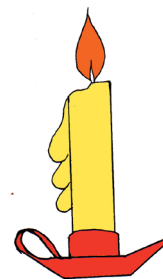


Fig. 1.2 A burning candle

### Work to do

1. Check the meaning of the word “Chemistry” in the dictionary or the Internet.
2. Discuss the meaning of the word Chemistry in your group.
3. Write the definition in your notebook.
4. Compare your definition with that of other group members. Are they the same?

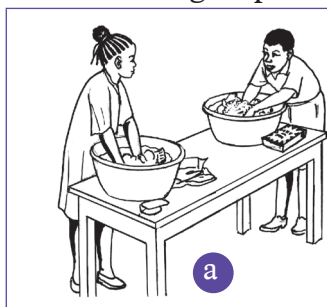
### The facts

The word **Chemistry** refers to the study of the composition, structure and properties of substances under different conditions. For example, you may be interested to know what happens when a piece of wood burns or during souring of milk. You may also want to know what happens when a nail undergoes rusting. All these are studied under Chemistry as a subject.

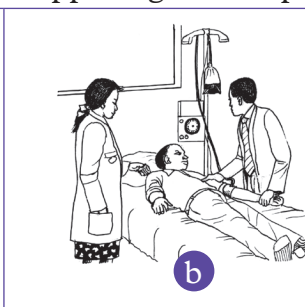
## 1.2 Importance of Chemistry

### Activity 1.3

1. Study the pictures below.
2. Discuss in groups what is happening in each picture.



a

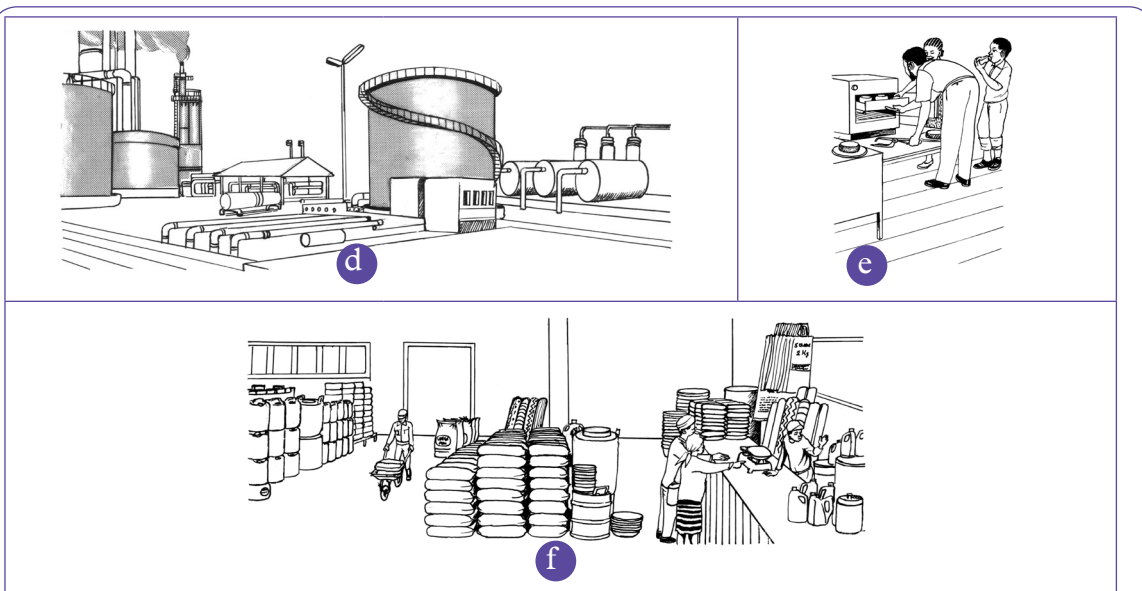


b



c





*Fig. 1.3*

3. How are the events in the pictures relevant in our lives?
4. What would happen if the events in the pictures did not occur?
5. Write short notes in your notebook on the importance of Chemistry in our lives.
6. Choose a secretary to do a presentation to the rest of the class on your findings.

### Activity 1.4

1. Look at the products given by your teacher. Have you ever come across them? What are they used for?
2. Now, think about the products that you use at home. List them down in your notebook. Compare the products given by your teacher with your list.
  - How important are these products to you?
  - Is there anything that will happen if you fail to use some of the products? Give a list of such products.
  - Where do you think these products come from?
  - How are the products manufactured?
  - What kind of knowledge do you think is required for these products to be made?
3. Your teacher will now take you for a trip in a manufacturing factory. Find out the answers to the questions above during the trip.
4. Write a report and present it to the rest of the class.

## The Facts

Chemistry plays a very important role in our lives. For example:

- The soaps and detergents that we use for cleaning are manufactured using the knowledge of chemistry.
- Medicines and pharmaceutical products are also manufactured using chemistry knowledge.
- In food industry, we use chemistry knowledge, for example, when baking and processing drinks.
- Chemistry knowledge is used when treating drinking water.
- We also use chemistry knowledge when processing crude oil and when manufacturing agricultural products like fertilisers and pesticides among others.



*Fig 1.4 An Oil Refinery*

- Other products such as clothes, paints, metal alloys and plastic products are done by applying the knowledge of Chemistry.

### ***My environment my life!***

*Re-use and recycle plastic products. They are not biodegradable. If thrown in the environment, they pollute soil i.e. they destroy the soil structure and suffocate useful microorganisms.*

Further, we can use chemistry to earn a living. Careers that you can pursue after studying Chemistry include:

- Chemical engineer
- Chemistry teacher
- Metallurgist
- Nutritionist
- Quality control officer
- Pharmacist
- Laboratory worker

### **Work to do:**

Think of other ways in which chemistry is beneficial to us. Come up with a list in your notebooks. Compare your work with that of other class members.

### *We are all equal!*

*It is possible for anybody irrespective of gender or physical state of the body to pursue a career in Chemistry. No career is a preserve of one gender or people without physical challenges!*

### Check your progress 1.1

1. What is chemistry?
2. How will the study of Chemistry help you in your future career?
3. How do you think that the study of chemistry is important in the environmental conservation of South Sudan?
4. How is the knowledge of Chemistry important in the following areas?
  - (a) Water treatment
  - (b) Agriculture
  - (c) Transport industry
  - (d) Pharmaceutical industry

### 1.3 The Chemistry laboratory

#### Work to do

1. Think of your school laboratory. Why do you think it has many sections e.g. fume chamber, cupboards, shelves, sinks e.t.c?
2. What is the purpose of each section?
3. What are the items found in each section?
4. Why do you think it is important to exercise care in the laboratory?

#### The Facts

Many houses are always built with a number of rooms. Every room is usually reserved for a particular purpose. Some items are kept in certain rooms due to certain reasons i.e. they could be delicate and expensive and can easily be damaged. Similarly, Chemistry is studied in a place known as a laboratory.

Chemistry as a subject is sometimes learnt through practical activities known as **experiments** done in the laboratory. A laboratory is therefore a room, building or institution equipped for scientific research or where experimentation are done. In the laboratory, you will find equipment, materials and chemicals which are used when performing these experiments. Students need to conduct themselves with care and in an orderly manner while in the laboratory so as to avoid injuries and accidents that could occur. Safety rules and regulations are put in place to guide students when using the laboratory.



Fig. 1.5 A laboratory

## Laboratory safety rules and regulations

### Work to do

#### *In groups*

1. Research and make a presentation on laboratory rules and regulations. Write them down in your notebook.
2. Go through the laboratory safety rules in the chart provided by your teacher. Compare it with your findings.

#### *The Facts*

Many laboratory chemicals are poisonous while some easily catch fire. Some of the chemicals are also corrosive when they come in contact with the skin. Also some laboratory apparatus are fragile, others are delicate while others are sharp or pointed hence can harm us. It is therefore necessary that rules and regulations are followed to ensure safety while in the laboratory.

**The following are some of the rules that need to be respected while in the laboratory:**

1. Do not enter the laboratory without the **teacher's permission**.

#### *Health check!*

*Always avoid situations that can put your health at risk such as eating or tasting food in the laboratory. Our health must always be given first priority.*

2. Always **consult your teacher** before trying out any experiment, handling apparatus or chemicals. Do not interfere with other students' experiments as well.
3. **Do not smell gases directly.** Hold the gas source 15-20 cm away from the nose and waft the gas towards the nose using your palm, then smell carefully.
4. **Label all reagents** you are using to avoid confusion. Always read the label on all reagents before you use them.

### *My environment my life!*

*Proper disposal of wastes ensures an effective working environment.*

5. **Report any accidents to the teacher** or the laboratory technician immediately they occur for necessary action to be taken.

#### Activity 1.5

1. What is not relevant in the event of an emergency?
  - (a) Completing the experiment
  - (b) Evacuation of the building
  - (c) Emergency procedure
  - (d) Where to assemble
2. Spilling of chemicals or accidents such as breaking glassware may occur while performing an experiment.  
Discuss what you would do in such a scenario.

#### Laboratory safety symbols and their meanings

#### Activity 1.6

*In groups,*








1. **Do research to find out the various safety symbols used in the laboratory.**
2. **Cut a manila paper into seven square pieces.**
3. Using a marker pen, draw the various safety symbols on the pieces of manila.
4. Write the meaning of each symbol below it in capital letters.
5. Pin the symbols on the noticeboard of your classroom to remind others of their safety while in the laboratory.
6. Role-play the meaning of each symbol. For example, make a loud noise resembling an explosion. Let your friends try to move away from the scene in an organised way. Also, scratch your skin on the hand as if in pain. Let your friend do first aid on you by pouring a lot of water on the affected part.

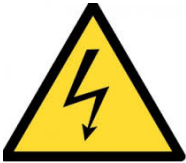

#### The Facts

In addition to safety rules and regulations there are also symbols and labels majorly used to warn the users of a laboratory. For example, many of the reagent containers have warning labels on them. Warning labels are small pieces of instructions that are aimed at helping users to avoid danger. It is therefore important to read and interpret the various warning labels and symbols. Some of the symbols are placed at strategic points in the laboratory. Example of such symbols are given in table 1.1

below.

*Table 1.1: Laboratory safety symbols and their meanings*

Symbol	Meaning
 Highly flammable	– Easily catches fire and burns.
 Toxic	– It can lead to death.
 Irritant	– It irritates the skin when in contact.
 Radioactive	– Dangerous to human health and can cause cancer.
 Corrosive	– Can easily burn you when in contact with your skin. It can also damage wood and metal.
 Explosive	– It can easily explode and release small particles which can injure you.
 Harmful	– Poisonous when inhaled or ingested and can lead to death.

 <p>Electric shock</p>	<p>– It can cause electric shock leading to death.</p>
 <p>Laser radiations</p>	<p>– It can cause cancer.</p>

## Laboratory apparatus

### Work to do

1. Study the instrument in Fig 1.6. Do you recognize it?
2. Suggest the use of the instrument.
3. How would you tell the volume of water in a container?
4. How can one measure the coldness or hotness of a substance?



*Fig 1.6*

We use laboratory apparatus for various functions. The word **apparatus** refers to the set of equipment used by chemists to perform experiments. They may be made of metal, wood, plastic or glass. It is important to use the right apparatus when performing a given experiment. One should also be aware of the accuracy of apparatus before using them.

### Work to do

1. In groups, discuss whether the clinical thermometers used today are filled with mercury. If so, do you think mercury is corrosive or poisonous.
2. What would you do incase the thermometer breaks and the mercury spills on your hand?

## Activity 1.7

*In pairs;*

1. Check the temperature reading of a thermometer. This is the room temperature.
2. Move out of the room with the thermometer and record the new temperature reading.
  - Why do you think the temperature reading changes when you get out of the room?
  - Compare your temperature reading with those of other groups. Is there any difference?
4. In pairs, discuss on the suitable apparatus to measure 17 g of sulphur, 20 g of sand, 2.5 g of common salt.

### The Facts

There are different apparatus for different functions in the laboratory. There are apparatus used for measurement of volume, temperature, mass and time. Others are used as a source of heat. Most of the apparatus and reaction vessels are made of **transparent glass or plastic material**. This allows us to observe reactions taking place inside and to also read accurate levels of liquids. Glass and plastics do not also react with most of the reagents used in the laboratory.

#### (a) Apparatus for measuring volume

### Work to do

*In pairs*

1. Use a burette to measure 20 cm<sup>3</sup>, 50 cm<sup>3</sup> and 75 cm<sup>3</sup> of water.
2. Propose other apparatus found in the laboratory that you can use to measure volume.
3. Share your answers with the rest of the class.

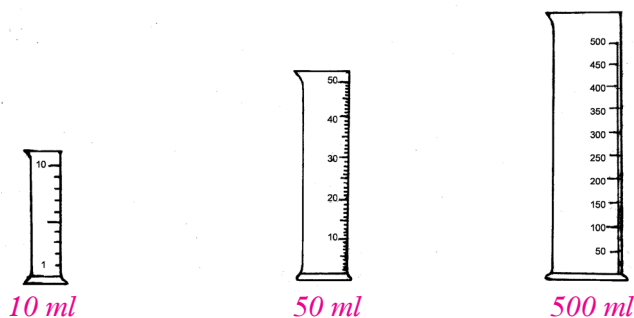
### The Facts

Apparatus used for measuring volume include measuring cylinder, burette, pipette and the volumetric flask.

#### (i) Measuring cylinders

Measuring cylinders are made of transparent glass or plastic. Measuring cylinders have different capacities. They are used for measuring **approximate** volumes of liquids or solutions.





*Fig 1.7 Measuring cylinders of different capacities*

### **(ii) Burette**

A burette is used for measuring **accurate** volumes of liquids or solutions during chemical analysis.

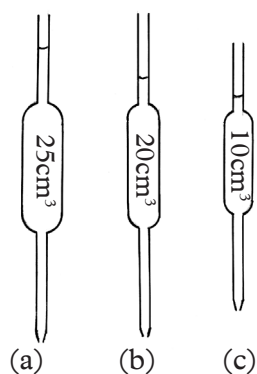


*Fig. 1.8 Burette*

A burette has a tap at one end. The tap enables the user to release liquids, drop by drop. It is also calibrated and the zero mark is at the top of the scale. This is because the burette measures how much liquid flows out.

### **(iii) Pipette**

Pipette is used for transferring **exact quantities** of liquids or solutions during chemical analysis. Different pipettes measure different volumes of liquid as shown in fig 1.9 a, b, c .



*Fig 1.9 Pipettes*

#### (iv) Syringes

Syringes are also used to measure accurate volumes of liquids and solutions. Syringes could be of various capacities.



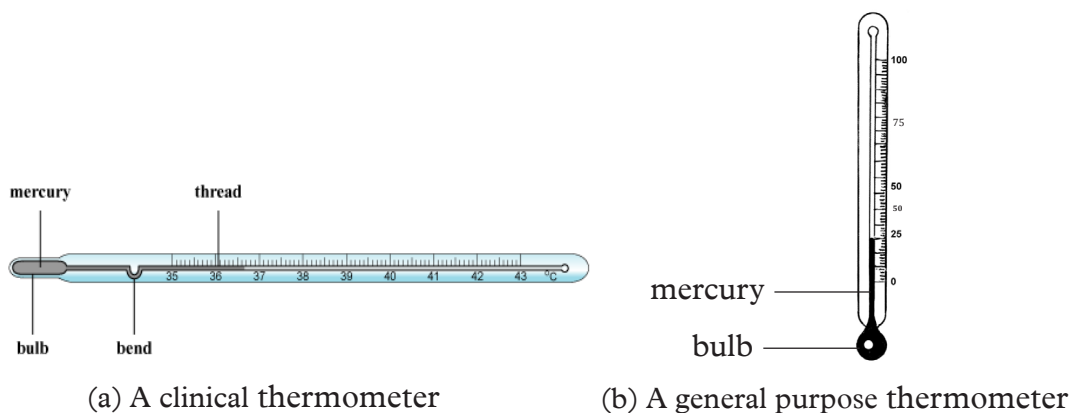
*Fig 1.10 A 30ml Syringe*

#### (b) Apparatus for measuring temperature

Temperature is measured using a **thermometer**. There are different types of thermometers.

- Clinical thermometer
- General-purpose thermometer

In Chemistry, we use general purpose thermometers. Clinical thermometers are used to measure body temperature in hospitals. They have a bend or a constriction to prevent backflow of mercury after use.



*Fig 1.11 Different types of thermometers*

**Note:** Thermometer readings are usually expressed in degrees Celcius ( $^{\circ}\text{C}$ ). However, Kelvin (K) is sometimes used.

### (c) Apparatus for measuring mass

#### Work to do

1. In pairs, weigh the items provided by your teacher.
2. Can you identify the weighing balances you just used?
3. What is the difference between them?

#### The Facts

Mass is measured using **weighing balances**. There are different types of weighing balances. Examples are **electronic** and **beam balances** shown below. An electronic balance is preferred in measuring more accurate masses of substances. Mass is measured in grams (g) or in kilograms (kg).

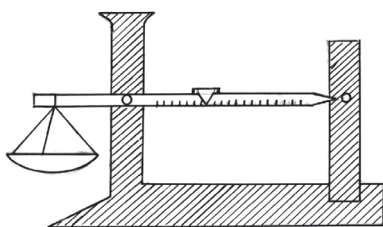


Fig 1.12 (a) Beam balance



Fig 1.12 (b) Electronic balance

### Sources of heat in the laboratory

#### Work to do

1. While in the laboratory, can you identify the apparatus used as sources of heat?
2. Have you ever come across any of them while at home?

#### The Facts

Heating substances in the laboratory is always an exciting experience. It is important to use the correct apparatus for heating.

Apparatus used as sources of heat in the laboratory include: Bunsen burner, spirit lamp and stove.

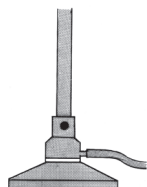


Fig 1.13 (a) Bunsen burner



Fig 1.13 (b) Stove



Fig 1.13 (c) Spirit lamp

## The Bunsen burner

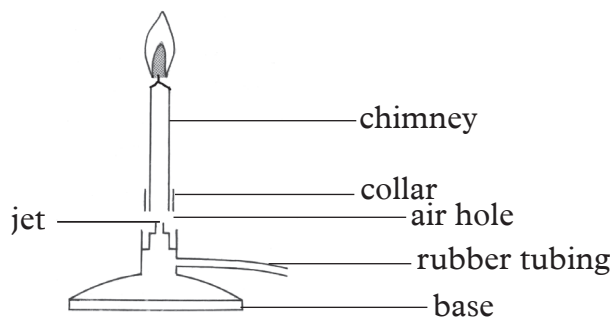
### Activity 1.8

Your teacher will provide you with a Bunsen burner for you to observe.

1. Look at the Bunsen burner keenly. Which parts can you see?
2. Where is the rubber pipe connected to and why?
3. Practice removing and fitting the rubber pipe onto the jet
4. Can you observe some metal ring on the metallic cylinder? Try to unscrew it. What can you see? What is its importance?
5. Draw the Bunsen burner in your notebook and label the various parts.

### The Facts

A German scientist, **Robert Wilhelm Bunsen** invented the Bunsen burner in 1854. A **Bunsen burner** is the most preferred source of heat in the laboratory. A bunsen burner consists of the following parts:



*Fig 1.14 The major parts of a Bunsen burner*

### Functions of the different parts of the Bunsen burner

1. **Chimney** - is a hollow metallic cylinder with an air hole near its lower end. It is designed to raise flame to a suitable height for heating.
2. **Collar** - is a metal ring at the base of the chimney. The diameter of the collar is slightly bigger than that of the chimney so that the chimney can just fit into it. It regulates the amount of air entering the burner by opening and closing the air hole.
3. **Base** - is made of thick metallic material into which a small hollow metal with a jet is fitted. It supports the burner so that it does not topple.

The Bunsen burner is usually connected to an external source of laboratory gas through a rubber tube. The gas is supplied consistently and the size of the flame is controlled by the size of the air hole. Air mixes with gas if the air hole is open. The size of the Air hole is adjusted by the collar. This way, the temperature of the flame can be altered.

## How to light a Bunsen burner

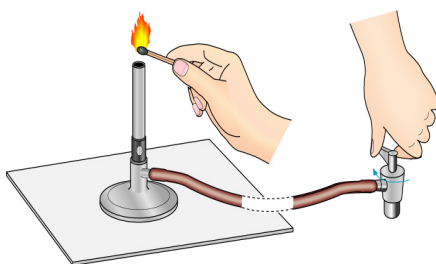
**Caution!** The process of lighting the Bunsen burner should be carried out with extreme caution to avoid unnecessary accidents!

### Activity 1.9

#### *Lighting a Bunsen burner*

1. Connect the rubber tubing to the gas supply and the Bunsen burner. Ensure that the tubing is well fitted on both ends.
2. Make sure that the collar is in position so that the air holes are nearly closed. This will ensure that the flame is at its coolest and visible once the gas is ignited.
3. Before turning on the gas, light your matchstick and slowly run it up the side of the chimney, until it ignites the gas (This is done for safety). Once the flame is lit, put off the matchstick.

#### **Safety precautions when lighting a Bunsen burner**



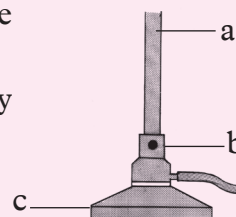
*Fig 1.15 Lighting a Bunsen burner*

1. Ensure that you have a clean working area and a fireproof table.
2. Know where the safety equipment are located and how to use them.
3. Make sure there are no cracks in the rubber tubing, gently squeeze the tubing along the entire length and bend it at several places while you look carefully for cracks. If you see any, replace the tubing.

**Caution;** remember to close the air hole before you ignite the Bunsen burner to avoid **striking back**. Striking back occurs when excess air enters the chimney leading to some weird noise!

## Check your progress 1.2

1. Why do you think it is important to know the locations and operations of all safety equipment in the laboratory?
2. While in the laboratory, a Secondary one student accidentally spills a certain chemical on her hand. She immediately feels a burning effect. What action would you suggest to her?
3. What is the first action a student should take before attempting any experiment in the laboratory?
4. What do you observe when you unscrew the chimney from the base plate of a Bunsen burner?
5. What is the function of the parts labelled a, b and c?



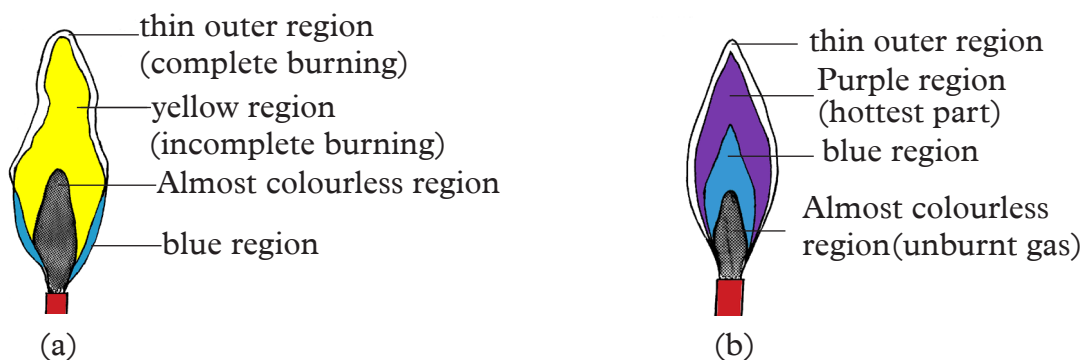
## Flames of the Bunsen burner

### Activity 1.10

1. Let one student lead your group in lighting the Bunsen burner with the air hole closed. Ask for assistance from the teacher if you are still unable to light it. Explain the features of the flame produced in terms of:
  - (a) The colour
  - (b) The shape
  - (c) Smoke produced (if any)
  - (d) Amount of light given out
  - (e) Sound produced if any
2. Using a test tube holder, hold a test tube briefly on the flame and note down your observations.
3. Draw and label a sketch of the flame showing the various zones.
4. Now carefully open the air hole and repeat the above procedure. Draw this flame in your note book.
5. Compare the flames you drew with those in the chart provided by your teacher. Identify the flames.

### The Facts

A Bunsen burner produces two types of flames. When the air hole is closed, no air enters the chimney. The flame produced is bright yellow, large and unsteady. This flame gives out light and is described as **luminous flame**. It gives out light because of the unburnt carbon particles in the flame. The particles are due to incomplete combustion resulting from insufficient air oxygen. These unburnt carbon particles become white hot and produce light. Thus the white-hot carbon particles are responsible for the luminous nature of the flame. They later form black soot which makes the apparatus dirty (Sooty flame).



*Fig 1.16. Parts of (a) Luminous flame (b) Non-luminous flame*

Therefore, a luminous flame has four zones namely:

- The blue region
- Yellow region
- Almost colourless region
- Thin outer region

When the air-hole is open, a lot of air enters the chimney and mixes with the laboratory gas. The mixture burns more quickly and completely. The flame given out is pale-blue and is called **non-luminous flame**. This is because it does not give out much light. Sometimes, it is not easily noticeable.

Non-luminous flames are usually **very hot**. They do not give off smoke i.e. it is non-sooty hence it is the most preferred flame for heating in the laboratory.

*Determining the type of flame that produce most heat*

**Activity 1.11**

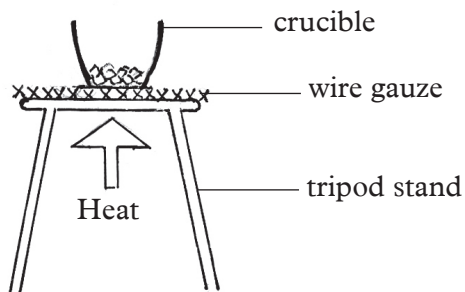
*In groups,*

**Apparatus and reagents**

Bunsen burner flame, beakers, ruler, measuring cylinder, water tripod stand, wire gauze.

**Procedure**

1. Light a Bunsen burner and adjust the collar to produce a luminous flame.
2. Place the tripod stand with wire gauze over it.
3. Measure 50 cm<sup>3</sup> of water and pour it into a beaker, place the beaker on the tripod stand.
4. Heat the water in the beaker and record the time it takes to boil.
5. Repeat the experiment using 50 cm<sup>3</sup> of water in an identical beaker and heat with the non-luminous flame of the same Bunsen burner. In each case observe the part of the beaker that was in contact with the flame. What can you see?



*Fig 1.17: Heating using a Bunsen burner flame*

### Study Question

1. Which of the two water samples took a shorter time to boil?
2. What did you observe at the bottom of each beaker?
3. What type of flame would be suitable for heating. Give reasons for your answer.

### The Facts

A **non-luminous** flame is **hotter** than a luminous flame. It also **does not produce soot** that would blacken the apparatus. **Luminous flame** on the other hand produces **less heat**. It also **produces soot** that blackens the apparatus. The **non-luminous** flame is hence normally preferred for **heating** in the laboratory. Luminous flames such as that of candle flame or lantern lamps are used for **lighting** as well.




*Table 1.2 State the differences between luminous and non-luminous flames*

Luminous flame	Non-luminous flame



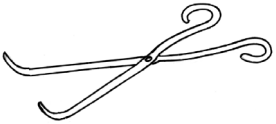
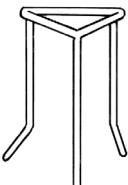
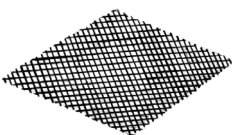
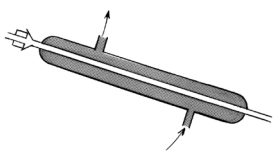
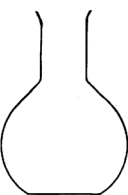

### Other laboratory apparatus

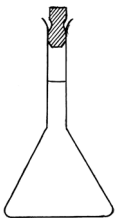


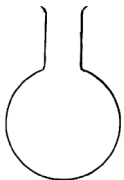

Apart from the apparatus discussed above. There are other laboratory apparatus that are commonly used.

*Table 1.3 Other commonly used laboratory apparatus*

Name of apparatus	Diagram	Use
Conical flask		Heating liquids, swirling, filtrations
Gas jar		Collection of gases
Evaporating dish		Used in evaporation to separate solutes from solvents



Name of apparatus	Diagram	Use
Deflagrating spoon		Used when burning solid substances like phosphorous
Spatula		For scooping solid chemicals especially when weighing
Pair of tongs		For grasping and lifting materials including hot ones
Tripod stand		For supporting beakers while heating liquids
Wire gauze		Placed between a beaker and tripod stand during heating of solutions. It ensures even distribution of heat
Liebig's condenser		For fast condensation (conversion of steam to liquid) to take place
Flat-bottomed flask		For heating liquids and to contain chemicals
Thistle funnel		Used when adding liquids to existing system of apparatus

Name of apparatus	Diagram	Use
Volumetric flask		Used to prepare accurate volumes of solutions.
Filter funnel		For carrying out filtration. Used together with a filter paper.
Teat pipette		For measuring volumes of solutions dropwise.
Round-bottomed flask		For heating of solutions, contain chemicals and distillation
Beaker		For holding liquids or solutions

### Check your progress 1.3

- Point out two apparatus that can be used for heating in the laboratory a part from the bunsen burner.
- What is the name of the flame produced when the air-hole of the Bunsen burner is open?
- Explain briefly why the luminous flame produces light while the non-luminous flame does not.
- Complete the table below.

Apparatus	Uses
	Transferring accurate volumes of liquids
Volumetric flask	
Ignition tube	
	Separating immiscible liquids

## 1.4 Separation of mixtures and compounds

### Activity 1.12

In pairs;

1. Put some bean and maize seeds in separate containers.
2. Now, mix the beans and maize in one container.
3. Try separating the maize from the beans seeds.
  - Is it possible?
  - If it were a mixture of sugar and sand, would you be able to separate them?
  - What about a mixture of sand particles from water, would you separate them?
  - What does this tell you about mixtures?
  - What about pure substances?

### The Facts

Many substances around us are mixtures. Examples of mixtures are air, tap water, and milk. Can you name other mixtures? In everyday life, we often need to separate mixtures to obtain pure substances. This applies in cases where only pure substances are required.

### Methods of separating mixtures

#### Work to do

1. Imagine you have poured some water in a basin and left it to warm for a while in sunlight. Suddenly, sand blows over it before you take a shower.
  - How will you ensure that the water is clean again before taking the shower?
2. Find out other methods that can be used to separate mixtures. Write them down in your notebook

### The Facts

Separation of materials is important in our everyday life. This is because sometimes we can only get the desired results when using the materials in their non-combined states.

Methods used to separate mixtures depend on the physical properties of the components. Such properties include solubility, density, boiling point and miscibility.

Some of the methods commonly used to separate mixtures include:

- Filtration
- Decantation
- Simple and fractional distillation
- Paper chromatography
- Crystallisation
- Evaporation
- Sublimation
- Centrifugation
- Magnetic separation
- manual sorting

### (a) Filtration

#### Work to do

#### *Answer these questions*

- 1 While at home how do you prepare tea?
- 2 How do you separate the tea from the tea leaves you used?

#### The Facts

Filtration is the most commonly used method in our everyday life. The filtering apparatus depends on the size of the particles to be obtained.

#### Activity 1.13

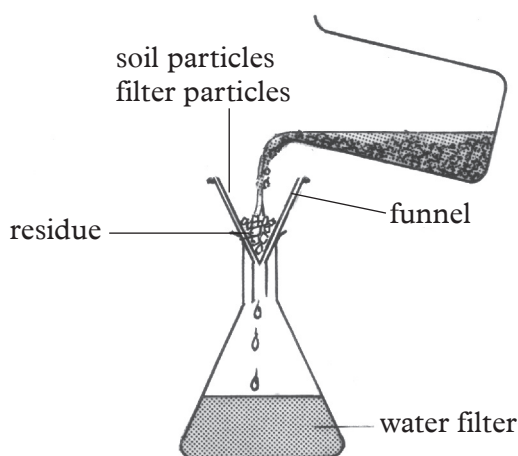
In groups;

#### *Apparatus and reagents*

Beaker, conical flasks, filter paper and funnel, soil and water mixture

#### *Procedure*

1. Fold the filter paper to form a quadrant, and then open it up into a hollow cone.



*Fig 1.: 18 Filtration*

2. Wet the paper to make it stick on the funnel.
3. Place the funnel on the conical flask.
4. Stir the mixture of soil and water and pour it into the funnel fitted with the filter paper. What happens?

### **Study Questions**

1. Describe the contents left on the filter paper and those in the conical flask.
2. What name do we give to the content on the filter paper and those in the conical flask?

### **The Facts**

After filtration, the liquid which passes through the filter paper is called the **filtrate** while the solid that remains on it is called the **residue**.

### **(b) Decantation**

#### **Activity 1.14**

In groups

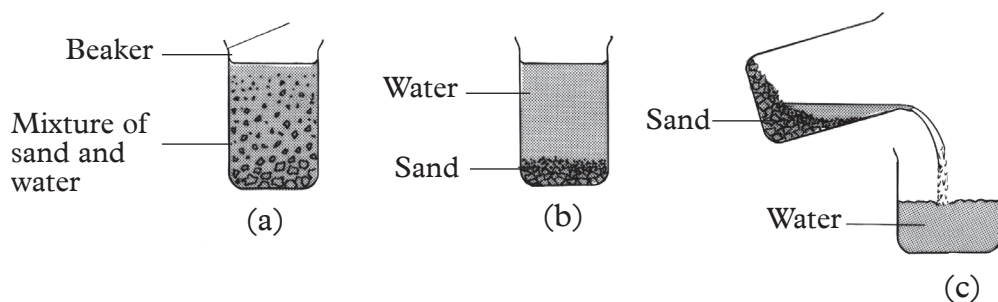
#### **Apparatus and reagents**

Two beakers, stirring rod, sand and water.

#### **Procedure**

1. Place some sand in a beaker.
2. Add water and stir.

3. Allow the sand to settle at the bottom of the beaker. Carefully pour off the water to the second beaker by tilting the beaker containing water and sand.



*Fig 1.19. Decantation steps*

### The Facts

Decantation is a process of separating a mixture of solid and liquid or two immiscible liquids by allowing them to settle and separate by gravity. Once the mixture components have separated the lighter liquid is poured off leaving the heavier liquid or solid behind. Typically a small amount of the lighter liquid is left behind.

### *(c) Use of a separating funnel*

#### Work to do

Suppose you mistakenly added cooking oil to water in a beaker:

- Illustrate how you would separate cooking oil from water.
- Is the method you have used convenient?
- Is there a special apparatus that can be used to separate the two components?

When a mixture of cooking oil and water is separated by decantation, the cooking oil obtained has some water in it. A better method of separating these two is by use of a separating funnel.

## Activity 1.15

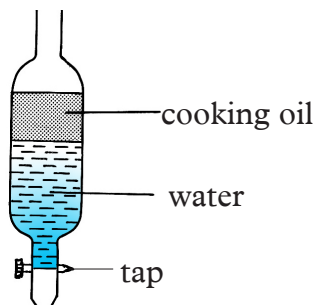
### *In groups*

### **Apparatus**

Separating funnel, two beakers, kerosene, water.

### **Procedure**

1. Place the mixture of kerosene and water in to a separating funnel.
2. Leave the mixture for sometime until there is a clear dividing line between the two liquids.



*Fig. 1.20 Using a separating funnel*

3. Open the tap and allow the lower layer of the mixture to run out into an empty beaker. Close the tap once this layer reaches the tap.
4. Run out a small quantity of some liquid and discard it. This might be a mixture of the two liquids.
5. Open the tap again and run the top layer of the mixture into another empty beaker.
  - You now have separated the two liquids.

### **The Facts**

A mixture of water and cooking oil forms two layers. The top layer is that of cooking oil while the bottom one is that of water. The two liquids cannot form an homogenous mixture. They therefore are called **immiscible** liquids. Liquids that form a homogenous mixture are called **miscible** liquids. Cooking oil floats on water because it is less dense than water.

### **Check your progress 1.4**

1. What other substances can you separate using this separating funnel?
2. Write down a procedure on how you can separate the substances you mentioned.
3. What did you note when you were heating the distilled water and the salt solution?
4. What about the boiling temperature, was there a difference? Why do you think this is so?

### (d) Simple distillation

#### Work to do

##### *In groups*

1. Pour distilled water in beaker, measure the temperature of the water using a thermometer and record. Allow the water to boil then measure the temperature once again and record
2. Do the same for a solution of water and salt. Allow the mixture to boil then record the boiling temperature.
3. Tabulate your results.

#### Activity 1.16

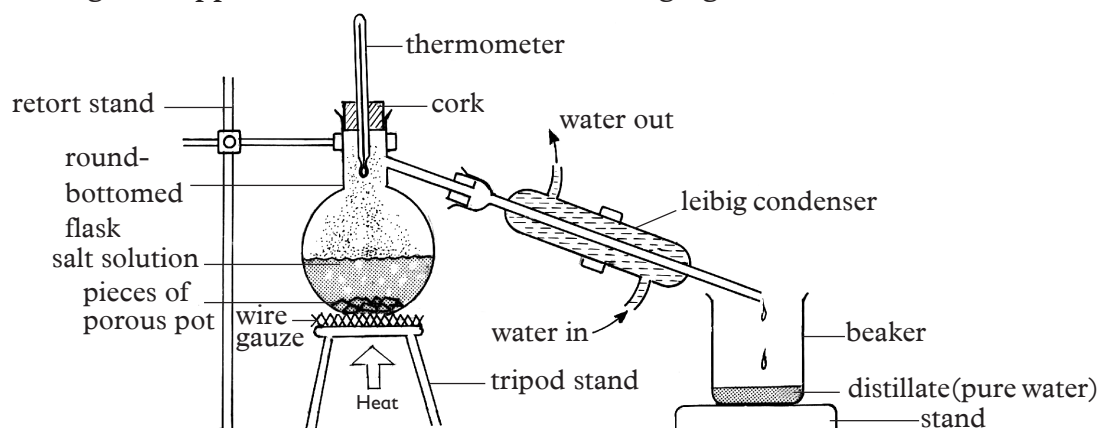
##### *In groups*

##### *Apparatus and reagents*

Round-bottomed flask, Bunsen burner, retort stand, condenser, wire gauze, clamp, pieces of porous pot, thermometer, beaker, common salt and water

##### *Procedure*

1. Prepare some salt solution by mixing salt and water.
2. First try to separate the components by decantation method. Are you able to separate salt from water?
3. Pour the solution into the round-bottomed flask and add pieces of porous pot.
4. Arrange the apparatus as shown in the following figure.



*Fig 1.21 Simple distillation apparatus*

#### Work to do

1. What is the use of the thermometer and the pieces of porous pot?
2. What do you think would happen if directions of water in the condenser were reversed?
3. What is the name of the liquid collected in the beaker?



## The Facts

Simple distillation is a method of separating miscible liquids whose boiling points are significantly different from each other or to separate liquids from solids or non volatile components. In simple distillation, a mixture is heated to change the most volatile component from a liquid into vapour. The vapour rises and passes into a condenser (which is cooled by running cold water around it) then collected. During distillation evaporation and condensation takes place at the same time but in different apparatus

### (e) Fractional distillation

#### Activity 1.17

##### In groups

##### Apparatus and reagents

Round-bottomed flask, condenser, fractionating column, Bunsen burner, wire gauze, glass beads, thermometer, beaker, ethanol and water

##### Procedure

1. Put a mixture of ethanol and water into a round-bottomed flask and arrange the apparatus as shown in the following figure.

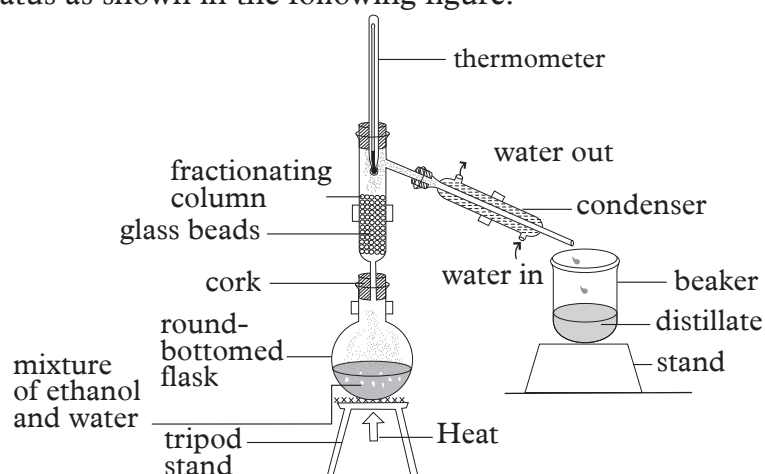


Fig. 1.22 Apparatus for fractional distillation

#### Work to do

1. What are the functions of the glass beads in the fractionating column?
2. How would you test for the first distillate if you had a burning splint and a sample of the distillate?

#### My Health my life

*Yielding a higher pure sample of the volatile component of the mixture ethanol is found in alcoholic beverages. Consumption of alcohol is not a healthy habit.*

### The Facts

When you try to separate a mixture of ethanol and water by simple distillation, the first distillate will not be pure ethanol. It will contain portions of water. An efficient method therefore would be **fractional distillation**. Fractional distillation is used when the boiling points of the components of a mixture are close to each other. A fractionating column is used to separate the components. In fractional distillation a mixture is heated and vapour rises and enters the fractionating column. As it cools it condenses on the packing materials of the column. The heat of the rising vapour causes this liquid to vapourise again moving it along the column and eventually yielding a higher pure sample of the more volatile component of the mixture. Ethanol has a lower boiling point than water. It thus boils and condenses first. Fractional distillation is also used industrially to separate the components of crude oil and also those of air.

### (f) Paper chromatography

#### Activity 1.18

##### *In groups*

##### *Apparatus and reagents*

Beaker, filter paper, black ink, droppers, propanone and teat pipettes.

##### *Procedure*

1. Place filter paper on a beaker.
2. Use a teat pipette to put a drop of black ink at the centre of the filter paper.
3. Add propane dropwise using a different pipette, waiting till each drop has stopped spreading.
4. Repeat until the outermost boundary is near the edge of the filter paper.
5. Leave the paper to dry and compare the bands formed with those of other pairs.

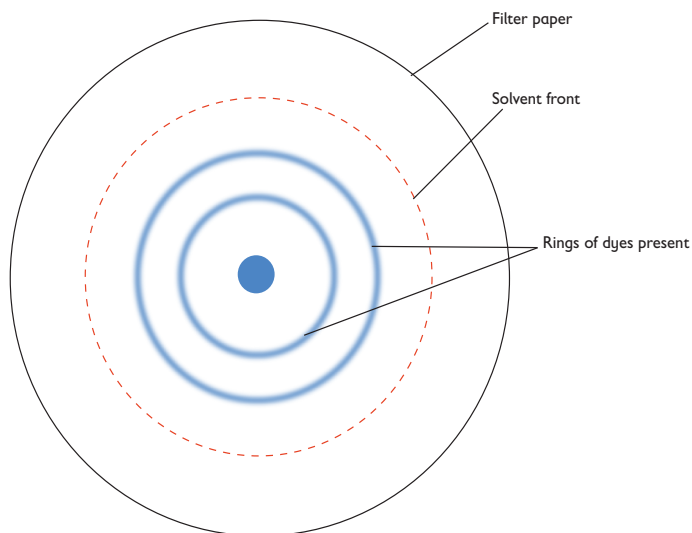
### The Facts

Paper chromatography is used to separate mixtures of coloured compounds through adsorption. Mixtures that are suitable for separation by chromatography include inks, dyes and colouring agents in food. Simple chromatography is carried out in a paper placed upright in a suitable solvent. As the solvent soaks up the paper, it carries the mixture with it. Different components of the mixture will move at different rates. This separates the mixture out.

Two factors are necessary for the chromatogram to form see fig 1.23 below. These are:

- (i) The dye must be soluble in the solvent used.
- (ii) The absorbent material must retain the dyes.

The degree of solubility in propanone is different for the dyes in the ink. The filter paper also retains the dyes at different rates. The dye immediately after the **solvent front** is the most soluble. It is also the least retained. The solvent front is the furthest point reached by the solvent on the chromatography.



*Fig 1.23 A chromatogram*

### *(g) Crystallisation*

#### Work to do

1. Find out from the dictionary what a crystal is.
2. Using reference materials find out the meaning of a saturated solution.

#### The Facts

A saturated solution is one that cannot dissolve any more of the solute at a given temperature and contains undissolved solute. you can make crystals from a saturated solution. Hot water will dissolve more sodium chloride than cold water.

## Activity 1.19

### *In groups*

#### *Apparatus and reagents*

Beaker, sodium chloride, stirring rod and water.

#### *Procedure*

1. Put  $100\text{cm}^3$  of water in a beaker.
2. Add sodium chloride a little at a time while stirring well with a glass rod until no more can dissolve.

**Note:** One can tell it is saturated when undissolved salt settles down even after vigorous stirring.

3. Filter off the undissolved salt. The filtrate is called **a saturated solution**

### *The Facts*

When saturated solutions lose water, a solid is left behind. The solid has a regular shape. Such a solid is called **crystal**. The process of obtaining crystals from a solution is called **crystallization**.

## Activity 1.20

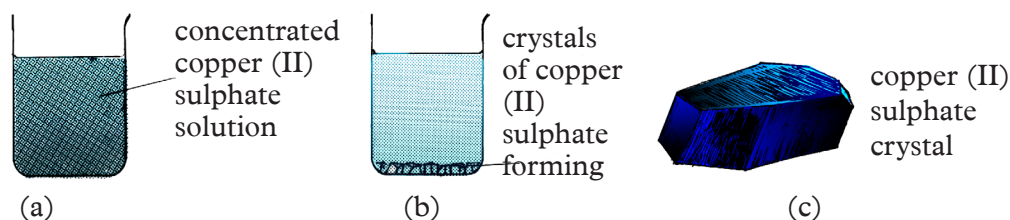
### *In groups*

#### *Apparatus and reagents*

Beaker, copper (II) sulphate, water, glass rod.

#### *Procedure*

1. Prepare about  $50\text{ cm}^3$  of a saturated solution of copper (II) sulphate solution using the method in activity 1.19.
2. Put the filtrate in a beaker and cover it with a filter paper pierced with a few holes.
3. Leave the content of the beaker undisturbed for 2-3 weeks.



*Fig 1.24 Preparing crystals of copper (II) sulphate*

### *Study questions*

What do you observe after the third week?

## The Facts

The solid substances with regular shapes are called crystals. The colour of the solution changed from deep blue in colour to pale blue due to a reduction in concentration of the solution.

Therefore, **crystallization** is a separation process based on the different solubility of a compound in a solvent at a certain temperature and pressure. A change of these conditions to a state where the solubility is lower will lead to the formation of a crystalline solid.

### (h) Evaporation

#### Activity 1.21

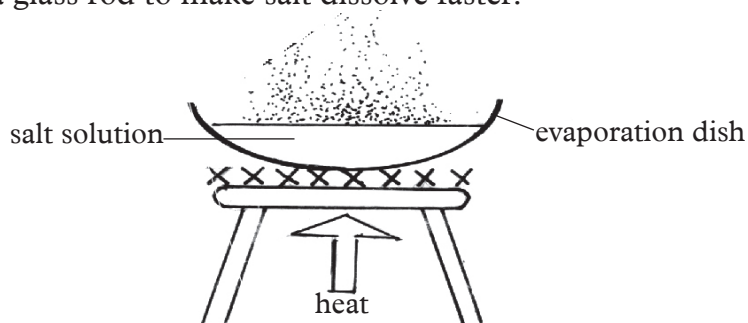
##### *In groups*

##### *Apparatus and reagents*

Beaker, Bunsen burner, conical flask, filter funnel, glass rod, filter paper, wire gauze, water, sand, salt, tripod stand and evaporating dish.

##### *Procedure*

1. Place the mixture of salt and sand in a beaker half filled with water.
2. Stir with a glass rod to make salt dissolve faster.



*Fig. 1.25 Apparatus for carrying out Evaporation*

3. Pour the mixture into a conical flask through a filter funnel fitted with a filter paper.
4. Put the filtrate into an evaporating dish and heat gently. Evaporate to dryness.

#### Work to do

1. Name what remains in the filter paper and on the evaporating dish.
2. What are the two methods used in this activity?

## The Facts

**Evaporation** is the process by which water and other liquid changes from a liquid state to vapour (or gas state). Evaporation can be used to separate a mixture (solution) of a soluble solid and a solvent. The process involves heating the solution until the solvent evaporates leaving behind the solid residue.

### Further activity

Write a report on the findings of a similar experiment involving separation of sugar and sand mixture and present it to the class.

The report should have these parts: aim, apparatus and reagents, labelled drawing of the apparatus, procedure, results and conclusion.

### (i) Sublimation

#### Activity 1.22

##### *In groups*

##### *Apparatus and reagents*

Sodium chloride salt, ammonium chloride, Bunsen burner, boiling tube and beaker

##### *Procedure*

1. Mix sodium chloride and ammonium chloride evenly in a beaker.
2. Transfer the content of the beaker into the boiling tube.
3. Heat the mixture until there is no further change (Ensure that the boiling tube is tilted/slanting when heating)
4. Allow the boiling tube to cool while still in a slanting position.

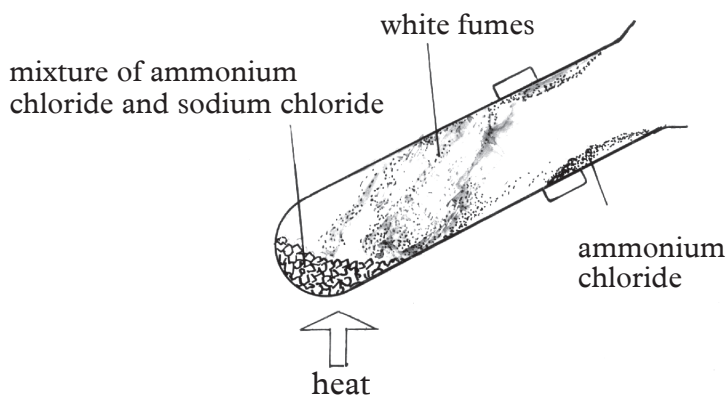


Fig 1.26 Sublimation

### Work to do

1. What observation do you make when you start heating?
2. What observation do you make after cooling the boiling tube?

### The Facts

Sublimation is a chemical process where a solid turns into a gas without going through a liquid state. In a mixture where one of the components can sublime, the method can be used to separate them. **Ammonium chloride** undergoes sublimation while **sodium chloride** does not. The white fumes seen are of ammonium chloride. When cooled the fumes undergo deposition to form ammonium chloride sublimate. The solid left at the bottom of the boiling tube is sodium chloride.

**Other methods of Separation include:**

#### (i) Centrifugation

This is a process by which a centrifuge is used to separate components of a complex mixture. The centrifuge separates a heterogeneous mixture of a solid and a liquid by spinning it at a high speed. The solid precipitate settles at the bottom of the test tube and a solution called the **supernatant** is formed. Centrifugation is used in separation of urine components in hospitals.

#### (ii) Magnetic separation

### Work to do

Your younger brother plays with some nails and unfortunately he drops them in a container of cooking flour.

- (a) How would you remove the nails?
- (b) What could be the effect of feeding on foodstuff contaminated with metallic materials?

*Consumption of food contaminated with metallic materials can lead to poisoning.*

### The Facts

Magnetic separation is the process whereby magnetically susceptible materials are extracted from a mixture using a magnetic force.

#### (iii) Manual Sorting

### Work to do

How will you separate a mixture of maize and beans?

Manual sorting is a separator method that involves picking substances that are usually big enough to be sorted by hand.

### Check your progress 1.5

- An aunt of a senior one student who stays in Juba has been complaining of the water they fetch from the village borehole as being salty.
  - What do you think is the composition of the water?
  - What advice would you have given her?
- Which two methods can you use to separate a mixture of salt and water?
  - Which of the methods you have suggested is the most appropriate?
  - Name another material that can be used in place of glass beads in simple distillation?
- What are the advantages of chromatography?
- Apart from solving rape cases, in which other areas can we apply chromatography?
- Match the items with their separation method.

Tea leaves and tea	Sorting
Pulses and stones	decantation
Mud and water	Filtration

- What is saturation? How would you obtain a crystal from a saturated solution. Illustrate.
- Write down a procedure of how you would separate sand from sugar.

### Activity 1.23

- In pairs, classify the following substances as either compounds or mixtures. Sodium chloride, sugar solution, water, magnesium oxide, carbon monoxide, copper oxide, copper nitrate.
- Identify the elements forming each of the mixtures or compound listed above in a table like one below. The first one has been done for you.

Substance	Compound or mixture	Components of the mixture or compound
Sodium chloride	Compound	Sodium and chlorine
Sugar solution		
Water		
Magnesium oxide		
Carbon monoxide		
Copper (II) oxide		
Copper (II) nitrate		



## 1.5 Application of separation of mixtures and compounds

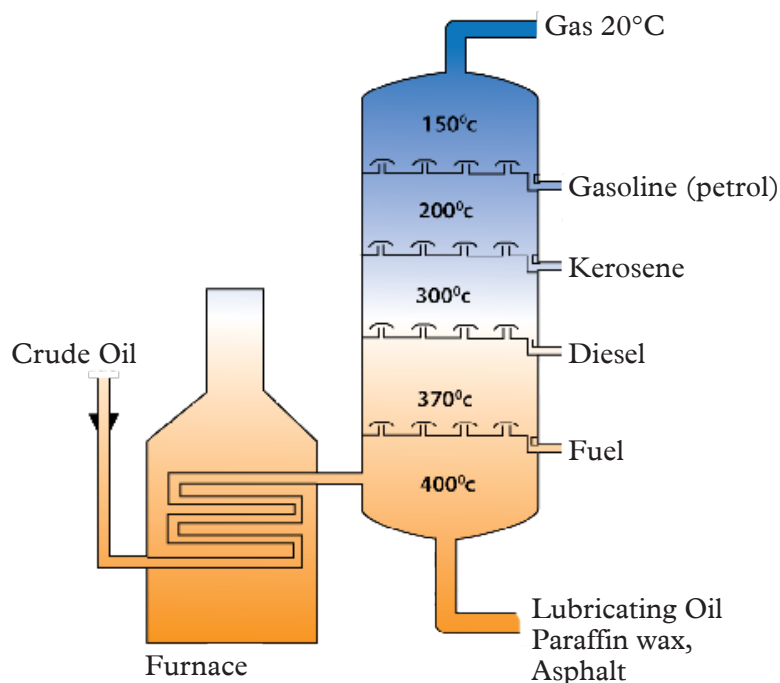
### Activity 1.24

You will be provided with charts, diagrams and computer animations of the fractional distillation process.

1. In your study groups discuss the process of fractional distillation of crude oil and liquid air.
  - What are the uses of the products formed?
2. Write report on your findings and present it to the rest of the class.

### (a) Fractional distillation of crude oil

Crude oil is a thick black liquid with a strong smell. Unless its components are separated, crude oil does not have much use. During fractional distillation at a refinery, the mixture of hydrocarbons is sorted out into groups or individual hydrocarbons called **fractions**. A fractionating column is used for separating the mixture.



*Fig. 1.27 Fractional distillation of crude oil*

The crude oil is first heated up in a furnace. As it is heated, the small molecules boil off first. They enter the column as a gas. The fractionating column is hot at the bottom and cooler at the top. The gas molecules then condense. The larger hydrocarbons have higher boiling points. This means that the larger hydrocarbons, with the high boiling points, turn back to liquids easily nearer the bottom. At high

temperatures, the hydrocarbons are in form of gases. They rise up the column. The different fractions condense and are collected at different levels as shown in Fig 1.2 above.

As we have said Crude oil is a complex mixture of mainly hydrocarbon compound molecules. What are some of the properties of these compounds that make up crude oil?

**Table 1.4 Some properties of components of crude oil**

Names of fractions	C atoms in the molecule	Boiling range in °C	Uses of the fraction
Fuel Gas, LPG, Refinery Gas	1 to 4	-160 to 20°C	Methane gas fuel, C <sub>3-4</sub> easily liquefied, portable energy source bottled gas for cooking (butane), higher pressure cylinders (propane)
Gasoline, Petrol	5 to 11	20 to 60°C	Easily vaporised, highly flammable, easily ignited, carfuel
Naphtha	7 to 13	60 to 180°C	Not good as a fuel, but valuable source of organic molecules to make other things, cracked to make more petrol and alkenes
Paraffin, Kerosene	10 to 16	120 to 240°C	less flammable than petrol, domestic heater fuel, jet fuel
Diesel oil, Gas oil	15 to 25	220 to 250°C	Car and larger vehicle fuel
Fuel and lubricating Oils and Waxes	20 to 70	250 to 350°C	Not so easily evaporated, not as flammable, safe to store for central heating oil, quite viscous (sticky) and can also be used for lubricating oils, clear waxes and polishes
Bitumen	over 70	over 350°C	Forms a thick, black, tough and resistant adhesive on cooling, used as waterproofing material and to stick rock chips on roofs or road surfaces

The chemical properties of each substance in the mixture does not change. This means crude oil can be separated by physical methods, in this case fractional distillation, because they have different boiling and condensation points.

The most volatile fraction, i.e. with the lowest boiling point, boils or evaporates off first and goes to the top of the column as seen in table 1.3.

The rest separate out according to their boiling point so that the highest boiling fraction, i.e. the less volatile with higher boiling points, tend to condense more easily lower down the column.

The bigger the molecule, the greater the intermolecular forces, so the higher the boiling point. Chemical bonds are not broken in the process, only the intermolecular force of attraction.

## Uses of products of fractional distillation

1. The refinery gas fractions, under pressure, are conveniently pumped to burner systems to be used for cooking and heating. They are easily ignited and are explosive.
2. **Vehicle fuels** are liquid for compact and convenient storage. They must be easily vaporised to mix with air in the engine prior to ignition. The ease of vaporisation does however make them flammable.
3. **Paraffin** and **kerosene** are less flammable and safer, but not as easily ignited. They are not too viscous to pump not very volatile and so not as flammable and dangerous as petrol or diesel and therefore used for **domestic use purpose**.
4. **Lubricating oil** are quite viscous to stick onto surfaces. Smaller molecules might be more runny but they would evaporate away. It is also water repellent and helps reduce corrosion on moving machine parts.
5. **Candle wax** is used to make candle. The heat from the flame is sufficient to vaporize the hydrocarbons to burn them.
6. **Bitumen** is a water repellent solid at room temperature but is readily melted (sometimes too easily in hot weather). Used as base for a road chipping top surface or sometimes directly. It is also used to waterproof roofing felt.

When crude oil has been distilled into useful fractions it is found that the quantities produced do not match the ratio required for commercial purposes. The need for petrol and diesel for motor vehicles is rising. Larger molecules which do not make good fuels or have other uses are in plenty while fuel oil, naphtha and bitumen in crude oil exceed demand.

Also, alkenes are not found in crude oil but are one of the most valuable types of organic molecule in the chemical industry. They are used to make polymers (plastics) or ethanol (an alcohol).

The two deficiencies are remedied by the process of cracking, which converts big molecules into useful smaller ones.

**Cracking** is done by heating some of the less used fractions to a high temperature vapour and passing over a suitable hot catalyst. The cracking reaction is an example of thermal decomposition - (a reaction that breaks down molecules into smaller ones using heat). The main products from cracking alkanes from oil are smaller alkanes (for petrol or diesel) and alkenes (for plastics).

The cracking involves breaking single carbon-carbon bonds to form the alkanes (saturated hydrocarbons) and alkenes (unsaturated hydrocarbons) products.

### (b) *Fractional distillation of liquid air*

Air is a mixture of gases, which include nitrogen, oxygen, carbon dioxide, noble gases and water vapour. Fractional distillation of air involves first removal of water vapour, dust particles and carbon dioxide. If water vapour and carbon dioxide were not removed, they would form solids at low temperatures and block pipes.

Next the air is compressed at about 200 atmospheres. This makes the air hot. It is then allowed to expand through a jet, which it gets very cold and some turns into liquid. Compression and expansion are repeated several times and each time air gets colder. By the time it reaches  $-200^{\circ}\text{C}$ , all the gases remaining namely nitrogen, oxygen and argon have become liquid, except neon and helium. The two are removed.

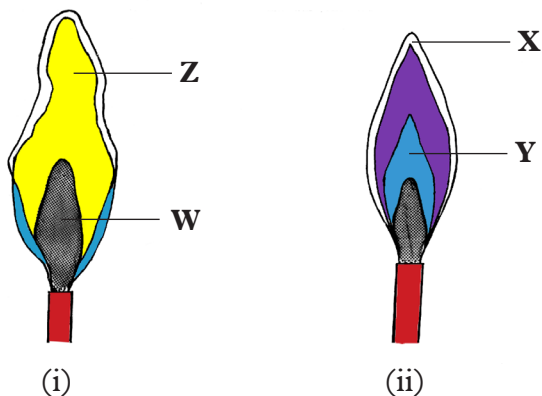
Since nitrogen and oxygen have different boiling points, they are separated by fractional distillation. When liquid air is warmed slowly, liquid nitrogen which has a lower boiling point ( $-196^{\circ}\text{C}$ ) distils first and can be stored under pressure in steel cylinders. The remaining liquid is very rich in oxygen. On further heating oxygen whose boiling point is  $-183^{\circ}\text{C}$ , distils leaving argon which has a higher boiling point of  $-186^{\circ}\text{C}$ . Once separated the two gases are stored and sold commercially in steel cylinders.

#### Check your progress 1.6

1. (a) What is the purpose of the fractional distillation of crude oil?  
(b) What is the basic principle that is used in fractional distillation.  
(c) Describe how crude oil is separated into different componets.  
(d) How can the process of fractional distillation be demonstrated in the laboratory. Explain using a diagram.
2. Using a table, compare the difference between mixtures and compounds.
3. Give two conditions needed for cracking.
4. State two applications of fractional distillation.

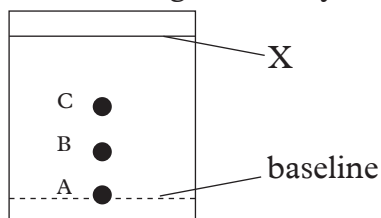
## Unit Test 1.1

1. (a) Identify the flames shown below.



- (b) Name the parts labelled **X** and **Y**, **Z** and **W**.
- (c) State the differences between luminous and non-luminous flame.
- (d) Describe an experiment to show the parts of the flame that has unburned gas.
2. Explain why most laboratory apparatus are made of glass.
3. Which piece of laboratory apparatus would be most suitable for each of the following activities?
- Holding 50 cm<sup>3</sup> of boiling water.
  - Melting a crystal over a Bunsen burner.
  - Pouring 50 cm<sup>3</sup> of acid from one container to another.
  - Measuring exactly 30 cm<sup>3</sup> of water.
  - Removing substances from a reagent bottle.
  - Weighing 100 grams of sodium chloride.
4. Provide appropriate answers to the following questions.
- When should safety goggles be worn?
  - How should we handle and dispose broken glassware.
  - If you accidentally spill water near electrical equipment, what should you do?
5. (a) What precautions should you take when heating solutions in a test tube?
- (b) It is always appropriate to dispose chemicals by flushing them down the sink. Explain.
- (c) What precautionary steps should you take when performing an experiment that involves release of poisonous gases?

6. Name some of the things that appear as pure substances but are actually mixtures.
7. Given the following substances: copper, common salt and tap water. Classify them into pure substances and mixtures.
8. You and your friends, carried out an experiment, whereby you mixed water and sea water. Which method would you use to separate the two? Name other substances that can be separated by the method you mentioned
9. Suggest an appropriate method that can be used to separate cream from milk.
10. If you mistakenly add salt to boiling water instead of sugar while preparing tea, what would you do to obtain your salt back?
11. Which of the following methods can be used to separate iodine from sand?
  - (a) Evaporation
  - (b) Fractional distillation
  - (c) Sublimation
  - (d) Filtration
12. Account for this statement: "Milk is a pure substance".
13. The figure below shows a chromatogram of a dye.



- a) Name the line labelled X.
  - b) Was the dye a mixture or a pure substance? Explain.
  - c) Name a suitable solvent that can be used to dissolve the dye for a successful separation.
  - d) Give two reasons as to why C moved the furthest distance while A moved the shortest distance.
14. Akong was sent by her mother to buy a packet of salt from a kiosk. On her way back, she tripped and the packet fell down bursting open. She collected the salt together with some soil and small stones. Give a detailed procedure that she could use to obtain clean salt crystals from this mixture.

15. The apparatus below are used to separate water from ethanol.



- Using the apparatus above, assemble using a well labelled diagram, showing how the process is carried out.
  - Label the apparatus correctly.
    - What is the function of the glass beads in the process?
  - What substance do you expect to collect first?
  - Give a reason for your answer in (c) above.
16. Air contains approximately 21% \_\_\_\_\_ and about 0.03% \_\_\_\_\_
17. Your friend tells you that she wants to become a medical doctor. Which two subjects must she score highly so as to pursue her career of choice?
18. Differentiate the following:
- Evaporation and sublimation
  - Fractional distillation and simple distillation.
  - Miscible and immiscible liquids
  - Decantation and filtration
  - Crystallization and centrifugation

19. Briefly explain how the following have contributed to the economy of South Sudan.
- (a) Development of vaccines
  - (b) Manufacture of fertilisers and animal feeds
  - (c) Efficient transport and communication system
20. Assume you visited a milk processing plant in your locality. Write a short report that you would use to make a presentation to the rest of the class on the importance of Chemistry in economic development.
21. An outbreak of a disease whose main symptom is diarrhoea has occurred in a certain village in Juba. Health officers suggest that the outbreak is due to residents drinking contaminated water. With your knowledge of chemistry, what would you advise your friend who lives in that cell?
22. When asked to say the meaning of Chemistry, Secondary 1 learners from Bunge Secondary school gave the following answers:
- Odek A – The study of drugs and chemicals.
  - Mabior B – The study of processes taking place in a laboratory.
  - Achok C – The study of the structure and composition of substances and the way they behave under different conditions.
- Which learner do you think was right? Explain



# UNIT 2

## Particulate nature of matter formulae and chemical equations

Learning outcomes		
Knowledge and understanding	Skills	Attitudes
<ul style="list-style-type: none"><li>Understand particulate nature of matter, formulae and chemical equations</li></ul>	<ul style="list-style-type: none"><li>Investigate practically the effect of heat on matter.</li><li>Deduce the formulae of simple and ionic compounds from the relative numbers of atoms.</li><li>Investigate practically using appropriate specialist equipment.</li><li>Recording results accurately and in an appropriate way.</li><li>Analysis of the result and looking for patterns.</li></ul>	<ul style="list-style-type: none"><li>Take responsibility in group work.</li><li>Appreciate explanations of chemical reactions using chemical equations. Be aware of risk and safety to themselves and others.</li></ul>

### 2.1 The states of matter

#### Work to do

1. Add more water to a glass that is already full of water. What happens?
2. Observe the ice cubes provided by your teacher, how would you describe the ice cubes. What is the difference between the ice cubes and the water in a glass?
3. Blow some air in a balloon and measure its weight. Take another measurement of the balloon in its deflated state. What do you notice?

#### The Facts

All substances that are found in nature are made up of **matter**. Matter is anything that occupies space and has mass.

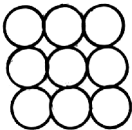
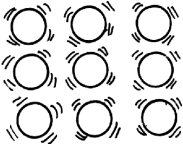

Matter can be put into three different groups, that is:

- **Solids** - for example soil, chalk, salt, sugar, wood and metals.
- **Liquids** - for example water, kerosene, milk and spirit.
- **Gases** - for example air, biogas, oxygen and carbon dioxide.

These three groups are commonly known as **states of matter**. Each of these states of matter have characteristic properties.

The following table gives characteristic properties of the three states of matter.

**Table 2.1 Properties of the three states of matter**

Solids	Liquids	Gases
1. Have fixed shape and volume.	Have fixed volume but occupies the shape of the container.	Have no fixed shape or volume.
2. Have rigid particles which vibrate within fixed positions.	Particles slide past one another more slightly.	Particles move very fast.
3. Cannot be compressed at all.	Can be compressed to a very small extent.	Very compressible.
4. Do not flow at all.	Flow easily.	Flow very easily.
 Solid state	 Liquid state	 Gaseous state

*Fig 2.1. Illustration of the three states of matter*

### Check your progress 2.1

- Name the three states of matter.
- (a) What are some of the things around you that are not matter?  
(b) Why do you think they are not considered to be matter?

## 2.2 Changes of states of matter

### Work to do

- (a) What can you conclude when you wake up and find a lot of water droplets on grass yet it was hot and dry the previous day?  
(b) Does this water remain on the grass the whole day?
- (a) What happens to a candle as it burns?  
(b) What causes the change in 2 (a) above?  
(c) Can the burnt candle be remoulded?
- What happens when wood is burnt in limited supply of air?

## The Facts

Matter can be converted from one state to another.

### Activity 2.1

#### Investigating melting

##### Reagents and apparatus

Bunsen burner, cooking fat, piece of ice, matchbox, glass beaker.

**Caution!** Remember the correct procedure of lighting the Bunsen burner to avoid accidents in the laboratory.

#### Money matters!

Put off Bunsen burner after heating to save gas. Also use the cooking fat sparingly.

#### Procedure

1. Put some ice in a beaker.
2. Place the beaker over a non-luminous flame. Observe what happens to the ice.
3. Repeat procedures 1 and 2 with cooking fat and note down your observations.

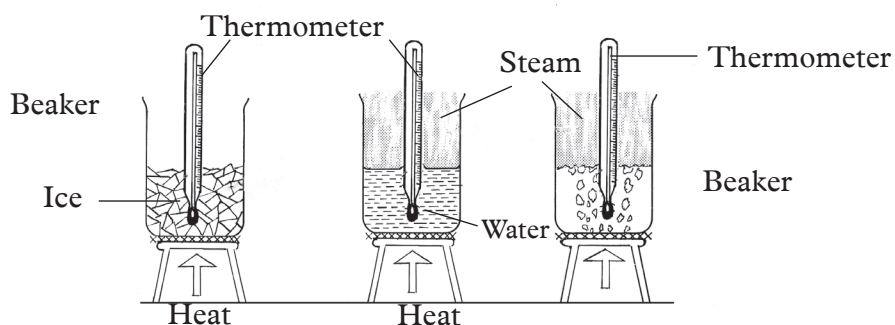


Fig 2.2 Heating ice

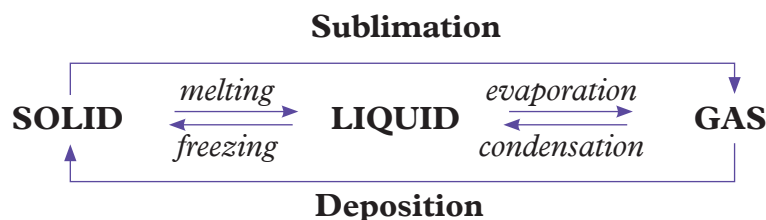
### Work to do

1. At what temperature does the ice change its state?
2. What happens to the cooking fat when placed over the flame?
3. Explain what happens to the fat when placed in cold water.

## The Facts

When some solids are heated they change into liquids. This process is called **melting**. When the liquids are cooled they change back into the solid state. This process is known as **freezing**.

When a piece of ice is heated, it changes into liquid water. The water slowly changes into vapour with continued heating. The process through which water changes state from liquid to gas is known as **evaporation**. When the vapour is cooled, it changes back into liquid form. This process is called **condensation**. It is also possible to change a solid directly into a gas. This is called **sublimation**. However, when a gas changes directly to a solid; the process is called **deposition**.



*Fig 2.3. Illustration of the process involved in the changes of states*

## 2.3 Physical and chemical changes of matter

There are two types of changes that matter can undergo; namely:

- Physical change
- Chemical change

In activity 2.1, when the cooking fat and the piece of ice are heated, no new substances are formed. The processes are also reversible. Such changes are known as **physical changes**. A physical change is also known as a **temporary change**. Some changes lead to the formation of new products. Such changes are irreversible. They are referred to as **chemical changes**. A chemical change is also referred to as a **permanent change**.

### (a) Physical Changes

#### Experiments demonstrating physical changes

#### Activity 2.2

##### *Investigating changes that occur when ice is heated*

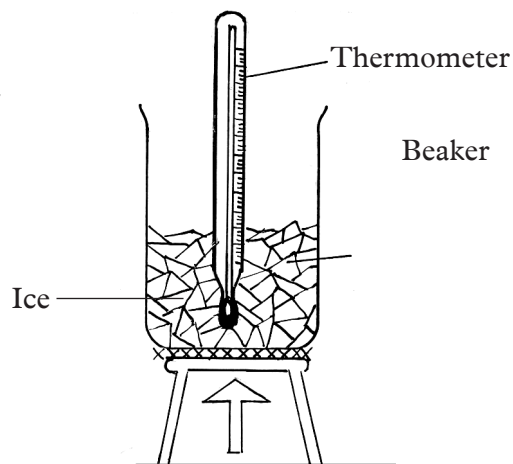
##### **Apparatus and reagents**

Ice, thermometer, beakers, Bunsen burner and tripod stand, wire gauze

##### **Procedure**

1. Half-fill a beaker with some ice.
2. Put in the thermometer carefully immediately into the ice and record the steady rise in temperature.

3. Arrange the apparatus as in figure 2.4 (The teacher will demonstrate how to arrange the apparatus then one member of your group will guide the other members) and heat the ice gently while carefully stirring with the thermometer. Record your observations.



*Fig 2.4 Heating ice*

***Fairness is my other name!***

*Ensure you record accurate readings obtained from your thermometer. Never use other people's readings or use guess work. Be honest!*

4. Record the temperature of the ice every 30 seconds in the table provided until all the ice melts. Continue heating while recording the temperature until boiling occurs.
5. (a) After boiling, continue heating for about two minutes. Record your results in a table like the one shown below.

Time (Sec)	0	30	60	90	120	150	180	210	240	270	300
Temp (°C)											

- (b) Plot a graph of temperature (vertical axis) against time (horizontal axis).
6. Using the same procedure, carry out an investigation of how the changes in heat will affect how the ice melt's.
7. (a) Record the results in a table.  
(b) Plot a graph of temperature against time.

**Work to do**

- (a) What does ice form when it melts?  
(b) Did temperature change during melting?  
(c) Give a reason for your answer in 2(b) above.
- (a) What does water change to when it boils?  
(b) Did temperature change during boiling?  
(c) Give a reason for your answer in 3(b) above.
- Why is the thermometer used in this experiment?

4. From your recordings, share with the class if you got the same readings or not. Explain the reason for your answer.
5. Did the change in heat affect the rate at which the ice melted? Explain your answer.

### The Facts

When ice is heated, its temperature rises steadily until it reaches  $0^{\circ}\text{C}$ . At this point, ice changes into liquid water.

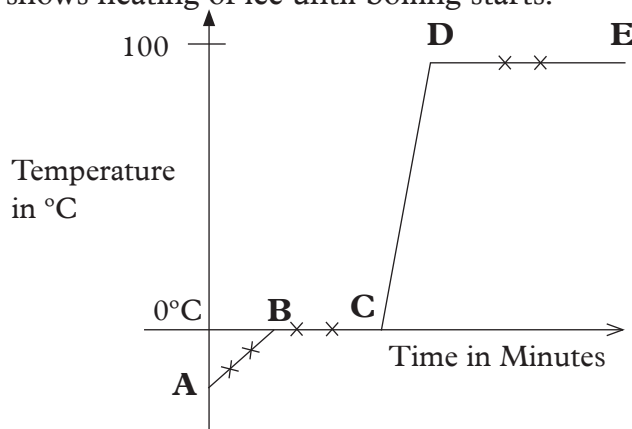
The temperature remains constant at this point as ice changes to liquid water despite the fact that heating continues. This process is called melting.

On further heating, the temperature rises steadily up to  $100^{\circ}\text{C}$  when the liquid water starts to change to vapour.

Again the temperature remains constant as the water changes to vapour. The process of a liquid changing into vapour is called evaporation.

Thermometer in this experiment enables us to know the temperature at which change of state occurs.

The graph below shows heating of ice until boiling starts.

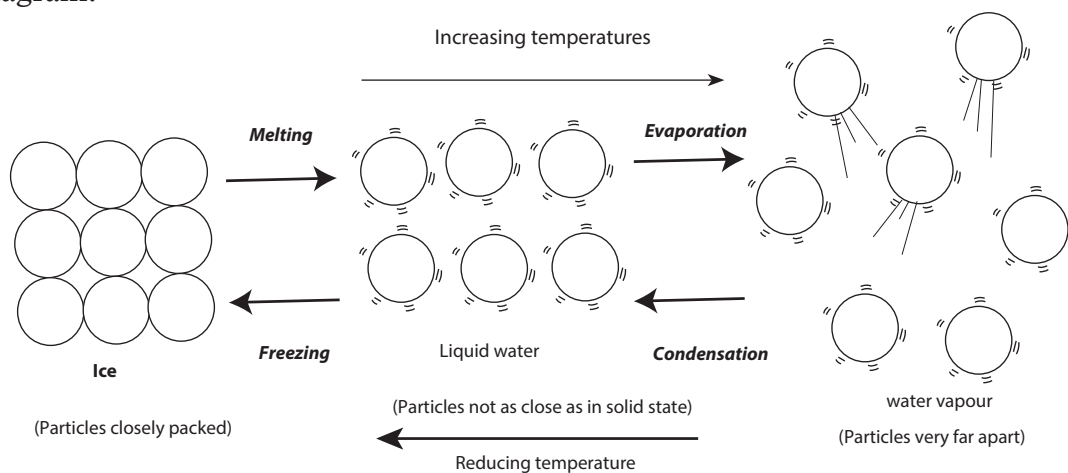


*Fig 2.5 Heating curve of ice*

We can explain what happens in each region as follows:

- **Region AB:** The temperature rises steadily as the ice absorbs heat energy. The temperature rise stops at  $0^{\circ}\text{C}$ .
- **Region BC:** The temperature remains constant ( $0^{\circ}\text{C}$ ), until all the ice has melted. This is because the heat energy absorbed in this region is used to break the forces of attraction holding the solid particles together. Water changes its physical state from solid to liquid form at this point.
- **Region CD:** Temperature rises steadily as the liquid water absorbs heat energy. The temperature rise stops when the liquid water starts changing into vapour (evaporation).

- **Region DE:** The temperature remains constant as the liquid water changes into water vapour. Heat energy absorbed is used to break the forces of attraction holding water particles together. Water thus changes into vapour. Changes that occur when ice is heated can be illustrated in the following flow diagram.



*Fig. 2.6 Flow chart showing change ice to liquid then to vapour.*

The changes of state from solid to liquid and liquid to gas can be reversed by cooling. On cooling, the gas **condenses** into liquid and finally the liquid **freezes** into solid as shown in the flow diagram.

### Activity 2.3

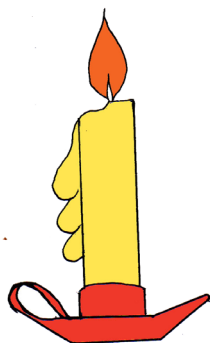
#### *Procedures melting and sublimation*

#### *Apparatus and reagents*

Candles, iodine, naphthalene, boiling tubes, water, spatula, a pair of tongs, electronic weighing balance, a jar and Bunsen burner

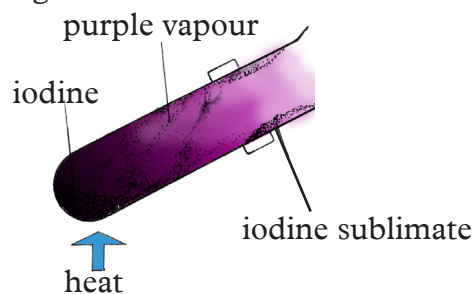
#### *Procedure:*

1. Light a candle. Let the candle burn and record your observations.



*Fig 2.7 Burning candle*

- Place a few iodine flakes in a boiling tube and hold the boiling tube with a pair of tongs.
- Heat the boiling tube gently over a non-luminous flame. Observe and record any observable changes.

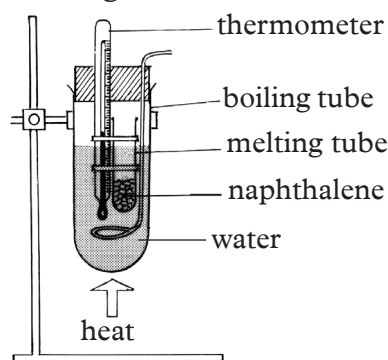


*Fig 2.8 Sublimation of iodine*

**Quality is my choice!**

*Use a weighing balance that has been approved by the South Sudan National Bureau of Standards (SSNBS)*

- Place 5 g of naphthalene in a boiling tube and hold the tube with a pair of tongs or clamp.
- Heat as you observe the changes.



*Fig 2.9 Heating naphthalene*

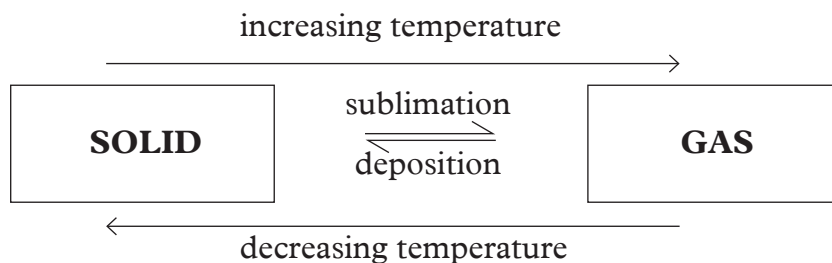
**Work to do**

- What observations are made when the candle is lit?
  - State the changes of state that take place when the candle is lit.
- What is observed when:
  - Iodine flakes are heated?
  - The product obtained is allowed to cool?
- What is observed when:
  - Naphthalene is heated
  - The product is left to cool?



## The Facts

When some solids such as **iodine** are heated, they change from solid directly to gas without passing through the liquid state. This change is called **sublimation**. On cooling, the substances condense from gas to solid. The process is known as **deposition**.



Another example of a substance that sublimates is **ammonium chloride**.

### Activity 2.4

#### Investigating physical changes

#### In groups

#### Apparatus and reagents

Test tubes, Bunsen burner, test tube holder, candle wax, water, wooden splints, zinc (II) oxide, lead (II) oxide, beakers and boiling tube.

#### Procedure

1. Place few pieces of candle wax in a test tube.
2. Hold the test tube with the tube holder and heat.
3. Allow it to cool then record the observations.

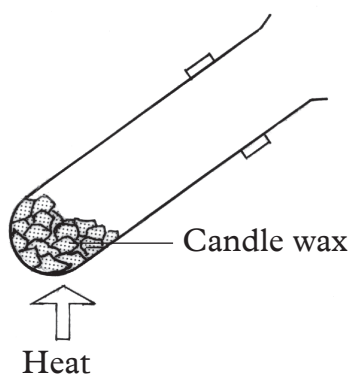


Fig 2.10 Heating candle wax

4. Heat 5 cm<sup>3</sup> of water in a test tube until it boils. Observe the steam formed at the cooler part of the test tube. Record your observations.
5. Take a piece of wooden splint, break it into small pieces. Is there a new substance that is formed?

6. Place a spatulaful of zinc (II) oxide and lead (II) oxide in two separate test tubes.
7. Hold each with a test tube holder and heat.
8. Allow them to cool and observe their colours when cold.
9. Record your observations.

### Work to do

1. State the observations made when:
  - (i) Candle wax is heated then allowed to cool.
  - (ii) Liquid water is boiling.
- (ii) Compare the observations from the activity with the predictions you made. Was there any difference?
2. Is there a new substance that is formed when a piece of wooden splint is broken down?
3. Compare the changes that take place when zinc oxide and lead (II) oxide are heated separately.

### The Facts

As seen from this activity, some of the characteristics of a physical change are:

1. No new substance is formed.
2. The mass of the substance does not change.
3. It is easily reversible.

### *Money matters!*

*Cooking fat should always be kept in a cool and dry place to prevent it from melting out.*

## Chemical changes

### Work to do

1. In groups, discuss what you think would happen if you completely burn a piece of paper and a wooden splint.
2. Is the change reversible. Why do you think is so?
3. Would you say this is a physical change? Explain your answer.

## Activity 2.5

### *Investigating chemical changes*

#### *In groups*

#### **Apparatus and reagents**

Test tubes, Bunsen burner, wooden splint, a piece of paper, magnesium ribbon, iron nails, water, pair of tongs.

#### **Procedure**

1. Light a wooden splint in a Bunsen burner flame.
2. Allow it to burn for some time.
3. Compare the product formed with the initial splint. Are they the same?
4. Burn a piece of paper to form ash.
5. Compare the product with the initial paper. It is possible to get back the paper from the ash?
6. Using the pair of tongs, heat a piece of magnesium ribbon on a Bunsen burner flame. Allow the magnesium to burn.

**Caution!** Burning magnesium produces intense light that can cause temporary loss of sight. Do not look directly at the light source.

7. Collect the product and compare it to the initial magnesium ribbon.
8. Place few iron nails in a test tube containing water.
9. Keep it in an open place for one week. What do you observe?
10. Explain your observation in (9) above.

### Work to do

1. (a) State the observations made when the following substances are burnt.  
(i) Wooden splint    (ii) Piece of paper    (iii) Magnesium ribbon  
(b) How are the products formed in (a) above different from with the initial substances?  
(c) Are there new substances that are formed?  
(d) Why are those changes considered to be chemical changes?
2. Explain what happens to the iron nails.
3. Comparing your results to your predictions, were the predictions correct?

### *Money matters!*

*It is advisable to paint iron sheets to avoid regular expenses of replacing them when they rust.*

## The Facts

When wood is burnt, it changes to ash. We cannot get back wood from the ash. This reaction is thus **irreversible**. Similarly, when magnesium is burnt in air, it forms powder. It is not possible also to get back the magnesium ribbon from the powder. The white powder formed is called **magnesium oxide**. It is as a result of combining magnesium with oxygen in air.

All these processes are well reversible. They are therefore called **permanent changes**. Permanent changes are chemical changes.

Some of the characteristics of chemical changes include:

1. New substances are formed.
2. It is difficult to change the new substance back into the original substance. (irreversible).

### Check your progress 2.2

1. Cooking fat should be stored in a cool dry place. What is the importance of this precaution?
2. State whether the following are physical or chemical changes.
  - (i) Burning a match stick into ash.
  - (ii) Freezing water to make an ice cube.
  - (iii) Explosion of a bomb.
3. (i) Zinc oxide changes to \_\_\_\_\_ colour on heating and \_\_\_\_\_ colour on cooling. It undergoes a \_\_\_\_\_ change.  
(ii) Iodine changes to \_\_\_\_\_ on heating and \_\_\_\_\_ on cooling. It undergoes \_\_\_\_\_ change.
4. Compare the difference between physical and chemical changes.
5. State whether the following statements are **true** or **false**.
  - (a) Burning wood is a chemical change.
  - (b) Drying a shirt in the sun is a chemical change.
  - (c) Dissolving sugar in tea is a physical change.
  - (d) Cooking meat is a chemical change.
6. State whether the changes that occur after the following activities are physical or chemical changes. Give a reason for each case.
  - (i) Place unripe bananas in a paper bag and keep them for 10 days. Observe the changes on the tenth day. Compare the unripe banana with the product you get after 10 days.
  - (ii) Place some glucose in warm water and add 3 g of yeast. Leave the mixture in a warm place (30°C) for three days. Comment on the smell produced by the product.

## 2.4 Kinetic theory of matter

### Activity 2.6

*To investigate the movement of particles.*

1. Get some marbles and a plastic bottle with a cap.
2. Put a few marbles for example 5 in the bottle then close the cap.
3. Agitate the marbles by shaking the bottle. What do you observe?
4. Fill the bottle half way with marbles and shake the bottle once more.
5. Compare how the marbles move with the first instance.
6. Now, fill the bottle completely with marbles, close the cap and try shaking the bottle. Do the marbles move?
7. Explain your observation in (6) above.
8. Compare the three scenarios to the arrangement of particles in solids, liquids and gases.
9. Discuss the results of the experiment in your group and write a summary report.

### The Facts

Matter consists of particles arranged in a certain way. This arrangement varies from one state of matter to another. The arrangement and movement of particles in solids, liquids and gases is explained by the **Kinetic theory of matter**. The word kinetic is derived from the Greek word '**Kineo**' which implies 'motion'.

The kinetic theory therefore explains:

- how particles that make up matter are packed in solids, liquids and gases
- the movement of these particles.
- the attractive forces between the particles and the effect of temperature on them.

According to the Kinetic theory, particles in matter are always in constant motion. For this reason, they possess **kinetic energy**. Kinetic theory of matter can be used to explain the properties of the various states of matter. The theory also explains what happens during change of state.

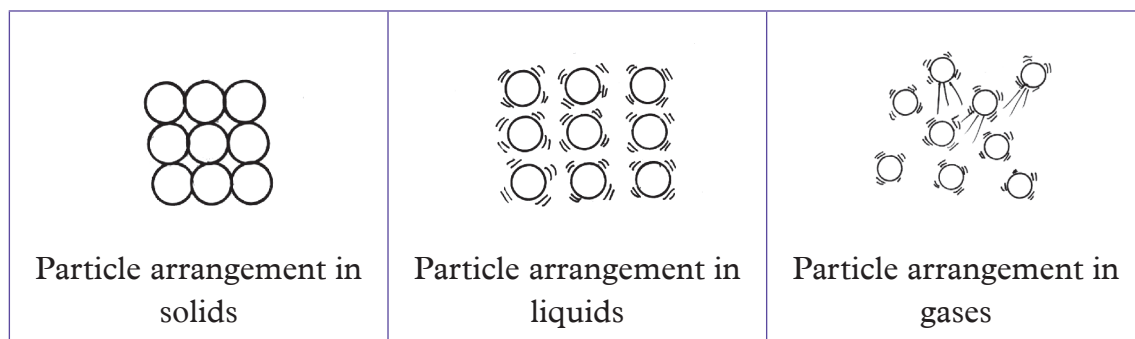
### *Packing of particles in terms of kinetic theory*

Particles of a **solid** are closely packed. They are held in fixed positions by strong **interparticle forces** of attraction. They therefore vibrate but they do not move from one place to another. It is for this reason that solids have a fixed shape.

In a **liquid**, particles are free to move randomly but tend to stick together. This is because they have **moderate forces of attraction** between them. They are hence less closely packed as compared to solid particles.

The particles of a **gas** have weaker forces of attraction between them. This is why

they are very far apart. They are therefore free to move randomly in any direction. For this reason, a gas occupies the entire space of a container and so a gas has no definite shape.



## 2.5 Change of state and kinetic theory

### Work to do

In pairs discuss the following.

1. What can you do to convert solid ice to water?
2. What is required for one to convert water into steam?
3. Give the names of the processes that take place in (1) and (2) above?
4. What is done to reverse the processes you have mentioned in (3) above?
5. Give the names of the reverse processes by which steam is converted to water and water to solid ice?

### The Facts

The various processes that lead to change of state include:

- (a) Melting
- (b) Evaporation
- (c) Condensation
- (d) Freezing

#### (a) Melting

When a solid is heated, the kinetic energy of the particles increases and they vibrate more vigorously within their fixed positions. Further heating weakens the forces of attraction between the particles. The solid thus changes to liquid. This is the melting process. The temperature at which melting occurs is known as the **melting point**.

#### (b) Evaporation

When a liquid is heated the particles gain more kinetic energy and the particles start to move more rapidly. When the liquid gets hot enough the forces of attraction joining the fast moving particles at the surface are broken detaching them from the

other particles. The surface particles thus escape into the air.

The liquid then changes into gaseous state. The temperature at which evaporation takes place is called the **boiling point**.

### (c) Condensation

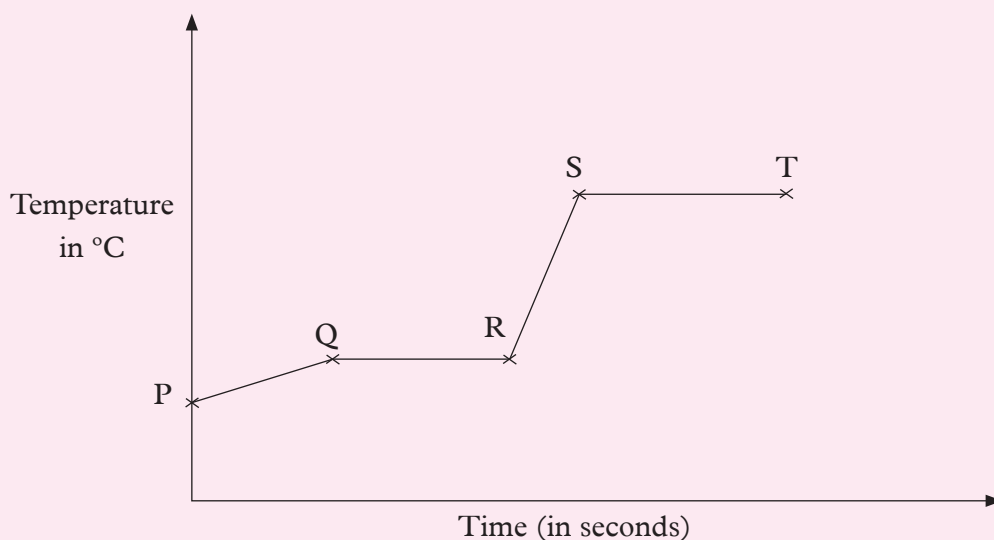
When the gas is cooled, the kinetic energy of its particles decreases. The movement of the particles slows down and they come close together. At this point the attractive forces between the particles become sufficient to hold them together. The gas then becomes a **liquid**.

### (d) Freezing

Further decrease in temperature, makes the liquid particles to slow down their movement further. The particles come closer together and the forces of attraction between them increase. They hence vibrate within fixed positions. The particles are not free to move from one place to another. A **solid** is hence formed.

### Check your progress 2.3

1. What name do we give to the following processes:
  - a) Change of solids to liquids
  - b) Change of liquids to solids.
2. Draw a diagrammatic representation of the arrangement of particles in solids, liquids and gases.
3. The following graph shows the changes that occur when a solid is heated until boiling starts. Study it and answer the question that follow.



Explain what happens in regions:

- (i) P Q      (ii) Q R      (iii) R S      (iv) S T

## Work to do

- (a) Do you have compost pits in your school?  
(b) If you have them, where in the school compound are they located?  
(c) Why do you think they are dug in such locations?
- Why do you think latrines are always built considering the direction of wind and a distance away from the main house?

## The Facts

Movement of particles of a substance from a region of high concentration to a region of low concentration is called **diffusion**.

## Activity 2.7

### a) Investigating diffusion

#### *Apparatus and reagents*

A beaker of water, a container of ink, a can of perfume spray.

#### *Procedure*

- (a) Add a drop of ink into the water. What do you notice?  
(b) Add another drop of ink. Does the same thing happen again?  
(c) What do you conclude?
- Remove the lid of the perfume can and press on top away from everyone.  
What do you notice after a few minutes?

#### *Health check!*

*Let the students who are perfume intolerant stay away from the perfume.*

## The Facts

When a drop of ink is placed onto a beaker of water, the ink particles spread until all the water is uniformly coloured. Also, after a few minutes of opening the perfume can, the smell of the perfume can be felt in the air.

The ink spreads in water and perfume is smelled due to the movement of particles. We can hence say that the particles moved from the region where they were great in number to the region where they are fewer in number by the process of diffusion.



## Activity 2.8

### b) Investigating diffusion in gases

#### Apparatus and reagents

Long glass tube, concentrated ammonia solution, concentrated hydrochloric acid, cotton wool, tongs, clamp stand.

#### Procedure

1. Clamp a long glass tube horizontally as shown in figure 2.11.
2. Soak two pieces of cotton wool, one piece in concentrated ammonia solution and the other in concentrated hydrochloric acid separately (**do not** allow the soaked pieces to come close to one another).

**Caution!** Ammonia and hydrogen chloride gases are poisonous. Always waft gas towards your nose if you have to smell them.

3. Quickly insert the soaked cotton wool pieces simultaneously at the opposite ends of the long glass tube.

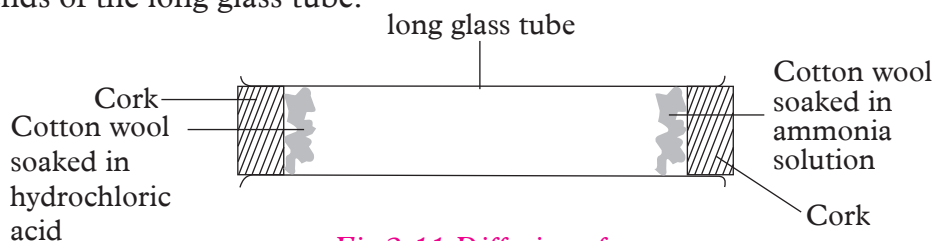


Fig 2.11 Diffusion of gases

4. Carefully observe what happens in the glass tube.
5. Measure the distance from both ends of the glass tube to the position where a patch is seen.

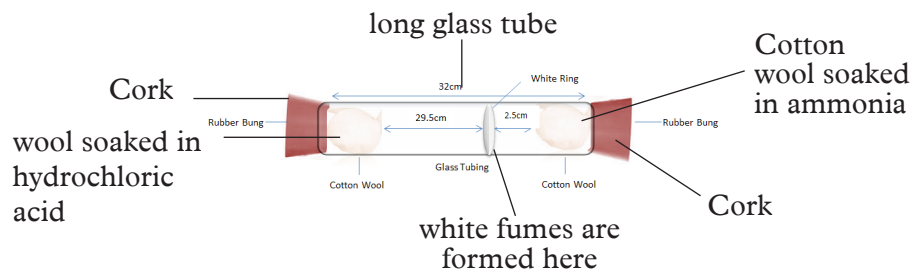
### Work to do

1. What observations are made in the glass tube?
2. At what distance from both ends of the long glass tube are the observations made?
3. Explain the observations made in the tube.

### The Facts

The cotton wool soaked in concentrated ammonia solution gives out ammonia gas whereas the cotton wool soaked in concentrated hydrochloric acid gives out **hydrogen chloride gas**. Ammonia and hydrogen chloride gases diffuse in the

long glass tube. When the two gases meet, they react to form dense white fumes of **ammonium chloride** after about 5 minutes. The ammonium chloride is seen as a white ring.



*Fig 2.12 Formation of ammonium chloride*

The white ring is formed closer to the end with cotton wool soaked in concentrated hydrochloric acid. Ammonia gas has less dense particles. Its particles therefore, moves faster than hydrogen chloride gas particles.

### The Facts

Diffusion is affected by several factors namely; temperature, concentration gradient, surface area and density of the particles. Diffusion occurs faster at higher temperatures than at lower temperatures. A gas with low density diffuses faster than that with high density. Diffusion does not take place in solids.

## Brownian motion

### Work to do

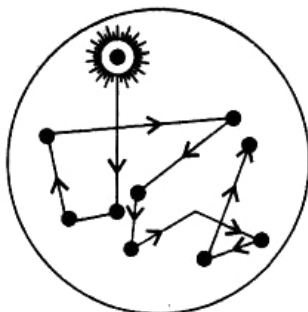
1. Suspend pollen grains in a container with water.
  - Note the movement of the grains in water.
2. What kind of motion did they make?

### The Facts

Brownian motion is the random movement of particles suspended in a fluid. This is as a result of the movement of the particles from their collision with the quick moving particles in the fluid.

This phenomenon is named after **Robert Brown** an English Botanist who discovered it. In 1827, while examining grains of pollen of a plant suspended in

water under a microscope, Brown observed minute particles ejected from the pollen grains executing a continuous zigzag motion. This kind of movement is what is known as **Brownian motion**.



*Fig 2.13 Brownian motion*

#### Check your progress 2.4

1. You are provided with the following: *potassium permanganate, glass tube, beaker, spatula and water*. Explain how you would demonstrate diffusion.
2. Just like animals, plants also need certain ions to be able to grow. Explain how they obtain these ions from the soil.
3. State whether this statement is true or false:  
Diffusion is slower in air than it is in liquids.
4. Explain your answer in (3) above.
5. A secondary one student placed  $200\text{ cm}^3$  of water in a  $500\text{ cm}^3$  glass beaker. She then crushed a piece of chalk into fine powder and placed them in the water. She stirred and heated the water to boiling as she observed. What was she trying to find out?
6. When cotton wool was soaked in ammonia solution and hydrochloric acid and the two were inserted in opposite ends of a glass tube, the white ring was formed closer to the end with cotton wool soaked in concentrated hydrochloric acid. Explain why the white ring formed closer to the cotton wool soaked in concentrated hydrochloric acid.

## 2.6 Definition of element, atom and molecule

In order to appreciate what atoms, elements and compounds are, carry out the following activity.

### Activity 2.9

1. Take a piece of paper. Note its size.
2. Tear the piece of paper into half. Note the size of the resultant papers. Which one is smaller? These pieces or the original paper?
3. Continue tearing the pieces of paper into halves until you can no longer tear them. Why do you think you are not able to tear the pieces of paper further?
4. Now, burn the pieces of paper that you teared. Observe the product formed. What is its colour? Why is it different from the original colour of the paper?
5. As the secretary of a class consisting of thirty-two students, you have a single orange; all the class members need a share of the fruit:
  - (a) How will you share it with everyone equally?
  - (b) Is there a point at which the orange will be too small that you can no longer divide it?
  - (c) How small were the pieces?
  - (d) Could they be seen or touched?

### The Facts

All objects from our everyday life that we touch or see are composed of small particles called **atoms**.

An **atom** is the smallest particle into which an element can be divided without losing the chemical properties of the element.

Atoms are usually very small such that they cannot even be seen with the aid of a microscope.

An **element** is a type of matter composed of atoms that all have the same atomic number. Atoms of the same element or different elements can combine. When they do so, they form molecules.

A **molecule** is a particle made up of two or more atoms that are chemically bonded together, for example, water.

## 2.7 Symbols of chemical elements

### Work to do

1. (a) Why are people given names at birth?  
(b) And what do people consider when naming?
2. Why do people have different names?
3. When you go to shop, how do you know that a certain product is actually manufactured by a particular company?
4. How can I know that a product I am about to buy is of quality and safe for consumption?

### The Facts

In Chemistry, elements are given certain names considering either where they were discovered or who discovered them. It is from these names that symbols are obtained. The symbols of elements are different and specific to each element. This creates orderliness when organising information about different elements.

The system of writing symbols uses letters taken from the name of the element. This could be the English or Latin name of the element.

The symbol of an element may consist of one or two letters. The first letter of a chemical symbol must always be a capital letter. The letters should not be joined. These symbols are an **international code**. This means that all over the world, they are written in the same way no matter how people spell the name of the element in their language. The symbol of an element thus remains the same in all languages.

*Table 2.2 First 20 elements with their symbols*

	Element	Symbol
1	Hydrogen	H
2	Helium	He
3	Lithium	Li
4	Beryllium	Be
5	Boron	B
6	Carbon	C
7	Nitrogen	N
8	Oxygen	O
9	Fluorine	F
10	Neon	Ne
11	Sodium	Na
12	Magnesium	Mg
13	Aluminium	Al

	Element	Symbol
14	Silicon	Si
15	Phosphorus	P
16	Sulphur	S
17	Chlorine	Cl
18	Argon	Ar
19	Potassium	K
20	Calcium	Ca

The following elements, symbols use two letters obtained from their **English name** as their symbols.

*Table 2.3: Elements with symbols derived from their English names*

Element	Symbol
Calcium	Ca
Cobalt	Co
Chlorine	Cl
Magnesium	Mg
Manganese	Mn

Below are element symbols which use one or two letters from their Latin names.

*Table 2.4: Elements with symbols derived from their latin names*

Element	Latin	Chemical symbol
Potassium	Kalium	K
Sodium	Natrium	Na
Iron	Ferrum	Fe
Lead	Plumbum	Pb
Silver	Argentum	Ag
Copper	Cuprum	Cu
Mercury	Hydragyrum	Hg
Gold	Aurum	Au

### Check your progress 2.5

1. What is an atom?
2. Differentiate between an element and molecule.
3. Practice with a friend the first 20 elements of the periodic table

## 2.8 Main components of an atom

The components of the atom are known as sub-atomic particles. **Protons** and **neutrons** are found in a central location within an atom. This location is called the **nucleus**. **Electrons** are found outside the nucleus but within the atom.

The nucleus of an atom is positively charged due to the presence of protons which are positively charged. Neutrons carry no charge.

Electrons are negatively charged and keep on moving round the nucleus experiencing a force of attraction from the nucleus.

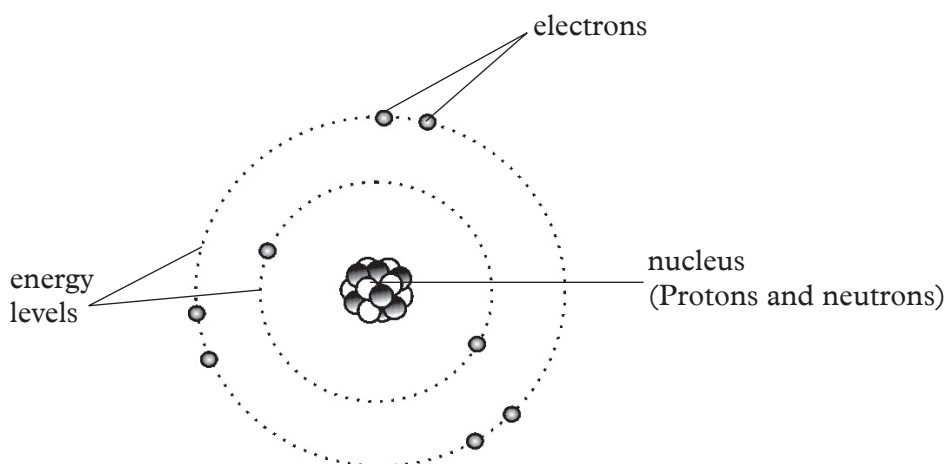
Electrons occupy special positions known as **levels**.

A sub-atomic particle consists of characteristic charge, mass and its symbol.

*Table 2.6 Properties of sub-atomic particles*

Particle and its symbol	Relative Mass	Relative Charge
Protons (p)	1	+1
Electrons (e)	1/1840	-1
Neutrons (n)	1	0

The number of protons is equal to the number of electrons. For this reason, the atom is considered **electrically neutral**.



*Fig 2.14 Atomic structure showing nucleus and electrons*

## 2.9 Atomic characteristics

### **The Facts**

The number of protons in the nucleus of the atom is always referred to as the **atomic number**.

The symbol for the atomic number is (**Z**).

When the total number of protons and neutrons are added we get the **mass**

### **number.**

The symbol for mass number is (**A**).

We can use the numbers on any atom to work out the number of protons, neutrons and electrons.

Using the relationship:

$$A = Z + N$$

Where **N** is the number of neutrons in an atom, we can work out the number of neutrons as follows.

### **NOTE:**

**A** – represents the mass number

**Z** – represents the atomic number

**N** – represents the number of neutrons

### **Example**

The mass number of sodium is 23 and the number of protons in its atom is 11. Calculate the number of neutrons in an atom of sodium.

If  $A = Z + N$  then  $N = A - Z$

Therefore,  $N = 23 - 11 = 12$ , the number of neutrons is hence 12.

The difference in number of neutrons leads to difference in mass number.

One element may have more than one type of atom based on differences in number of neutrons. Such atoms are known as **isotopes**.

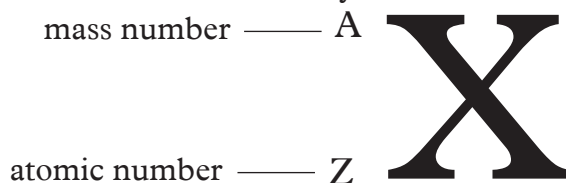
**Isotopes** have the same chemical behaviour but slightly different physical properties.

### **Example:**

There are two isotopes of chlorine.

- Chlorine – 37
- Chlorine – 35

With the knowledge of mass number, atomic number and the chemical symbol, an atom of an element can be represented using the symbol of the element. On the symbol, mass number is written as a superscript while the atomic number is written as a subscript. Both are written before the symbol.



Can you think of how the symbol of sodium atom would be if represented this way?



## Check your progress 2.6

1. A carbon atom has 6 protons, 6 electrons and 8 neutrons, calculate the mass number.
2. How many neutrons are present in the nucleus of calcium atom?

## 2.10 Electronic configuration

### Work to do

Collect the following materials and ask your teacher to provide you with material that cannot be obtained within your environment.

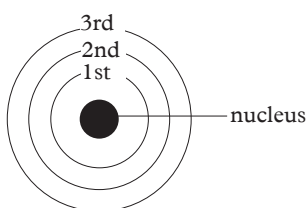
#### Materials

Three types of seeds e.g. beans, maize, peas, green grams, rice grains, two manila sheets, glue, scissors and mathematical set.

Make two models of energy shell diagram showing the electron arrangement of an oxygen atom. Use different seeds for protons, neutrons and electrons.

### The Facts

Energy level is a possible location around an atom where electrons are found. They are represented as  $n = 1, 2, 3$  etc as shown in the following figure. There are 7 possible energy levels in atoms.

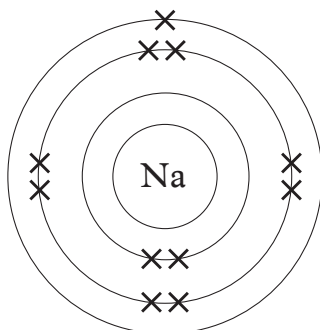


*Fig 2.15. Energy Levels*

The first energy level (**labelled 1**) can hold up to only two electrons.

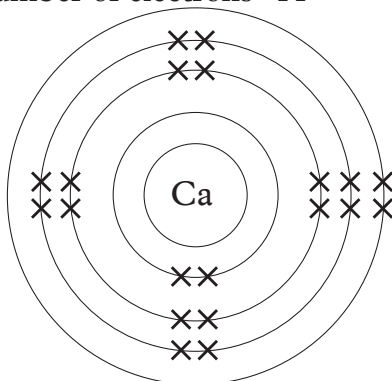
The second energy level (**labelled 2**) can hold a maximum of eight electrons. This energy level is filled after the first energy level and before the third level.

The third energy level (**labelled 3**) can hold a maximum of 18 electrons, however when 8 electrons are in the third level there is a degree of stability; and other electrons are added to the fourth energy level. Electrons must first fill the first energy level before they start occupying the second energy level.



*Fig 2.16 Shell model for sodium (Na)*

Number of protons=11, number of electrons=11



*Fig 2.17 Shell model for calcium (Ca)*

Number of protons = 20, number of electrons = 20

*Table 2.5: Atomic number, mass numbers, sub-atomic particles and electronic configuration of the first 20 elements in the Periodic Table*

Element and symbols	Atomic number (z)	Mass number (A)	Sub-atomic particles			Electronic structure	Lewi's electronic arrangement
			p	n	e <sup>-</sup>		
Hydrogen (H)	1	1	1	0	1	1	
Helium (He)	2	4	2	2	2	2	
Lithium (Li)	3	7	3	4	3	2.1	
Beryllium (Be)	4	9	4	5	4	2.2	

Element and symbols	Atomic number (z)	Mass number (A)	Sub-atomic particles			Electronic structure	Lewis electronic arrangement
			p	n	e <sup>-</sup>		
Boron (B)	5	11	5	6	5	2.3	
Carbon (C)	6	12	6	6	6	2.4	
Nitrogen (N)	7	14	7	7	7	2.5	
Oxygen (O)	8	16	8	8	8	2.6	
Fluorine (F)	9	19	9	10	9	2.7	
Neon (Ne)	10	20	10	10	10	2.8	
Sodium (Na)	11	23	11	12	11	2.8.1	
Magnesium (Mg)	12	24	12	12	12	2.8.2	
Aluminium (Al)	13	27	13	14	13	2.8.3	

Element and symbols	Atomic number (z)	Mass number (A)	Sub-atomic particles			Electronic structure	Lewis electronic arrangement
			p	n	e <sup>-</sup>		
Silicon (Si)	14	28	14	14	14	2.8.4	
Phosphorus (P)	15	31	15	16	15	2.8.5	
Sulphur (S)	16	32	16	16	16	2.8.6	
Chlorine (Cl)	17	35	17	18	17	2.8.7	
Argon (Ar)	18	40	18	22	18	2.8.8	
Potassium (K)	19	39	18	20	19	2.8.8.1	
Calcium (Ca)	20	40	20	20	20	2.8.8.2	

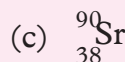
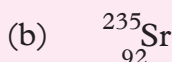
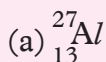
## 2.11 Elements and compounds

### The Facts

An **element** is a type of matter composed of atoms that all have the same atomic number. When two or more elements combine a compound is formed. A **compound** is therefore defined as a pure substance made up of two or more elements chemically combined. A **molecule** is the smallest particle of a substance that retains the chemical and physical properties of the substance and is composed of two or more atoms.

### Check your progress 2.7

1. Given the following substances; common salt, water, nails, sand and kerosene. Classify them into elements and compounds.
2. A student is sent by the teacher to the laboratory to collect samples of cobalt and copper from the laboratory storage room. On reaching the shelves, she finds that all the metals are labelled using their symbols. How can she recognise the two metals before collection?
3. While at home, you come across lead acid battery containing this symbol Pb.
  - (a) What is the meaning of this symbol?
  - (b) Why should this be a matter of concern to you?
  - (c) Suggest the most appropriate ways of disposing of used lead acid batteries.
4. With the help of a diagram, show the electron arrangement of the following atoms.
  - (a) Fluorine – 9 electrons
  - (b) Aluminium atom – 13 electrons
5. State the number of protons, neutrons and electrons in the following atoms.



## 2.12 Formation of ions

### The Facts

Atoms are electrically neutral; the number of protons i.e positive charges in the nucleus is equal to the number of electrons i.e negative charges in the energy levels. However, most atoms with the exception of group VIII elements do not possess stable electron configuration i.e. **noble gas electronic configuration**. An atom is said to be stable when its outermost energy level has the maximum number of electrons it can hold. Otherwise, it is said to be unstable. An unstable atom can gain stability by either gaining or losing one or more electrons. When an atom gains

electron(s) to gain stability it becomes negatively charged. On the other hand, when an atom loses electron(s) to be stable it becomes positively charged. A positively charged ion is called a **cation** while a negatively charged ion is called an **anion**.

**Noble gas** electronic configuration implies that the outermost energy level has the maximum number of electrons that it can accommodate.

**What determines whether an atom will gain or lose an electron to gain stability?**

This is determined by the number of electron in the outermost energy level of the atom. Consider for example the atom of sodium and that of chlorine.

The electron configuration of sodium is 2.8.1. Sodium can only be stable if the outermost energy level has 8 electrons. Less energy will be required to lose one electron than to gain 7 electrons. The stable ion of sodium will thus have the electron arrangement of 2.8. On the other hand, chlorine has an electron arrangement of 2.8.7. Chlorine will require less energy to gain one electron and be stable than lose 7 electrons. The stable ion of chlorine will thus have an electron arrangement of 2.8.8.

### Examples

(a) Formation of a sodium cation.

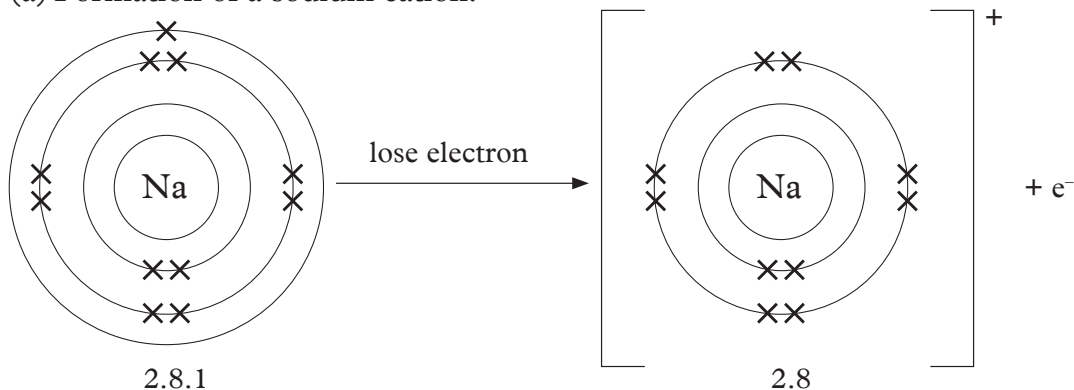


Fig 2.18 Formation of Sodium Ion ( $\text{Na}^+$ )

(b) Formation of a chloride anion

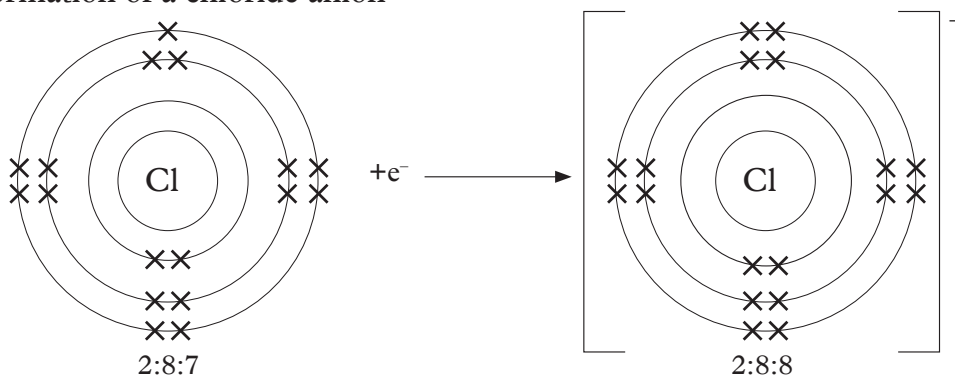


Fig 2.19 Formation of Chloride Ion ( $\text{Cl}^-$ )

## Check your progress 2.8

1. What do the words duplet and octet imply?
2. An element is represented as  ${}^{20}_{10}\text{X}$ .
  - (a) Write the electronic configuration of the element.
  - (b) What is its mass number and atomic number?
  - (c) Calculate the number of neutrons in this element.
  - (d) Define atomic number and mass number.
3. How is aluminium ion formed?
4. You come across an element;  ${}^{18}_8\text{X}$  and  ${}^{16}_8\text{X}$ . What name do you give such an element? Explain your answer.
5. The symbol of an element is represented by  ${}^{27}_{13}\text{X}$ .
  - (a) Calculate the number of neutrons in the atom of X.
  - (b) State the number of electrons in the atom of X.
  - (c) Write the electronic configuration of X.
6. Study and complete the table below.
 

Sub atomic particle	Symbol	Charge	Location in the atom
		-1	
Neutron			
			Nucleus
7. Why do you think we always have vehicles with different registration numbers?

## 2.13 Radicals

A radical is a group of chemically combined atoms that behave as if they are a single ion in reactions. Radicals have charges.

*Table 2.6: Some radicals and their symbols*

Radical	Symbol
Sulphate	$\text{SO}_4^{2-}$
Carbonate	$\text{CO}_3^{2-}$
Sulphite	$\text{SO}_3^{2-}$
Hydroxyl	$\text{OH}^-$
Hydrogen carbonate	$\text{HCO}_3^-$
Phosphate	$\text{PO}_4^{3-}$
Nitrate	$\text{NO}_3^-$
Hydrogen sulphate	$\text{HSO}_4^-$

## 2.14 Valence of elements and radicals

The valence of an element is its combining power when it forms chemical compounds and molecules.

In metals, the valency is the number of electrons in the outermost energy level. In non-metals, it is the difference between group 8 and group number of the elements. For radicals and ions, valency is the value of the charge on the ion.

## 2.15 Chemical formulae and nomenclature

Every subject has its own special language. For example, in Chemistry we have substances with names like sodium chloride. However, we have a short notation of writing names called formula. The formula for sodium chloride is NaCl, water, which we are all familiar with is H<sub>2</sub>O. Why do we write the 2 in the formula for water whereas not in sodium chloride? These are some of the questions we shall be answering in this section.

A **chemical formula** is written using chemical symbols and valencies.

### Activity 2.10

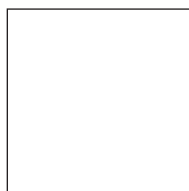
*To demonstrate how valency of elements contribute to the chemical formula of compounds.*

#### **Materials**

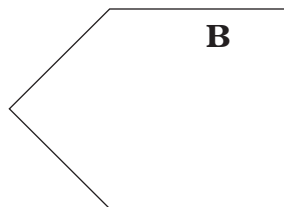
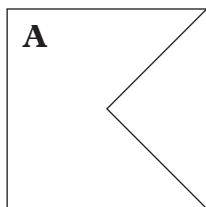
Pair of scissors, manila paper

#### **Procedure**

1. Using the pair of scissors make pieces of manila paper that are 4 cm square as shown.

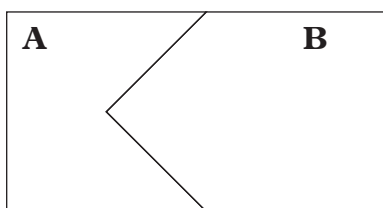


2. Cut two pieces of manilla into two different shapes as shown below.





3. Try joining A and B to fit into each other as shown.



As you can see, the two fit together to form one shape. This is because **A** has one groove while **B** has one projection. We can therefore liken the projection and groove to valencies. This therefore can explain how elements with a valency of one combine to form a compound. An example is sodium and chlorine combining to form sodium chloride (NaCl).

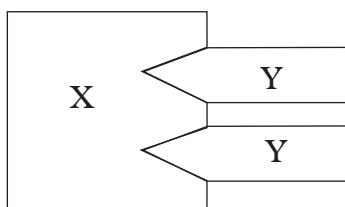
4. Now make two grooves in another piece of manilla as shown. Try fitting it to another piece that has only one projection.



How many pieces of **Y** are needed so that the grooves in **X** are completely filled?

We need two of piece **Y**.

Assuming **X** is magnesium and **Y** is chlorine. Then we shall require two atoms of chlorine to combine with one atom of magnesium. Hence the formula of magnesium chloride is  $\text{MgCl}_2$ .



5. Use the same procedure to show that the formula of the following is correct.
- Aluminium chloride ( $\text{AlCl}_3$ )
  - Aluminium oxide ( $\text{Al}_2\text{O}_3$ )
  - calcium nitrate ( $\text{Ca}(\text{NO}_3)_2$ )

**Example:**

a) Sodium chloride;

- The chemical symbols involved are **Na** and **Cl**; with valencies **1** and **1** respectively.
- Write the valencies as superscripts after each symbol **Na<sup>1</sup>Cl<sup>1</sup>**.

- Interchange the valencies and write them as subscripts after each symbol **Na<sub>1</sub>Cl<sub>1</sub>**.

In the formulae; number 1 is not written.

**Note:** The three rules apply each time you write a formula.

Therefore the chemical formula of sodium chloride is **NaCl**.

- b) Magnesium chloride;

The chemical symbols involved are Mg and Cl

Applying rule no.1 **Mg** and **Cl**; with valencies **2** and **1** respectively

Applying rule no.2 **Mg<sup>2</sup>Cl<sup>1</sup>**

Applying rule no.3 **Mg<sub>1</sub>Cl<sub>2</sub>**

Chemical formula for magnesium chloride is **MgCl<sub>2</sub>**

- c) Aluminum oxide; chemical symbols involved are **Al** and **O** with valencies **3** and **2** respectively.

2. **Al<sup>3</sup>O<sup>2</sup>**

3. **Al<sub>2</sub>O<sub>3</sub>**

Chemical formula for aluminium oxide is **Al<sub>2</sub>O<sub>3</sub>**

- d) Calcium nitrate; chemical symbols involved are **Ca** and **NO<sub>3</sub>** with valencies **2** and **1** respectively.

2. **Ca<sup>2</sup>NO<sub>3</sub>**

3. **Ca<sub>1</sub>(NO<sub>3</sub>)<sub>2</sub>**

Chemical formula for calcium nitrate is **Ca(NO<sub>3</sub>)<sub>2</sub>**

**Note:** When writing a formula composed of radicals, introduce brackets when the radicals are more than one in a molecule.

## Combining power of non-metals

Sometimes non-metal atoms combine with other elements to form molecules.

The molecules may be of similar atoms, for example O<sub>2</sub> or of different atoms for example H<sub>2</sub>O.

**Table 2.7: Various non-metals and a number of molecules they form**

Element	Symbol	Combining Power	Example of Molecules
Hydrogen	H	1	H <sub>2</sub> , H <sub>2</sub> O, CH <sub>4</sub>
Carbon	C	4	CO <sub>2</sub> , CO
Oxygen	O	2	O <sub>2</sub> , CO, H <sub>2</sub> O
Sulphur	S	2	H <sub>2</sub> S, SO <sub>2</sub>
Chlorine	Cl	1	HCl, NaCl
Bromine	Br	1	KBr, Br <sub>2</sub> , HBr
Iodine	I	1	KI, NaI
Nitrogen	N	3	N <sub>2</sub> O, NO

## Writing simple balanced chemical equations

Chemical equations are short, clear and accurate descriptions of chemical reactions. A reaction process can be explained using an equation. For example, when oxygen reacts with magnesium ribbon, a white solid of magnesium oxide is formed. We have been using a word equation to describe such a reaction. Thus:



The (+) sign here is not used to mean addition, but in chemistry it is used to mean 'reacts with'. The  $\rightarrow$  sign is used to indicate formation of a product. Using equal sign instead of an arrow, is wrong.

Names of starting substances like magnesium and oxygen in the above example are written on the left side of the arrow; these substances are called *reactants*. The new substances produced by the chemical reaction are called *products* and are written on the right side of the arrow.



Chemical equations have various notations that indicate the physical states of the reactants and products. These notations are very important. Infact, whenever one writes an equation and misses to write them, the equation is not complete. These notations are as follows:

**Table 2.8 State symbols**

Physical state	Representation of state	Description
Solid	(s)	a solid can be a precipitate, suspension, etc
Liquid	(l)	a pure liquid like water, paraffin, etc
Aqueous	(aq)	a solute or liquid dissolved in water
Gas	(g)	a gas or vapour

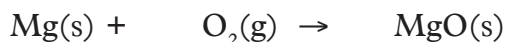
## Balancing chemical equations

In order for an equation to describe a reaction accurately, the equation must be balanced. Chemical reactions should always follow the law of conservation of mass so that the total mass of reactants must be equal to the total mass of products.



**Fig. 2.20: Conservation of mass in a balanced chemical reaction**

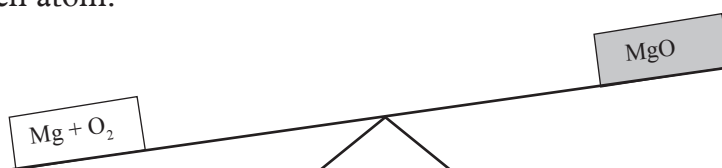
Let us consider our previous example of magnesium ribbon reacting with oxygen. We can write an initial equation containing the formulae of reactants and products.



This equation is not balanced. Count the number of atoms of the reactants and the products.

REACTANTS	PRODUCT
1 Magnesium atom	1 Magnesium atom
2 Oxygen atoms	1 Oxygen atom

The left side (reactants) has two oxygen atoms but the right side (product) has only one oxygen atom.

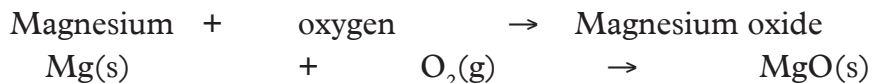


*Fig. 2.21: Unbalanced equation, more oxygen atoms on the left*

An equation can be balanced using a number of rules. Let us follow these rules to balance the above equation.

#### Rule number 1

Write the equation using correct formulae for the reactants and products



## Rule number 2

Count the number of atoms of each element in the reactants and in the products. Check whether they are equal as in Table 2.9.

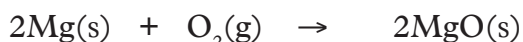
*Table 2.9 Balancing number of atoms for each element in the reactants and product*

Atoms	Reactants	Product
Mg	1	1
O	2	1

We notice that the oxygen atoms are not equal. We have 2 atoms on the left and only one on the right.

### Rule number 3

To make oxygen atoms equal, balance the equation by writing numbers *in front of the formula*. Remember that 1 is assumed to be there already. Therefore start by inserting 2. If this does not balance, go to 3, 4 until the equation is balanced. Usually we do not go to very big numbers.



The number 2 now balances the equation. When you have  $2\text{O}_2$  it means two oxygen molecules. The number in front of a formula means, everything following is multiplied by that number.

**For example:**  $2\text{Mg}$  means  $2 \times \text{Mg}$  that is why we have 2 Mg atoms on the left and 2 Mg on the right.

This equation  $2\text{Mg} + \text{O}_2 \rightarrow 2\text{MgO}$  means 2 atoms of Mg react with 1 molecule of oxygen (containing 2 atoms) to form 2 molecules of magnesium oxide.

### Step number 4

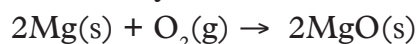
Count again the number of atoms of each element on the reactants and product sides. Note that all atoms are balanced as illustrated in Table 1.22.

*Table 2.10: Balancing of reactants and products*

Atoms	Reactants	Product
Mg	2	2
O	2	2

### Step number 5

Insert the correct state symbols for each substance.



Let us practice the above steps by writing equations for the following reactions.

## Unit test 2.1

1. Study and complete the table below which shows how compounds are formed from metal ions and non-metal ions.

Cation / Anion	OH <sup>-</sup>	SO <sub>4</sub> <sup>2-</sup>	NO <sub>3</sub> <sup>-</sup>	CO <sub>3</sub> <sup>2-</sup>
Ca <sup>2+</sup>				
Na <sup>+</sup>		Na <sub>2</sub> SO <sub>4</sub>		
NH <sub>4</sub> <sup>+</sup>				(NH <sub>4</sub> ) <sub>2</sub> CO <sub>3</sub>
Cu <sup>2+</sup>			Cu(NO <sub>3</sub> ) <sub>2</sub>	
K <sup>+</sup>	KOH			

2. (a) Name the four elements contained in Sodium hydrogen carbonate.  
 (b) Given the positive ion K<sup>+</sup> and negative ion HSO<sub>4</sub><sup>-</sup> write the formula of the compound that would be formed if the two ions combined.
3. Atoms always react because they want to \_\_\_\_\_.  
 (a) Be with other atoms.  
 (b) Form molecules.  
 (c) Attain stable electronic configuration.  
 (d) Gain electrons.
4. Valency is the \_\_\_\_\_.  
 (a) Number of electrons an atom needs to gain to be stable.  
 (b) Combining power of an element.  
 (c) Number of electrons in the outermost energy level.  
 (d) Total number of electrons in an atom.
5. Using crosses to represent electrons, show how the following atoms form ions.  
 (a) Calcium  
 (b) Oxygen
6. An atom  ${}_{19}^{39}\text{X}$   
 (a) How many protons does it have in its nucleus?  
 (b) Calculate the number of neutrons in its nucleus (show your working).  
 (c) Calculate the mass number.  
 (d) Using crosses to represent electrons, draw a diagram to show the arrangement of electrons in X.
7. What is the difference between:  
 (a) Atomic number and mass number  
 (b) Molecules and radicals

8. Explain the kinetic theory to the three states of matter.
9. When ice is heated, it changes its state to liquid then vapour on continued heating whereas a burning splint changes to ash when completely burnt. State the types of changes that took place and explain your answer.
10. Students at Loka Secondary School noticed that their classroom roof top which is made of Iron sheet had undergone rust. Do you think they could do anything to change that? Why?
11. Write a balanced chemical equation of the reaction between:
  - (a) Zinc granules and dilute hydrochloric acid to produce zinc chloride and hydrogen gas.
  - (b) Copper (II) oxide with hydrogen to produce copper and water.
  - (c) Copper carbonate with hydrochloric acid to produce copper (I) chloride, carbon and water.

# UNIT 3

## Acids, bases and salts

Learning outcomes		
Knowledge and understanding	Skills	Attitudes
<ul style="list-style-type: none"> <li>Understand the properties and uses of acids, bases, indicators and salts</li> </ul>	<ul style="list-style-type: none"> <li>Perform practical experiments to investigate the properties of acids, bases and salts</li> <li>Investigate and compare properties of strong and weak acids</li> <li>Use information to identify patterns, report trends and draw inferences</li> <li>Present reasoned explanations for phenomena, patterns and relationships</li> </ul>	<ul style="list-style-type: none"> <li>Adapt behaviour to suit different situations and be aware of the need to work safely</li> </ul>

### Work to do

Look at the pictures below. Do the things in the pictures look familiar? Name them.



A



B



C

Fig 3.1

What are the things made of? Name other substances found at home made of acids and bases. Come up with a list of uses of acids and bases based on your findings above. Based on your answers to above questions, predict what this topic is about.



### 3.1 Definition of acid, base, indicator and salt

#### Activity 3.1

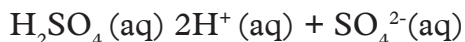
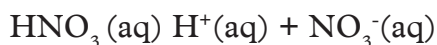
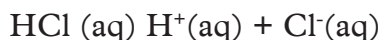
*In pairs, discuss the following questions*

1. Some people take wood ash when they have heartburn. How does it help?
2. Why Should we brush our teeth at least twice a day using a toothbrush and toothpaste?
3. Your teacher will provide you with portions of orange and lemon fruits. Taste them and describe their tastes.
4. Find out what acids and bases are and group the above materials accordingly.

#### The Facts

The taste of fruits such as oranges and lemons is associated with acids. The tastes are either bitter or sour. This is because they contain acids. **An acid** is a substance which when dissolved in water dissociates to give hydrogen ion(s) ( $H^+$ ) as the only positively charged ions.

Examples of acids and the ions they produce on dissociation include:



#### Be safe

*Acids are corrosive, avoid skin contact with acids*

The hydrogen ion ( $H^+$ ) gives acids their characteristic properties.

Acids can either be commercial or natural organic.

Commercial acids are bought from shops or chemical outlets.

Examples of commercial organic acid are given in the following tables.

*Table 3.1 Sources of natural acids*

Name	Where found or used
1. Citric acid	Citrus fruits, eg. oranges, lemons
2. Tartaric acid	Grapes, health salts, baking powder.
3. Lactic acid	Sour milk
4. Ethanoic acid	Vinegar
5. Methanoic acid	In ant, bee and nettle stings
6. Carbonic acid	Coke, lemonade, other fizzy drinks
7. Butanoic acid	Cheese
8. Tannic acid	Tea

**Table 3.2 Common mineral acids**

Name	Where found or used
1. Hydrochloric acid	Found as dilute acid in the stomach. Used to clean metal surfaces
2. Sulphuric acid	car batteries, used to make fertilisers, detergents.
3. Nitric acid	Making fertilisers and explosives

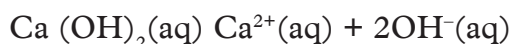
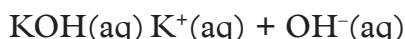
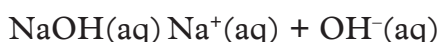
**Note:** Hydrochloric acid is also found naturally in our stomachs.

Gases like carbon dioxide, hydrogen chloride and chlorine also show acidic properties when dissolved in water.

Toothpastes contain bases and things like ash also contain natural bases.

**A base** is a substance which when dissolved in water dissociates to give hydroxide ions ( $\text{OH}^-$ ) as the only negatively charged ions.

Examples of bases include sodium hydroxide, potassium hydroxide and calcium hydroxide. On dissociation these bases give the following ions:



The hydroxide ion ( $\text{OH}^-$ ) gives bases their characteristic properties.

**NOTE:** A base that dissolves in water is called an **alkali**.

Examples of common alkalis and bases are given in Table 3.3 below.

**Table 3.3 Examples of alkalis and bases**

	Where found or used
<b>Bases</b>	
1. Magnesium oxide	Antacid indigestion tablets
2. Calcium oxide	Making cement, neutralising soil acidity
<b>Alkalis</b>	
1. Sodium hydroxide	Making soap and paper
2. Ammonia solution	Making fertilisers, in cleaning fluids at home

## Activity 3.2

### *In groups*

1. Discuss on what you think is used to measure the PH of substances your teacher will provide you with three different substances:  
A mixture of water and baking soda, lemon juice and vinegar, which ones do you think are acids/bases?
2. Predict what will happen to the indicators when dipped into the substances.
3. Carry out the experiment below.

### *Apparatus and reagents*

Three test tubes, blue and red litmus papers, distilled water, hydrochloric acid and sodium hydroxide solution.

### *Procedure:*

1. Put about 10 cm<sup>3</sup> of water (A) acid (B) and base (C) in the three test tubes and label the test tubes.
2. Immerse red litmus paper into the solutions. Let the set up stand for some time. Make your observations.
3. Remove the red litmus paper and replace with blue litmus paper. Make your observations.
4. Record your observations in a table like this

Litmus	Acid	Base	Water
Red			
Blue			

5. Discuss your results in your group then make a presentation to the rest of the class.

### *The Facts*

There are many chemicals that appear like one another. For example, it is difficult to distinguish between distilled water and an acid solution. Equally, it is hard to distinguish between distilled water and an acid solution. Equally, it hard to distinguish between an acid and a base or alkali. Indicators are substances that we use to distinguish between acids and bases. They can be manufactured (commercial indicators). An example of an indicator are the red and blue litmus papers. Acid solutions turn blue litmus paper red but have no effect on red litmus paper. On the other hand, basic solutions (alkali) turn red litmus paper blue. However, neutral solutions like distilled water have no effect on both red and blue litmus papers.

### Activity 3.3

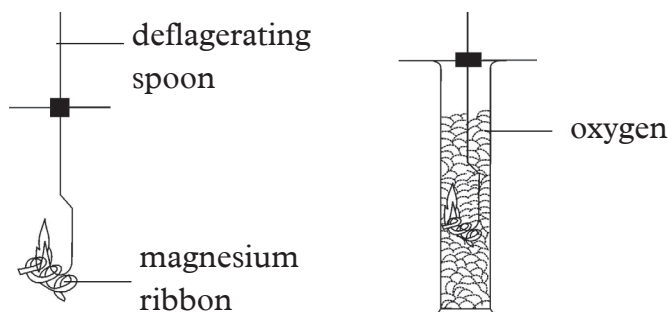
*In groups of five:*

#### **Apparatus and reagents:**

- Magnesium ribbon, sodium metal, deflagrating spoon, chlorine gas in a gas jar, tongs, test tubes.

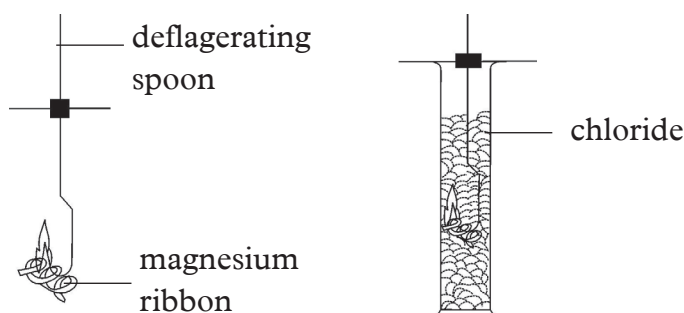
#### **Procedure**

1. Cut 5cm of magnesium ribbon, fold it and put in a deflagrating spoon.
2. Light the ribbon and insert inside a glass containing oxygen. Observe the production formed.



*Fig 3.2*

3. Cut a small piece of sodium metal, put in a deflagrating spoon. Insert the burning sodium inside the gas jar containing chlorine. Observe the product formed.



*Fig 3.3*

4. Discuss the two products formed in the experiments.

#### **The Facts**

Sodium and magnesium burn to form salts. Also, acids and bases react to form salts and water. For example, hydrochloric acid reacts with sodium hydroxide (base) to form sodium chloride (table salt) and water only. A salt is therefore defined as the product that is formed when acids react with bases.

## 3.2 Properties of acids and bases

### Activity 3.4

#### *Experiment to determine properties of acids*

##### *Apparatus and reagents*

Dilute hydrochloric acid, litmus paper (blue and red), oranges, vinegar, lemon, paper, concentrated sulphuric acid, test tubes, magnesium ribbon, sour milk and nitric acid.

##### *Procedure*

1. Taste these substances and record your observations in a table.

Substance	Taste (bitter, sour)
Sour milk	
Oranges	
Vinegar	
Lemon	

2. Drop a piece of magnesium ribbon into a test tube containing dilute hydrochloric acid. Write down what you observe.
3. Place some concentrated sulphuric acid in a test tube. Drop a piece of paper in the acid. Record your observations.
4. Drop blue and red litmus papers in dilute hydrochloric acid contained in a test tube. What do you observe?
5. Add phenolphthalein and methyl orange indicators to nitric acid in different test tubes. What do you observe?

### *The Facts*

#### *The following are the properties of acids:*

1. Acids have **sour taste**.
2. Acids turn blue litmus paper red.
3. A piece of paper placed in concentrated sulphuric acid gets charred. This is because acids are **corrosive**.
4. When magnesium ribbon is dropped in dilute hydrochloric acid, bubbles of a colourless gas are seen. This shows that dilute acids react with metals to produce **hydrogen gas** as one of the products.

### Activity 3.5

#### *To determine properties of bases*

##### *Apparatus and reagents*

Test tubes, droppers, sodium hydroxide solution, dilute hydrochloric acid litmus papers, phenolphthalein indicator, methyl orange indicator.

##### *Procedure*

1. Add pieces of litmus paper to sodium hydroxide solution. Record your observations.
2. Put  $2\text{cm}^3$  of dilute sodium hydroxide solution in a beaker. Add two drops of phenolphthalein to the beaker. Compare the colour of the solution to the PH indicator chart. Record the colour and corresponding PH. Repeat this using methyl orange indicator. Add drops of dilute sodium hydroxide until it returns to its original colour. Record your observations use the litmus paper to test the PH and record.
3. Put  $2\text{cm}^3$  of sodium hydroxide in a beaker. Add 5 drops of universal indicator to the beaker. Record your observations put another  $2\text{cm}^3$  of hydrochloric acid in a different beaker. Add 3 drops of universal indicator. Record observations.
4. Use a dropper to add  $2\text{cm}^3$  of the hydrochloric acid in the beaker into the  $2\text{cm}^3$  sodium hydroxide. Note the colour change and PH.
5. Add an additional  $2\text{cm}^3$  of hydrochloric acid into the sodium hydroxide and hydrochloric acid mixture until the solution changes colour and becomes neutral. Note the PH change.

### Activity 3.6

Your teacher will bring a variety of substances for you to test.

Predict the PH of the substances before you carry out the experiment and record. Dip blue and red litmus papers in the solutions of the substances provided. Write your observations.

Substance	Blue litmus	Red litmus
A		
B		
C		
D		

3. Add phenolphthalein indicator and methyl orange indicator to two separate solutions of each substance. Write down your observations.

4. Based on the results of these experiments. Group the substances as either acids or bases. Do a presentation to the rest of the class.

**Note:** Do not contaminate the substances being tested. Ensure you use different droppers for each substances.

### The Facts

*Table 3.4 Summary of properties of acids and bases*

Acids	Bases
Have sour taste.	Have bitter taste and soapy feel.
Are corrosive.	Are corrosive.
Turn blue litmus red.	Turn red litmus blue.
React with bases to form salt and water only.	React with acids to form salt and water only.

## 3.3 Strong, weak acids and bases

### Activity 3.7

#### *Apparatus and chemicals*

4 test tubes, 4 droppers, 2M hydrochloric acid, 2M ethanoic acid, 2M sodium hydroxide, 2M ammonia solution, universal indicator solution, pH chart, test tube rack, 10cm<sup>3</sup> measuring cylinders.

#### *Procedure*

Predict the colour you will observe when a universal indicator is added in an acid and base. Record your predictions.

1. Place about 20 cm<sup>3</sup> of dilute hydrochloric acid, ethanoic acid, sodium hydroxide solution and ammonia solutions in different beakers.
2. Add 2 - 3 drops of universal indicator solution. Note the colour of the solution.
3. Compare the colour of each solution with colours given on the universal indicator standard colour chart to determine the pH values.
4. Record the pH values in your notebook.
5. Classify the solutions as strong or weak acid and base.
6. From your prediction, was the colour correct? Were there any different colours formed in different acids and bases? Explain your answer.

## The Facts

Strong acids have high acidity and their pH values range from 1 — 3.5. Weak acids have their pH range from 3.5 — 6.5. Pure water has a pH value of 7.0 and it is said to be **neutral**.

Weak bases have their pH values ranging from 7.5 —10.5. Strong bases have a high alkalinity with pH values range from 10.5 –14.

The pH of dilute hydrochloric acid shows that it is a strong acid while that of ethanoic acid shows that it is a weak acid. The pH of dilute sodium hydroxide solution shows that it is a strong base while that of dilute ammonia solution shows that it is a weak base.

### Activity 3.8

#### *To determine whether acids and bases conduct electricity*

##### **Apparatus and chemicals**

250 cm<sup>3</sup> beaker, two 1.5 V dry cells, 2.5 V bulb, carbon rods, connecting wires, switch, 2M hydrochloric acid, 2M ethanoic acid, 2M sodium hydroxide, 2M ammonia solution, 50cm<sup>3</sup> measuring cylinder.

##### **Procedure**

In groups, discuss whether acids or bases conduct electricity. Given that acids and bases dissociate into their respective ions when dissolved in water. Do you think both strong/weak acids and base conduct electricity?

1. Put 50 cm<sup>3</sup> of 2M hydrochloric acid in the beaker.
2. Make a complete circuit using carbon electrodes as shown in Fig. 3.4.

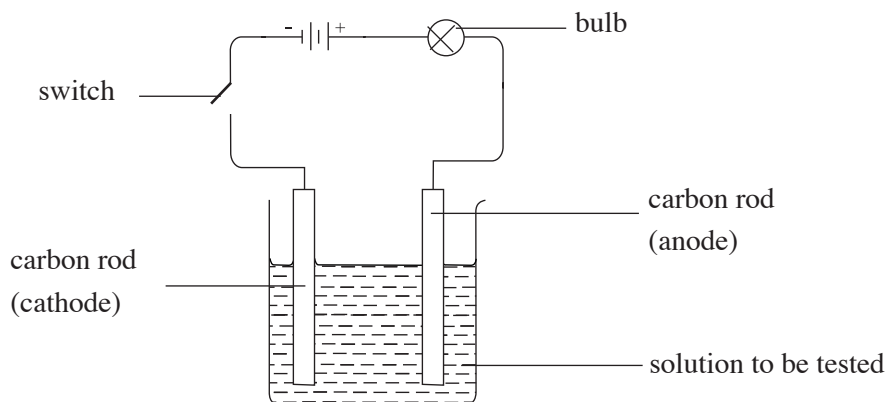


Fig. 3.4: Investigating the electrical conductivity of solutions

3. Switch on the current.
  - Does the bulb glow?
  - Note the intensity of the light given out?
  - What do you observe on the carbon rods? What does this indicate?
4. Repeat the same experiment with 2M ethanoic acid, 2M sodium hydroxide and 2M ammonia solution. Use 50 cm<sup>3</sup> of each solution.

Note: Rinse the beaker and the rods thoroughly with distilled water before adding the next solution.



- Note the changes occurring around the carbon rods and brightness of the bulb.
- Were you able to get the same results as your other group members? Compare your predictions to your practical results. Explain why there was a difference in the light intensity.

### The Facts

When bases, and acids are dissolved in water, their molecules dissociate to form ions which are able to conduct electricity. The higher the number of ions in solution the greater the electrical conductivity of the aqueous solutions making the bulb glow much more brightly. In the experiment above, the solutions which made the bulb to light brighter are strong acids and bases. Those which made the bulb dim are weak acids and bases.

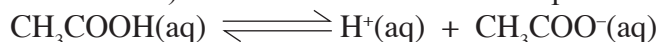
#### (a) Strong and weak acids

Acids are described as strong or weak depending on their ability to give the hydrogen ions when dissolved in water (aqueous solution), that is, the degree to which they dissociate into ions in aqueous solution.

**A strong acid is one which dissociates completely in water to give all its hydrogen ions.** They have high concentration of hydrogen ions. For example;



**A weak acid dissociates partially in aqueous solution.** That is, it forms very few hydrogen ions (low concentration) when dissolved in water. Examples are ethanoic acid and carbonic acid.



**Note:** ( $\rightleftharpoons$ ) show that the acid is weak and the process is reversible.

A weak acid contains more molecules than the ions in its aqueous state.

#### (b) Strong and weak bases

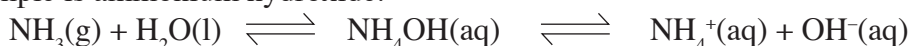
A base is described as strong or weak depending on the extent to which it yields the hydroxide ions when dissolved in water.

**A strong base is one which completely dissociates to give all its hydroxide ions in aqueous solution.** For example

Sodium hydroxide and potassium hydroxide are examples of strong bases.



**A weak base partially dissociates to give few hydroxide ions in aqueous solution.** An example is ammonium hydroxide.



### Check your progress 3.1

- (a) Distinguish between
  - A strong and weak acid
  - A strong and a weak base
  - Give examples in each case.(b) Hydrochloric acid is naturally found in the stomach. What role does it play in the stomach?
- Fill the table below appropriately with any of these words: natural, commercial, both natural and commercial.

Acid	Type
(a) Acetic acid	
(b) Hydrochloric acid	
(c) Sulphuric acid	
(d) Carbonic acid	
(e) Nitric acid	

- Given the following list of some household products, classify them into either acids or bases: Yorghut, pineapple, toothpaste, limewater, limejuice and baking soda.
- State whether the statements below is either **true** or **false**.
  - All acids and bases conduct electricity.
  - The acidity and basicity of a substance is determined using the universal indicator.
  - Acids and base react to form salt.
- How would you know that a certain solution is an acid or a base? Explain.
- Use a table to complete the differences between acids and bases .

### 3.4 Simple acid–base indicators

#### Activity 3.9

Research using reference materials the meaning of acid-base indicators.

## The Facts

Indicators can be classified as either naturally occurring or commercial indicators. The most common commercial indicator is **litmus**. Litmus is a blue vegetable compound, which is extracted from **lichens**. Litmus shows a **blue colour** in an alkali and a **red colour** in an acid. Other commonly used commercial indicators are **phenolphthalein** and **methyl orange**.

Many other plant materials contain dyes which can be used as acid-base indicators as well. Examples are leaves of red cabbages, coloured flower petals of hibiscus or bougainvillea among others. They show one colour in an acidic solution and another different colour in an alkaline solution.

### Activity 3.10

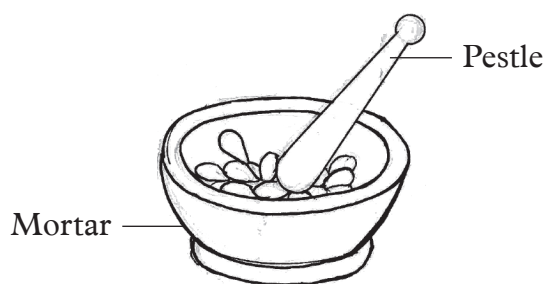
*Experiment to prepare an acid-base indicator from red cabbages*

#### *Apparatus and reagents*

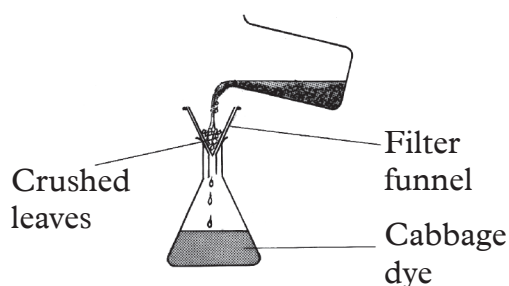
Red cabbage leaves, filter funnel, conical flask, test tubes, beaker, tapwater, filter paper, motor and pestle, hydrochloric acid, potassium hydroxide, dilute sulphuric acid and boiling water.

#### *Procedure*

1. Cut off two leaves of red cabbage into tiny pieces.
2. Crush the tiny pieces of red cabbage leaves in mortar using the pestle. Add boiling water as you continue crushing. This helps to extract as much dye from the leaves as possible.
3. Allow the small pieces of red cabbage leaves to stand in the water until it becomes purple coloured. This may take an hour. Transfer the contents into a beaker.
4. Filter the mixture into a clean conical flask. What is the colour of the filtrate?

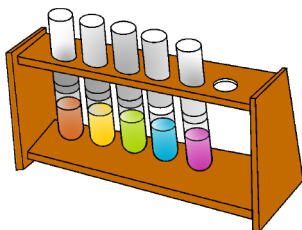


*Fig 3.5: Motor and pestle*



*Fig 3.6: Filtration*

5. Add three drops of the red cabbage extract into five test tubes containing water, hydrochloric acid, sodium hydroxide, potassium hydroxide and dilute sulphuric acid. Record your observations.



*Fig 3.7: Test tube rack*

6. Classify the solutions in the test tubes as acidic, basic or neutral. Summarise your results in the following table.

Substance	Colour of red cabbage extract in the substance.	State whether acid, base or neutral
Water		
Hydrochloric acid		
Sodium hydroxide		
Potassium hydroxide		
Dilute sulphuric acid		

### *Study Questions*

1. Why do we cut the red cabbage leaves into small pieces?
2. What is the role of boiled water in this experiment?
3. What is the colour of the cabbage extract?
4. How can you make the extracted indicator solution more concentrated?

### *The Facts*

Plant extracts can be used as acid-base indicators. Red cabbage leaves or flower extracts are such examples. Other coloured parts of plants such as beetroots can also be used to make similar indicators. However these extracts have a disadvantage in that their colours change over time.

In the laboratory, commercial indicators that give more consistent results are commonly used as acid-base indicators. Examples of commercial indicators include litmus, methyl orange, phenolphthalein and screened methyl orange. They are manufactured for sale by various chemical-producing companies and supplied to laboratories for use. Unlike laboratory-made indicators, commercial indicators can be used over a long period of time and still give consistent results.

### Activity 3.11

#### *Experiment to determine level of acidity and basicity*

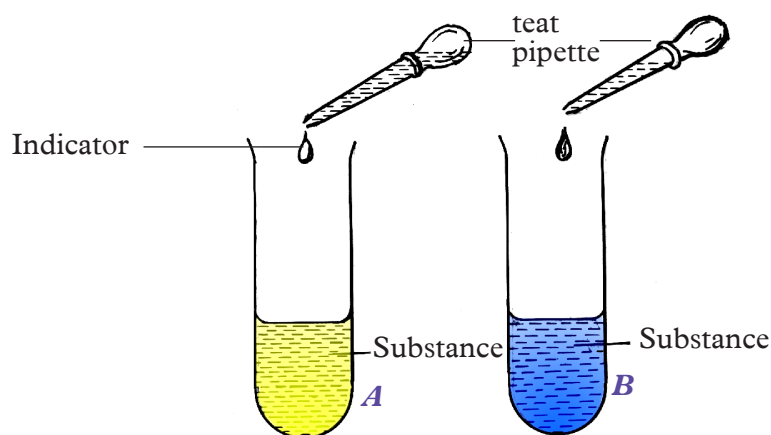
#### ***In groups:***

#### **Apparatus and reagents**

All the commercial indicators available, test tubes, dilute hydrochloric acid, orange juice, dilute sulphuric acid, sodium hydroxide solution, potassium hydroxide solution, water, ammonia solution and soap solution.

#### **Procedure**

1. To four separate test tubes, add  $1\text{ cm}^3$  of dilute hydrochloric acid.
2. To the first test tube, add 2 drops of the litmus solution. To the second test tube, add 2 drops of phenolphthalein indicator. To the third and fourth test tubes, add 2 drops of methyl orange and screened methyl orange respectively.
3. Predict the colour change of each solution after adding the indicators



*Fig 3.8: Identifying substances using indicators*

3. Record your observations in a table.
4. Repeat the experiment using soap solution, orange juice, sulphuric acid, sodium hydroxide, potassium hydroxide, water and ammonia solution; instead of hydrochloric acid. Record your results in a table.
5. Were your predictions correct compared to the experiment results?

#### ***Study questions***

1. What is the colour of each indicator in:  
(a) Acidic solution?                      (b) Alkali?                      (c) Neutral solution?
2. Write a report and present it to the class.

### The Facts

The experiment above shows that different indicators show different colours under different conditions. Table 3.5 gives a summary of these colours.

Table 3.5: Colours of different solutions in different indicators

Indicator Solution Tested	Litmus Solution	Phenolphthalein	Methyl Orange	Screened Methyl Orange
Hydrochloric acid	Red	Colourless	Pink	Purple
Sulphuric acid	Red	Colourless	Pink	Purple
Sodium hydroxide	Blue	Pink	Yellow	Orange
Potassium hydroxide	Blue	Pink	Yellow	Orange
Water	Purple	Colourless	Orange	Grey
Ammonia solution	Blue	Pink	Yellow	Orange

## 3.4 The pH scale

### Activity 3.12

#### Research activity

Individually, find out the following:

1. While at home, what are some of the things you use in the cultivation of crops to ensure an abundant harvest?
2. Why do we add slaked lime or gypsum to certain soils?
3. What are the effects of adding slaked lime or gypsum to the soil?
4. Why is it important to take samples of soil to the laboratory for testing before a farmer begins cultivation?

### The Facts

Soil testing is important as it enables farmers to determine the soil pH. This helps them make the right choice of the crop to plant.

After cultivation, appropriate measures are taken, such as addition of lime so as to lower acid levels or addition of gypsum to increase acidity of the soil. The pH of a solution is a **measure of the acidity or alkalinity of the solution**.

### Activity 3.13

#### Experiment to determine pH of different substances

##### *In groups:*

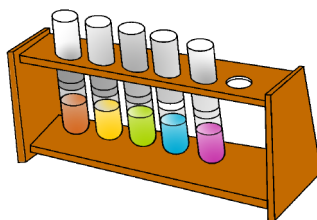
##### *Apparatus and reagents*

Dilute hydrochloric acid, dilute sulphuric acid, sodium hydroxide solution, distilled water, ammonia solution, calcium hydroxide, lemon juice, rainwater, test tubes, universal indicator, pH scale and droppers.

##### *Procedure*

Predict the PH of each substance before you carry out the experiment and also say whether it is a strong acid or neutral or weak and base.

2. Place 1 cm<sup>3</sup> portions of dilute hydrochloric acid, dilute sulphuric acid, sodium hydroxide solution, ammonia solution, calcium hydroxide, distilled water, lemon juice and rainwater into different test tubes.
3. To each test tube, add 3 drops of the universal indicator and observe the colour of the solution.



*Fig 3.9: Test tubes containing different solutions*

4. Place each test tube and its contents against a pH chart. Match the colour of the indicator in the solution against the shade on the pH chart and record the pH value of each solution in a table.

Solution	Colour of universal indicator in the solution	pH value
Hydrochloric acid		
Sulphuric acid		
Sodium hydroxide		
Distilled water		
Ammonia solution		
Calcium hydroxide		
Rain water		
Lemon juice		

5. Compare your predictions to your experimental results. Were your predictions correct.

## The Facts

The pH values for acids range from zero to just below seven. Substances such as rainwater and lemon juice are considered acidic and have pH values, which range between 4 and 7. They are said to be **weak acids**. Solutions of hydrochloric acid and sulphuric acid have pH values, which range between 0 and 4. These solutions are said to be **strong acids**. As the pH values decrease from 7 to 0, the strength of acids increase. A pH value of 7 implies the solution is neither acidic nor basic and it is hence said to be **neutral**. Distilled water is neutral hence has a pH of 7. The pH values of bases range between 7 and 14. Ammonia solution and calcium hydroxide solution have pH values between 7 and 10 and are said to be **weak bases**. An example of a naturally occurring weak base is wood ash. Sodium hydroxide and potassium hydroxide solutions have pH values above 10 and are said to be **strong bases**. As the pH values increase from 7 to 14, the strength of the bases also increase.

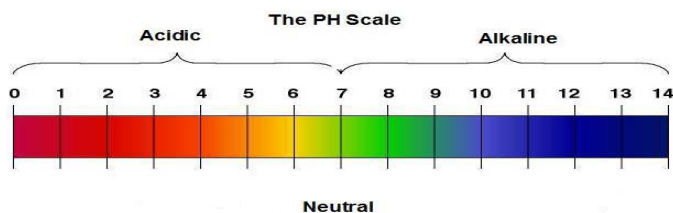
The universal indicator is a mixture of several indicators and it shows a range of colours in acids and bases depending on the **degree of acidity or alkalinity**. Some acids are more acidic than others while some bases are more basic than others.

By use of a universal indicator and the pH chart, we can get the pH values of various solutions.

### Quality check!

*Before buying universal indicators to be used in the laboratory always check to confirm that they meet the standards and are not expired.*

The pH scale measures how acidic or basic a substance is. It has numbers ranging from 0 to 14. A pH of 7 shows that a solution is neutral while a pH below 7 shows that a solution is acidic. A pH higher than 7 indicates that a solution is basic.



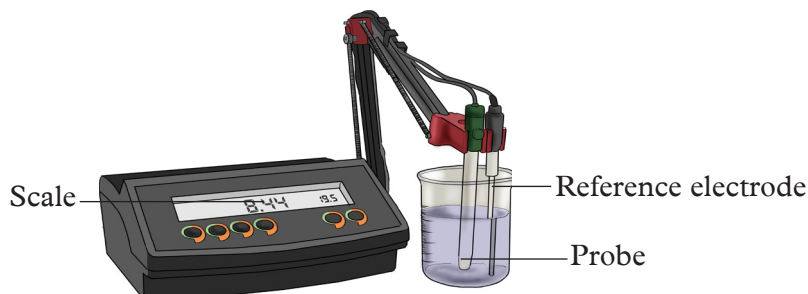
*Fig 3.10: Example of a standard pH colour chart*



## The a pH-meter

### Activity 3.14

Your teacher will bring a pH meter in **class** for you to observe and use.



*Fig 3.11: A pH metre*

1. Observe the pH meter carefully. (Be careful not to break the apparatus)
2. Compare it to the chart given by your teacher.
3. Draw and label the various parts of the pH meter.
4. Use the pH meter to determine the pH of the solutions provided in activity 3.11.
5. Use the readings to group the solutions as strong or weak acids and bases.

### The Facts

A pH meter is used to make rapid and accurate measurements of pH of various solutions or substances. A pH meter is made up of two electrodes one of which is the **reference electrode** connected to a multi-voltmeter and the second one called the **probe**. Both are dipped into the solution being tested. The result is directly converted into pH and shown on the screen. The electrodes have to be rinsed in distilled water before being dipped into another solution of unknown pH for testing. pH meters are usually used in hospitals to determine the pH of blood and urine samples for diagnostic purposes.

### Check your progress 3.2

- Describe how you would prepare an indicator in the laboratory from hibiscus flowers. What apparatus do you need? What steps will you follow?
- Name three commercial indicators commonly found in the laboratory.
  - State the colour changes of the indicators named in 2 (a) in acidic, basic and neutral solutions.
- Why do you think the knowledge of acidity levels in substances is important?
- A seed catalogue states the preferred soil pH ranges for plants as follows.

Type of plant	Preferred pH range
Heather	4.5 – 6.0
Violet	5.0 – 7.5
Primrose	5.5 – 6.5
Daffodil	6.0 – 6.5

- Which plant will grow over the largest pH range? (Show how you arrived at your Answer)
- At which soil pH will a gardener be able to grow all of these plants?
- Which of the plants can be grown in an alkaline soil? Explain.
- The soil in a garden has a pH of 4.5. Explain how a gardener can treat the soil in order to grow daffodils.

## 3.5 Uses of acids and bases

### Activity 3.15

- Look at the pictures below.



- Name the things in the pictures and state what they are used for. Prepare a report for presentation to the rest of the class.
- State other applications of acids and bases in our daily lives.

## The Facts

The pictures in Activity 3.15 show some applications of acids and bases.

### *Some applications of acids include:*

1. Hydrochloric acid is produced in the human stomach. It is used to aid in the process of digestion.
2. Sulphuric acid is used in car batteries, manufacture of plastics, pesticides, detergents and pharmaceutical products. It is also used in the manufacturing of some fertilisers.
3. Ethanoic acid in vinegar is used as a food seasoning.
4. Carbonic acid is added in soft drinks to enhance taste.
5. Nitric acid is used in the manufacture of nitrogenous fertilisers, explosives and in the manufacture of dyes and paints.
6. Phosphoric acid is used in the manufacture of phosphate fertilisers and making anti-rust paint.
7. Methanoic acid is used in kettle de-scalers.

### *Some applications of bases include:*

1. Ammonia solution is used in the manufacture of fertilisers and detergents.
2. Sodium hydroxide is used in the manufacture of soaps and detergents.
3. Ammonium hydroxide is used to make cleaning agents such as oven cleaners.
4. Magnesium hydroxide is used in the treatment of indigestion.
5. Calcium hydroxide is used as garden lime to reduce soil acidity and in the manufacture of cement and toothpaste.

#### Quality check!

*I will ensure that I buy only standard materials made of acids and bases. This way, I will avoid risks associated with sub-standard materials and save on costs!*

## Dangers associated with bases and acids

### *Note:*

It is not always that acids and bases are useful to us. Sometimes, they may cause harm.

### Activity 3.16

Research about some of the side effects of acids and bases. Write a report and present to class. Your report should include what should be done to avoid these side effects.



**Acids and bases cause a number of undesirable effects on the environment.**

**(a) Acid rain**

Industrial processes release acidic gases into the atmosphere. When gases, such as sulphur dioxide and nitrogen dioxide, accumulate in the atmosphere, they combine with rainwater to form what is called acid rain. Acid rain causes a number of environmental problems.

- It wears off buildings and structures made of limestone. Acids also rapidly corrode buildings made of metal.
- When surface run off resulting from acid rain adds to lakes and rivers, it kills aquatic animals and plants.
- Acid rain causes nutrients to be leached out of the soil and from leaves. Trees are thus deprived of these nutrients.
- Due to the rain, aluminium ions are freed from clays as aluminium sulphate resulting in damaged tree roots. The trees are unable to draw enough water through the damaged roots leading to death.

**My environment, my life!**

*Let us campaign against release of harmful gases to the atmosphere. This will reduce air pollution and even chances of global warming!*

**(b) Tooth decay**

Bacteria change foods that stick between teeth into acids. These acids dissolve the enamel leading to tooth decay; this eventually causes toothaches. Tooth decay begins when the pH in the mouth falls below 5.

**Note:** Toothpastes are alkaline in order to neutralise acids in the mouth.

**Health Check!**

*Let us brush our teeth at least twice a day to keep healthy!*

**(c) Stomach indigestion**

Dilute hydrochloric acid in our stomach helps in digestion of food. However when the stomach secretes excess of the acid, it causes indigestion. The acid burns the lining of the stomach hence causing ulcers.

**Note:** Antacid tablets contain mild base i.e magnesium hydroxide. This neutralises excess acidity in the stomach hence relieving pain.

### Quality check!

*Before you buy any medicine from the pharmacy ensure that it has not expired.*

#### (d) Soil pH

Plant growth is affected by the acidity or alkalinity of the soil. The degree of acidity depends on the concentration of hydrogen ions ( $H^+$ ) in the soil solution. When the concentration of the ions is very high, the soil is said to be acidic and it is very low then the soil is termed as basic. Soil acidity is also affected by excess use of fertilisers and acid rain. Acidic soil is unsuitable for growth of certain crops.

**Note:** If the soil is too acidic, it is treated by addition of lime. Lime base is a mixture of calcium oxide and calcium hydroxide, which neutralises excess acidity in the soil.

### Check your progress 3.3

- (a) What is pH of a solution?  
(b) The following table gives pH of some solutions.

Solution	pH center
A	3.0
B	5.2
C	5.0
D	11.0
E	12.5
F	7.0

Identify the substances that are acids and those that are bases.

- (c) Which solution:
  - Is the most basic?
  - Is the most acidic?
  - Will not affect universal indicators?
  - Is likely to be found in human stomach?
- Write whether **true** or **false**.
  - pH is a measure of hydroxide ion ( $OH^-$ ) concentration in a solution\_\_\_\_\_.
  - Universal indicator is a mixture of several indicators. \_\_\_\_\_.
  - Strong acids have pH between 4-7. \_\_\_\_\_.
  - Weak bases have pH between 8-10. \_\_\_\_\_.
  - pH meter is the same as pH chart. \_\_\_\_\_.

3. State the uses of the following acids and bases.
  - (a) Ethanoic acid
  - (b) Sulphuric acid
  - (c) Sodium hydroxide
  - (d) Ammonium hydroxide
4. Ammonium hydroxide is a base that is found in window cleaner. What precaution must you observe before using this product?

### 3.7 Types of salts

#### Activity 3.16

Discuss the questions below and write a report for presentation to the class. You can do research in the library or through the Internet. You can also use handouts and pamphlets provided by your teacher.

1. What do you understand by the term salt?
2. Name any five salts that you know.
3. Salts are named depending on the acid they are derived from. Considering this fact, give the missing information in the following table.

Acid	Base	Name of the resultant salt
Hydrochloric acid	NaOH	
Sulphuric acid	KOH	
Carbonic acid	Ca(OH) <sub>2</sub>	
Nitric acid	Mg(OH) <sub>2</sub>	

4. Write the formulae of the following salts based on the facts in step 3 above.

Salt	Formula
Potassium nitrate	
Sodium chloride	
Calcium sulphate	
Zinc chloride	
Potassium chloride	
Sodium sulphate	

5. Compare your work with other class members.

### The Facts

A salt is a compound formed when the hydrogen ions of an acid are wholly or partially replaced by a metal or ammonium ion. The process involves a **neutralisation** reaction in which a base neutralises an acid. When all the hydrogen ions of an acid are replaced by a metal or ammonium radical, we get a **normal salt**. All chloride and nitrate salts are normal salts. When the hydrogen ions of an acid are partially replaced, we obtain an **acid salt**.

The number of hydrogen atoms in each molecule of an acid, replaceable directly or indirectly by a metal or ammonium radical, is called the **basicity** of that acid. Both hydrochloric and nitric acids contain only one replaceable hydrogen atom hence are said to be **monobasic**. Monobasic acids form one series of salts i.e normal salts. Sulphuric and carbonic acids have two replaceable hydrogen atoms per molecule of the acid. They are **dibasic**. These acids form two series of salts.

(i) Where all hydrogen atoms of the acid are replaced a normal salt is formed.

Consider the following equation:



Note that zinc sulphate has no hydrogen atom which can be replaced. It is therefore described as a **normal salt**.

(ii) Where only a part of the hydrogen atoms of the acid are replaced an acid salt is formed.

Consider the following equation.



Note that sodium hydrogen sulphate salt still has **one hydrogen atom**, which can be replaced by a metal or ammonium ion. This is an acid salt.

**Note:** Names of salts are derived from the metal or ammonium ion from which they are formed and the parent acid. When naming salts the name starts with the metal or ammonium ion in the salt, followed by the respective acid radical. Table 3.6 gives examples of common salts from different acids.

**Table 3.6: Naming of salts from different acids**

Acid and its formula	Class of salt	Type of salt	Examples
Hydrochloric acid (HCl)	Chlorides	Normal	Sodium Chloride Calcium Chloride
Nitric acid (HNO <sub>3</sub> )	Nitrates	Normal	Potassium nitrate Lead(II) nitrate
Sulphuric acid (H <sub>2</sub> SO <sub>4</sub> )	Sulphates	Normal	Magnesium sulphate Lithium Sulphate
	Hydrogen sulphates	Acidic	Sodium hydrogen sulphate
Carbonic acid (H <sub>2</sub> CO <sub>3</sub> )	Carbonates	Normal	Zinc carbonate Calcium carbonate
	Hydrogen carbonates	Acidic	Calcium hydrogen Carbonate

### Check your progress 3.4

1. Match the acid with the salt name associated with it.

Acid	General name of the salts
(a) Nitric acid	Chlorides
(b) Hydrochloric acid	Sulphates
(c) Carbonic acid	Nitrates
(d) Sulphuric acid	Carbonates

2. State whether these acids form normal salts only or can form both normal and acid salts.

- (a) Carbonic acid                      (b) Hydrochloric acid  
(c) Sulphuric acid                      (d) Nitric acid

3. Complete the following equation and name the salt formed:

- (i) Sodium + nitric acid  $\longrightarrow$  \_\_\_\_\_  
 (b) Calcium + carbonic acid  $\longrightarrow$  \_\_\_\_\_  
 (c) Ammonium ion + hydrochloric acid  $\longrightarrow$  \_\_\_\_\_  
 (d) Potassium metal + sulphuric acid  $\longrightarrow$  \_\_\_\_\_

4. The table below gives examples of some salts. Give missing information in the table.

Name of salt	Formulae of salt	Source (acid)
Zinc nitrate	(a)	(b)
(c)	K <sub>2</sub> SO <sub>4</sub>	(d)
(e)	(f)	Hydrochloric acid
Ammonium sulphate	(g)	(h)



# UNIT 4

## Redox reactions

Learning outcomes		
Knowledge and understanding	Skills	Attitudes
<ul style="list-style-type: none"><li>• Understand redox reactions</li><li>• Know the activity series and understand its use in predicting displacement products.</li></ul>	<ul style="list-style-type: none"><li>• Investigate the oxidation state (oxidation numbers) and the degree of oxidation</li><li>• Use aqueous potassium iodide and acidified potassium permanganate (VII) to identify oxidizing and reducing agents</li><li>• Use information to identify patterns, report trends and draw inferences</li><li>• Present reasoned explanations for phenomena, patterns and relationships</li></ul>	<ul style="list-style-type: none"><li>• Adapt behaviour to suit different situations</li></ul>

### Introduction

The word redox is an abbreviation for reduction and oxidation reaction. The first three letters i.e RED are derived from 'reduction' and the last two i.e. 'OX' are derived from 'Oxidation'. Redox reactions therefore involve reduction and oxidation process.

## 4.1 Oxidation and reduction process

### Activity 4.1

#### To study the action of dry hydrogen on heated copper(II) oxide

1. Pass dry hydrogen gas over heated copper(II) oxide as shown in Fig.4.1. The following **precautions** must be taken when performing this experiment.
  - The combustion tube must be clamped in a slanting position.
  - Before lighting the gas at the end of the delivery tube, we must let hydrogen pass through until all the air is driven out.
  - When we stop heating, we must once again let a stream of hydrogen continue passing through the combustion tube until it has cooled.

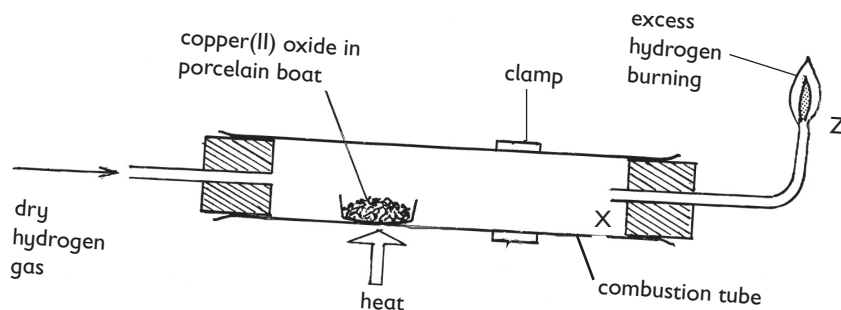


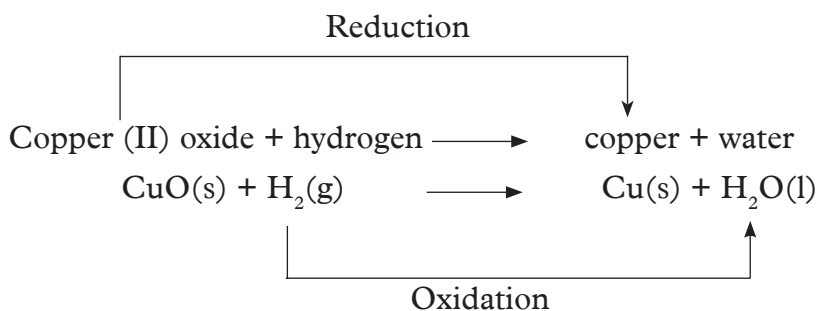
Fig.4.1 Reducing copper(II) oxide with hydrogen

#### Study questions

- (a) What change do you observe on copper(II) oxide during the experiment?
  - (b) What do you observe in the combustion tube at point **X**?
  - (c) Why is hydrogen gas burned at point **Z**?
2. Repeat the experiment using lead(II) oxide. Record your observations.

### The Facts

During the reaction, copper(II) oxide loses oxygen. Therefore copper is reduced. Hydrogen gas gains this oxygen, so it is oxidised. Oxidation is therefore gain of oxygen or loss of hydrogen while reduction is gain of hydrogen or loss of oxygen. The above processes take place at the same time. That is why it is called a **reduction – oxidation** reaction, abbreviated as **Redox** reaction.



When the experiment is repeated with lead(II) oxide, a similar reaction takes place. The **yellow** lead(II) oxide changes to **red-brown** on heating. When the reaction is complete, grey lead metal is left in the porcelain boat.

Lead oxide + hydrogen  $\longrightarrow$  lead + water



**Note:** In both experiments, a colourless liquid is formed. It can be tested with anhydrous copper(II) sulphate to prove that it is water. Determination of its boiling point shows that it is pure water.

## Reaction of Iron III oxide with hydrogen gas

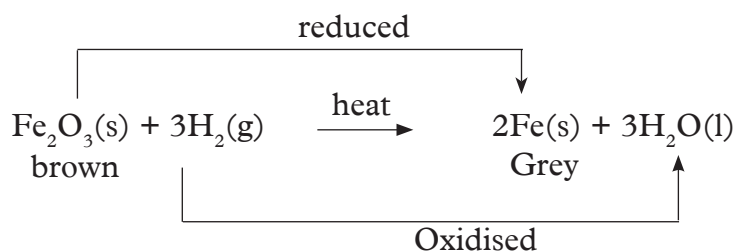
### Activity 4.2

#### *As a class:*

1. Write down the procedure to investigate a reaction between Iron III oxide and hydrogen gas as an example of redox reaction.
2. What observation and conclusions do you make?
3. What role does hydrogen play?
4. Write an equation for the reaction.

#### *The Facts*

Hydrogen gas reduces Iron (III) oxide to form Iron according to the equation below.



Therefore, hydrogen is oxidised whereas Iron is reduced.

## Other examples of redox reactions

### a) Reaction of metals with cold water

#### Activity 4.3

*To investigate the reaction of sodium with water*

**In groups:**

**Apparatus and chemicals**

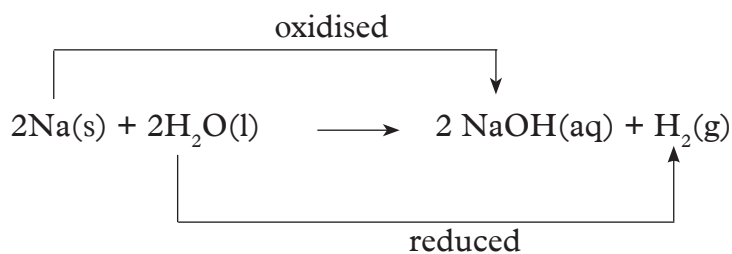
Pair of tongs, knife/scalpel, trough, universal indicator / suitable indicator, water.

**Procedure**

1. Half fill the trough with cold water.
2. Add three drops of the indicator.
3. What colour do you observe? Record the colour in your notebook.
4. Using a pair of tongs, remove a small piece of sodium from the bottle, place it on a ceramic tile covered with a filter paper to absorb excess oil.
5. Cut a very small piece of sodium and return the rest into the bottle.
6. Drop the small piece of sodium using either a knife or a scalpel into the water. What do you observe? Record your observations in your notebook.

#### The Facts

As we have already learnt, Alkali metals such as Sodium react with water liberating hydrogen gas. The resulting solution is alkaline. In this particular case, sodium hydroxide is formed.



This is also a redox reaction as sodium gains oxygen and water loses hydrogen.

## b) Reactions of metals with acids

### Activity 4.4

*To investigate the reaction of magnesium with dilute sulphuric acid*

**In groups:** Predict what will happen when magnesium reacts with dilute sulphuric acid. How can you test the products formed from the reaction?

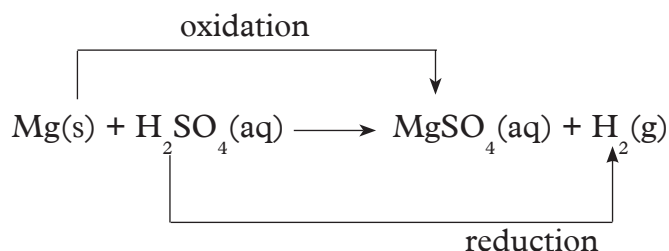
1. Using apparatus and chemicals below, come up with a procedure of investigating the reaction of magnesium with a dilute acid.

Boiling tube, bunsen burner / appropriate source of heat, wooden splint, 1M sulphuric acid, clean magnesium ribbon.

2. Compare your predictions with the experimental results. Which gas was produced? Explain your answer.

### The Facts

When a metal reacts with an acid, the reaction is a redox reaction. The metal atoms gain oxygen hence are oxidised while Sulphuric acid is reduced as per the equation below.



### Check your progress 4.1

1. Write an equation to show a redox reaction between
  - (a) Zinc and dilute sulphuric acid
  - (b) Iron and hydrochloric acid
2. A secondary One student carried out a redox reaction where by he added Sodium hydroxide solution to acidified Iron (II) sulphate followed by hydrogen peroxide solution.

A red-brown precipitate was formed. Write an equation of the reaction that took place. Support your equation with an explanation in terms of oxidation and reduction.

## 4.2 Oxidising and reducing agents

### Activity 4.5

#### Research Activity

#### Individually:

1. Find the meaning of:
  - (a) Oxidising agent
  - (b) Reducing agent
2. What are some of the examples of the above?
3. How can you distinguish between oxidising and reducing agents?

Write short notes and share with other members of your class.

#### The Facts

A reducing agent is a substance that reduces another substance by:

- removing oxygen from the substance
- giving hydrogen to the substance
- giving electrons to the substance

As it reduces other substances it itself becomes oxidised. Examples include:

- Potassium Iodide
- Reactive metals such as Zinc (Zn) and Magnesium (Mg)
- Hydrogen gas etc

Oxidising agent on the other hand is a substance that oxidizes another substance by:

- Giving oxygen to the substance
- Removing hydrogen from the substance
- Receiving electrons from the substance.

In the process, it gets reduced. Examples include:

- Acidified potassium permanganate
- Acidified potassium dichromate
- Halogens such as chloride
- Water

### Activity 4.6

*To investigate the reaction between an iron(II) compound and hydrogen peroxide*

#### In groups:

#### Apparatus and chemicals

Test tubes, test tube rack / beaker, boiling tube, glass rod, source of heat, Iron(II) sulphate or iron(II) chloride, 2M sodium hydroxide solution / aqueous ammonia, 2M sulphuric acid, twenty-volume hydrogen peroxide solution, distilled water.

### Procedure

1. Pour about 2cm<sup>3</sup> of freshly prepared iron(II) sulphate solution into a boiling tube.
2. Divide the solution into two portions.
3. To one portion, add a few drops of sodium hydroxide.
4. To the other portion, add a few drops of aqueous ammonia.
5. Record your observations in form of a table as in Table 4.1.
6. Repeat steps 1 and 2.
7. Add 1 cm<sup>3</sup> of 2M sulphuric acid to the iron(II) sulphate solution in the test tubes followed by about 0.5 cm<sup>3</sup> of 20 v/v hydrogen peroxide solution (if any effervescence occurs, it is some of the hydrogen peroxide decomposing to form Oxygen).
8. Divide the solution into two portions placed in test tubes.
9. Add a few drops of sodium hydroxide solution in one test tube and a few drops of ammonia in the other test tube. What do you observe?
10. Record your observations and conclusions as shown in Table 4.1

**Table 4.1 Experimental results**

Solution	Addition of sodium hydroxide	Addition of aqueous ammonia	Conclusions
(a) Iron(II) sulphate solution			
(b) Iron(II) sulphate solution + dil. sulphuric acid + hydrogen peroxide			

### The Facts

When sodium hydroxide solution or aqueous ammonia are added to freshly prepared iron(II) sulphate, a **green precipitate** of iron(II) hydroxide is formed. The green colour indicates the presence of iron(II), Fe<sup>2+</sup> ions. On the other hand, addition of sodium hydroxide solution or aqueous ammonia to acidified iron(II) sulphate followed by hydrogen peroxide solution forms a **red-brown precipitate** of iron(III) hydroxide. The red-brown colour indicates the presence of iron(III), Fe<sup>3+</sup> ions.

The equation of the reaction is



The reaction is therefore a **redox reaction**. This is because there is both gain and loss of oxygen and hydrogen. Oxidising agents gain hydrogen. Reducing agents lose oxygen. In the reaction above,  $\text{FeSO}_4$  is an oxidising agent while NaOH is a reducing agent. Other examples of oxidising agents which undergo a similar type of reaction as above include:

- Potassium iodide.
- acidified potassium manganate.
- acidified potassium per dichromate.
- concentrated sulphuric(VI) acid.

### Activity 4.7

#### *Investigating reducing property of potassium iodide*

#### **Work in groups:**

#### *Apparatus and reagents*

Potassium iodine solution, dilute sulphuric acid, gas jar of chlorine, starch solution, test tubes.

#### *Procedure*

1. Measure 5ml of potassium iodine solution, put it in a test tube and add equal amount of dilute sulphuric acid.
2. Pass chloride gas through the mixture and observe what happens.
3. Add a few drops of starch solution to the resultant solution in step 2 above. Observe what happens.
4. Record your observations and share with other groups.

#### *Study questions*

1. Account for the results in this experiment.
2. Comment about the need for starch solution in the experiment

### **The Facts**

Acidified potassium iodide reacts with chlorine to form a brown solution. This is because Iodine is displaced from the solution of potassium Iodide equation of the reaction is:



Chlorine which is an oxidising agent oxidises the potassium Iodine to free Iodine (brown solid). The Iodine then reacts with starch to give blue-black colour. This confirms presence of a reducing agent (KI)



## Activity 4.8

### *Investigating oxidising property of potassium permanganate*

#### **Work in groups:**

#### **Apparatus and reagents**

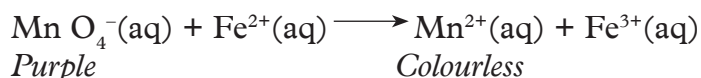
Potassium permanganate solution, dilute sulphuric acid, test tubes, Iron (I) sulphate solid, .

#### **Procedure**

1. Measure 5ml of potassium permanganate solution, transfer into a test tube and add equal amount of dilute sulphuric acid.
2. Add about 5 g of Iron (I) Sulphate into the test tube then heat gently
3. What happens after some time? Account for the results of this experiment.

### **The Facts**

The purple solution of potassium permanganate turns colourless. This is because the Iron (II) ions ( $\text{Fe}^{2+}$ ) reduce the manganate ( $\text{MnO}_4^-$ ) ions (purple) in solution to manganese ions ( $\text{Mn}^{2+}$ ) (colourless) i.e.



Similar reactions can occur with potassium dichromate as you shall learn later.

## 4.3 Oxidation numbers

Oxidation number, also called **oxidation state** is determined by the electrons gained, lost or shared during bond formation. The oxidation number is the value of the charge on the ion. Table 4.2 gives common ions and their oxidation numbers.

**Table 4.2 Oxidation number of some ions**

Ion	Oxidation number
$\text{Na}^+$	+1
$\text{Mg}^{2+}$	+2
$\text{Al}^{3+}$	+3
$\text{Cl}^-$	-1
$\text{O}^{2-}$	-2
$\text{P}^{3-}$	-3

## Activity 4.9

### Research Activity

#### Individually

Find out from the library or using the internet the rules that are followed when assigning oxidation numbers to elements. Write summarised notes and do a presentation to the rest of the class.

### The Facts

The following rules are followed when determining oxidation state of elements:

1. The oxidation number for an atom of any **free** (uncombined) **element** is zero, regardless of the atomicity. For example, atoms in  $\text{H}_2$ ,  $\text{O}_2$ ,  $\text{Cl}_2$ ,  $\text{K}$ ,  $\text{O}_3$  and  $\text{Fe}$  have zero(0) oxidation number.
2. The oxidation number for any simple one-atom ion is equal to its charge, thus the oxidation number of  $\text{K}^+ = +1$ ;  $\text{Ca}^{2+} = +2$  and of  $\text{Cl}^- = -1$ .
3. The oxidation number of hydrogen in non-ionic compound is +1. This applies to hydrogen compounds such as  $\text{H}_2\text{O}$ ;  $\text{HCl}$  and  $\text{CH}_4$  among others. For the **ionic** metal hydrides such as sodium hydride,  $\text{NaH}$ , the oxidation number of hydrogen is  $-1$ .
4. The oxidation number of oxygen is  $-2$  in all compounds e.g.  $\text{H}_2\text{O}$ ,  $\text{NO}$ ,  $\text{CO}_2$  etc except in peroxides e.g. in  $\text{H}_2\text{O}_2$  where it is  $-1$ . Another exception is  $\text{OF}_2$  in which oxygen atom has  $+2$  as its oxidation number.
5. The algebraic sum of the oxidation numbers of all atoms in the formula of a neutral compound must be zero. For example, in  $\text{H}_2\text{O}$  since the oxidation number of  $\text{H} = +1$  and  $\text{O} = -2$ , it follows that the oxidation state of water ( $\text{H}_2\text{O}$ ) must be zero (0) i.e.  $(+1 \times 2) + (-2) = 0$ .
6. The algebraic sum of the oxidation numbers of all the atoms in a complex ion is equal to the charge on the ion. Thus in  $\text{NH}_4^+$  ion, if we add the oxidation number of  $\text{N}$  and the  $4\text{H}$  atoms, it must be equal to  $+1$ . In  $\text{SO}_4^{2-}$ , the sum of all the oxidation numbers must be equal to  $-2$ .

### Worked out examples

#### Example 1

What is the oxidation number of  $\text{Na}$ ,  $\text{Mg}$ ,  $\text{O}_2$ , and  $\text{N}_2$ ?

#### Solution

Zero (0) because these are uncombined elements.

### Example 2

What is the oxidation number of chlorine in

- (a)  $\text{Cl}_2$ ?
- (b)  $\text{HCl}$ ?
- (c)  $\text{HOCl}$ ?
- (d)  $\text{ClO}_3^-$ ?

### Solution

- (a) Zero

Note:• In (b) to (d), we will assign oxidation number of chlorine a value  $x$ , and write down an algebraic equation and solve for  $x$ .

- In (b) and (c), the algebraic sum of oxidation numbers must be equal to zero.
- From the rules above, the oxidation number of  $\text{H} = +1$  and  $\text{O} = -2$ .

(b)  $\text{HCl} = 0$   
 $+1 + x = 0$   
 $x = 0 - 1$   
 $= -1$

The oxidation number of chlorine is  $-1$

- (c) The oxidation number of  $\text{H} = +1$ ,  $\text{O} = -2$

$\text{HOCl} = 0$   
 $+1 + (-2) + x = 0 \Rightarrow -1 + x = 0$   
 $x = +1$

The oxidation number of chlorine is  $+1$

- (d) Rule number 6; sum of oxidation number of all atoms in a complex ion is equal to the charge on the ion.

$\text{ClO}_3^-$   
 $x + 3(-2) = -1$   
 $x + (-6) = -1$   
 $x = -1 + 6$   
 $= +5$

The oxidation number of  $\text{Cl}$  atom in  $\text{ClO}_3^-$  is  $+5$ .

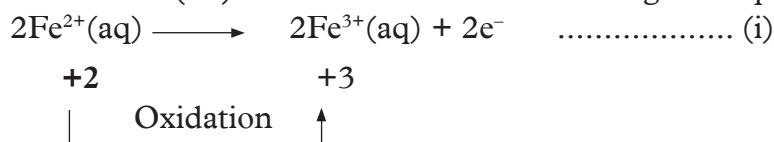
Oxidation numbers in Redox reactions

Here, we will consider the reaction between:

- Iron (II) ions and hydrogen peroxide
- Sodium and water
- Magnesium and dilute hydrochloric acid.

### (a) Reaction of iron(II) ions with acidified hydrogen peroxide

1. When iron(II) ions react with acidified hydrogen peroxide, iron(II) ions are oxidised to iron(III) ions as shown in the following half equations.

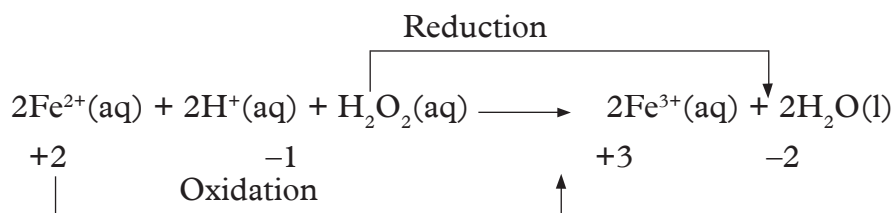


**Note:** The oxidation number has increased from +2 in  $\text{Fe}^{2+}$  ions (reactant) to +3 in  $\text{Fe}^{3+}$  ions (product). An increase in oxidation state is an **oxidation** process. Equation (i) is therefore an **oxidation reaction**. The other equation is:



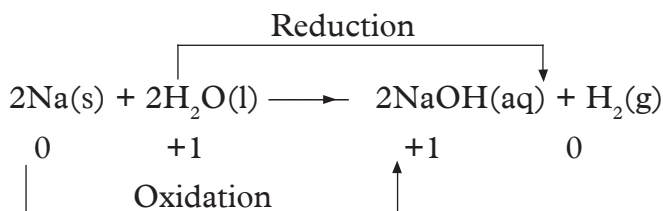
The oxidation state of oxygen has decreased from -1 in hydrogen peroxide ( $\text{H}_2\text{O}_2$ ) to -2 in water ( $\text{H}_2\text{O}$ ). A decrease in oxidation state is a **reduction** process. Equation (ii) is therefore a **reduction reaction**.

In overall equation



### (b) Reaction of sodium with water

The equation of the reaction is:



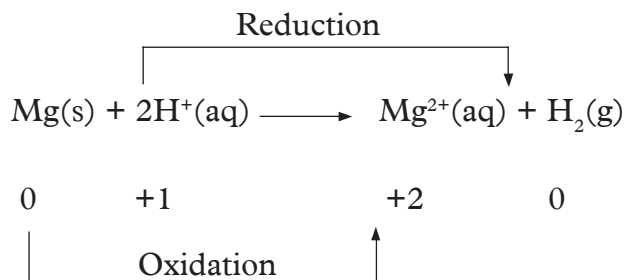
Sodium is oxidised because its oxidation state changes from a lower number(0) to a higher oxidation state (+1). The oxidation state of sodium has therefore increased. Hydrogen is reduced since its oxidation number decreases from (+1) to (0).

### (c) Reaction between magnesium and dilute hydrochloric acid

The equation of the reaction is:



Ionic equation is,



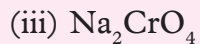
The oxidation number of magnesium increases from 0 to +2. This is oxidation. The oxidation number of hydrogen ions,  $\text{H}^+$ , decreases from +1 to zero. This is reduction.

**Note:** The oxidising agent gets its oxidation number decreased while the reducing agent gets its oxidation number increased.

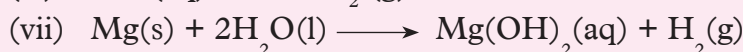
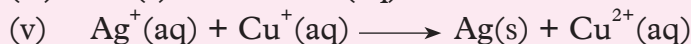
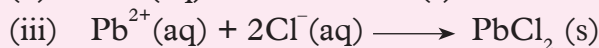
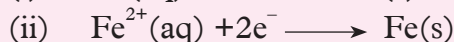
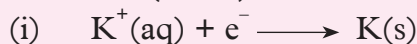
#### Check your progress 4.2

- Distinguish between
  - Oxidation and reduction.
  - Oxidising and reducing agentsGive examples in each case
- What are the oxidation numbers of nitrogen in the following.
  - $\text{N}_2\text{O}$
  - $\text{NO}_2$
  - $\text{NO}_3^-$
  - $\text{NO}$
- Determine the oxidation number of sulphur in the following.
  - $\text{H}_2\text{SO}_4$
  - $\text{SO}_2$
  - $\text{SO}_3^{2-}$  and  $\text{SO}_4^{2-}$
  - $\text{H}_2\text{S}$
- What is the oxidation number of manganese in the following?
  - $\text{KMnO}_4$
  - $\text{MnO}^-$
  - $\text{MnO}_2$
- Find the oxidation number of the underlined element and give systematic names of the following compounds:
  - Cu $\text{SO}_4$
  - Fe $\text{Cl}_3$
  - Mn $\text{SO}_4$
  - Cu $_2\text{O}$

6. What is the oxidation number of chromium, (Cr), in each of the following compounds?



7. Which of the following reactions are oxidation reactions, both oxidation and reduction (redox) and which are none? Explain.



## 4.4 The reactivity series

### Activity 4.10

#### *Work in pairs*

#### *Requirements*

- Gas jar of oxygen, deflagrating spoon, match box.
- Metals such as magnesium, sodium, calcium, iron and copper.

#### *Procedure*

1. Get a piece of each metal and place in a deflagrating spoon.
2. Ignite the metal using the matchstick then lower into the gas jar of oxygen.
3. Record your observations.

#### *Study questions*

- In which case was the reaction most vigorous?
- Why do you think this is the case?

3. Record your observations.

### *Study questions*

- In which case was the reaction most vigorous?
- Why do you think this is the case?

### *The Facts*

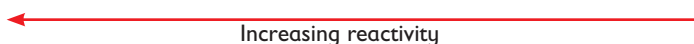
In the experiments above, sodium reacts most vigorously with oxygen, followed by calcium and then magnesium. Copper reacts with oxygen with the least vigour. This means that some metals have greater affinity for oxygen than others.

An element that reacts more vigorously with oxygen has a greater affinity for it, than one that reacts less vigorously.

The readiness or manner with which metals react with oxygen, or their affinity for oxygen, gives a series called **reactivity series**. It is a list of metals beginning with the most reactive at the top followed by the least reactive at the bottom.

From the experiment above come up with a reactivity series. Did it look like this?

Sodium , Calcium, Magnesium, Iron, Copper



Increasing reactivity

(most reactive)

(least reactive)

### **Competition for combined oxygen**

We can perform other experiments to help us come up with a reactivity series.

#### **Activity 4.11**

*Burning of magnesium with carbon (IV) oxide*

**Work in groups of four:**

**Apparatus and chemicals**

- Magnesium ribbon, gas jar, tongs, dry carbon dioxide

**Procedure**

1. Fill a gas jar with dry carbon dioxide.
2. Plunge a piece of burning magnesium into the gas jar.
3. Record what you observe.
4. Rub the side of the gas jar with a clean index finger. What do you notice on your finger?

### *The Facts*

Magnesium ribbon continues to burn with a splattering flame when put in a gas jar full of dry carbon dioxide. Black specks form on the sides of the jar and a white ash forms as well. The black specks are carbon particles, while the white ash is magnesium oxide.

**Questions:** Why does magnesium continue burning in dry carbon(IV) oxide yet carbon(IV) oxide does not support burning?

Magnesium continues to burn in carbon dioxide because burning magnesium produces enough heat to decompose carbon dioxide into carbon and oxygen. This reaction is shown by the word equation below.

heat

Carbon dioxide  $\xrightarrow{\text{heat}}$  carbon + oxygen

The oxygen so produced supports the burning of magnesium to form magnesium oxide. This experiment shows that magnesium has **displaced** (removed) oxygen from carbon dioxide. Therefore magnesium is more reactive towards oxygen than carbon.

### Activity 4.12

*To investigate competition for combined oxygen by metals.*

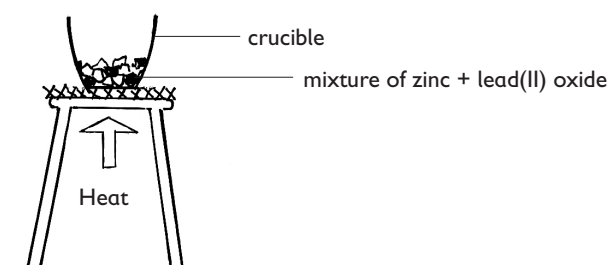
**In groups:**

*Apparatus and chemicals*

Bunsen burner, Tripod stand and wire gauze, Crucible, Oxides: magnesium oxide, copper(II) oxide, iron(III) oxide, lead(II) oxide, zinc oxide, Metals: zinc, magnesium, copper, iron, lead.

**Procedure**

1. Place one spatula end of zinc powder in a crucible.
2. Add a spatula full of lead(II) oxide and mix well.
3. Heat the mixture as shown in figure 4.4.
4. Copy Table 4.3 and record your observations.
5. Repeat steps 1-4 using magnesium powder and metal oxides paired with it as shown below.
  - (a) Magnesium + copper(II) oxide
  - (b) Magnesium + lead(II) oxide
  - (c) Magnesium + iron(III) oxide
  - (d) Magnesium + zinc oxide
6. Repeat the experiment with copper, iron and lead with the oxides as shown in Table 4.3.



*Fig. 4.2 Investigating competition of metals for combined oxygen*



**Table 4.3 Competition of metals for oxygen**

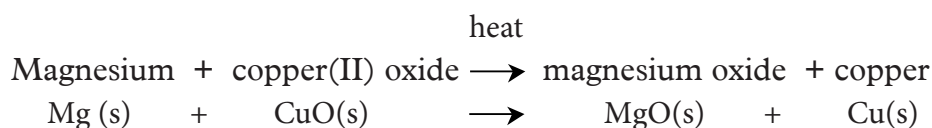
		Metal oxides				
metal		Copper(II) oxide	Lead(II) oxide	Zinc oxide	Iron(III) oxide	Magnesium oxide
	Colour of oxide					
Zinc						
Magnesium		Black colour turns white ash and red-brown solid	Yellow solid turns to red-brown then to yellow grey beads of lead and white ash	White solid changes to yellow then white and grey solid	Red -brown solid turns to white ash and grey-black metal	No colour change
Copper						
Iron						
Lead						

7. After you have filled the table, arrange the metals in order of their power to remove combined oxygen starting with the most powerful.
- What happens when a metal is heated with its metal oxide?

### The Facts

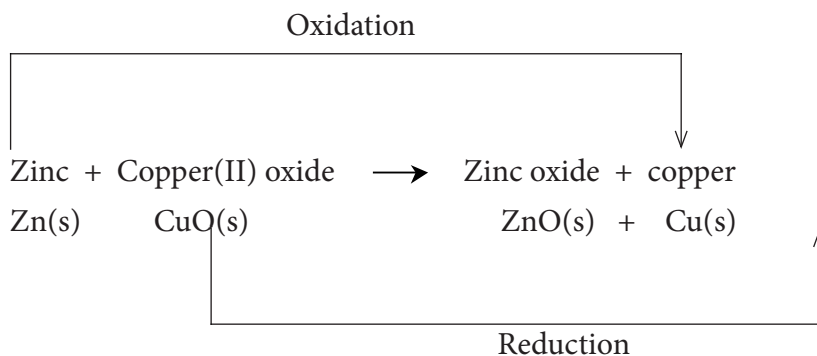
The colour changes observed in Table 4.3, when some metals are heated with oxides of different metals indicate that reactions took place. Let us look at what happens when we heat magnesium with copper(II) oxide.

The reaction can be represented in form of a word equation as follows:



In the above reaction, magnesium removes oxygen from copper(II) oxide. It gains the oxygen and becomes **oxidised**. On the other hand, copper(II) oxide loses oxygen. It is said to be **reduced**. The process of removing oxygen from a substance is called **reduction**. Addition of oxygen to a substance is called **oxidation**. In this case, magnesium is more reactive than copper. It has a higher affinity for oxygen than copper, so it removes the combined oxygen from copper(II) oxide.

In the example of Zinc and Copper (II) oxide, the following reaction occurs:



In this example, zinc **removes** oxygen from copper(II) oxide, that is, it **reduces** copper(II) oxide. Therefore zinc is referred to as the **reducing agent**. On the other hand, copper(II) oxide adds oxygen to zinc. It oxidizes zinc. Therefore, copper(II) oxide is the **oxidizing agent**.

From the results in these experiments, we can now arrange the five metals and carbon in order of their relative affinity towards combined oxygen. The metal with the highest affinity for oxygen is magnesium, and the one with the least affinity is copper. A list of elements with the most reactive at the top and the least reactive at the bottom can be developed as shown below. It is called the **reactivity series**.

Magnesium	↑	most reactive
Zinc		
Carbon		
Lead		
Copper		least reactive

**Note:** It is not practically possible to perform these types of reactions with all elements. Some elements are very expensive for ordinary laboratories like those found in schools. Others reactions are also very explosive to be attempted. However, this has been done in more advanced laboratories to obtain the following:

Potassium	↑	Most reactive
Sodium		
Calcium		
Magnesium		
Aluminium		
Carbon		
Zinc		
Iron		
Tin		
Lead		
Hydrogen		
Copper		
Mercury		
Silver		
Gold		Least reactive

### *Using reactivity series in predicting displacement reactions as redox reactions*

A displacement reaction takes place when a more reactive element displaces (removes) a less reactive element in its aqueous solution.

#### **Activity 4.13**

#### *Reacting zinc metal with copper (II) sulphate solution.*

*In groups of four:*

#### *Apparatus and reagents*

Conic flask, white tile, copper (II) sulphate solution, zinc granules, measuring cylinder.

#### *Procedure*

1. Measure 20 cm<sup>3</sup> of copper sulphate solution and place in the conical flask.
2. Place the conical flask on the white tile. Note the colour of the solution.
3. Now, put about 10 g of Zinc granules into the solution. Observe and record what happens.

Account for the results in this experiment.

## The Facts

Zinc dissolves into the solution if copper(II) sulphate displacing copper out of the solution. Copper metal gets deposited as brown solid, while the blue colour of the solution disappears.

The equation of the reaction is:

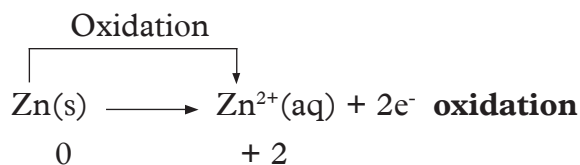


In this reaction, one metal loses its electrons, and another metal gains the lost (donated) electrons. The metal donating the electrons is oxidised, while the metal ions in solution gaining electrons is reduced. Therefore, displacement reaction occurs. The reducing power of the metals decrease down the reactivity series. Metals above in the series displace metals below them from their salt solutions.

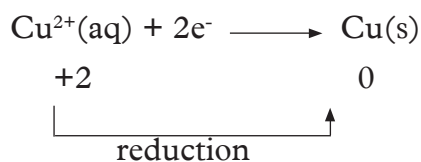
For example:

Calcium	↓	most reactive
Magnesium		
Zinc		
Iron		
Lead		
Copper		least reactive

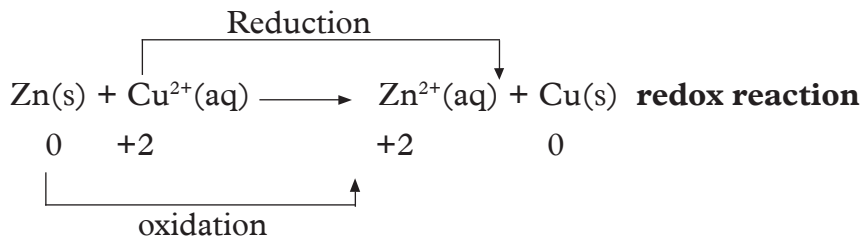
Displacement of copper from copper(II) sulphate solution by zinc is an oxidation reaction.



$\text{Cu}^{2+}$  ions in solution gain the electrons and copper is deposited. In the process, the blue colour disappears. This is a reduction reaction.

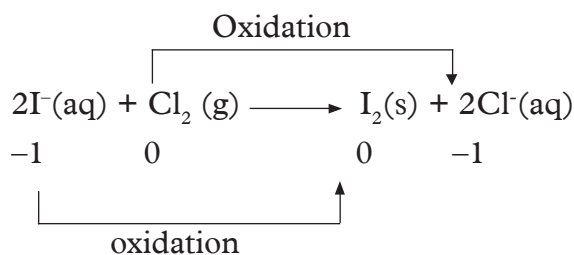
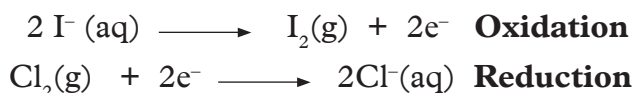


Adding the two half equations we get the overall ionic equation as follows:

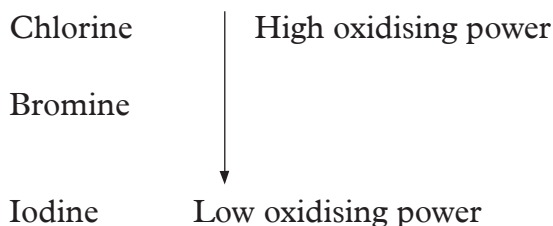


### *Displacement reaction involving halogens*

Halogens also can displace each other from their respective salt solutions according to their reactivity. For example, refer to Activity 4.7. In this activity, chlorine is bubbled through a solution of potassium iodide, iodine is displaced. Iodide ions, I<sup>-</sup> in the solution are oxidised (lose electrons). The electrons are gained by chlorine atoms becoming chloride ions as shown below.



Chlorine is more reactive than bromine. Chlorine can also displace bromine from potassium bromide solution. We therefore say that chlorine is a more powerful oxidising agent than bromine and iodine. The order of oxidising power for some halogens is:



### Check your progress 4.3

1. Describe an experiment you would use to determine the elements that are more reactive
2. Arrange these elements beginning with most reactive to the least reactive  
Mg, Na, Ca, Cu, Zn, K.
3. (a) Write ionic equation for the reaction between chlorine and potassium bromide solution.  
(b) What observations would you make during this reaction?
4. (i) Copy and fill the table below. Put a tick (✓) where a reaction will take place and a cross (x) for no reaction.  
(ii) Write equations where reactions took place.

Metal salt solution	Magnesium	Copper	Zinc
Magnesium sulphate			
Copper (II) sulphate			
Zinc sulphate			

5. Aluminium is above iron in the reactivity series. Write an ionic equation to show how aluminium metal displaces iron from its salt solution.
6. In the following reaction  

$$\text{Cr}_2\text{O}_7(\text{aq}) + 6\text{I}^-(\text{aq}) + 14\text{H}^+(\text{aq}) \longrightarrow 2\text{Cr}^{3+} + 3\text{I}_2(\text{s}) + 7\text{H}_2\text{O}(\text{l})$$
 Name the
  - i. Oxidised element
  - ii. Reduced element
  - iii. Oxidising agent
  - iv. Reducing agent
7. Balance each of the following half-reactions
  - i.  $\text{Fe}^+(\text{aq}) \longrightarrow \text{Fe}(\text{s})$
  - ii.  $\text{Cr}_2(\text{aq}) \longrightarrow \text{Cr}^{3+}$
  - iii.  $\text{O}_2(\text{g}) + 2\text{H}^+(\text{aq}) \longrightarrow \text{H}_2\text{O}_2(\text{aq})$
  - iv.  $\text{Br}_2(\text{l}) \longrightarrow 2\text{Br}(\text{aq})$

## GLOSSARY

### A

**Acetic acid** is also called ethanoic acid and is found in vinegar.

### Acid

- A substance which contains hydrogen which can be displaced by a metal.
- A substance which reacts with a base to form a salt and water only.

### Acid - base reaction

A reaction between an acid and a base to form a salt and water only.

### Acidic oxides

Oxides of non-metal elements. They react with water to form acidic solutions.

### Acid rain

Rain polluted with dissolved gases such as carbon (IV) oxide, sulphur (IV) oxide, oxides of nitrogen and hydrogen chloride produced by industrial activities and natural activities.

### Air

The mixture of gases that surround the earth.

### Alkali

A base that is soluble in water.

### Alloy

A mixture which is made up of two or more metals. Examples brass, bronze, etc.

### Amphoteric oxides

Oxides that react with both acids and alkalis to produce salts.

### Analysis

The investigation or testing of substances to find out what they are or what substances they contain.

### Anaesthetic

A substance that reduces or removes feeling of pain.

### Anhydrous

Containing no water.

An anhydrous substance has no water of crystallisation.

### Antiacids

Substances used to increase the pH of stomach juices and relieve indigestion.

### Apparatus

A set of materials or equipment needed for a purpose or function, e.g an experiment.

### Aqueous solution

A solution where water is the solvent.

### Argon

The most abundant noble gas. It is found in air.

## **Atom**

- The smallest particle of an element that can take part in a chemical reaction.
- The smallest particle into which an element can be divided without losing the properties of the element.

## **B**

### **Balance**

A device for comparing the masses of objects.

### **Base**

A substance that reacts with an **acid** to form a **salt** and **water** only. Bases are usually metal **oxides** and **hydroxides**.

### **Basic oxide**

An oxide that reacts with an **acid** to form a **salt** and water only. Most oxides of metals are basic oxides.

### **Boiling**

The change from the liquid state to the gas state at a particular temperature-boiling point.

### **Boiling point**

The particular temperature at which boiling occurs. Impurities raise boiling point.

### **Brass**

An alloy of copper and zinc.

### **Bronze**

An alloy of copper and tin.

### **Brownian motion**

The random movement of particles suspended in a liquid or gas.

### **Burette**

A long glass tube with a tap or clip at the end. It is usually graduated.

### **Bunsen burner**

A device used for burning natural gas giving a hot flame.

## **C**

### **Calcium**

A metallic element. It is fairly reactive. It reacts with cold water to give hydrogen gas.

### **Carbon**

A non-metallic element, charcoal is a common example of carbon.

### **Catalyst**

A substance which changes the speed of a chemical reaction. It remains unchanged at the end of the reaction.



### **Catalytic convertor**

Part of the exhaust system of modern petrol engines. It reduces the amount of air pollution caused by burning petrol in the engine by converting harmful gases to less non poisonous gases e.g Carbon (II) oxide to carbon (IV) oxide and unburnt hydrocarbon to carbon (IV) oxide and water.

### **Change of state**

Change of matter to and from **solid, liquid and gas**.

### **Charcoal**

A black impure form of carbon.

### **Chemical change**

A change in which one or more new substance(s) are formed. Usually accompanied by giving out or taking in energy.

### **Chemist**

A scientist who has skills in chemistry and performs tests to determine the identity, structure and properties of substances.

### **Chemistry**

The study of nature, structure and composition of substances and the way they behave under different conditions.

### **Chlorination**

The addition of chlorine to drinking water and to water in swimming pools, in order to kill bacteria.

### **Chromatography**

A technique for the separation of a mixture of solutes by the different rates of movement of the solutes through a porous medium like filter paper, under the influence of a moving solvent.

### **Combustion**

A reaction in which a substance combines with oxygen in air. Burning is a combustion reaction which produces a flame.

### **Compound**

A substance formed by the chemical combination of two or more elements in fixed proportions.

### **Condensation**

The process of changing vapour by cooling it into liquid.

### **Conductor**

A solid material which allows flow of electricity through it.

### **Corrosion**

The name given to the process that takes place when metals and alloys are chemically attacked and destroyed by oxygen, water or any other substances found in their immediate environment.

## **Crystallisation**

The process of forming crystals from a saturated solution.

## **D**

### **Decanting**

- The process of removing a liquid from a solid by gently pouring the liquid from one container to another without disturbing the solid.
- Careful pouring to separate an immiscible, heavier liquid from a lighter immiscible liquid.

### **Distillate**

The liquid that results from condensation of a vapour by cooling in distillation process.

### **Distillation**

The process of turning a substance to vapour by boiling then cooling so that it condenses into a liquid in order to separate into the constituents of the substance.

### **Doctor**

A person who is qualified to practise medicine.

### **Drug**

- A substance used in medicine for treatment of diseases.
- A substance that acts on the nervous system, e.g. a narcotic or stimulant, especially one that causes addiction.

### **Downward delivery**

The process of collecting gases which are denser than air.

## **E**

### **Element**

A substance which cannot be further divided by chemical means into simpler substances.

A substance made up of only one type of atoms.

### **Energy of movement**

Energy that an object has because it is moving. It is also called **kinetic energy**.

### **Evaporation**

The process occurring at the surface of a liquid, involving the change of state of a liquid into a vapour or gas.

## **F**

### **Fertiliser**

Natural or artificial material added to soil to make it more fertile and therefore productive.

**Filtrate**

The liquid which passes through the filter paper during filtration.

**Filtration**

A process of separating an undissolved solid from a liquid using a fine filter paper which does not allow the solid to pass through.

**Fractional distillation**

A method of distillation used to separate miscible liquids with different boiling points which are close or less than 40°C using a fractionating column.

**G****Galvanising**

A process of coating an element like iron with zinc to protect it from rust, e.g. in galvanised iron, iron is coated with zinc.

**Gas**

An air-like substance having no fixed shape or volume but able to expand to the shape of its container.

**H****Hydrated substance**

A substance having water of crystallisation, e.g. hydrated copper (II) sulphate which is blue.

**Hydrocarbons**

Compounds which contain carbon and hydrogen only.

**Hydrogen**

A gaseous element; it is the lightest gas.

**I****Immiscible liquids**

Two or more liquids which do not mix but form layers.

**Indicator**

A substance that shows whether a solution is acidic or alkaline. It changes colour when added to acidic or alkaline solutions. For example, litmus and phenolphthalein.

**Insoluble**

A term that describes a substance that does not dissolve in a particular solvent.

**Insulator**

A non-conductor of electricity used to provide protection from electricity.

## L

### **Laboratory**

A room or building where scientific experiments are carried out.

### **Liquid**

Any pure substance that flows freely.

### **Liquid air**

Air that has been made into a liquid by cooling it.

## M

### **Mass**

The amount of matter contained in any substance.

### **Matter**

Anything that occupies space and has mass.

### **Medical laboratory scientist**

A person who performs tests on blood, urine, etc. to determine a person's state of health.

### **Melting**

The process of turning a solid to liquid by heating.

### **Melting point**

The temperature at which a solid turns into a liquid. It has the same value as the freezing point.

### **Metal extraction**

The separation of a metal from its ore.

### **Metals**

A class of elements which have a characteristic shiny appearance and are good conductors of heat and electricity, e.g. calcium, gold, silver, copper, iron, etc.

### **Miscible liquid**

Two or more liquids that mix completely to form homogeneous mixture.

### **Mixture**

A combination of two or more substances that can be separated by physical means. Mixtures can be homogeneous or heterogeneous.

### **Molecule**

The smallest particle of an element or a compound which is normally capable of free and separate existence.

## N

### **Neutral oxide**

The oxides of non-metals which are neither acidic nor basic, e.g. carbon(II) oxide.

**Neutral solution**

A solution which is neither acidic nor basic, e.g. pure water.

**Non-conductor**

A solid which does not allow electricity to pass through it.

**Non-metal**

A class of elements that are typically poor conductors of heat and electricity.

**Nurse**

A person trained to assist a doctor in treating and caring for patients.

**O****Oil refining**

The general process that involves fractional distillation used to separate crude oil into separate fractions.

**Oxidation**

A reaction in which oxygen is added to an element or compound.

**Oxidising agent**

A donor of oxygen.

**P****Pharmacist**

A person with skills in medical drugs.

**pH scale**

A scale running from 1 to 14 for measuring the degree of acidity or alkalinity of a solution.

**Physical change**

A change in which the original properties of a substance are not affected, e.g. heating of wax.

**Pollution**

The addition to the environment of harmful and unpleasant substances by human activities.

**Pure substance**

A substance which has a constant behaviour or properties, e.g. fixed melting point or boiling point.

**R****Reactivity series of metals**

An order of reactivity giving the most reactive metal first. It is based on results from a range of experiments involving metals reacting with oxygen, water, etc.

**Redox reaction**

A reaction involving both reduction and oxidation

**Reduction**

A reaction in which oxygen is removed from a substance.

**Residue**

The solid left behind in the filter paper after filtration or the solid or liquid left in the distillation flask during distillation.

**Rust**

A loose, red-brown, flaky layer of hydrated iron(III) oxide found on the surface of iron.

**Rusting**

The slow oxidation of iron to form rust.

**S****Soluble**

Term that describes a solute that dissolves in a particular solvent.

**Solute**

The substance that dissolves, e.g. sugar dissolves in water.

**Solution**

A substance formed when one substance (solute) dissolves into another.

**Solvent**

The liquid in which a solute dissolves, e.g. water dissolves sugar.

**Stainless steel**

Iron that contains carbon, chromium, nickel and other elements; it does not rust.

**States of matter**

The physical state that matter assumes depending on its nature and also its temperature.

**Sublimation**

The direct change of state from solid to gas or gas to solid without passing through the liquid state.

**Suspension**

Fine particles of an insoluble substance uniformly dispersed throughout a liquid.

**U****Universal indicator**

A mixture of indicators which shows different colours in solutions of different pH.

**Upward delivery**

The method of collecting gases which are less dense than air.

V

**Veterinary officer**

A person with skills in treating diseases and disorders of farm and domestic animals.

W

**Water**

A compound of hydrogen and oxygen.

**Water of crystallisation**

The water chemically combined to the crystals of some substances.

**Word equation**

A summary of chemical reaction using the chemical names of the reactants and products.

## APPENDIX I

Common Names	IUPAC name	Formula
Carbon dioxide	Carbon(IV) oxide	CO <sub>2</sub>
Calcium hydroxide	Calcium hydroxide	Ca(OH) <sub>2</sub>
Calcium oxide	Calcium oxide	CaO
Carbon monoxide	Carbon(II) oxide	CO
Carbonic acid	Trioxocarbonate(IV) acid	H <sub>2</sub> CO <sub>3</sub>
Ferric oxide	Iron(III) oxide	Fe <sub>2</sub> O <sub>3</sub>
Ferrous oxide	Iron(II) oxide	FeO
Hydrochloric acid	Hydrochloric acid	HCl
Hydrogen chloride	Hydrogen chloride	HCl
Lead dioxide	Lead(IV) oxide	PbO <sub>2</sub>
Lead monoxide	Lead(II) oxide	PbO
Magnesium hydroxide	Magnesium hydroxide	Mg(OH) <sub>2</sub>
Magnesium oxide	Magnesium oxide	MgO
Manganese dioxide	Manganese(IV) oxide	MnO <sub>2</sub>
Nitric acid	Trioxonitrate(V) acid	HNO <sub>3</sub>
Nitric oxide (nitrogen monoxide)	Nitrogen(II) oxide	NO
Nitrogen dioxide	Nitrogen(IV) oxide	NO <sub>2</sub>
Nitrous acid	Dioxonitrate(III) acid	HNO <sub>2</sub>
Nitrous oxide (dinitrogen oxide)	Nitrogen(I) oxide	N <sub>2</sub> O
Phosphorus pentachloride	Phosphorus(V) chloride	PCl <sub>5</sub>
Phosphorus trichloride	Phosphorus(III) chloride	PCl <sub>3</sub>
Potassium oxide	Potassium oxide	K <sub>2</sub> O
Sulphur dioxide	Sulphur(IV) oxide	SO <sub>2</sub>
Sulphur trioxide	Sulphur(VI) oxide	SO <sub>3</sub>
Sulphuric acid	Tetraoxosulphate(VI) acid	H <sub>2</sub> SO <sub>4</sub>
Sulphurous acid	Trioxosulphate(IV) acid	H <sub>2</sub> SO <sub>3</sub>
Water	Water	H <sub>2</sub> O
Zinc oxide	Zinc oxide	ZnO



## APPENDIX II

### Safety symbols

#### Warning signs



Electric shock



Oxidising



Flammable



Explosive



Corrosive



Irritant



Toxic



Radioactive



Danger



Laser radiation



South Sudan

# Secondary Chemistry 1

Student's Book

Secondary Chemistry has been written and developed by Ministry of General Education and Instruction, Government of South Sudan in conjunction with Subjects experts. This course book provides a fun and practical approach to the subject of Chemistry, and at the same time imparting lifelong skills to the students.

The book comprehensively covers the Secondary 1 syllabus as developed by Ministry of General Education and Instruction.

**Each year comprises of a Student's Book and Teacher's Guide.**

**The Student's Books provide:**

- Full coverage of the national syllabus.
- A strong grounding in the basics of chemistry.
- Clear presentation and explanation of learning points.
- A wide variety of practice exercises, often showing how chemistry can be applied to real-life situations.
- It provides opportunities for collaboration through group work activities.
- Stimulating illustrations.



All the courses in this secondary series were developed by the Ministry of General Education and Instruction, Republic of South Sudan. The books have been designed to meet the secondary school syllabus, and at the same time equipping the pupils with skills to fit in the modern day global society.

This Book is the Property of the Ministry of General Education and Instruction.

**This Book is not for sale.**

Any book found on sale, either in print or electronic form, will be confiscated and the seller prosecuted.

**Funded by:**



**Published by:**

