

South Sudan

ALP
2

ALP Science

LEVEL 2

©2018, THE REPUBLIC OF SOUTH SUDAN, MINISTRY OF GENERAL EDUCATION AND INSTRUCTION. All rights reserved. No part of this book may be reproduced by any means graphic, electronic, mechanical, photocopying, taping, storage and retrieval system without prior written permission of the Copyright Holder. Pictures, illustrations and links to third party websites are provided in good faith, for information and education purposes only.



This book is the property of the Ministry of General Education and Instruction

THIS BOOK IS NOT FOR SELL

Funded by:



GLOBAL
PARTNERSHIP
for EDUCATION

quality education for all children

FOREWORD

I am delighted to write the foreword for this book. The Ministry of General Education and Instruction (MoGE&I) has developed the Accelerated Learning Programme (ALP) textbooks based on the National Curriculum of South Sudan.

The textbook was written to help learners develop the background knowledge and understanding in the subject. It is intended largely to serve as a source of knowledge and understanding of the subject concerned, but not to be considered as a summary of what learners ought to study.

The National Curriculum is a competency based and learner-centered that aims to meet the educational needs and aspirations of the people of South Sudan. Its aims are manifold: (a) Good citizenship (b) successful lifelong learners, (c) creative, active and productive individuals; and (d) Environmentally responsible members of our society.

This textbook was designed by subject panelists to promote the learners' attainment of the following competencies; critical and creative thinking, communication, cooperation, culture and identity.

No one can write a book of this kind without support from colleagues, friends and family. Therefore, I am pleased to register my thanks to Dr Kuyok Abol Kuyok, the Undersecretary of the Ministry, who emphasized the importance of Alternative Education System (AES) and approved the development of its textbooks.

I also want to record my thanks to Ustaz Omot Okony Olok, the Director General for Curriculum Development Centre (CDC) and Ustaz Shadrack Chol Stephen, the Director General for Alternative Education Systems (AES) who worked tirelessly with the subject panelists to develop the textbooks.

Lastly, but not least, my greatest thanks and appreciation must go to the Global Partnership for Education (GPE) and UNICEF-South Sudan for without their support and partnership this textbook would not have seen light.



Hon. Awut Deng Acuil, MP
Minister,
Ministry of General Education and Instruction
Republic of South Sudan, Juba



Contents

UNIT 1: Health habits.....	1
Importance of food to our bodies.....	1
Foods we eat in the locality.....	3
Deficiency (lack) of food.....	12
Importance of washing dirty clothes	15
Types of soaps and detergents	19
UNIT 2: Caring for our environment.....	22
2.2 Safety and hygiene when cleaning.....	23
2.1 Importance of cleaning our surroundings.....	22
UNIT 3: Plants and animals	27
Habitats of different plants and animals.....	29
Characteristics of plants and animals found on land.....	35
Fruits and seeds.....	40
UNIT 4: Seeds and germination.....	43
Parts of a seed.....	44
a) Parts of a bean seed.....	45
b) Parts of a maize seed.....	46
3.2 Germination of seeds.....	50
Conditions necessary for seed germination.....	52
UNIT 5: Using our senses.....	57
The five senses.....	57



Sense of hearing.....	58
Sense of taste.....	59
Sense of smell.....	60
Sense of touch or feeling.....	61
Echoes.....	67

UNIT 6: Grouping plants and animals, their conservation and food chain

.....	68
-------	----

Herbivore.....	69
Carnivores.....	72
Birds.....	75
Insects.....	78

UNIT 7: Weather and wind.....92

Weather changes.....	92.
Air pressure.....	96

UNIT 8: Matter and materials.....109

Sources of light	124
Heat energy.....	136

UNIT 8: Light and heat.....124

UNIT 9: Electricity and Magnetism.....145

Current electricity.....	147
Static electricity.....	145
Magnetism.....	158



Words to learn

Energy, exercise, deficiency, detergent,
soap, nutrient

Importance of food to our bodies

Before you came to school, you ate some food. Can you tell your friend the food that you ate? Do you eat the same food every day?



Let us talk

Look at the pictures below.

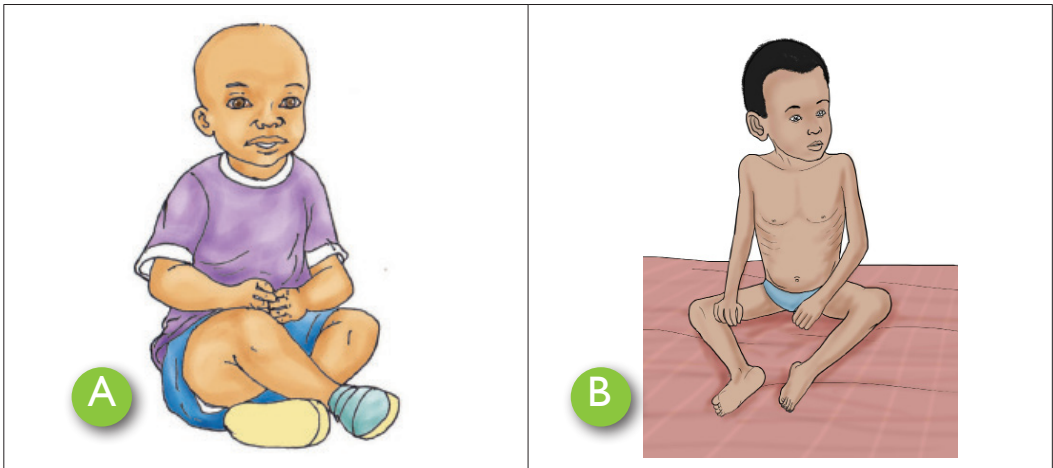

Which of the two children is healthy? Which one is unhealthy?
What should the parents of unhealthy child do?

Learning point

Our bodies need food. Food gives us the energy to grow and develop, to be healthy and active, to move, to work, to play, to think and to learn. The food that we eat in the morning is breakfast. The food we eat at noon is lunch and the food we eat in the evening is supper.



Check your progress I (a)

1. When we eat food we become _____. (healthy, unhealthy)
2. You are provided with the food below.

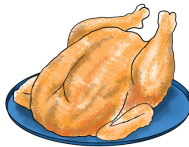

Come up with menu for a healthy day.



Foods we eat in the locality



Activity 1

Work in groups of four



What to do







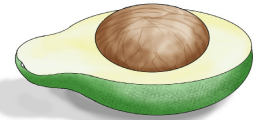

1. Use the chart provided by your teacher to group food items according to colour, taste and smell.
2. Draw and colour food items found in the chart.
3. Use the chart to fill the table below. Draw the table in your exercise book.

Food eaten locally	Food grown locally
	

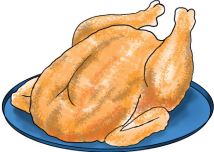
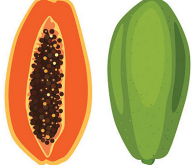
Learning point

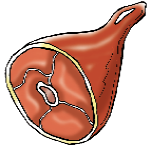

Some of the foods that we eat from our locality are:

 <p>Avocado</p>	 <p>Bananas</p>	 <p>Tomatoes</p>
 <p>Chicken</p>	 <p>Pawpaw</p>	 <p>Eggs</p>
 <p>Cabbage</p>	 <p>Cassava</p>	 <p>Glass of milk</p>
 <p>Peas</p>	 <p>Beans</p>	 <p>Meat</p>

Local foods

My health my life

You should avoid eating take away foods such as chips, chicken and bugger. They can cause diseases like obesity.



Check your progress I (b)

1. Name and describe features of the foods drawn.

a) _____

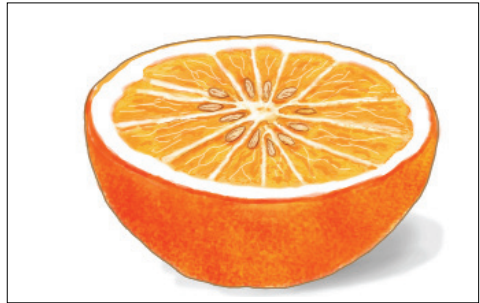

b) _____

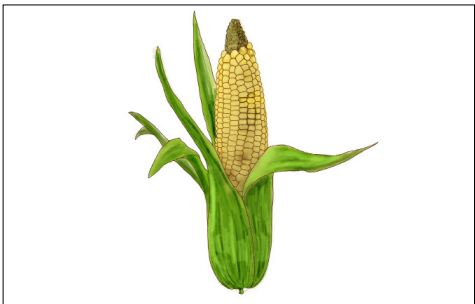

c) _____



d) _____

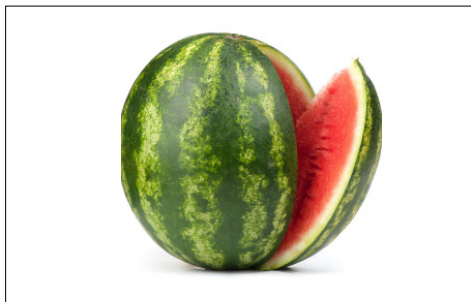

e) _____

Foods for body building and growth (Grow foods)



Activity 2

As a class









What to do

1. Collect a variety of foods.
2. Observe the foods.
3. Use the chart provided by your teacher to identify body-building foods.
4. Draw and colour the foods.

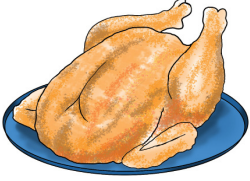
Learning point

Body building foods help us to **grow** and stay **healthy**. We are able to move, run, and exercise when we eat body building food. We get body building foods from a variety of animals and plant based foods. Examples of body building foods are:

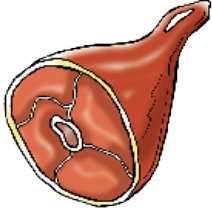

 <p>Chicken</p>	 <p>Eggs</p>	 <p>Lentils</p>
 <p>Beans</p>	 <p>Meat</p>	 <p>Glass of milk</p>
 <p>Fish</p>		

Body building foods



Check your progress I (c)

1. Draw and name two body building foods from animals.
2. Draw and name two body building foods from plants.

Foods for energy in movement, work and exercise (Go foods)

In our lives, we do many things.



Let us talk

Look at the pictures below.



A

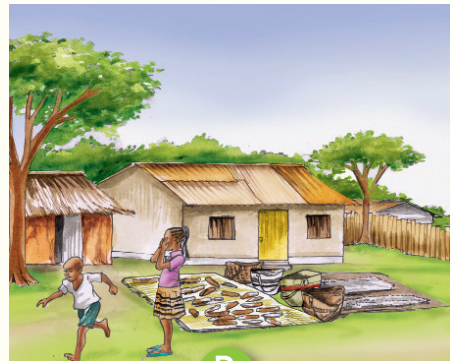

B



C



D









Can you give other activities that we do at school and at home?

Role play different activities that you do at home and at school.

Learning point

The pictures above show some activities that we do in our lives. We work, play and study at home or at school.

We can work, play and study when we eat food that provide bodies with energy. When you do not eat enough energy containing foods, you will feel very tired when playing or working.

 Maize	 Posho	 Irish potatoes
 Cassava	 Sugarcane	 Rice
 Bread	 Yams	 Sweet potatoes

Energy giving foods



Check your progress I (d)

1. Draw and colour three foods that give us energy.
2. Name three activities that you do at school.
3. Name three activities that you do at home.

Importance of exercises to our bodies



Activity 3

Work in groups of four



What to do

1. Your teacher will put you into different groups to play a game of your choice.
2. Play with your friends in the group.
 - How did you feel after playing?
 - What should you do after playing?

Learning point

Exercise is important to our bodies. Exercises help all the parts of the body. The exercises should not be difficult or too long for us. Exercises make us do our work well. They make our bodies stronger.

We regularly exercise by playing games. Some games that we play at school and at home are given below.

Remember! Exercise daily to remain physically fit.

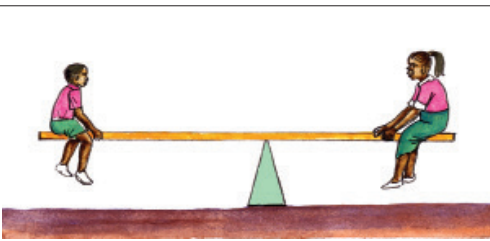

Balancing on a seesaw



Skipping



Playing football



Dancing

Remember! We should have enough rest after exercising.

My health my life

You should exercise daily to be physically fit!



Check your progress I (e)

1. Write true or false
 - a. Exercises should be difficult.
 - b. We should exercise more often.
 - c. Exercising make us become physically fit.
 - d. Sleeping is an exercise.
2. Write two exercises that you like doing either at home or school.

Deficiency (lack) of food



Let us talk

Look at the two pictures below. What can you see?

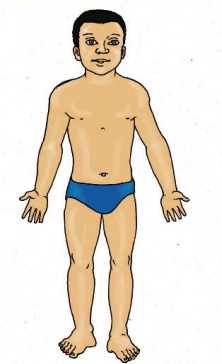

A



B



Activity 4

Work in pairs



Recite the poem below

To stay healthy we should always eat good food.
You need apples, you need peas!
You need bananas and green beans!
You need lots of fruits and vegetables in your diet.

You need cereals, bread, rice and porridge!

They are all energy-giving foods!

You need food to make your body grow!

You need fish, meat and eggs!

Yes you need body-building foods to make you grow.

Answer the questions below

1. What did you learn from the poem?
2. Compose a similar poem replacing the foods described above with your favourite food.
3. Use the poem to fill the table below in your exercise book.

Healthy food	Tasty food

Learning point

All foods are important to the body. Lack of any of them may result in **diseases**. Eating all food helps us to keep our bodies healthy. A healthy person is not **sick**, able to **work**, is **strong** and is **happy**.



Check your progress I (f)

1. Fruits and vegetables come from _____
2. Write if it is a fruit or a vegetable



a) _____

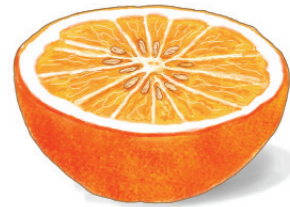

b) _____



c) _____

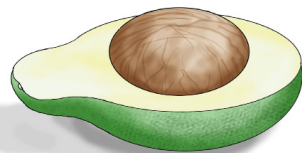

d) _____

Advice !

We should drink at least eight glasses of water everyday!.



Importance of washing dirty clothes



Let us talk

Look at the pictures below. What do you see?

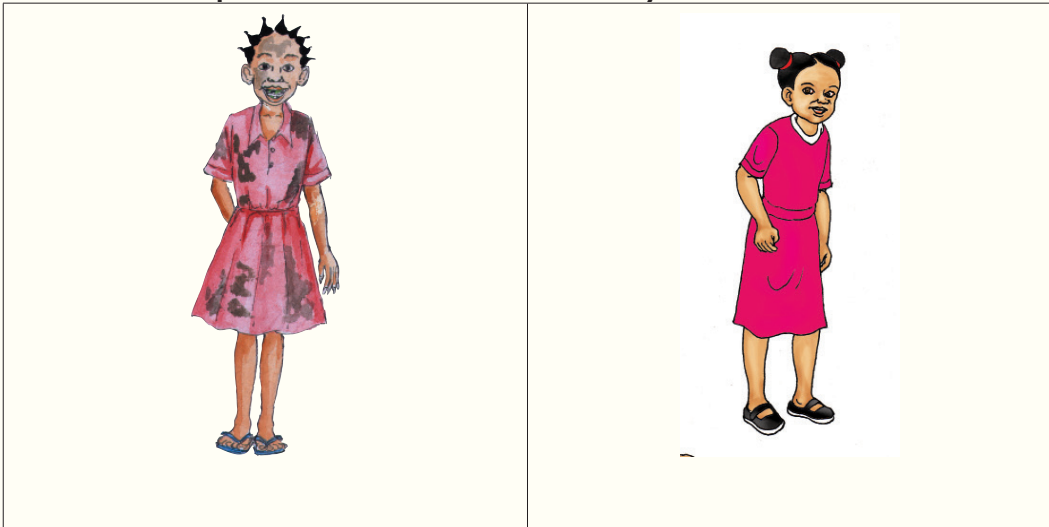

A

B

What should the girl in picture **A** do?

Learning point

The girl in picture A is putting on dirty clothes and sandals. The girl in picture B is putting on clean clothes and shoes. We should always put on clean clothes and clean shoes. When we put on clean clothes we look smart and neat. Dirty clothes smell bad. Dirty clothes can also make us sick. After wearing clothes we should wash them.

What do we need when washing clothes? What should we do when washing clothes?





Activity 5

Cleaning school uniform

As a class



What you need

Clean water, soap, basin and pegs



What to do

1. Soak your school uniform in soapy water.
2. Using your hands, rub the school uniform to remove dirt.



4. Hang them out on a clotheline using pegs to dry.



Learning point

Clothes become clean when they are washed. Clean clothes are free from germs that cause diseases. Clean clothes last longer and smell good. When we wear clean clothes, we look neat and smart.

Did you know!

If we put on clean clothes, we protect ourselves from diseases.



Check your progress 1 (g)

1. Dirty clothes smell _____ (good, bad)
2. Name three items we use when washing clothes.
3. We wash clothes to remove _____

Types of soaps and detergents



Let us talk

Look at the pictures below. What do you see? Do you know what are the things in the pictures?

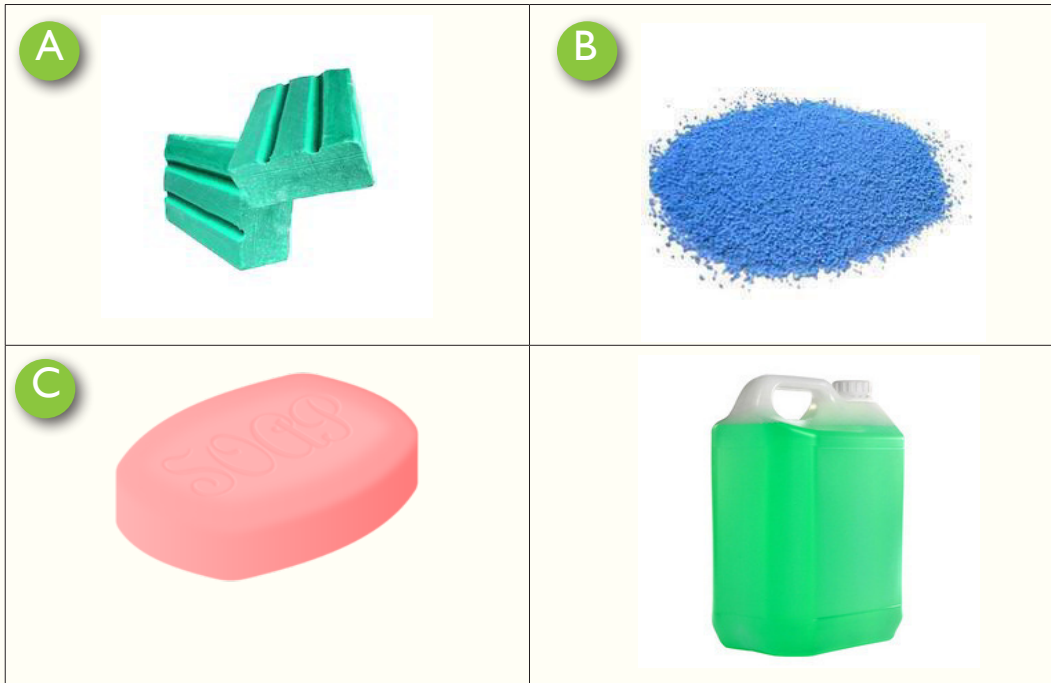

Learning point

Picture **A** shows a bar soap, picture **B** shows powder soap, picture **C** shows a bathing soap and picture **D** shows a liquid soap. Picture **A** and Picture **B** are used in washing clothes; they can also be used in washing utensils. Washing dirty clothes requires adequate clean water, detergents (solid or powdered soap) and washing materials.



Activity 6

1. Write a list of activities that makes you tired. Share what you have written with your friend.

Learning point

Some of the tiring activities include:



Playing



Walking for a long distance



Running



Cleaning



Check your progress I (i)

1. When we get tired, we _____.
2. Resting makes our bodies to _____. (feel pain, relax)
3. Name the various ways in which we rest.
4. When we get enough sleep, we are _____ in class. (active, inactive)
5. Copy and complete the table below in your exercise book.

Most tiring activities	Least tiring activities

2.1 Importance of cleaning our surroundings

Activity 1

In pairs

What to do

Look at the pictures below.



A

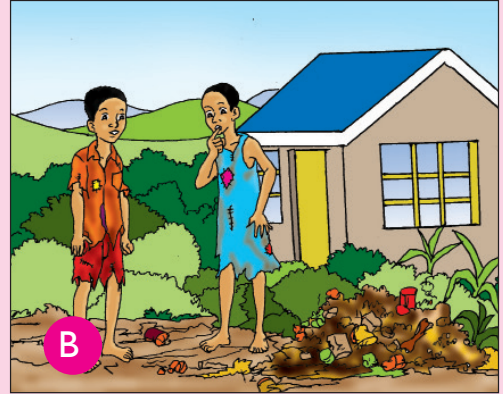

B

1. Find out the meaning of the word environment.
2. Which environment would you like to live in? Why?
3. Why is it important to live and work in a clean environment?

Learning points

- The word environment means our surroundings. It is important that we clean our environment or surroundings.
- A clean environment is safe and healthy to live and work in.
- A dirty environment is unsafe and unhealthy to live in. We can get diseases or get injured in a dirty environment.

Check your progress 1.1

1. Why should we live in a clean environment?
2. Mention any four types of waste or rubbish you will find in a dirty environment.
3. What harm can a dirty environment cause?

2.2 Safety and hygiene when cleaning



A



B

Activity 2

 In pairs

What to do

Study the two pictures below.

1. Tell your friend what these two people are doing.
2. Which picture shows a person who is properly dressed for the work?
3. What are the effects of working in unsafe conditions?
4. Name some of the things the person in picture A is wearing and why they are important.
5. What is likely to happen to the person in picture B.

Learning points

It is important to wear protective clothing when we are cleaning. The following are some of them.

- Overalls – Protect our clothes from getting wet or stained or dirty.

- Gumboots – Protect our feet from injuries, for example, getting cut by broken bottles or sharp stones.
- Dust mask – Stops dust particles and bad smells from entering our nostrils.
- Goggles – Protect our eyes from injuries caused by dust particles and soaps.

1. When cleaning what should we wear to protect our:
 Feet? _____
 Hands? _____
 Eyes? _____
2. Match the following safety clothing with their work.

Safety gear	Function
	Protects our eyes from injury.
	Protect our clothes from getting dirty or stained.
	Stops dust particles and bad smell from entering our nostrils.



Protect our feet from injury.

Remember!

Always wear protective clothing when cleaning.

1.5 Proper disposal of different types of waste

 In groups

What to do

1. Collect rubbish from your school.
2. Bring all the rubbish to an open space and sort them into three groups.
 - Which rubbish can be used again?
 - Which rubbish can be used to make new products?
 - Which rubbish will rot and which will not rot?
3. Dig pits in the ground. Bury some of the rubbish in the pits. After a few days, dig up the rubbish. Which ones are rotten and which ones are not?
4. Use your observation to fill them into a table like the one drawn below.

Can rot	Cannot rot	Can be used again

5. Discuss the methods you can use to best dispose off each type of rubbish.
6. List down the disposal methods. Discuss which methods are safe and which ones are not safe and why?

7. Look at your school compound after this activity. Describe how it looks.

Learning points

The two main groups of wastes are biodegradable and non-biodegradable wastes.

- a) Biodegradable wastes – These are wastes which can rot or be decomposed by natural methods. They include kitchen garbage animal dung and vegetable remains, among others.
- b) Non-biodegradable wastes – These are wastes that cannot be decomposed. They remain in the environment for a long period of time. Examples include plastics, polythene bags, glass and rubber, among others.

Note: Some of the non-biodegradable wastes can be re-used, reduced or recycled.

Make flash cards and use them to label the dustbins in your school. This is to help your schoolmates separate garbage into biodegradable and non-biodegrade wastes.

Check your progress 1.5

1. The two main categories of wastes are _____ and _____.
2. _____ waste cannot rot by natural methods.
3. A teacher wrote the following list on the chalkboard as examples of wastes: glass, rotten cabbage, plastic bottle, nails, rotten mangoes, stale bread, spoilt onions and broken plastic plate. Put them in two lists of biodegradable and non-biodegradable wastes?
4. When biodegradable wastes decomposes, they turn into _____.
5. _____ waste materials can be used again.



Words to learn

Environment, plant, land, habitat,
farm, seed, fruit,



Let us talk

Look around you. What can you see? Name them.

Learning point

When we look around us we see plants, animals, water bodies such as lakes and other things such as buildings. Common plants and animals that are found around us include:

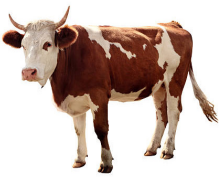









Cow



Maize plant



Grasshopper

 <p>Cat</p>	 <p>Dog</p>	 <p>Mango plant</p>
 <p>Butter fly</p>	 <p>Coconut plant</p>	 <p>Bee</p>
 <p>Bull</p>	 <p>Bean plant</p>	 <p>Tsetse fly</p>

Name other plants and animals around you that are not listed above.



Check your progress 3(a)

1. Draw and name at least three animals and three plants you can see around you.
2. Using a table, list living and non-living things in your area.

Habitats of different plants and animals



Let us talk

Look at the pictures below. Name the things you can see?

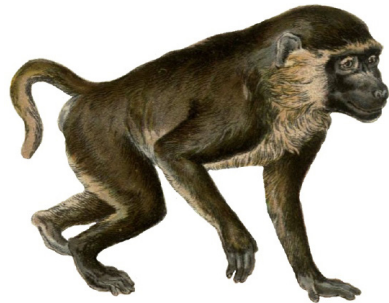
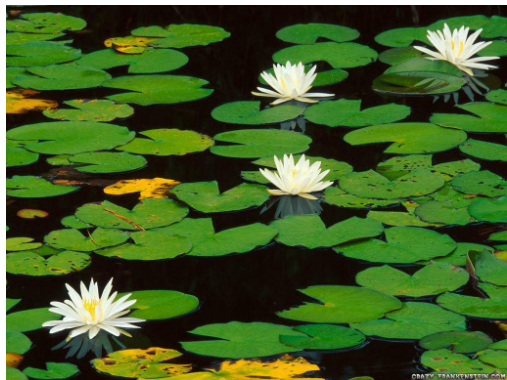



Fish



Water hyacinth



Lobster



Seaweed



Octopus



Lotus

Learning point

Different animals and plants live in different places

Examples of places where animals and plants live are

a. Water

Some water living organisms live in water.

Water environments where plants and animals live are rivers, oceans, dams, lakes, ponds and swamps.



Check Activity

1. Check activity 1 on page 29 can you remember the plants and animals that you saw.
2. Write down some of the observable features of the plants and animals.

Learning point

Plants that live in water have large and broad leaves.

Most of them have many leaves and floating flowers.

Animals that live in water have fins, gills and they are able to swim.



Check your progress 3(b)

1. Write two characteristics of plants that live in water.
2. Draw and name a plant that lives in water.
3. List observable features of animals that live in water.
4. Draw and name two animal that lives in water.

b. Land

We live on land. Land is made up of soil. We step on soil as we go to school. Depending on the location of the land, where we stay, land has different characteristics.



Activity I

As a class



What to do

1. Go outside class and observe the plants and animals in their environment.
2. Back in class, group them as plants and animals found in gardens, farms, forests and bushes.
3. Draw and name plants found in different habitats.

Learning point

Some of the plants and animals found on land include:

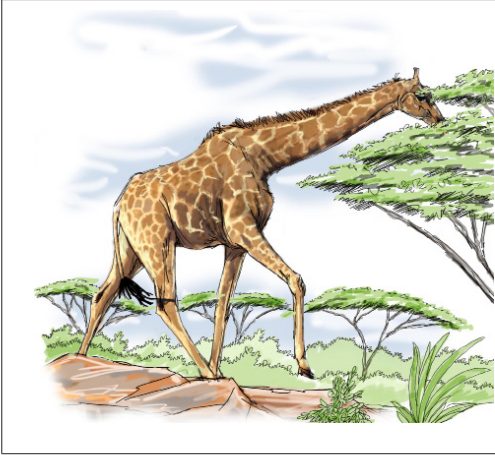

Maize plant



Beans plant



Sunflower plant



Coconut tree



Cactus



Mango



Lion



Gazelle



Zebra



Cheetah

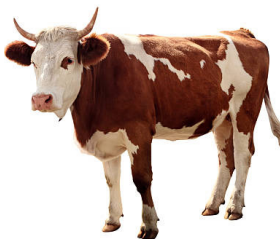

Cow



Goat

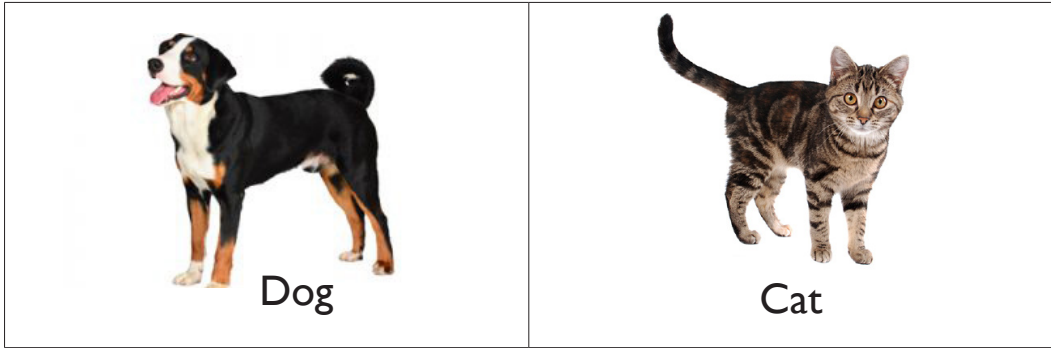

Name other animals that are found on land that are not listed in the above pictures.

Characteristics of plants and animals found on land

Some animals that live on land have long necks to enable them to eat. Example is giraffe.



Giraffe

Others have Long legs enabling them to run while others have fur to keep them warm.



Baboons with fur on their body

Some of the animals such as lion has strong and sharp claws that catch and tear flesh from prey.

Activity 2

1. Go for natural walk.
2. Observe plants and animals around you.
 - What is common with plants around you?
 - What about animals around you?



Learning point

(i) Plants

- Have long roots because of need for water.
- Some plants have big leaves, others have small leaves.
- Some plants have very few leaves, some have many.
- Some plants have thick stems that are soft. Others have hard stems.

(ii) Animals

Some have long necks to enable them reach leaves high up on tree.



Check your progress 3t(c)

1. Hippopotomus, baboon, lion, seaweed, fish, camel, water lily, whale, octopus, dog, goat, and lotus.
 - (a) Use the table to group the above as either a plant that live on land or water.
 - (b) Copy and fill the table below.

Animal that live on land	Animal that do not live on land

(iii) Forest

Activity 3

As a class



With the guidance of your teacher, visit a forest and identify plants and animals that live there. Draw and colour them in your exercise books.

Learning point

In the forest, there are many types of plants. Many animals also live in the forest. Some of the plants that are found in the forest are:



Oak



Liverworts



Cactus



Eucalyptus



Lichens on a tree



Mosses

Name other plants that are found in the forest that are not in the listed pictures.

On the other hand animal that are found in the forest are:

Name other animals found in the forest that are not in the pictures above.



Check your progress 3(d)

1. Draw two trees that grow in the forests.
2. Draw two wild animals that you know.

My environment my life

We should avoid polluting our land and water.

Fruits and seeds

Activity 4

1. Collect a variety of seeds and fruits.
2. With the guidance of your teacher, group fruits in one column and seeds together. Use a table like this.

Fruit	Seed





3. Draw and colour the fruits and seeds in your exercise book.

Learning point



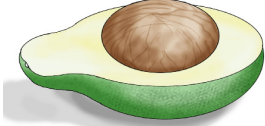

We have a variety of fruits and seeds. They include:

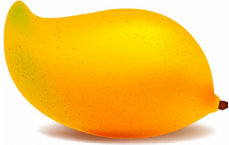

Common fruits

 <p>Orange</p>	 <p>Tomatoes</p>	 <p>Avocado</p>
 <p>Pineapple</p>	 <p>Mango</p>	

Common seeds

 <p>Beans</p>	 <p>Maize</p>	 <p>Groundnuts</p>
 <p>Millets</p>	 <p>Cashewnuts</p>	



Check your progress 3(d)

1. Young plants grow from -----.
2. A mango fruit has _____ seeds.
3. Draw, name and colour 3 fruits.
4. Identify the seeds below.



a) -----



b) -----

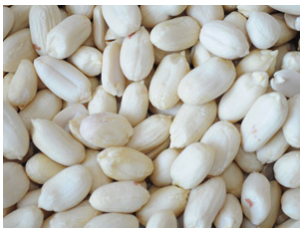

c) -----



d) -----

Activity 4.1

 As a class

Materials

- Different kinds of fruits
- Sharp knife or razor blade
- Magnifying glass

What to do

1. Collect as many fruits as possible and bring them to the classroom.
2. Take one fruit at a time and carefully cut it open.

Warning!

Be careful when using sharp knives or razor blades. Knives and razor blades with fresh blood can transmit HIV.

3. Observe what you see inside each fruit. What do you see?
4. Count the number of seeds inside each fruit and record the number.

Remember!

Not all fruits can be eaten. Some fruits are poisonous

Learning points

- All flowering plants produce fruits. Fruits contain the seeds of the plants inside them.
- The fruit of each plant has a different size and shape from that of another plant. We eat many fruits.
- Some fruits have only one seed while others have many seeds. For example, a mango fruit has only one seed. However, an orange fruit has many seeds.

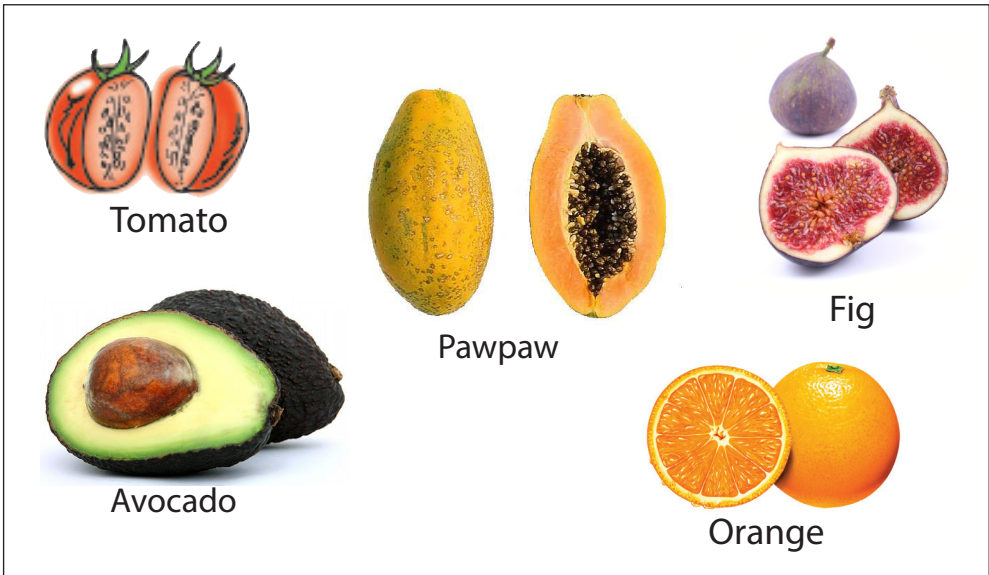

- Different fruits produce seeds of different sizes and colours.
- Some of these seeds can also be eaten as food.

Remember!

Not all fruits can be eaten. Some fruits are poisonous

Parts of a seed

Examining maize and bean seeds

Activity 4.2

 In groups

Materials

- Maize and bean seeds
- Sharp and clean razor blade
- Magnifying glass

What to do

1. Soak maize and bean seeds overnight in water.
2. Observe each seed by using a magnifying glass. What do you see?
3. Open up each seed by cutting it using a razor blade.

4. Observe the inside of each seed. What do you see?
5. Draw and label the parts of the seeds.

Learning points

Seeds are made up of different parts as shown below.

a) Parts of a bean seed

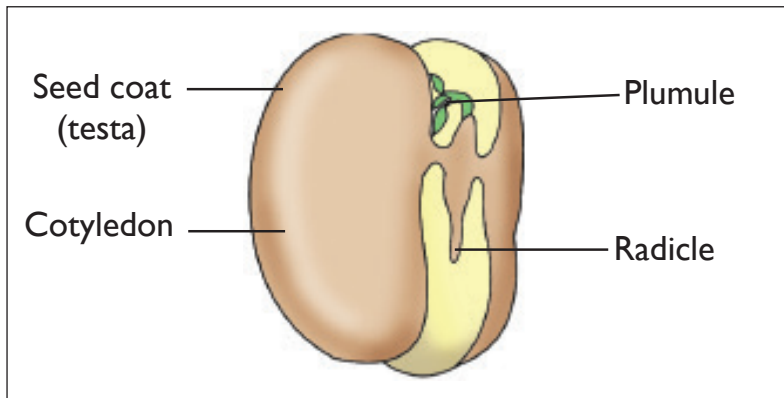

External parts of a bean seed

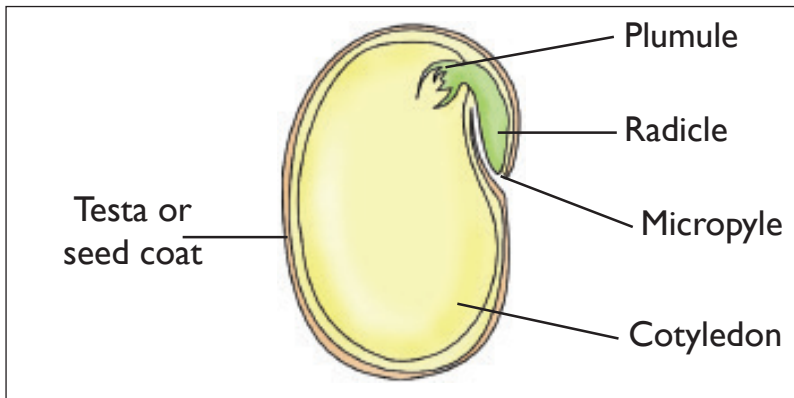

Internal parts of a bean seed

Note: A bean seed has two cotyledons (seed leaves). Therefore, it is called a dicotyledon. Examples of dicotyledons are beans and peas.

b) Parts of a maize seed

Like a bean seed, a maize seed also has internal and external parts.

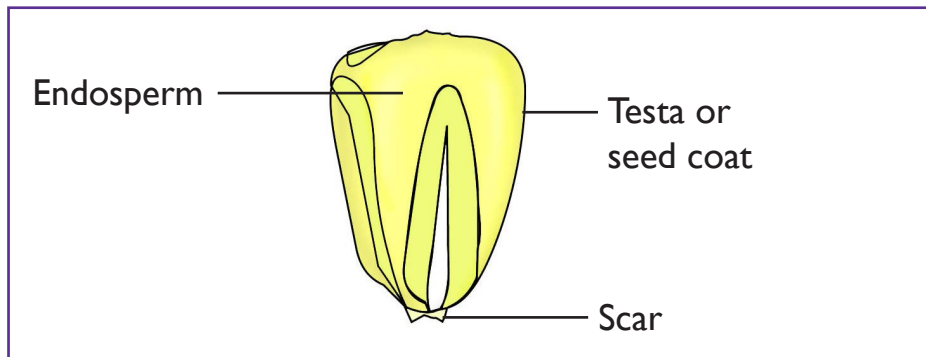

External parts of a maize seed

Internal parts of a maize seed

Note: The maize seed has only one cotyledon.

The parts above serve different functions as follows:

- Testa or seed coat – Protects the inner parts of the seed.
- Micropyle – It is the small pore or opening in the seed coat of a seed. It allows water and air into the seed. It also allows the radicle to come out during germination.
- Scar – This is the point on a bean seed where it was attached to the pod.
- Embryo – It is the living part of the seed. It is made up of the plumule and the radicle. Plumule grows to form the shoot while radicle grows to form the roots.
- Cotyledon – Stores food for the developing seedling during germination.

Remember!

Plumule and radicle together are called the embryo. This is because the two grow into the new plant (seedling).



Check your progress 3.1

1. Write True or False.
 - a) All fruits can be eaten.
 - b) All plants produce fruits.
 - c) We should always wash fruits before we eat them.
 - d) All seeds are the same size.

The diagram below shows the parts of a bean seed. Use it to answer questions 2, 3 and 4.

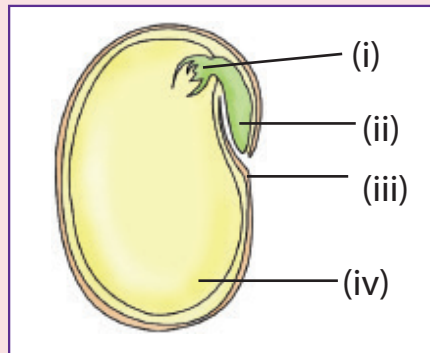

2. Which part represents the seed leaf?
3. The seed drawn above stores food in the part marked _____
4. The part of the seed above that was originally attached to a pod is called a _____

Activity 3.3

 In groups

Materials

- Maize and bean seed
- Sharp clean razor blade
- Magnifying glass

Activity 4.3

 In groups

Materials

- Maize and bean seed
- Sharp clean razor blade
- Magnifying glass

What to do

1. Soak maize and bean seeds for a day or two.
2. Observe each seed using a magnifying glass.
3. Open up each seed by cutting using a razor blade.
4. Observe the inside of each seed.
5. Discuss and write down the differences you can observe between a maize and a bean seed.

Learning points

- The bean seed has two cotyledons. The maize seed contains only one cotyledon.
- Plants that produce seeds with two cotyledons are called dicotyledons or dicots. Example of dicotyledons are beans, groundnuts and peas.
- Plants that produce seeds with one cotyledon are called monocotyledons or monocots. Examples of monocotyledons are maize, rice, wheat, barley and millet.

Differences between monocotyledons and dicotyledons.

Activity 4.4

 In pairs

Materials

- An uprooted maize seedling or grass
- An uprooted bean seedling or groundnut
- A magnifying glass.





What to do

1. Using a magnifying glass, observe the roots and the leaves of each plant.
2. Draw the leaf of each plant and write down the difference between the two leaves.
3. Draw the roots of each plant and write down the differences between the two roots.

Learning points

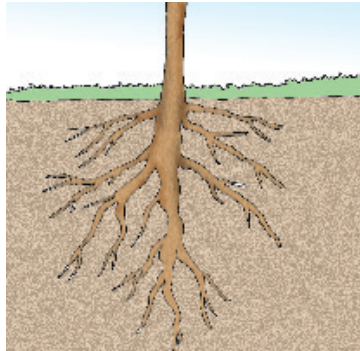
Some of the differences between monocotyledons and dicotyledons:

Monocotyledons (monocots)	Dicotyledons (dicots)
The seeds have one cotyledon	The seeds have two cotyledons
The plants have a fibrous root system. 	The plants have a tap root system. 
Leaves have parallel veins. 	Leaves have network veins. 
Seeds store food in endosperms.	Seeds store food in cotyledons.

Mainly made up of cereals such as maize, sorghum, wheat, oats and barley.

Mainly made up of legumes such as beans, cowpeas, groundnuts and cashew nuts.

Check your progress 3.2

Use the picture below to answer questions 1 to 3.



1. The seeds are obtained from a _____ plant.
2. In which part do the seeds above store food?
3. Which type of roots are found in the plant the seeds are shown in the picture?
4. Draw a leaf from a monocotyledon plant.
5. Draw and label a seed from a dicotyledon plant.

3.2 Germination of seeds

Observing germination and growth in maize and bean seeds

Activity 4.5

 In groups

Materials

- Maize and bean seeds
- Glass jars, tins, boxes or plastic containers



- Cotton wool or soil or tissue paper
- Water
- Magnifying glass

What to do

1. Mark the two tins as jars A and B. Put cotton wool or soil or tissue paper in each jar or tin or plastic container.
2. Place maize seeds in jar or tin A.
3. Place bean seeds in jar or tin B.
4. Add a little water in each jar or tin to make the cotton wool or soil wet but not soggy. Keep the cotton wool or soil wet for 14 days.



5. Observe what happens in each tin or jar for 14 days. Draw the seeds in each tin or jar after 3 days, 5 days, 10 days and 14 days.
 - Which parts of the germinating seeds appear first?
 - Do they have the same structures?
 - Do they have the same number of leaves?
 - Do they have the same roots?
 - Which seeds have cotyledon above the cotton wool or soil?
 - Which seeds have cotyledons below the cotton wool or soil?

Learning points

- When you plant seeds in wet soil, they absorb water and swell up. Later, they grow into little plants called seedlings.
- The growth of seeds to form little plants or seedlings is called germination.
- For the process of germination to take place, the following must be present:
 - i) Air (oxygen)
 - ii) Water (moisture)
 - iii) Suitable temperature (warmth)

Conditions necessary for seed germination

Investigating water as a condition necessary for germination

Activity 4.6

 In groups

Materials

- Bean seeds
- Cotton wool
- Two identical glass jars
- Water

What to do

1. Label two glass Jars A and B.
2. Put dry cotton wool in Jar A and wet cotton wool in Jar B.
3. Put the same amount of bean seeds in each glass jar.
4. Observe for four to five days for any changes. Write them down.

Investigating oxygen as a condition necessary for germination

Activity 4.7

 In groups

Materials

- Bean seeds
- Boiled water
- Two glass jars
- Oil
- Tap water
- Cotton wool or tissue paper



What to do

1. Set up the experiment as shown in the following diagram.

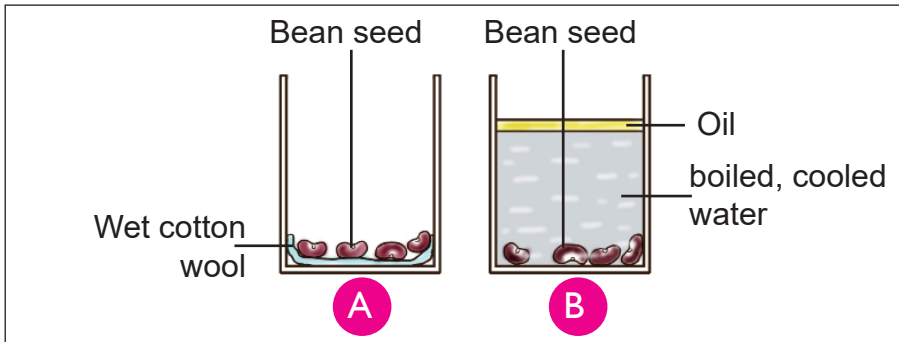

2. Put wet tissue or cotton wool in Jar A.
3. Put an equal number of bean seeds in the two jars labelled A and B.
4. Add boiled cooled water in Jar B. Then add a little oil onto the water.
5. Place Jars A and B safely in the classroom for five days. Do not move them during the five days.
6. Observe what happens to the seeds in each jar.

Investigating warmth as a condition necessary for germination

Activity 4.8

 In groups

Materials

- Bean seeds
- Cotton wool
- Refrigerator
- Ice cubes
- Water
- Two identical glass jars

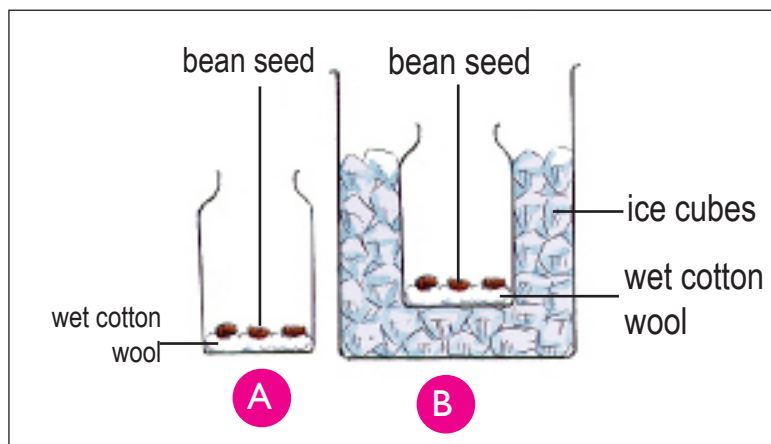

What to do

1. Put cotton wool in two glass jars, A and B.
2. Plant an equal number of bean seeds in the cotton wool in the two jars.
3. Add an equal amount on water on the cotton wool in the two jars.
4. Place Jar A safely in your classroom.
5. Place Jar B safely in a refrigerator or add some ice cubes into the jar.
6. Leave both jars where you have put them for five days.
7. Observe what happens to the seeds in the jars during this period.

Remember!

We can measure temperature using a thermometer.

Learning point

Germination will occur in the seeds placed in the classroom. However, germination will not take place in the jar with ice cubes or placed in the refrigerator. This is because the temperatures are too low. Temperatures that are too cold or too hot do not favour germination.

Investigating light as a condition necessary for germination

Activity 4.9

 In pairs

Materials

- Bean seeds
- Soil
- Box or cupboard or carton
- Glass jars or tins
- Water

What to do

1. Put soil in two tins, A and B.



- Plant an equal number of bean seeds in the soil in the two tins.
- Add an equal amount of water to the soil in the tins.
- Place Tin A safely in your classroom.

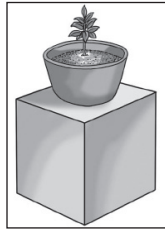

- Place Tin B in a dark cupboard and close it or cover it with a box on which you have made a small hole on one of the sides.

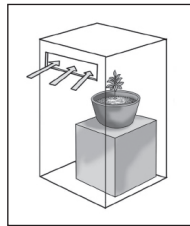

- Leave both tins where you have put them for 7 days.
After 7 days, open the cupboard or uncover tin B by removing the box or carton.
- Observe the stems and leaves of the seedlings in both Tins A and B.
 - Do you notice any difference?
 - What do you think has caused the stems to grow differently?

Learning point

When seeds germinate with the right conditions, the seedling grows with the stems straight up in the direction of sunlight. This is what happened to the seedlings in Tin A which was placed in the classroom.



Healthy seedling growing under direct sunlight

On the other hand, the seedlings in Tin B will germinate. However, they will grow with stems bending in the direction of the hole you made in the carton or box. This shows that the seeds will grow towards the direction of light.

Check your progress 4.3

1. What conditions are required for seeds to germinate?
2. Write True or False.
 - a) Seedlings can germinate anywhere?
 - b) Light is necessary for germination?
 - c) Air is necessary for germination?
 - d) Soil is necessary for germination?
 - e) The radicle is the first to grow during germination?

Words to learn

Senses, organs

The five senses



Let us talk

What are sense organs? How many are they? Can you draw all the sense organs?.

Learning point

The eye, ear, nose, tongue and skin are **sense organs**. Different sense organs helps in detecting different things around us:

- We use our eyes to see.
- We use our nose to smell.
- We use our skin to touch and feel things.
- We use our ears to hear.
- We use our tongue to taste.

Sense of hearing



Activity 3

Work in groups of three



What you need

- A bell, a piece of clean cloth, flute, whistle and drum

Learning point

The ears are our organs of hearing.



Ear

Ears are found on the head. Whatever the ear hears is known as sound. **Sound** is produced by different objects. When you talk you produce sound. Different animals produce different sounds too.

Sense of taste



Activity 4

As a class



What to do

1. Come up with different items. Use the items to fill the table below in your exercise book .

Item	Taste				
	Sweet	Sour	Tasteless	Bitter	Salty

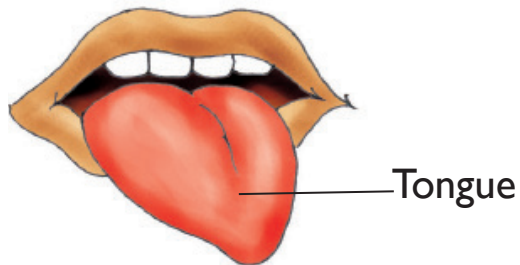

We use our tongue to tell if something is **sweet, bitter, salty** or **sour**. There are things which have no taste, as well. We say that they are **tasteless**.

Sense of smell



Activity 5

In pairs

Recite the poem below

If you smell, You have got a nose,
I do not mean smell, Like stinky toes,
Like what I meant,
Your nose knows smelling
It knows scent.....

Yes, noses! noses!

What we use for sniffing things

Like smelly shoes...

Answer the questions below

1. Compose another poem with the theme 'Sense of smell'.
2. Copy the trend of the above poem.

Learning point



Nose

Nose is the sense organ of smell. It smells both bad and good things



Sense of touch or feeling

What organ do we use to feel things?



Activity 6

Work in pairs



What to do

1. Select different items from the chart provided by your teacher.
2. Use them to fill the table below in your exercise book.

Item	Texture					
	Hard	Hot	Soft	Rough	Smooth	Cold

We use our skin to touch and feel things.



We can know about things by feeling them. For example:



- We can feel hot things.
- We can feel cold things.
- We can feel smooth things.
- We can feel soft things.
- We can feel rough things.
- We can feel sharp and pointed things.



Check your progress 3(a)

1. Match the sense organs with the correct sense.

Sense organ	Sense
 Eye	Taste
 Ear	Sight

 <p>Nose</p>	<p>Touch</p>
 <p>Tongue</p>	<p>Smell</p>

2. We feel with our _____
3. Copy and fill the table below in your exercise book.

How it feel	object
Rough	
Hot	
Sharp	
Cold	
Smooth	
Hard	



Let us talk

Look at the pictures below with a friend. What can you see?



A

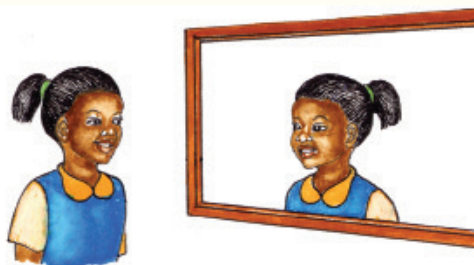

B

In picture **B**, why is the girl able to see herself on the mirror?



Activity 7

Work in a group of four



What you need

- A shiny silver coin, cardboard, mirror and wall.



What to do

1. Hold the mirror up against the sun.
2. Move the mirror around.
3. Repeat this with soft board and shiny silver coin.
4. Observe and record the observation.
 - What did you find out about light by doing this experiment?

Learning point

Image is formed when there is bouncing back of light ray on a shiny surface.



Check your progress 3(b)

1. Write 3 sources of light.
2. The bouncing back of light is called _____.
3. _____ is formed when light is reflected.
4. Copy the table below in your exercise and tick in the right box.

Material	Reflects	Does not reflect
Still water surface		
Book		
Piece of cloth		
Polished metals		
Shiny mirror		
Coin		
Piece of wood		

Echoes



Let us talk

Try playing with the ball as shown below.



What happens? Now throw the ball against a wall. What happens?

Learning point

When the ball is thrown against the wall, it bounces back. This also happens, when the sound comes across a barrier such as a wall, it bounces back. This is the sound which follows after the first sound is heard. It is normally heard when the first sound has been reflected by a hard surface. This sound is known as **Echo**.

ACTIVITY I

In groups

What to do

Study the animals in the following pictures.

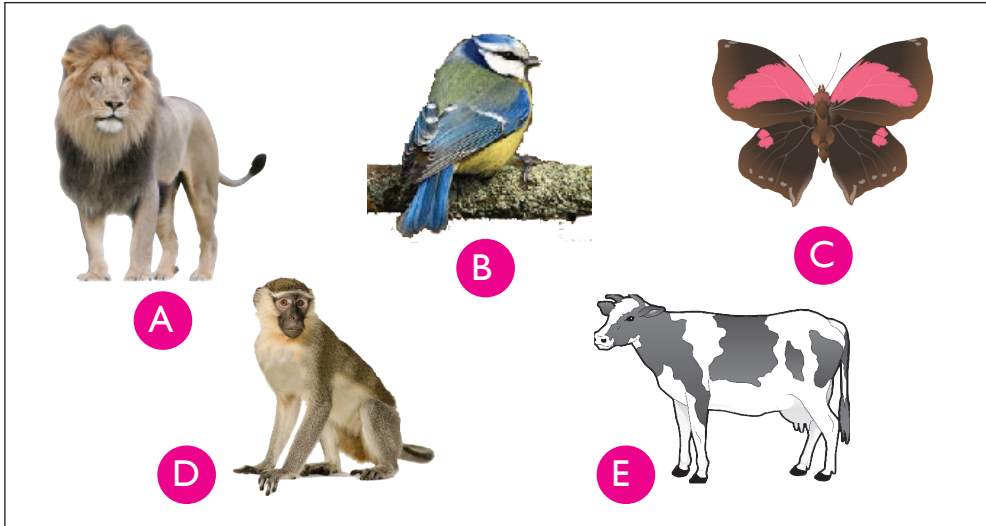

1. Name the animals shown in the picture.
2. What do each of the animals feed on?
3. Name other animals that feed on the same type of food as each of the animals in the pictures.
4. Where do each of the animals get their food from?

Learning points

Animals can be grouped according to the type of food they eat. These three groups are:

- **Herbivores** – these are animals that eat plants and plant materials only. Examples of herbivores are cattle, goats, sheep, gazelles, elephants and zebras.
- **Carnivores** – these are animals that feed on meat or flesh from other animals. Examples of carnivores are lions, wolves, leopards, cheetahs and tigers.
- **Omnivores** – these are animals that feed on both flesh and

plants. Examples of omnivores are human beings, pigs, baboons, gorillas and monkeys.

Herbivore

ACTIVITY 2

 In pairs

What to do

Study the following pictures.

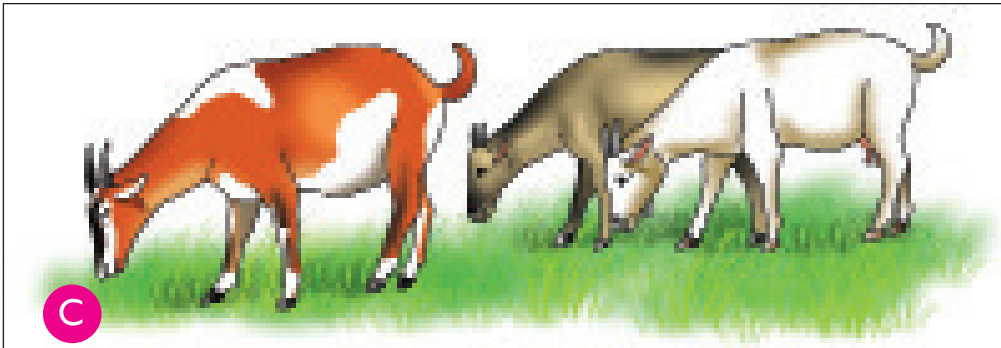
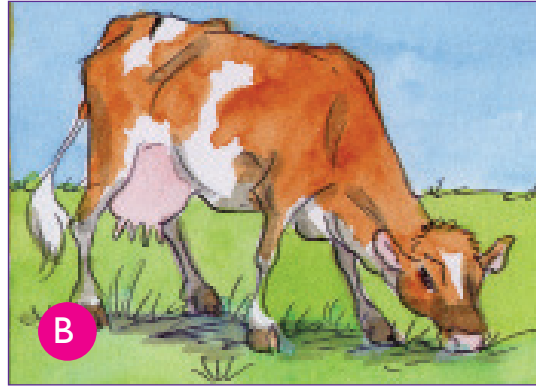
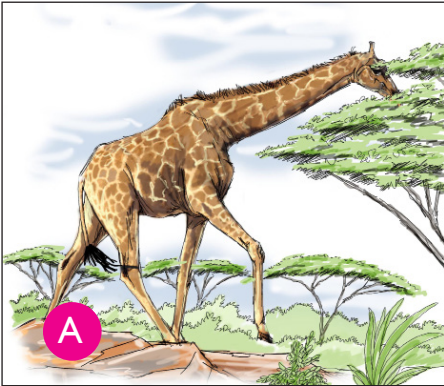

1. Name the animals in the pictures above.
2. Describe what the animals are doing. Are the animals feeding in the same manner?
3. What is the difference in the feeding methods of the animals in picture A, B and C?
4. Study the picture below.

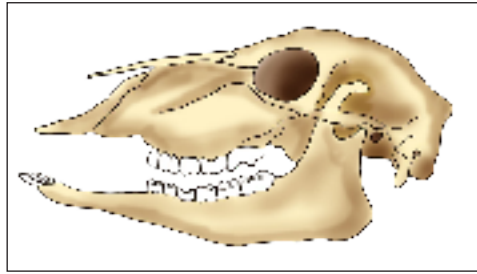

- a) How many teeth can you see on the upper jaw?
- b) How many teeth can you see on the lower jaw?
- c) Does the animal have the same number of teeth on both jaws?
- d) What do you think the animal whose teeth are shown in the skull above eats?

Learning points

- Herbivores can be classified into two groups. These are:
 - a) Grazers – These are herbivores that eat grass. Examples of grazers are cattle, sheep, gazelles and buffaloes.
 - b) Browsers – These are herbivores that feed on leaves, shrubs and trees. Examples are giraffes, dik-dik, antelopes and elephants.

Note: Goat is a browser as well as a grazer.

- Herbivores have sharp and flat incisor teeth on the lower jaw. These teeth help the animal in biting, holding and cutting plants. Some herbivores have no incisors on the upper jaws. They have a very hard horny pad instead. This helps them to hold food firmly.

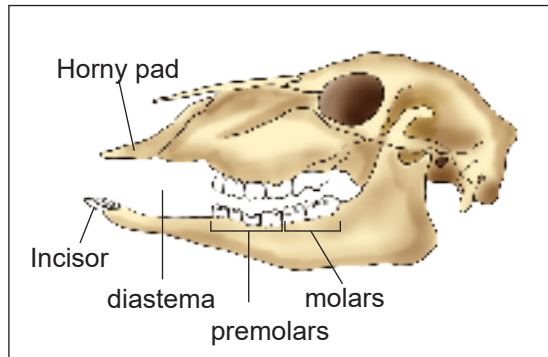

- Herbivores have large molars and premolars. These teeth are used for chewing and grinding plant parts.
- Some herbivores have a toothless gap between the incisors and the premolars in the lower jaw. This space is called diastema. It helps the animals in turning food in the mouth for proper chewing.
- Some herbivores such as giraffes have long necks and elephants have long, flexible trunks. These help the animals to reach and get soft leaves and twigs found high up on trees.

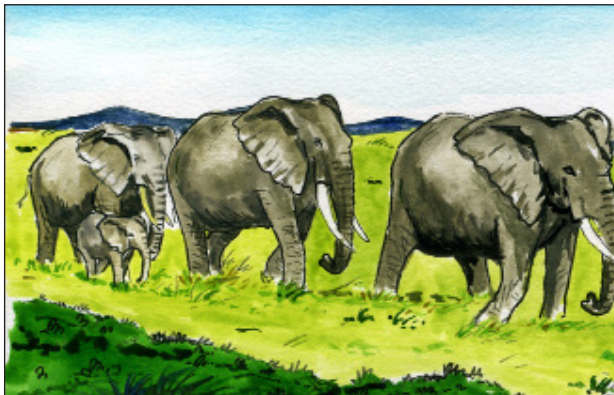

- Some herbivores do not chew their food completely. The food is stored in a special part in the stomach. The food is later brought to the mouth for proper chewing when the animal is resting. This is known as chewing cud. These herbivores have a special stomach which has four chambers. Therefore they are called ruminants. Examples of ruminants are cattle, goats, sheep and

camels. Herbivores which do not chew cud are known as non-ruminants. Examples of a non-ruminants are rabbits.

Remember!

Herbivores are animals which feed on plants or plant materials only. They can also be referred to as herbivorous animals.

Carnivores

ACTIVITY 3

Individually

What to do

Look at the following pictures

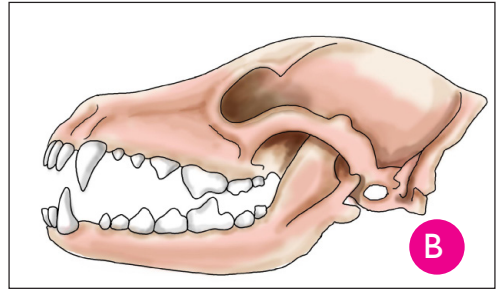

1. What is the name of the animal in picture A?
2. What is the animal doing? How did it get its food?
3. How can you group the animal according to what it is feeding on?
4. Which other animals belong to the same group as the animal in picture A? Tell your teacher.
5. Study the teeth of the animal in picture B. How are they different

from a herbivore's teeth?

6. Look at the feet of the animal shown in picture C. What do you notice?

Learning points

- Carnivores are animals that feed on meat or flesh of other animals.
- Carnivores hunt and kill other animals for food, therefore, they are called predators. The animals they hunt and kill are called preys.
- Examples of carnivores are lions, wolves, leopards, cheetahs, hyenas and tigers.
- To hunt and kill their prey, they use many ways. These include:
 - i) They have long and pointed canine teeth. Canine teeth are used to hold, choke, kill and tear flesh from their preys.
 - ii) Some carnivores can run very fast and catch their prey easily. A good example is a cheetah.
 - iii) Some carnivores such as hyenas and leopards have spots on their skins. They can use the spots to hide in the grass. This helps them to move very close to their prey before catching them.
 - iv) Most carnivores also have a good sense of sight and scent. This helps them to see and smell out their prey easily.
 - v) Many carnivores have strong and sharp claws in their paws. These helps them to catch and tear flesh from their preys.
 - vi) Some carnivores such as hyenas hunt together in groups called packs. This helps them to use less energy as they chase their

preys, one animal at a given time.

Do you know!

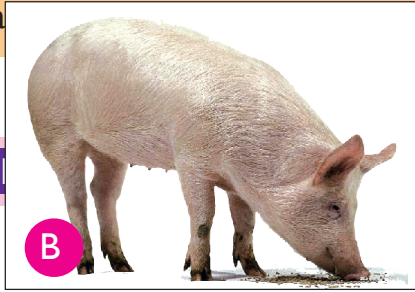

1. Name the animals shown in the picture above.
2. Study the teeth of the animal below. What do you notice?

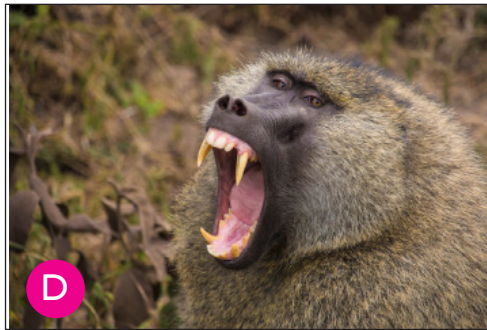

3. What do you think the animals in the picture feeds on?
4. Now tell your friend to show you his or her teeth. Compare them with those of the animals in the picture. What do you notice?
5. Tell your friend the kind of food you eat. Compare your list with the list of the food the animal in the picture eats. What do you notice?

Learning points

- Omnivores are animals that feed on both flesh and plants.
- Examples of omnivores are human beings, pigs, baboons, gorillas and monkeys.
- Omnivores have small and chisel-shaped incisors teeth for cutting and biting food. Their canines are strong, sharp and pointed for

tearing, gripping and piercing food. However, their canines are not as sharp as those of carnivores.

- They have ridged, flat and broad premolars and molars for chewing, crushing and grinding food.
- Some omnivores such as monkeys have long tails and legs. These help them to hold on to tree branches as they move from one tree to another looking for food.
- Man, monkeys, apes and baboons have fingers for gripping and grasping small foodstuffs such as grains, small insects, birds and fruits.

Birds

ACTIVITY 4

 In groups

Materials

- Old newspapers and magazines with pictures of different birds
- A camera or a smart phone with a camera
- Glue or cellotape
- A pair of scissors or a razor blade
- Exercise book

What to do

1. Collect or cut pictures of different birds from old newspapers and magazines. You can also take some photographs of birds around your home or school.
2. Paste the pictures in your science books.
3. Study the pictures of each bird carefully.
4. a) Do you know the name of each bird in the pictures that you have? Write it down if you do.
b) Study the shape of the beak of each bird in the pictures below.

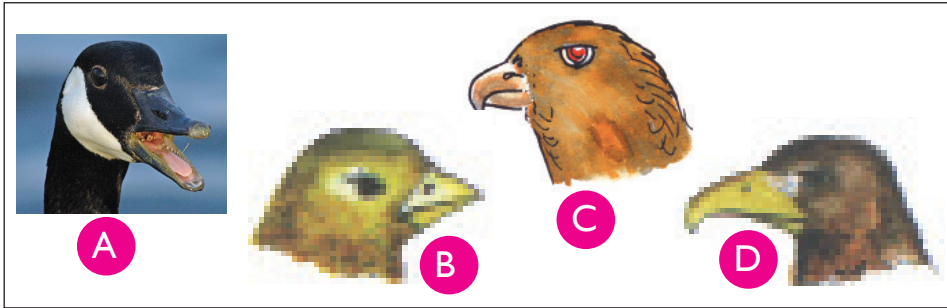

What do you think each bird eats? Find out by observing it while it feeds. Repeat this activity with many other birds.

c) Report what you have found out to your science group in class.

Learning points

- Birds can be grouped depending on what they feed on.
- To find out what a bird feeds on, we study its beak and its feet.
- **Grain eaters** are birds which feed on grains or seeds. They eat grains such as maize, millet, wheat and sorghum. Examples of grain eating birds are chicken, weaver birds, doves, pigeons and turkeys. They have a short strong, thick, straight and blunt beak.



- **Filter feeders** are birds which feed by filtering food from water and mud. Examples of filter feeders are ducks, flamingos, penguins, pelicans and swans. They have long, flat and serrated (saw-like) beaks for sieving food from the mud. They have webbed feet that help them to swim in water or walk in the mud.

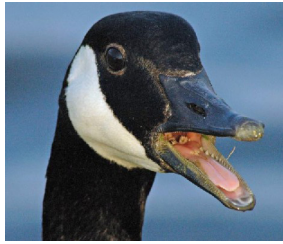

- **Flesh eaters** are birds that feed on fish or meat from small animals. Flesh eaters are also known as birds of prey. Examples of flesh eaters are owls, kites, eagles, crows and vultures. These birds have short, strong, sharp, curved or hooked beaks for cutting and tearing flesh. They have sharp claws called talons for gripping their prey. They also have good eyesight.

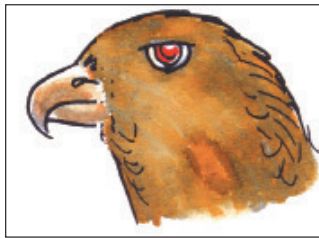

- **Nectar feeders** are birds that feed on nectar from flowers. They have long, thin, slightly curved beaks for sucking nectar from flowers. They are small in size and light in weight. These enable them to land on thin branches supporting the flowers. Examples of nectar feeders are humming birds and sunbirds.

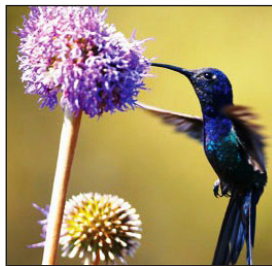

- **Fruit eaters** are birds that have straight and sharp beaks. Example of fruit eaters are woodpecker and mockingbird.



Insects

ACTIVITY 5

 As a class

Materials

- A hand catching net for catching insects
- A hand magnifying glass
- Containers with lids

What to do

1. With the help of your teacher, walk around your school compound. Collect as many insects as you can using the hand catching net to trap insects that fly. Put the collected insects in the containers and close the lids.

Warning! Do not touch some insects using your bare hands. Use a stick as some insects can bite for example termites while others can sting for example bees and wasps.

2. Bring the insects you have collected to class. In your science groups, use a hand magnifying glass to study the mouth of each insect and fill the following table.
3. Compare and discuss your table with other groups.

Name of insect	Has teeth	Has proboscis	What does it feed on?
Housefly			
Termite			

Butterfly			
Cockroach			
Tsetse fly			
Bee			
Ant			
Ladybird			
Grasshopper			

Learning points

- Different insects feed on different things as shown below.



- Insects with chewing mouthparts have teeth - like structures called mandibles, for example grasshopper, cockroaches and beetles. They all feed on hard plant materials.
- Insects with piercing and sucking mouthparts feed on blood, for example mosquitoes, bedbugs, tsetse flies, sand flies and blackflies.
- Some insects have a sharp mouthpart called proboscis. The mouthpart is used to suck blood from other animals or nectar from flowers. The proboscis can be short like in bees or long like in butterflies.
- Houseflies have a dabbing and sucking mouthparts for feeding on decomposing organic matter.

2.2 Interdependence of living things

Investigating interdependence among living things

ACTIVITY 6

 As a class

Study the following pictures.

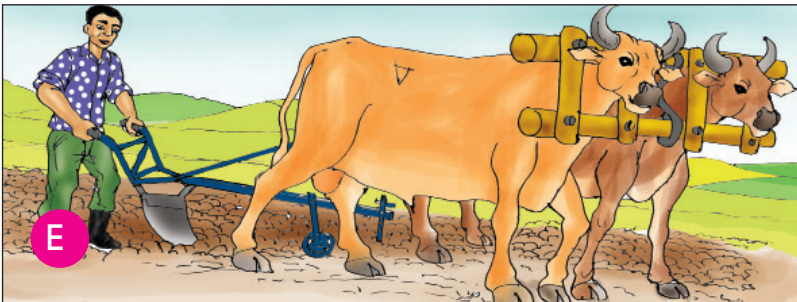
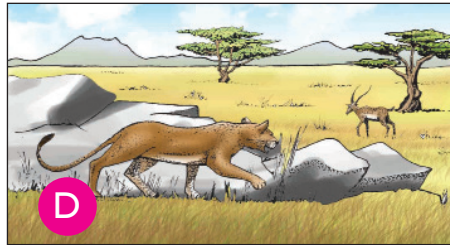
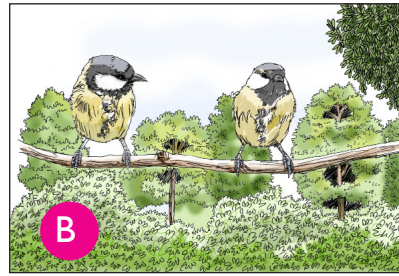

1. What are the people in Picture A doing? What do you think they will do with the crops?
2. Can you see birds in picture B? What is the monkey in picture C doing? How are the trees helping the monkey and the birds? Tell your teacher.
3. What is the leopard in picture D doing? How is the gazelle important to the leopard?
4. What is the person in picture E doing? How are the oxen important

to farmers?

5. How are organisms in each picture important to each other?

Learning points

- An animal or a plant cannot live by itself. It depends on other animals and plants for survival.
- Plants and animals depend on each other for support and in their feeding habits. This is called interdependence. The interdependence between animals and plants can be shown using a food chain.
- A food chain shows who eats who. The arrow always points at the eater. A food chain, therefore, shows how animals get food directly or indirectly from plants.
- Examples of food chains are shown below.

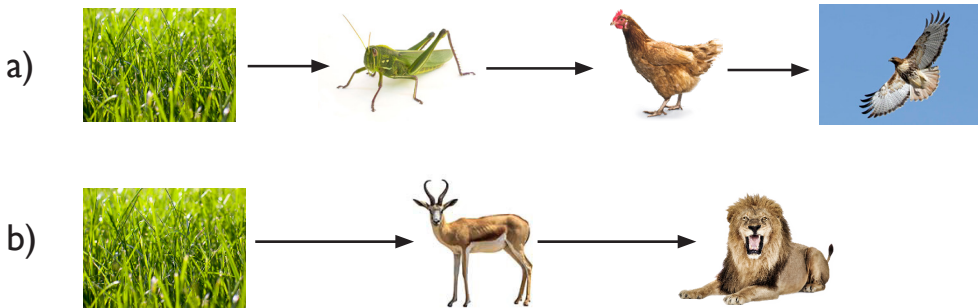

Investigating interdependence between plants

ACTIVITY 7

 As a class

Materials

- An exercise book to record findings.
- A pen or pencil to write.

What to do

1. Go outside your classroom and walk around the school compound.
2. Study and observe the plants to find out how they depend on

each other.

3. Identify plants that are:
 - i) Growing on other plants.
 - ii) Growing under the shade of other plants.
 - iii) Climbing other plants.
4. Record your observation as shown in the table below.

Name of plant	Where the plant is found	Depends on other plants for (support, shade, habitat)

Learning points

Plants may depend on each other for:

- Some plants such as peas and passion fruits have soft and weak stems. Therefore, they cannot grow upright on their own. These plants depend on other plants which have stronger stems for support. These plants are called climbers or creepers. They have hooks and tendrils. These enables them to climb onto other plants.
- Some plants are parasites. Therefore, they grow on other plants called hosts. Parasites depend on their hosts for shelter and nutrients. Parasitic plants have their roots attached to the host plant. Examples are striga weed which depends on maize and sorghum for survival.
- Some plants grow under other plants. In this way, they are protected from strong sunlight. This helps them to reduce loss

of water from their leaves.

Investigating how plants and animals depend on each other

ACTIVITY 8

 As a class

Materials

- An exercise book to record your findings and observations.
- Pens and pencils to write and draw.

What to do

1. Go outside your classroom and observe the surrounding.
2. Observe plants and animals. Look out for the following:
 - a) Any small animals plants. Look out for bees, grasshoppers, small creeping animals and butterflies.
 - b) Large animals such as cows, goats, sheep and chicken feeding on grass or other plants.
 - c) Observe whether there are any birds eating seeds.
 - d) Observe the ground or soil. Look out for any animal droppings or manure and other small animals such as earthworms.
3. Identify other things in the environment, for example, crops, flowers, houses and playing fields that show how people depend on plants.
4. Discuss the following questions:
 - a) What do you need from plants?
 - b) What do plants need from animals?
 - c) Which animals depend on plants and for what reasons?

Learning points

Plants and animals depend on each other for:

- Most green plants use sunlight to make their own food. Animals directly or indirectly depend on plants for food. Some special plants called insectivorous plants depend on animals for food. They trap

and digest insects to obtain nutrients. Examples of insectivorous plants are pitcher plant, butterwort plant and venus fly trap.

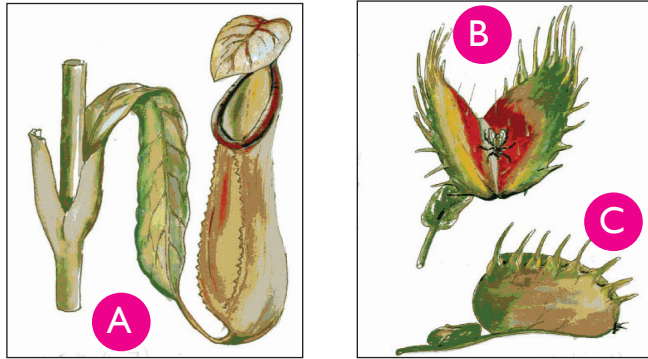

A - Pitcher plant B and C - Venus fly trap

- Forests provide a natural home for most bird and wild animals. Some animals such as birds build nests on trees. Animals lie or stand under the shade of trees when it is hot.

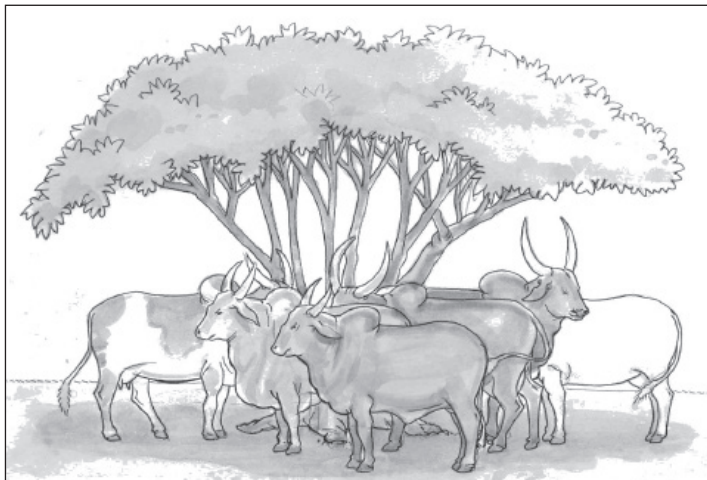

- **Nutrients:** nutrients are things required for the healthy growth of plants and animals. Plants obtain nutrients from the soil. These nutrients can be from animal wastes such as manure (dung and urine) or dead and decayed animals and plants.
- **Medicines:** we get herbal medicine from plants such as Neem tree, garlic, turmeric, gingers, seaweed, aloe vera, eucalyptus and many other plants.

- **Pollination:** many plants depend on animals such as bees and butterflies for pollination. These animals pollinate flowers as they move from one plant to another.



- Plants use carbon dioxide breathed out by animal to make their own food. In the process, oxygen is produced as a waste product. The oxygen is used by animals in breathing.

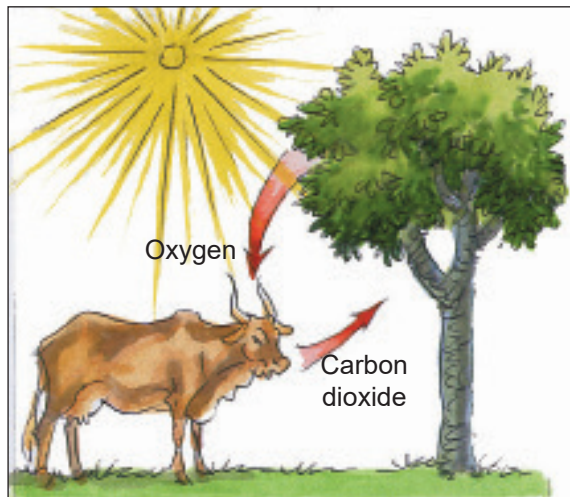

- Plants make our homesteads and environment beautiful.
- Plants rely on animals, wind and water to help scatter their seeds.

2.3 Conservation of plants and animals

Investigating ways of conserving plants

ACTIVITY 9

 Individually



Materials

- An exercise book to record your observation and findings.
- Pens and pencils is to write and draw what you observe.

What to do

1. Go outside your classroom and observe the surrounding.
2. Look out for the following:
 - a) Are there big plants?
 - b) Are there small plants?
 - c) Which of the plants grew naturally? Which ones were planted?
 - d) What is the importance of these plants in the school environment?
3. Draw and complete a table like the one shown below. Fill in the missing details as you discuss in your science groups. You can also draw some of the plants. Note that you can use local names of plants.

Name of plant	Small plant	Planted or grew naturally	Importance of the plant to the environment
Grass			
Trees			
Flowers			

Learning points

- We should keep the grass in our compounds short. Gardens in our homes and school compound should be weeded regularly. Weeding should be done during the dry seasons. This will help the plants to grow well.





- Roots of many plants help to prevent soil erosion. Soil erosion is the removal of fertile topsoil by strong winds or moving water. Roots of plants hold soil particles together hence preventing soil erosion.

Did you know?

A botanic garden is a place where many different type of plants are grown.

Investigating ways of conserving animals

ACTIVITY 10

 As a class

Materials

- An exercise book to record your findings and observations.
- Pens and pencils to write and draw what you observe.
- A camera or a smartphone with a camera.

Your science teacher will take you on a field trip or an educational visit to a national park, a farm or a zoo.

What to do

1. Observe the animals. Look out for the following:
 - i) What are the names of the animals that you have observed?

- ii) Why are the animals kept in the zoo?
- iii) What kind of food does each of the animals feed on?
- iv) Classify the animals according to what they feed on.
- v) Draw and complete the following table.

	Name of animal	What the animal eats	Classification	Reasons for keeping the animals
a)				
b)				
c)				
d)				
e)				
f)				
g)				
h)				
i)				

2. Discuss what you have filled in your table with members of your science group and with the rest of the class.

Remember!

Animals can be classified as herbivores, carnivores or omnivores.

Learning points

- To conserve means to protect, preserve or keep in a good condition for future use.
- It is important to conserve plants and animals because they are part of our heritage.
- Conservation of plants and animals also helps to stop them from becoming extinct. When an animal or plant becomes extinct it means it stops to exist.



- Animals and plants are conserved using different methods:
 - i) Wild animals and plants can be conserved by keeping them in a national park or botanical gardens. In the parks, the animals live in their natural habitats. They are protected from people who may want to kill them.
 - ii) Some animals are conserved by keeping them in a zoo. Zoos are protected areas. In the zoo, people may go to see the animals that are kept there.
 - iii) Domestic animals and plants are kept by people at home or in farms.
 - iv) Young animals without parents can also be kept in an animal orphanage. In the orphanage, they are protected and taken care of until they become big. Later on, they can be transferred to a zoo or a national park.

2.4 Effects of climate change on animals and plants

ACTIVITY 10

In groups

What to do

Study the following pictures.





1. What effects of climate change are shown in the pictures?
2. In your groups, discuss the effects of climate change on both animals and plants as shown in the picture.
3. Write down in your exercise book the effects of climate you have discussed from the photographs above
4. Think of other effects of climate change on plant and animals and write them down as you discuss with your teacher.

Learning points

- Climate change refers to the extreme changes in overall weather patterns on earth. It could be due to temperature changes or the amount of rainfall a place receives.
- Climate change affect both animals and plants.

Effects of climate change in plants include:

- i) Drying up of plants when the weather is too hot.
- ii) Rotting of some parts of the plants when there is too much water.

Effect of climate change in animals include:

- i) Floods can kill animals by drowning. It can also lead to spread of diseases.
- iii) Prolonged droughts, may force some animals to migrate or move to other places where they can find food.

Remember!

Climate change can also affect human activities such as farming and draught. These leads to lack of pastures and crop failure.

Check your progress 2.7

1. Write down two reasons why we conserve plants.
2. Write down two things we can do to take good care of flowers growing in the school compound.
3. A class 4 science teacher took his class on an educational trip. They visited a place where animals were conserved in their natural habitats. This place was most likely a _____.
4. What two animals are the pupils likely to observe when they visit the place mentioned in question 4 above?
5. How does climate change affect animals?

Words to learn

Temperature, weather, sunny, rain cloudy,
wind, forecast.

Weather changes

Today's Weather



Let us talk

Look outside at the weather. Talk to your friend about the weather today. Is it the same as yesterday's?

In which weather does the school flag fly?

In which weather do clothes dry?

Learning point

Weather refers to the day to day changes in the atmosphere. The weather is not always the same. The changes may be described as:



Sunny



Cloudy



Windy



Rainy



Calm



Activity 1

As a class



Recite the poem below.

Whatever the weather.
We have it each day.
It's hot or it's cold,
Or it's sunny or rainy,
It's windy or calm,
There is some kind of weather,
Each day of the year!

Answer this question

1. What do you learn from the poem?
2. Come up with a poem of the same type that include different days of the week.



Learning point

A change in weather influences our daily activities. We also dress according to different weather. Some of the activities influenced by weather include:



Putting on a short and vest on a sunny day



Using an umbrella when its raining



Flying a kite under influence of wind







Putting on warm clothes



Check your progress 5(a)

1. We see the sun during the _____
2. Match the weather symbols with their names correctly.

Weather symbol	Name
a) 	Calm
b) 	Rainy
c) 	Cloudy
d) 	Windy
e) 	Sunny

3. Name three types of clothes we wear on a cold day and during a hot day.
4. The best day to fly a kite is when the weather is _____.
5. When it is rainy we cover ourselves with _____.

Air pressure



Activity 2

In pairs



What you need

Balloons, balls



What to do

1. Blow air into a balloon and hold the neck tightly



2. Put the balloon in front of your face and release the neck.
 - What do you feel?
3. Put air in the balloon.
4. Release the balloon and observe how far it will travel.

Learning point

When you release a balloon full of air onto your face, you will feel some force from the balloon. This shows that air exerts pressure. We inflate a balloon with air. Air is a mixture of different gases. A balloon will burst if too much air is inflated into it. A balloon will burst because the air in it is at higher pressure than its surrounding.



Check your progress 5(b)

1. We inflate balloons with _____
2. What causes bursting of the balloons?

Recording weather changes

Activity 3

Work in pairs



What to do

1. Your teacher will help you to make a wall chart on a hard paper.
2. Use weather symbols to show the weather conditions for each day of the week.

Mon	Tue	Wed	Thur	Fri

Learning point

We use table to record different weather condition. Different weather symbols are used.



Check your progress 5(c)

At the end of the week, answer the following questions

- i. What kind of weather did you see the most? The least?
- ii. What other kinds of weather could you have seen?
- iii. How many days did it rain?
- iv. How many days had the same kind of weather?
- v. How many days had more than one kind of weather?
- vi. Predict the weather for next week, monitor it and then note down the accuracy of predictions.

Materials

- Water
- Clear plastic bottles
- Cooking pot
- Stove
- Match box
- Refrigerator or freezer

What to do

1. Put water in one of the clear plastic bottles.
2. Pour water in the bottle into the cooking pot.
3. Observe as water pours into the cooking pot.
 - What so you see?
 - Can you put your finger into the water?
 - Is your finger wet or dry after feeling the water?
 - What is the state of water in the bottle and in the cooking pot?
4. Light the stove.
5. Place the cooking pot with water on the stove gently. Let the water boil.
6. Observe what happens. Can you see the steam (vapour)?

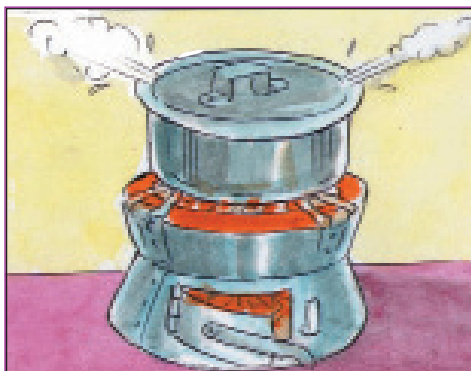

7. Record the observation in a table like the one below.

Water	State
Water in the bottle	
Water when boiling	

8. Put water in the second clear plastic bottle. What is the state of water as you pour it into the bottle?
9. Place the bottle of water in a freezer or refrigerator. Observe the water after a day. Record the observation in the following table.

Water	State
Water in the bottle before refrigeration.	
Water in the bottle after refrigeration.	

10. Discuss your observation in groups and present your results in class.

Learning points

- Water can exist in three states.
- Water that flows and can be held in a container is in liquid state.
- When water is heated until it boils, it forms steam (vapour). Steam is water in form of a gas.
- When water is put in a very cold place like in a refrigerator, it becomes ice. Ice is water in solid state.

Changes of state of water

Activity 1

 As a class

Materials

- Cooking pot and lid
- Stove
- Match box,
- Ice cubes

What to do

1. Light the stove.
2. Put ice cubes in the cooking pot.
3. Place the cooking pot on the lit stove. What happens to the ice cubes? What is the name given to the change of state when ice cubes are heated?



4. Place the lid on the cooking pot. after some time. Remove the lid carefully after a few minutes. What do you observe in the inner surface (lower side) of the lid:
 - A. What is the change of state when water boils and becomes steam?
 - B. What is the change of state when steam is cooled and becomes liquid water?
5. Record your observations in a table like the one shown below.

Case	Observation	Conclusion

6. Discuss what would happen in A and B if:
 - a) the source of heat is removed
 - b) Amount of heat is increased
7. Record your results in a table like the one shown below.

	Prediction
Source of heat is removed	A.
	B.
Amount of heat is increased	A.
	B.

Learning points

- Water in solid state (ice) changes to liquid state when heated.



- The process of changing a solid to a liquid is called melting.
- Liquid water changes to vapour (steam) when heated.
- The process of changing a liquid to a gas like water vapour is called evaporation.
- Water vapour changes to liquid water when cooled.
- The process of changing water vapour back to liquid water is called condensation.
- Liquid water changes to ice when frozen.
- The process of changing a liquid to a solid is called freezing.
- Temperature determines the state in which water is.
- Increase in temperature makes water in solid state to become liquid. It also makes liquid water to become a gas. Low temperature makes water in form of a gas to become liquid. Very low temperature makes liquid water to become solid.

Below is a diagram that shows the changes of state that occurs in matter

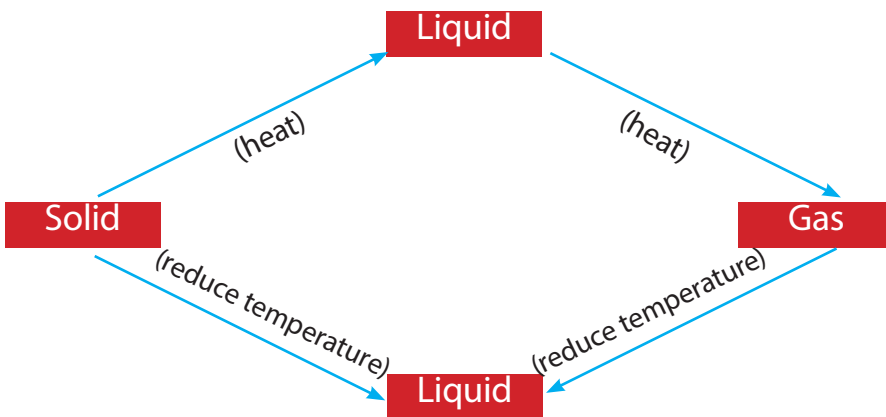

1. The states in which water exists depends on.

A. light	C. time
B. temperature	D. volume
2. Name the process marked P, Q, R and S.

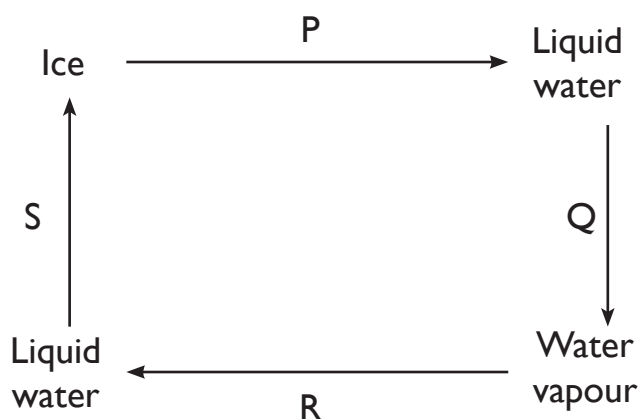

3. Write true or false.

- i) Condensation occurs when a solid changes into a liquid.
- ii) Ice is water in solid states.

4.2 Physical properties of water

Activity 2

 As a class

Materials

- Water
- Bottles of different shapes

What to do

1. Pour equal amounts of water in bottles of different shapes.
2. Observe the appearance of water in the bottles.
3. Record your observation in a table like the one shown below.

Investigation	Observation	Conclusion
Shape of container		

- Was it easy to pour water into the bottles?
- Can water flow out in a bottle?
- How can you describe the shape of water in the bottles? Is it fixed or does it take the shape of the bottles?

Learning points

- Water does not have a regular or fixed shape. It takes the shape of the holding container.
- The volume of the water remains the same even when it is changed from one container to the other.
- The mass of the water remains the same even when it is changed from one container to the other.

1. Look at the diagram below.



The diagram show that

- A. water has a definite mass.
 - B. water has no definite shape.
 - C. water has a definite volume.
2. Which one of the following is not true about water?
 - A. Water has a definite volume.
 - B. Water has a definite mass.

- C. Water has a definite shape.
3. Write true or false for the following statements.
- A. Water takes the shape of the container.
- B. Water cannot flow when poured.
- C. Liquids do not have definite volumes.

Remember!

- Water has a definite volume.
- Water has a definite mass.
- Water has no definite shape.

4.3 Solubility of substances in water

Activity 3

 In pairs

Materials

- Water
- Soil
- Glass
- Bottles
- Stirring rod or spoon
- Flour
- Powdered milk
- Chalk dust
- Ash
- Glucose
- Sugar
- Salt
- Maize

What to do

1. Half fill the glass with clean water.
2. Put crushed sugar in the glass of water.
3. Stir the sugar in water using a stirring rod or spoon.



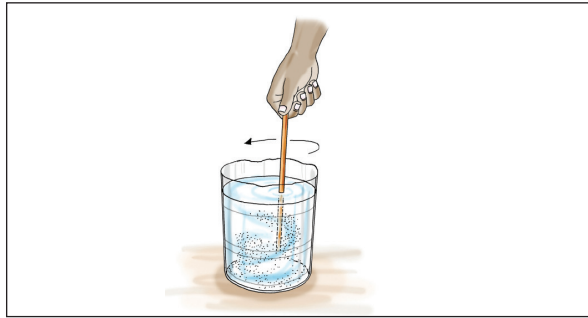

4. Make observations:
 - Why is the sugar no longer visible?
 - How can you be sure that the sugar is still there?
 - What do we get when a solid dissolves in a liquid?
5. Repeat the step 2 and 3 using different substances such as glucose, salt, maize flour, powdered milk, chalk dust, ash and soil.
 - Which substances dissolved in water?
 - Which substances did not dissolve in water?
 - Does stirring substances help them to dissolve faster?
6. Record your observations in the table below. Put a tick (✓) in the appropriate column.

Substance	Soluble	Insoluble

7. Discuss your findings in class.

Learning points

- Solubility is the ability of a substance to dissolve in a solvent at a given temperature and pressure.
- A substance that dissolves in a liquid is called a solute.
- A substance that does not dissolve in a liquid is said to be an insoluble solid.
- The liquid in which substances dissolve is called a solvent.
- Water is a good solvent because it allows many substances to

dissolve in it.

- A mixture of a solute and a solvent is called a solution.
- Sugar + Water = Sugary water
- (Solute) (Solvent) (Solution)
- We can make substances to dissolve faster by:
 - Crushing particles to make them smaller.
 - Stirring the mixture.
 - Shaking the mixture.
 - Using warm water.
- When a substance mixes with water completely a uniform solution is formed. A uniform solution is called a homogenous solution.

Remember!

- Water has a definite volume.
- Water has a definite mass.
- Water has no definite shape.



Activity 1

 In pairs

What to do

1. Look at the things found in your classroom.
2. List all the things you can see in your exercise book.
3. Discuss the things you have listed:
 - (i) What is each object made of?
 - (ii) Can you push or touch each of the objects?
 - (iii) Does it keep the same shape throughout?
4. Use a dictionary to find the meaning of the word matter.

Learning points

- Matter is everything around us.
- Matter is anything that has mass and occupies space. This means that we can weigh or measure matter.
- Mass is the quantity of matter in an object.
- Examples of matter are clothes, plants, animals, water, food and air.
- We use different kinds of matter to make different objects. We can make something such as a metallic or plastic spoon. In this example, we say the material used was metal or plastic.

Activity 4

 In pairs

Materials

- | | | |
|-----------------|---------|--------------------|
| • Exercise book | • Desk | • Glue |
| • Ruler | • Water | • Inflated balloon |
| • Set | • Ink | |

What to do

1. Study the materials. How do you classify these objects?
 - (a) Do they have regular shapes or sizes? Compare them to

shapes like squares, rectangles, circles, and ovals.

(b) How hard or soft are they?

2. Record your observations in the table below.

Materials with a regular shape	Materials with an irregular shape

Learning points

- You noticed that the materials have different shapes and sizes.
- Matter can be put in three different groups namely:
1. Solids 2. Liquids 3. Gases
- These groups are commonly called states of matter.
- One important way of classifying objects is by their states of matter.

Remember!

Some materials are solids, some are liquids and some are gases. A material will always be one of these three states.

1. Name any three objects we use at home that are made up of matter.
2. The amount of matter in an object is called _____.
3. Give reasons why a block of wood is an example of matter.
4. Write True or False.
 - (a) Rain is made up of matter.
 - (b) Air has no mass.
 - (c) The food we eat is made up of matter.
 - (d) We cannot see all matter.



5.2 Physical properties of solids, liquids and gases

Solids

Activity 4

In groups

What to do

Look at the picture below

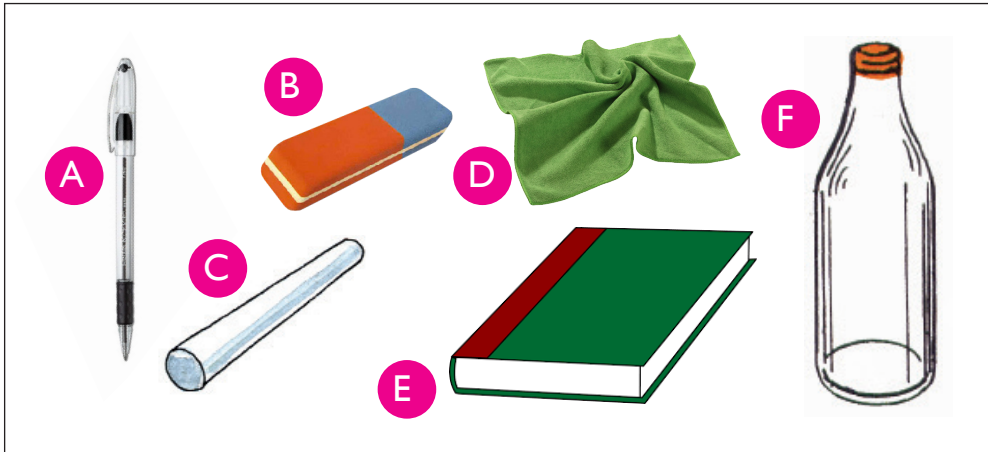

1. Describe the objects in the pictures above.
2. Your teacher will give you some of the objects.
 - (a) Touch each object. Does it feel hard or soft?
 - (b) Knock each object. Does it make a sound?
 - (c) Can you put your finger through each object?
 - (d) Put each object into something such as a basin or small container. Does it change its shape?
 - (e) How would you describe the shape of each object? Is it fixed?
 - (f) What do all the objects have in common?

Learning points

- You will notice that the shapes of the objects do not change. The shapes remain the same even after putting them into another container. This also means that the space they occupy do not change.
- Materials which have fixed shapes and sizes are called solids.

- Solids have fixed volumes.
- Some solids are hard while others are soft.
- Examples of solids are trees, pens, pencils, stones, cooking fat and wood.

Liquids

Activity 5

 In groups

Materials

- Water
- Glue
- Methylated spirit
- Slanting platform
- Cooking oil
- Engine oil
- Containers of different shapes
- Pieces of cloth

What to do

1. Fill all the containers with the same amount of water. What happens?
2. Pour different liquids on a slanting platform. What happens?
3. Using each liquid check for the following.
 - Do they flow? If yes, do they flow at the same speed?
 - How do the different liquids smell? Do not taste the liquids.
 - Can you put your finger through the liquids?
 - Can you soak the liquids up with a piece of cloth?
4. Record your observations.

Learning points

- You will notice that water fills up different containers.
- The shape of the containers and that of water are the same. This means that liquids do not have fixed shapes. They take up the



shapes of the containers they are put in.

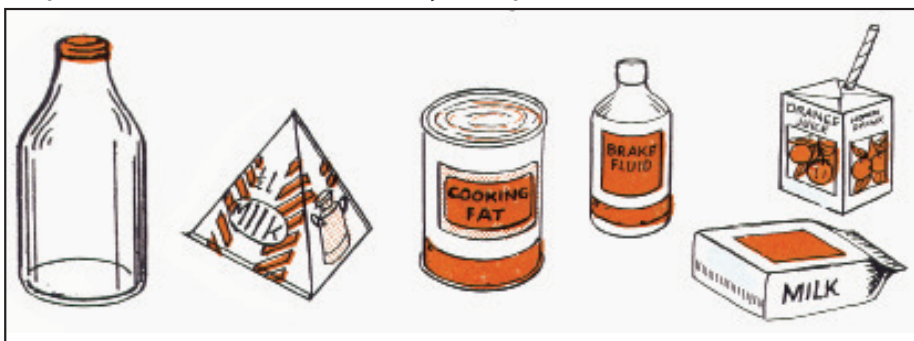

- When liquids are poured, they flow. Some liquids flow faster than others.
- We can, therefore, say, that matter that has a fixed volume, no fixed shape and can flow is called a liquid.
- Examples of liquids are water, cooking oil, juice, engine oil and methylated spirit.

Gases

Activity 5

 In pairs

Materials

- Balloons
- Strings

What to do

1. Blow air into the balloons. Then tie the mouths of the balloons using strings as shown in this picture.
 - (a) What is the shape of the balloons after blowing air into them?
 - (b) Is the air taking up space in the balloons?
 - (c) Is the air made up of something? Does it have mass?
2. Hold your chest. Then take a deep breathe. Slowly let out the breathed air.
 - (a) Can the air be seen?
 - (b) What is the smell of air?

- (c) Does the air we breathe in take up space in our lungs?
3. What happens when you hit an inflated soccer ball on the ground?

Learning points

- When a balloon is filled with air it becomes bigger. This is because air occupies space. The balloon goes back to its original shape when the air in it is released.
- We cannot see air. We only see its effects, for example, making the balloon bigger and moving tree branches.
- Air is an example of a gas and so is steam also called water vapour.
- Gases do not have fixed shapes. They spread all over to fill the containers they are put in.
- Gases have no fixed volumes. They can, therefore, be pressed or squeezed to fill smaller spaces.

Fun corner

Get balloons of different colours. Blow air into the balloons and tie the mouths with strings. Then stick them on your classroom walls to decorate the walls.

5.4 Methods of separating mixtures

Activity 6

 As a class

Story of Ayol

Ayol was sent to buy salt by his mother from a nearby shop. As he was hurrying home, he tripped and fell. The packet of salt fell and burst open, spilling the salt on the ground. He quickly scooped the salt back into the packet. However, it was mixed with some soil.

Ayol needs to separate the mixture of salt and the soil. As a friend, what would you tell him to do?



Learning points

- A mixture is two or more different materials mixed together.
- There are many different types of mixtures. Examples are:
 - (a) Solid mixtures such as maize and rice mixture.
 - (b) A solid and a liquid mixture such as sand and water mixture.
 - (c) Liquid mixtures such as kerosene and water mixture.
- Some solids like sugar and salt dissolve in liquids like water.
- There are different methods of separating mixtures.
- The method used to separate a mixture depends on the things that make up the mixture.
- The methods of separating mixtures include:
 1. Winnowing
 2. Sieving
 3. Using magnets
 4. Dissolving and evaporation
 5. Decanting
 6. Filtering
 7. Sorting (separating beans from maize, grain mixture)
 8. Curdling (separating cheese from milk)

Winnowing

How do people in your community separate grains from chaff or husks after harvesting?

Activity 7

 In groups

Materials

- Grains or seeds
- Chaff
- Tray

What to do

1. Mix the grains and chaff on the tray.
2. Go outside your classroom on a windy day.
3. Toss the mixture up and down continuously. What happens?

Learning points

- The chaff or husks are blown away by wind leaving the grains. This is because they are the light part of the mixture.
- Winnowing is used to separate light and heavy solids in a mixture.



- Winnowing is best done when strong wind is blowing.

Remember!

The husks blown away by wind should be collected and put in a litter bin. This keeps the environment clean.

Sieving

Activity 8

 In pairs

What to do

1. Study the diagram below and discuss it.

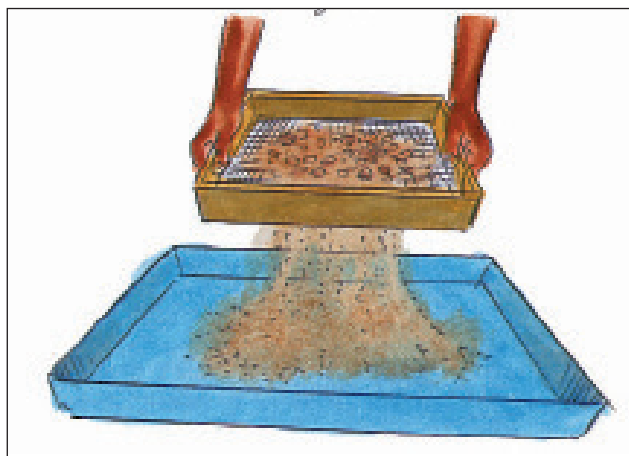

2. What mixtures can you separate using the method shown above?

Activity 9

 As a class

Materials

- Sieve
- A mixture of rice and flour
- Basin,

What to do

1. Place the sieve right above the basin.
2. Pour the mixture of flour and rice onto the sieve.
3. Shake the sieve. What happens?

Learning point

- Sieving separates large and small (fine) solid mixtures.

Using magnets

Activity 11

 As a class

Your teacher will give you a radio speaker.

1. Place a nail close to the speaker. What happens to the nail?
2. Explain the observation made.
3. Study the magnet below.

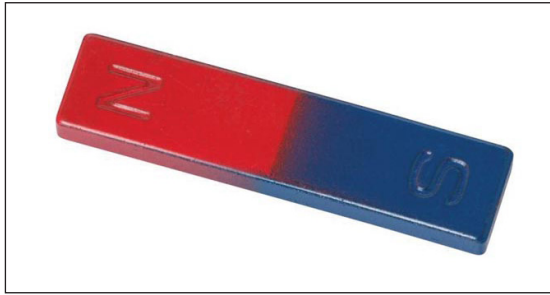

What happens when you place the magnet near some metals?

Activity 10

 In groups

Materials

- Bar magnets
- Sand
- Staple pins
- Paper

What to do

- Pour the mixture of sand and staple pins on a paper.
- Place the magnet close to the mixture. What happens?

Learning points

- A magnet is a special type of metal that attracts certain materials.
- A magnet has two ends called poles.
- A magnet is used to separate mixtures made of magnetic materials and non-magnetic materials.
- The magnetic material is attracted by the magnet leaving behind the non-magnetic material.
- Examples of magnetic materials are iron, steel and tin.
- Non-magnetic materials are materials that are not attracted by a magnet.
- Examples of non-magnetic materials are sand, wood, aluminium and copper.

Separating mixtures that contain a solid and a liquid

Activity 12

 Individually

What to do

Group the materials into those that can dissolve and those that do not dissolve. Fill in the answers in a table like the one shown.

Sugar, salt, sand, flour, glucose and powder milk.

Materials that dissolve	Materials that do not dissolve

Learning points

- To dissolve is to mix completely into a liquid.
- Some solids dissolve in liquids and some do not dissolve.
- Solids that dissolve in liquids are called soluble solids.
- Solids that do not dissolve in liquids are called insoluble solids.
- Materials which do not dissolve can be separated by:
 1. Decanting
 2. Filtering

Decanting

Activity 13

 In groups

Materials

- Water
- Two glass bottles
- Sand

What to do

1. Pour water into a glass.
2. Add sand to the water in the glass and shake.
3. Allow the mixture to settle as shown below. What do you notice? Can you still see the sand?
4. Lift the bottle carefully. Make sure you do not disturb the sand at

the bottom.

5. Pour out the water gently, leaving the sand particles in the bottle.

Learning points

- When water and sand are mixed, the sand settles at the bottom of the bottle.
- Sand does not dissolve in water.
- A mixture of sand and water can be separated by decanting.
- The water is gently poured into a separate container leaving the sand behind.
- The sand particles that remain in the bottle are called sediments.
- Decanting can also be used to separate two liquids which do not mix. Examples are:
 - a) Water and kerosene.
 - b) Water and cooking oil.
 - c) Milk and cooking oil.

Activity 14

 As a class

Materials

- Water
- Kerosene
- Two bottles or containers.

What to do

1. Pour water into the bottle.
2. Add kerosene into the bottle and shake. Let it settle. What happens?
3. How would you separate the mixture of water and kerosene?
4. Carefully pour out the kerosene into an empty bottle or container. What do you observe?

Learning points

- To separate them, kerosene is carefully poured out into another



container.

- This is called decanting.
- Decanting can be used to separate two liquids which do not mix.

Filtration

Activity 15

 In groups

Materials

- Flour
- Two small clear containers
- Water
- Piece of cloth
- Rubber band or string

What to do

1. Mix flour and water in the container.
2. Shake well and leave the mixture to settle.
 - What happens to the flour?
 - Can you still see the flour in water?
 - How can you separate the mixture formed?
3. Tie a piece of cloth onto the mouth of a bottle using a rubber band or string.
4. Gently pour the mixture over the cloth.
 - What do you observe on the piece of cloth?
 - What do you see inside the bottle?

Learning points

- When a mixture of water and flour is poured through a piece of cloth, water passes through the cloth but the flour is collected on the cloth. This method is called filtration.
- Filtration is used to remove small insoluble solids in liquids.
- Filtration uses a filter. A filter is like a sieve with very small pores.



Remember!

Filtered water should be boiled to make it safe for drinking.
Boiling kills germs in the water.

Evaporation

Activity 16

 As a class

Materials

- Water
- Sugar
- Small transparent bottle
- Source of heat
- Cooking pan

What to do

1. Pour sugar into the bottle.
2. Add water into the bottle and shake.
 - What do you observe in the bottle?
 - Can you still see the sugar in the water?
 - What happens to the sugar?
3. Pour the mixture into the cooking pot.
4. Put the cooking pot onto the source of heat. Let the mixture boil until all the water evaporates.
 - What do you notice in the cooking pot?
 - Where does the water disappear to?

Learning points

- Sugar dissolves in water. This forms a sugar solution.
- When sugar solution is heated, water evaporates. This leaves behind sugar in the cooking pot.
- Solids which dissolve in water are separated by evaporation.
- In evaporation, water changes to water vapour which is lost into the air.
- The solid is left at the bottom of the cooking pot.



Remember!

In evaporation, only the solid (solute) is recovered. The liquid evaporates and is lost in the air.

Check your progress 5.9

1. Fill in the table by ticking against solids that dissolve or do not dissolve in water.

Solid	Dissolves in water	Does not dissolve in water
Sand		
Sugar		
Salt		
Flour		
Chalk dust		

2. What does a liquid turn into when it evaporates?
A. Liquid. B. Solid. C. Vapour. D. Paste.
3. How do we get sugar out of a solution?
A. We can melt the sugar.
B. By evaporating water so that sugar is left behind.
C. By filtering it from the solution.
D. By decanting.
4. Write True or False.
(a) Evaporation occurs after boiling.
(b) A mixture of salt and sand can be separated by evaporation.
(c) Evaporation is when a gas becomes a liquid.

Light Energy

9.1 Sources of light

Activity 9.1

In pairs

What to do

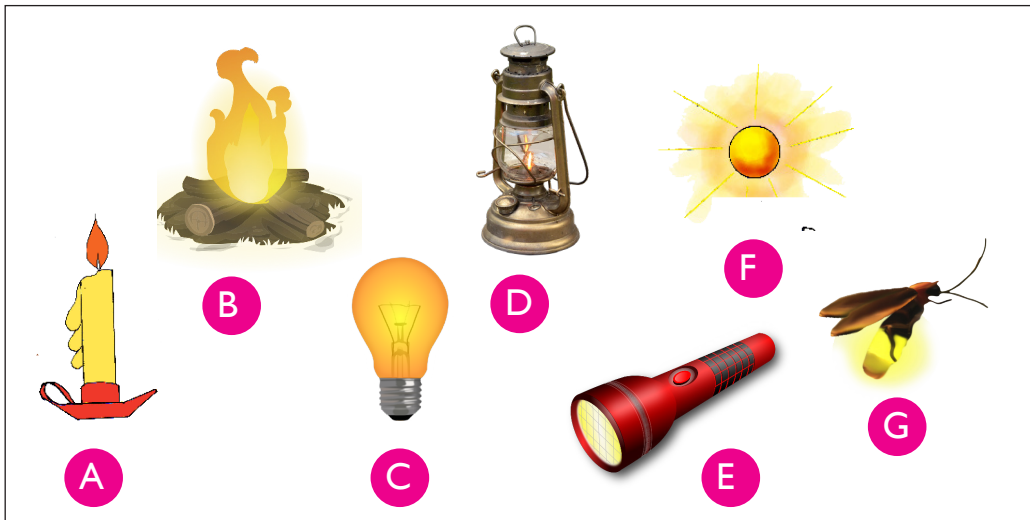

1. Can you name the sources of light in the picture above?
2. Where do you use these sources of light?
3. Which sources of light do you use at home and in school?
4. Which sources of light are natural?
5. Which sources of light are man-made?
6. Find out the sources of light used in your community. Which fuel do they use?

Learning points

- Light is a form of energy.
- Anything that produces light is called a source of light.
- The main source of light is the sun.
- Other sources of light commonly used in your locality are:

- a) Torches b) Lamps c) Candles
- d) Electricity e) Stars

- Lamps use fuel like paraffin and gas to give light. There are different types of lamps.



Gas lamp

Hurricane lamp

Pressure lamp

Tin lamp

- Which one do you use at home?
- Some sources of light are natural. Examples are sun, stars, glow-worms and fireflies.
- Some sources of light are man-made. Examples are torches, lamps, candles, and electric bulbs.
- Man-made sources of light are also called artificial sources of light.

Remember!

The moon is not a natural source of light. It reflects light from the sun.

Check your progress 9.1

- The fuel commonly used in tin lamps and hurricane lamps is _____.
- Classify the following sources of light as artificial or natural. Fill in your answers in the table.
Stars, torch, sun, tin lamp, electric bulb, firefly and pressure lamp

Artificial sources of light	Natural sources of light

9.2 How light travels

Activity 9.2

 In groups

Materials

- Same size cards
- candle

What to do

1. Place same-size cards with holes at their centres in a line and source a of straight light at one end as shown below.

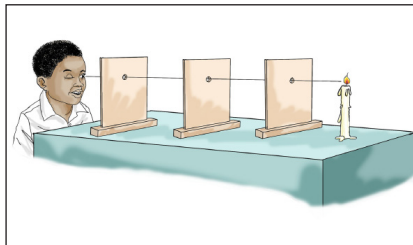

2. If one of the cards is displaced such that the holes are not in a straight line as shown below no light will be seen by the observer.

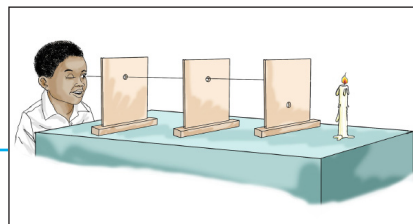

Learning points

- This shows that light travels in a straight line.
- Some sources of light are specifically made to direct the light in a

particular direction. For example the the headlights of a vehicle and a torch.

- We are able to see things because light travels from them to our eyes.
- Light travels in all directions.

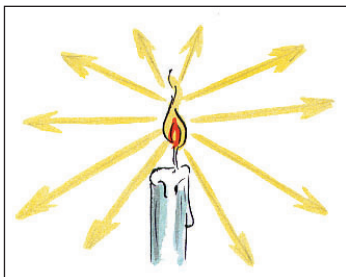

- We cannot see things in a hidden corner because light travels in a straight line.

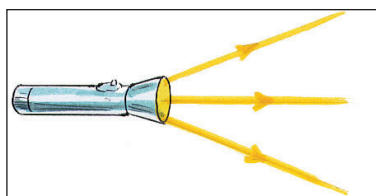

- The straight path followed by light from its source is called a ray.
- Many rays of light form a beam.

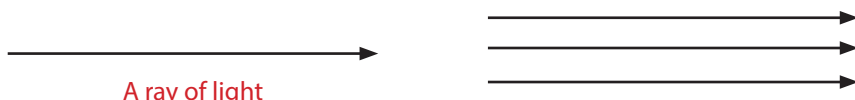

Activity 9.3

 In pairs

Materials

- A candle
- A piece of flexible plastic tube about 30 cm long. This can be obtained from a hose pipe.
- A matchstick

What to do

1. Light a candle and place it on the table
2. Observe the candle using straight (unbent) tube as shown.



- Are you able to see any light coming from the candle? What does this show?
3. Now bend the tube and once again try to observe the candle. Do you see the candle light. What does this show?

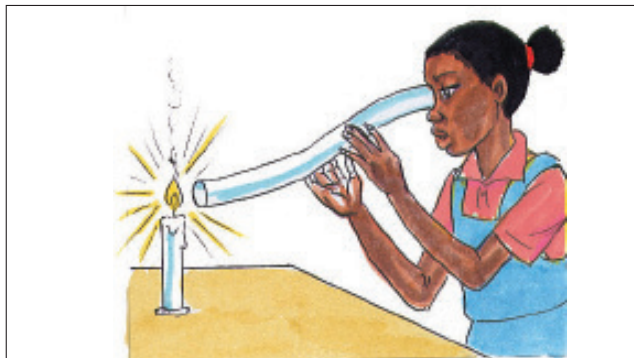

Check your progress 9.2

1. Class level 2 pupils carried out the following experiment during a science lesson.

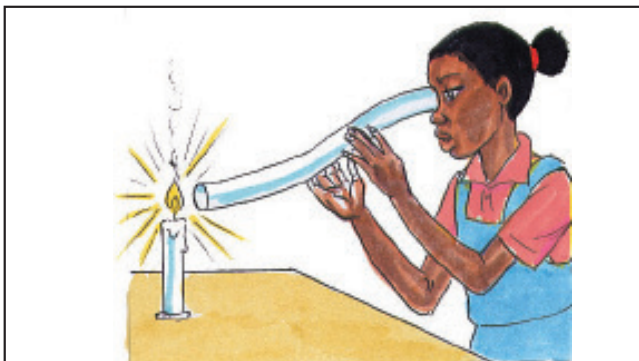

What property of light were the pupils investigating?

2. Write True or False.

- a) Light travels in only one direction.
- b) Light travels in all directions.
- c) Light travels around objects.

4. At what position are light bulbs fixed in a house?

5. Find out why light bulbs are fixed in that position.

9.3 Behaviour of light in different materials

Activity 9.4

 As a class

Materials

- A clear polythene paper
- A sheet of clear glass
- A block of wood
- White paper
- Mirror
- Sellotape
- Manila paper
- A piece of cloth
- A coloured glass
- Glass of water
- Torch

What to do

1. Tape a white paper on the classroom wall.
2. Light the torch and direct light rays onto the black paper.
3. Place each of the materials in front of the torch.
 - What happens when light falls on each object?
 - Does the light pass through the object?
 - Where are some of these materials found in our homes?
4. Record your observations in the following table.

Light passes through	Light does not pass through
1. Clear glass	

Learning points

Materials like water and clear glass allow light to pass through them. These materials are called transparent materials.

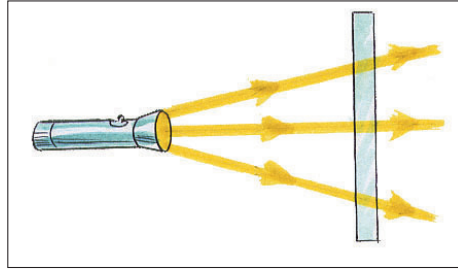

We can see through transparent materials.

Some materials allow some light to pass through them. These materials are called translucent materials.

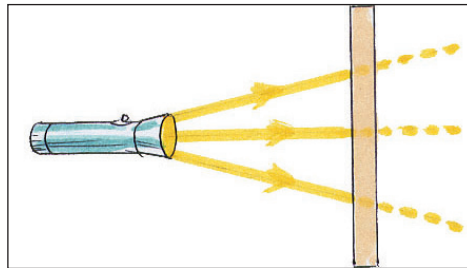

We cannot see clearly through translucent materials.

Examples of translucent materials are thin tissue paper, car tinted windows and clouds.

Some materials like wood and cloth do not allow light to pass through them. These materials are called opaque materials.

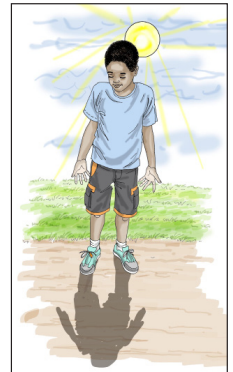

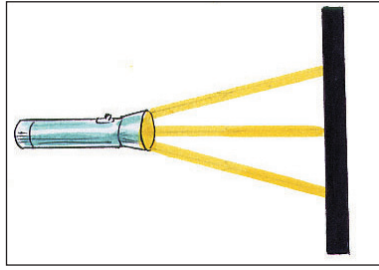

- Materials which do not allow light to pass through form shadows.
- A shadow is formed when the path of light is blocked by an object.

Activity 9.5

 In groups

What to do

1. List down materials found around the school.
2. Predict whether each material is transparent, translucent or opaque. Record your prediction on a table.
3. Look for the different materials and fill a table like the one shown below.
 - Are they transparent, translucent or opaque?
 - Did you predict each item correctly?

Material					Uses

4. Think about items around the community or in your homes that are transparent, translucent, and opaque. Write them in your

Check your progress 9.3

1. Which of the following materials allows light to pass through?

A. Clear glass.	B. Block of wood.
C. Your hands.	D. Cardboard.

2. We can see clearly through _____.
 - A. a clear empty glass
 - B. a glass with milk
 - C. a classroom wall
 - D. a wooden door
3. Give any two objects that do not allow light to pass through them.
4. Objects that do not allow light to pass through them form _____
5. Complete the table below. The first one has been done for you.

Object	Material
Car windscreen	Materials that allow light to pass
Clothes	
Walls of houses	
Mirror	
Clear polythene paper	

exercise books.

Learning points

- 1. Making windscreens in vehicles.
 2. Fitting window panes.
 3. In making spectacles.
- Opaque materials are used in making:
 1. Clothing to cover our bodies.
 2. Walls of houses.

9.4 Uses of light

Seeing

Activity 9.6

 In pairs

Materials

Heavy coloured piece of cloth

What to do

1. Blindfold your friend.

2. Lead him or her to the back of the class.
3. Let him or her walk slowly to the front of the class without being led?
4. Let your friend blindfold you and do the same.
 - What happens?
 - Can you or your friend find your way easily to the front of the classroom?
 - Can your friend see you? Can you see your friend?
 - How is light useful to us?

Activity 9.7

 Individually

What to do

1. Switch off the source of light in your house at night.

What happens? Are you able to see things around you?

2. Now put the light on. What do you notice?

Learning points

- Light helps us to see things around us.
- Light moves from objects to our eyes so we can see.

Healthy growth in plants

Activity 9.8

 In groups

Materials

- Two identical containers
- Water
- Bean seeds
- Soil

What to do

1. Put some soil in the containers.
2. Plant the same number of seeds in each container.

3. Sprinkle some water into the containers.
4. Place one container on the window sill where it can receive sunlight. Place the second container in a dark corner in the classroom.
5. Observe what happens after two weeks. Did the seeds germinate?
 - Which plants look healthier? The ones that were kept in the dark or in the sunlight?
 - Why do you think the plants look different?

Learning points

- Light is needed for healthy growth of plants.

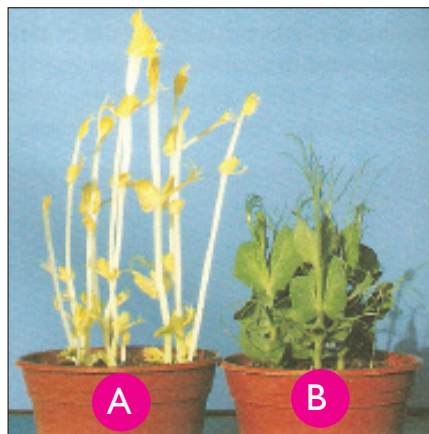

- Green plants use light to make their own food. Plants growing in places with plenty of sunshine grow strong and healthy.

Light is used in communication

Activity 9.9

 As a class

Materials

Charts on the traffic lights model.

What to do

1. Visit a town where movement of vehicles is controlled by traffic lights.
 - What are the colours on the traffic lighting system?
 - What does each of the colours mean to the road users?

Check your progress 9.4

1. Plants growing in _____ will grow healthy.
 - A. shade
 - B. dark place
 - C. plenty of sunshine
 - C. a classroom corner
2. Our eyes cannot see without _____.
3. Draw and colour traffic lights model, indicate what each of the colours mean.
4. Look at this picture.



We need light to take _____.

5. Write True or False.
 - (a) When traffic lights turn red, a driver must stop.
 - (b) Plants growing in a dark place appear long and thin.

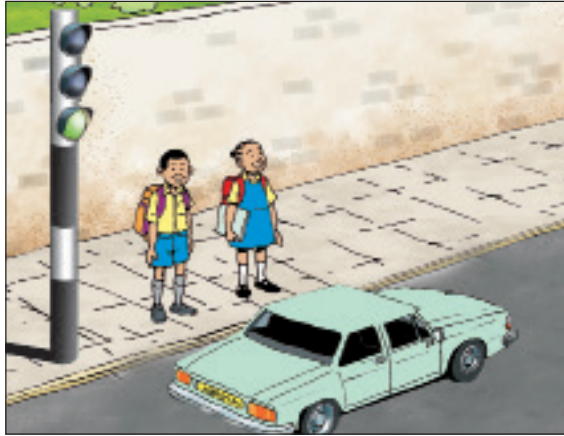

2. Draw and label the traffic lights model.

Learning points

- Light is used to communicate in a traffic light system.
- The lights flash to send messages to the road users.
- Red light means stop.
- Orange (amber) light means get ready to stop or to go.
- Green light means go.

Heat energy

9.5 Sources of heat

Activity 9.10

 In pairs

What to do

Look at the pictures of sources of heat below.

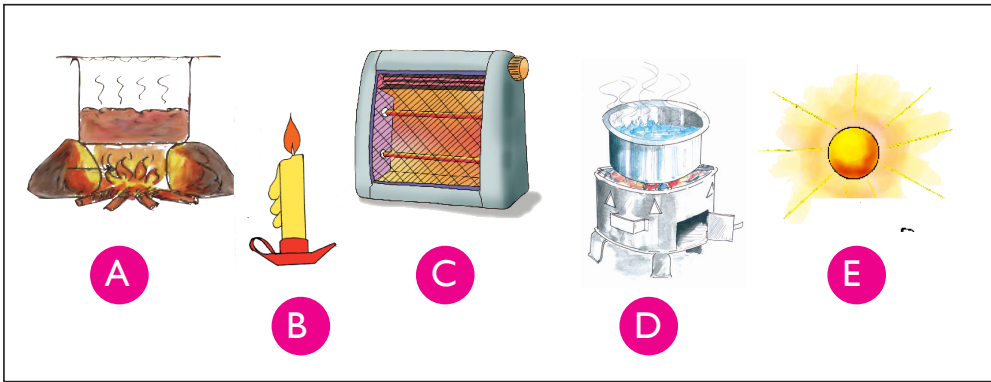

1. Can you name the source of heat in each picture? Write the names in your exercise book.
2. Can you think of sources of heat used in your community? Find out and write them down in your exercise book.

3. Discuss:

- a) What happens when you stay outside on a hot day?
- b) Why animals rest under shades of trees when the sun is shining?

Learning points

- The main source of heat is the sun. Heat from the sun makes us warm. Other sources of heat are fire, electricity and gas.
- Fire produces heat when firewood, charcoal, kerosene or gas burns.
- Heat is produced by kerosene stoves, candles, charcoal stoves, and gas cookers.



Electric stove

Charcoal stove

Fire place

- Electricity can be used to produce heat in electric cookers, heaters and irons.
- Sources of heat are either natural sources or artificial sources.
- The sun is a natural source of heat.
- Electricity and candles are examples of artificial sources of heat.

Check your progress 9.5

1. Identify and circle the sources of heat in the puzzle.

F	K	T	J	U	R	P	S
K	T	L	V	I	X	K	T
X	F	I	R	E	Z	E	O
H	M	O	T	B	W	E	V
E	X	C	A	N	D	L	E
A	D	A	G	H	M	U	O
T	G	H	A	P	Y	Q	E
E	P	E	S	T	F	G	W
R	G	M	J	K	P	R	Y

2. Name the things that use electricity to produce heat.

Activity 9.11

Individually

Materials

- Piece of stick
- Piece of wood

What to do

1. Rub your hand against each other very fast and repeatedly.

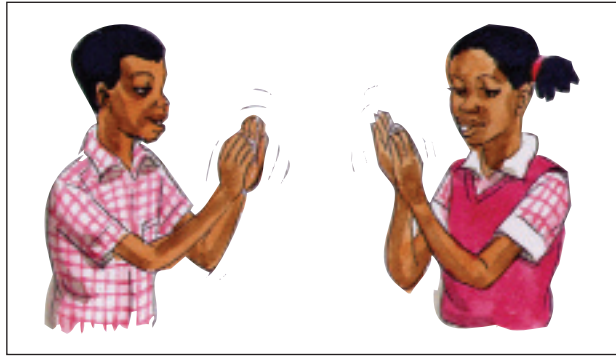

2. Stop rubbing and immediately touch your cheeks. Does it feel warm? Where does the heat come from?
3. Rub the stick against a piece of wood. Do it fast and repeatedly. Touch the stick. What happens? Does it feel hot? Be careful not to get burnt as you touch the stick.

Learning points

- Rubbing materials against each other produces heat energy.
- The heat is caused by a force called friction.
- Friction is the resisting force of an object as it moves over another object.

9.6 How heat travels

Activity 9.12

 In pairs

What to do

1. Discuss why the following things happen.
 - a) When you bask in the sun you feel warm.
 - b) When cold water in a cooking pan is heated, it boils.
 - c) A metal rod placed on fire becomes hot.
2. Record your findings in your exercise books.

Activity 9.13

 As a class

Materials

- A source of heat
- 20 cm long metal rod
- 20 cm long wooden rod
- 20 cm long plastic rod
- 20 cm long glass rod
- Watch

What to do

1. Light a candle or a charcoal stove.
2. Place one end of the metal rod on the flame.
 - What happens?
 - Do you feel any heat immediately?
 - After how long does the heat reach your hand?
 - How does the heat reach your hand?
3. Repeat the activity using the wooden, plastic and glass rods.
 - What happens?
 - How long does it take for the heat to reach your hand?

Check your progress 9.6

1. Which one of the following does not allow heat to travel through it?

A. A wooden spoon.	B. A metallic spoon.
C. A metallic plate.	D. A wire.
2. _____ allows heat to travel through it.
3. Heat travels through _____ faster than in liquids.
4. From which rod will the candle drop first in the setup below?

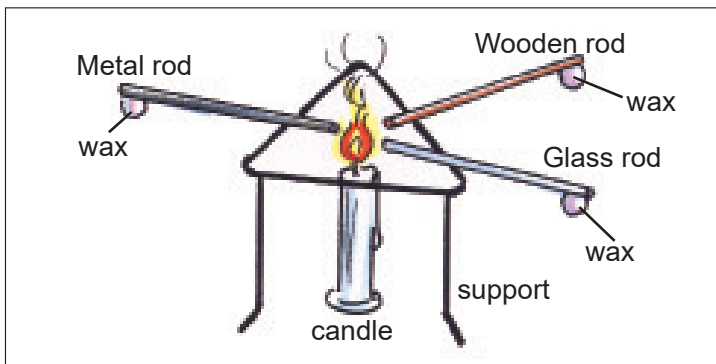



A



B

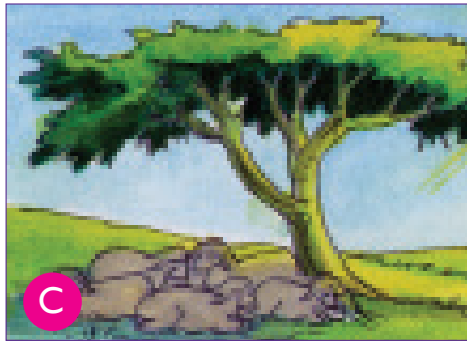

C

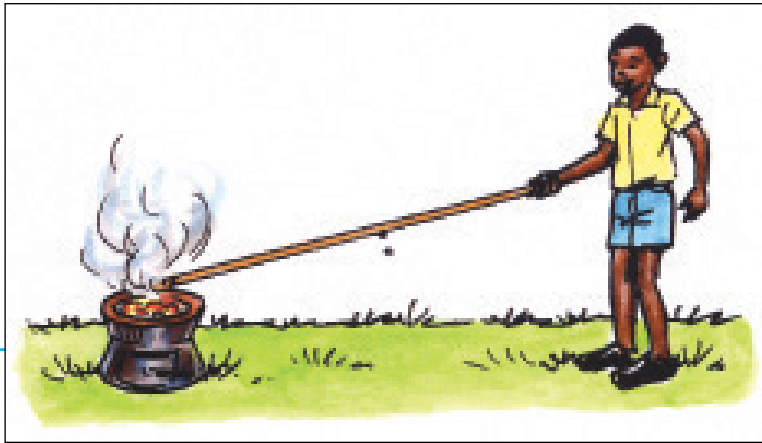

4. Place your hands 20 cm away from the flame.,
 - What happens?
 - Do you feel the heat?
 - How does the heat reach your hand?

Learning points

- Heat travels through solids such as metals by conduction.
- When cold water in a cooking pot is heated, it becomes hot. This is because heat travels through water. Heat travels through liquids such as water by convection.
- When you place your hand close to a candle flame, you feel the heat. This is because heat travels through air by convection.
- Heat travels faster in solids than in liquids
- Heat travels faster in liquids than in gases.
- Heat from the sun travels through empty space to the earth. That is why we feel heat from the sun.
- Heat travels through empty space by radiation.

Remember!

Heat travels from a hot place to a cold place.

9.7 Uses of heat

Activity 9.14

 In groups

What to do

Discuss with your group members on what is taking place in the pictures below.

Use the questions below as your guide.

- What happens when you hang wet clothes out in the clothes line?
- Why do animals hide under shades of big trees when it is hot?
- Why do farmers dry grains in the sun after harvesting?

Drying

Activity 9.15

 In groups

Materials

- Clean water
- Basin
- Handkerchief

What to do

1. Use clean water and soap to wash your handkerchief.
2. Rinse the handkerchief and dry it in the sun.
3. Collect the handkerchief after ten minutes. What do you notice?
4. What other things are dried using heat from the sun? Record your

findings in your exercise books.

Learning points

- Heat energy is used for drying.
- The heat from the sun helps to dry wet clothes.
- Heat from the sun also



helps to dry some food like maize, rice and beans.

Warming

Activity 9.16

 In pairs

Check your progress 9.7

1. Why do we dry grains before storage?
2. The tool below uses _____ to produce heat.



3. _____ is the main source of heat energy.
4. Write True or False.
 - a) Heat from the sun makes us warm.
 - b) Drinking hot tea or porridge can warm our bodies.
 - c) Heat from the sun causes food to rot.

Electricity

10.1 Static electricity

Activity 10.1

 In pairs

What to do

Discuss the following:

1. You hear a crackling sound when removing your pullover on a cold day.
2. You hear a crackling sound when combing dry hair.
3. What happens when you wipe window panes using a dry cloth on a dry day?

Activity 10.2

 In groups

Materials

- Plastic ruler
- Pieces of paper
- Plastic pen

What to do

1. Cut the paper into small pieces. Place them on a working table.
2. Rub the plastic ruler gently on your dry hair or pullover.
3. Slowly lower the ruler near the pieces of paper.
 - What happens between the plastic ruler and the pieces of paper?
 - Why does this happen?
4. Now turn the ruler so that you are holding the end you rubbed. Try picking the pieces of paper again. What happens? Does this part of the ruler which was not rubbed pick up papers?
5. Repeat the activity using a plastic pen.
6. Observe and discuss what happens.
7. Record your observation in your exercise book.

Learning points

- Electricity is a type of energy. Electricity can be in one place or move from place to place.
- Electricity that gathers in one place is called static electricity. It is called static because it does not move. Static electricity is made up of electric charges that do not move.
- Static electricity often happens when we rub things together.

Activity 10.3

 As a class

Materials

- Balloons
- Strings
- Pullover

What to do

1. Blow air into two balloons. Then tie off their mouths.
2. Put a mark as X on one side of one balloon. This will let you know which area you rubbed.
3. Rub one of the balloons against your pullover at the point mark X.
4. Try to stick the balloon on a wall near the point mark X.



- What happens?
 - Does the balloon stick to the wall?
5. Now try to stick the balloon which was not rubbed on the wall.
 - What happens?
 - Does the balloon stick to the wall?
 6. Record your observation in your exercise book.

Learning points

- Rubbing a balloon on a pullover gives it static electricity. This makes the balloon stick to the wall at the place that was rubbed.
- The balloon that was not rubbed did not stick on the wall.

Check your progress 10.1

1. Which of the following is an example of static electricity?
 - A. Electricity for a light bulb.
 - B. Your shirt sticking to your body.
 - C. Electricity in an electric cooker.
 - D. None of the above.
2. Clothes often stick together because of _____.
 - A. Friction
 - B. Electric charge
 - C. Static electricity
 - D. Current electricity
3. Write True or False.
 - a) Static electricity moves in one direction.
 - b) An inflated balloon rubbed on dry hair sticks to a wall.
 - c) Lightning is not static electricity.

10.2 Current electricity

Activity 10.4

 As a class

What to do

1. What do you use at home to give you light at night? Tell your teacher.
2. Name the items shown in the picture below.



3. Name five devices that use the items in the pictures.

Learning points

- Dry cells are commonly used in torches, radios, cameras and remote controls.
- The end of a dry cell with metal caps are called terminals.
- The metal cap at the top forms the positive terminal (+).
- The metal cap at the bottom forms the negative terminal (-).

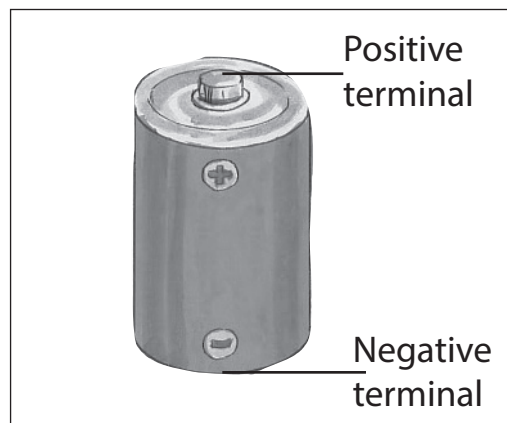

- Two or more dry cells make up a battery. Dry cells are also called

torch batteries.

- Dry cells have chemicals inside. These chemicals produce electricity.

Activity 10.5

 In pairs

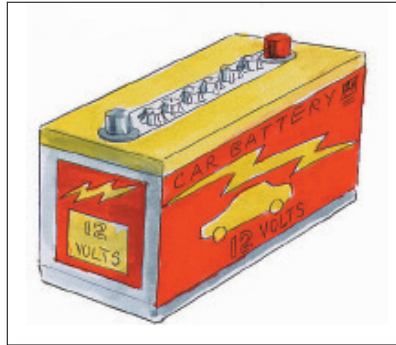

1. Have you ever seen a battery like the one above?
2. Does the battery have anything similar with a dry cell?

3. Where else do you think the battery can be used?

Learning points

- A car battery is used to run a car.
- It can also be used to run other electrical equipment. Examples are radios, light bulbs and televisions.
- Like a dry cell, a car battery has positive terminal and negative terminals.

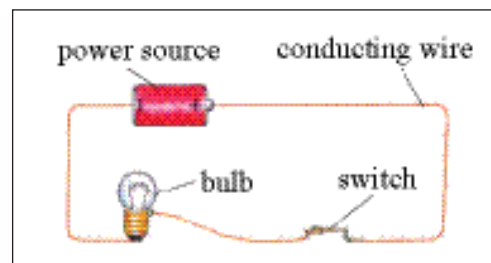



- A car battery also has chemicals that produce electricity.

Remember!

A car battery can be recharged and re-used. To recharge means to put electric energy back into a battery whose energy has been used up.

Activity 10.6

 In groups

Materials

- Dry cells
- Wire
- Bulbs
- masking tape

What to do

1. Study the following circuit showing connected dry cells.
 2. How do you think we can make the bulb light? Tell your teacher.
3. Now connect your dry cells as shown in the diagrams. Test if your prediction was correct.

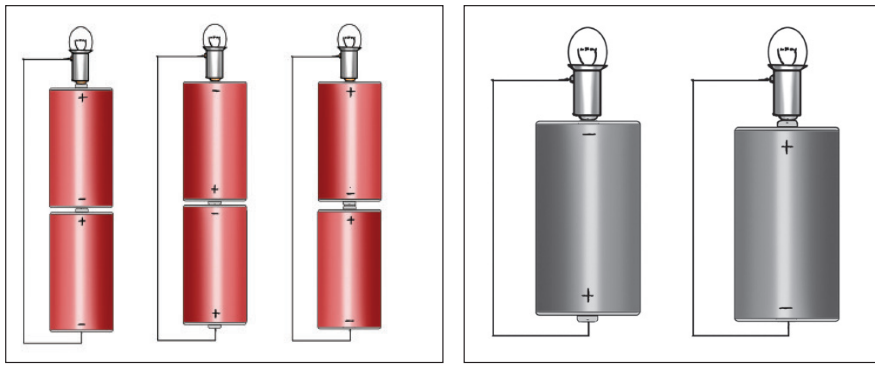

5. Try different connections. How many other ways can you connect for the bulb to light?
6. Draw connections that work and those that do not work in a table.

Learning points

- Electricity that moves from one place to another is called current electricity.
- For the bulb to light, the wire must touch the correct points of

Check your progress 10.2

contact on the bulb.

- Connections that allow the bulb to light are called simple electric circuits.
- A circuit is the complete path that electricity follows.

Activity 10.7

 In groups

Materials

- A torch
- Dry cells

What to do

1. Put two dry cells in a torch. The positive terminal of one dry cell should be connected to the negative terminal of the next cell.
2. Now put on the switch. What happens after putting on the switch?

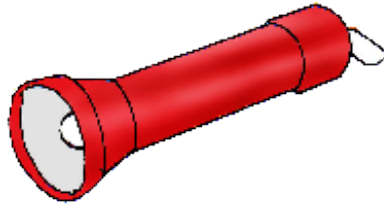

3. Put off the switch. What happens?

Learning points

- A switch is used to turn an electric device on and off.
 - When the switch is on, electric current flows. This makes the bulb to light. We say the switch completes the circuit.
 - When the switch is off, electric current stops flowing. This makes the bulb in the torch to go off. We say the switch has broken the circuit.
1. Name any three equipment at home that use electricity.
 2. Why should we switch off lights when they are not in use?
 3. Write True or False.
 - a) When a switch is on, electricity does not flows.
 - b) Two or more dry cells make up a battery.
 - c) Torch batteries have chemicals that produce electricity.
 4. Draw any two simple circuits that will light a torch bulb.

10.3 Connecting dry cells

Activity 10.8

 In groups

Materials

- | | |
|---------------|----------------|
| • Dry cells | • Wire |
| • Torch bulbs | • Masking tape |

What to do

1. Arrange your circuit to look like the one shown below.

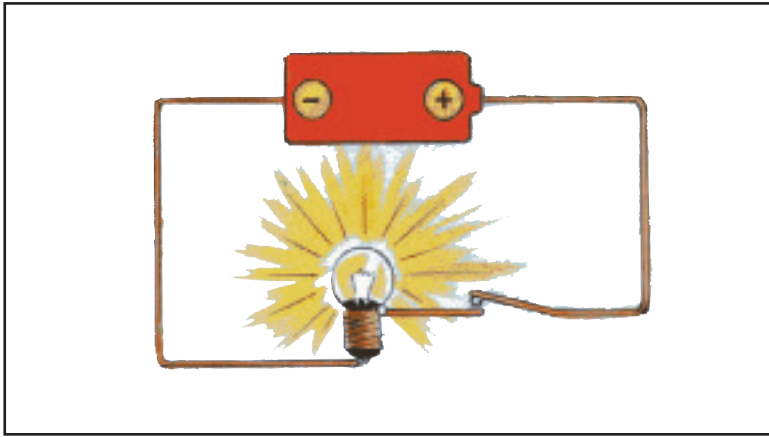

What happens to the bulb? Does it light?

2. Try out the connections in the following diagrams. Record your observations in your exercise books.

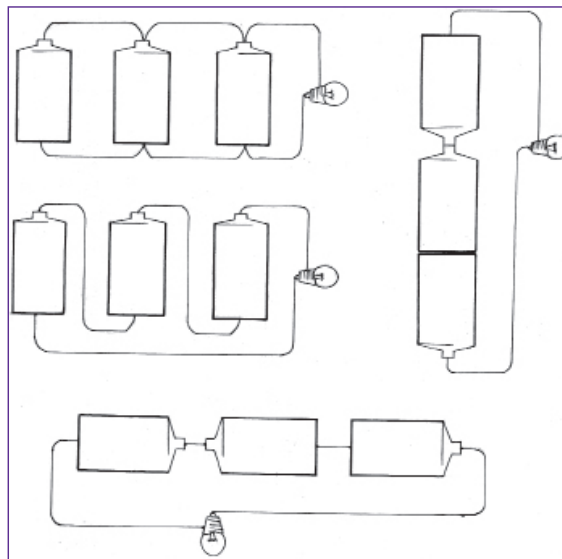

Learning point

- The bulb lights only when the connection is made correctly as shown in the connection in the following picture.

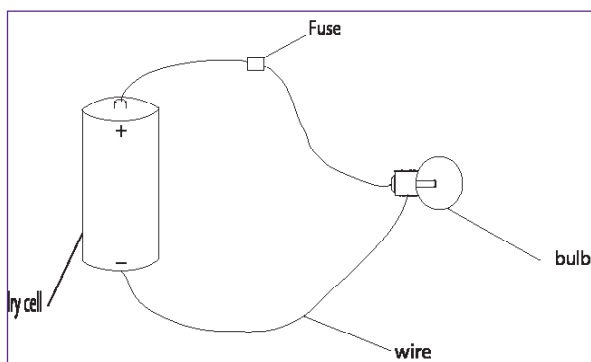

- When the dry cell is connected to the glass part of the bulb, the bulb does not light.

Number of cells and brightness of the bulb

Activity 10.9

 In groups

Materials

- Four dry cells
- Wire
- Torch bulb
- Masking tape

What to do

1. Connect your materials as shown below.

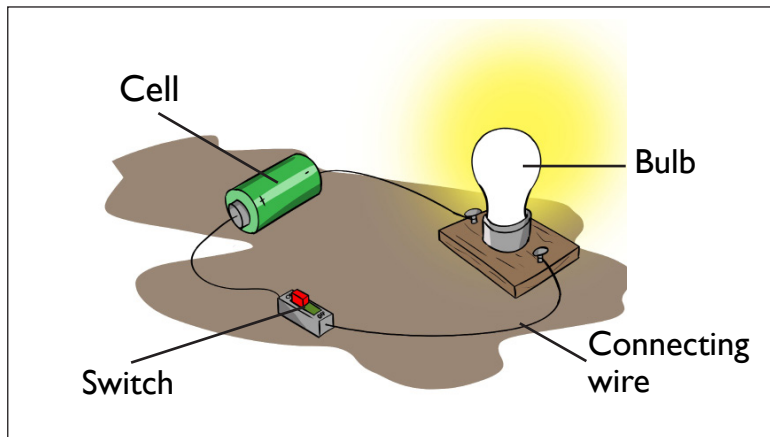

2. Observe the brightness of the bulb. How do you think we could increase its brightness?
3. Add a dry cell to the connection. What happens to the brightness of the bulb? Does the bulb become brighter or dimmer?
4. Keep adding a dry cell to the connection. What happens to the brightness of the bulb each time you add a dry cell? Does the bulb become brighter or dimmer?
5. Draw the arrangements you have made in your exercise book.

Learning point

- As you add dry cells to the connection, the bulb lights brighter.

Check your progress 10.3

Safety precautions when dealing with electricity

Activity 10.10

 In pairs

What to do

Study the following picture.

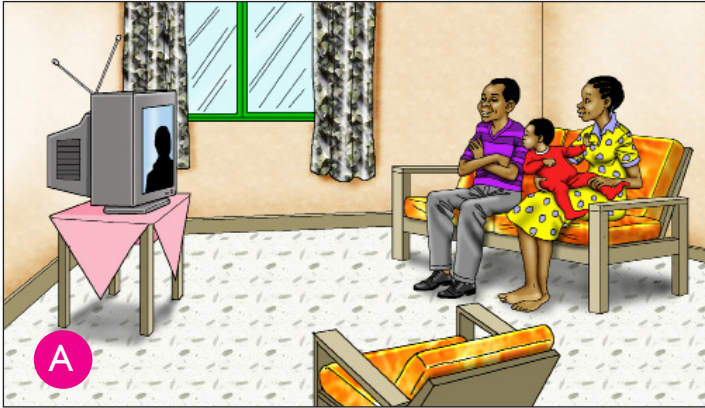

1. Observe the picture above. What is the girl in the picture doing?
2. How is the electricity used in the picture?
3. What are some of the uses of electricity in our homes?
4. Discuss and name devices which use electricity at home.
5. What harm can electricity cause?
6. How do we prevent harm from electricity?

Learning points

- Electricity can cause burns, shocks and even death.

Here are some rules for using electricity safely.

- Do not touch any device connected to electricity with wet hands.
- Do not plug too many cords in a socket.



- Do not play below electric wires.
- Do not use electric cord that is broken or cut.

Electricity flows easily through our bodies. This is because our bodies are made of a lot of water. Electricity flows quickly through water.

Remember!

Switching off electricity during the day helps to conserve energy. It also reduces the cost of electricity.

1. In which of these conditions will the connections will the bulb light brighter?

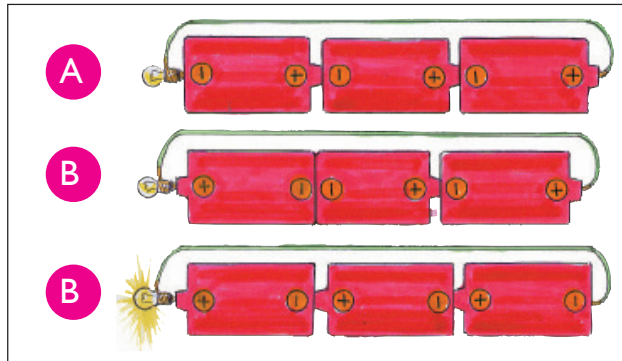

2. Give any two dangers of touching electric wires with wet hands?
3. How safe is the activity below?.

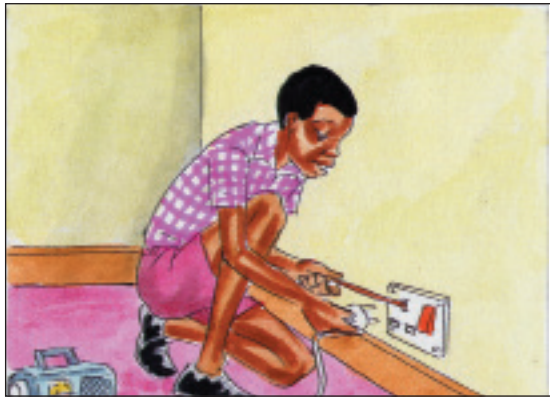

4. Where are you likely to find the following sign.



Magnetism

10.4 How to make magnets

Activity 10.11

 In pairs

1. Talk to your friend about the pictures below.

Check your progress 10.4

1. Adding dry cells makes an electromagnet _____.
A. stronger B. to stop working
D. weaker
2. What happens when you rub a needle using a magnet?
A. It pushes away staple pins.
B. It picks up staple pins.
C. It becomes a permanent magnet.
D. It picks up pieces of paper.
3. Name two ways of making a magnet.
4. Write True or False.
(a) An electromagnet can be turned on and off.
(b) Dry cells produce electricity in an electromagnet.

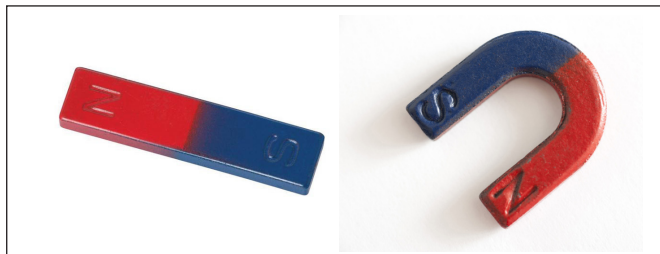

2. Have you ever played with magnets? What did you do with the magnets?
3. What are magnets used for?

Remember!

Use the the same magnet each time. Hold the magnet over each object for the same amount of time.

Materials

- A bar magnet
- Office pin or a needle
- Staple pins

What to do

1. Hold the needle or pin flat on the table.
2. Rub one end of the magnet along the needle from the eye to the tip continuously in one direction as shown below.

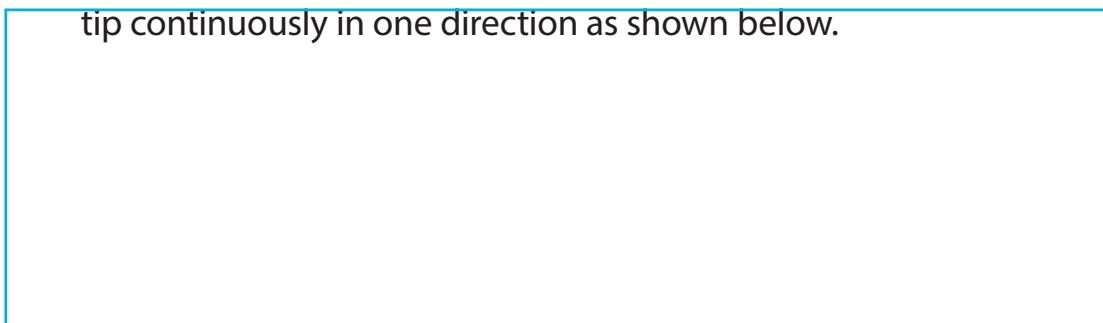

Check your progress 10.5

Group the following materials as magnetic or non-magnetic.

Silver coin, office pins, staple pins, paper, rubber, stick, iron nail, spoon, pencil, eraser, socks, paper-clip, book and clothes peg.

Magnetic	Non-magnetic

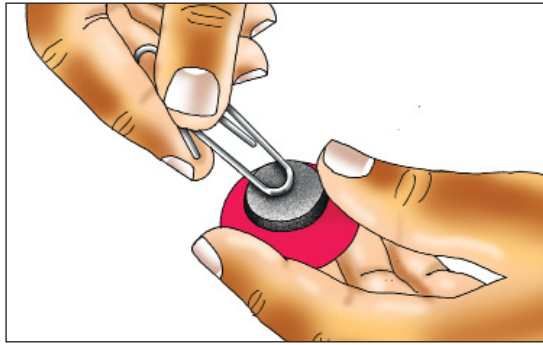

3. Continue rubbing quickly as many times as possible.
Note: When rubbing do not move the magnet back and forth.
4. Bring the needle close to staple pins. What happens?

Learning points

- A magnet is a special type of metal that attracts certain metals as well as other magnets.
- We can make a simple magnet by continuously rubbing a magnet along a metal in one direction.

Activity 10.13

 In groups

Materials

- Dry cells
- Masking tape
- Insulated copper wire
- An iron nail

What to do

1. Coil the copper wire on the nail. Make as many coils as possible.
2. Remove the plastic coating at the ends of the wire.
3. Bring the nail close to staple pins. What happens?
4. Attach the ends of the wire to the terminals of the dry cell. Use masking tape as shown below.

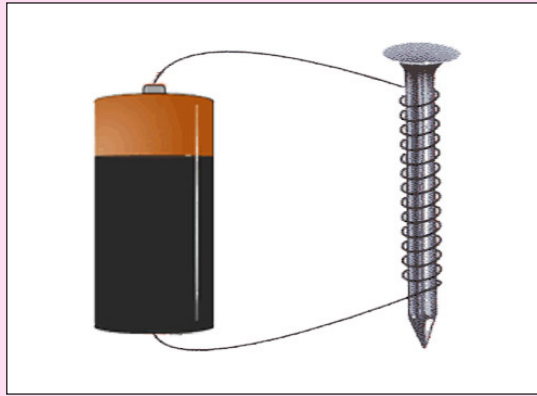

5. Now bring the nail close to staple pins. What happens?
6. Add another dry cell to the connection. Observe and record what happens to the staple pins.

Warning!

The ends of the wire may get hot when they touch the terminals of the battery. Be careful when taping them.

Learning points

Check your progress 10.6

1. Which of the following is a magnetic material?
A. Paper B. Plastic
C. Iron nail D. Wood
2. Name any three non-magnetic materials used at home.
3. When a magnet pushes an object we say it has _____ the object.
4. Draw a bar magnet and label its poles.
5. Write True or False.
 - a) A south pole of one magnet repels a south pole of another magnet.
 - b) A north pole repels a south pole.
 - c) A south pole can also be called a north pole.

- An electromagnet is a magnet that is made using electricity. It can be turned on and off.
- Adding dry cells makes the electromagnet stronger.
- The electromagnet stops working when the cells are removed.

10.5 Grouping materials using a magnet

Activity 10.14

 In groups

Materials

- Spoon
- Aluminium foil
- Pen
- Piece of stick
- Rubber
- Copper coin
- Iron nail
- Plastic plate
- Office pins
- Pencil
- Silver coin
- Paper
- Steel wool
- Scissors

What to do

1. Place a bar magnet close to each of the materials above. What happens to each of the materials?
2. Record your observations in a table like the one shown below

Materials attracted by the magnet	Materials not attracted by the magnet
1	
2	
3	
4	
5	
6	
7	

Learning points

- Materials attracted by a magnet are called magnetic materials. Examples are metal spoon, steel wool, office pins, and silver coin.
- Materials that are not attracted by a magnet are called non-

Did you know?

The earth behaves like a giant magnet. It has a magnetic north and south poles.

Check your progress 10.7

1. Class Four pupils sprinkled iron filings on a piece of paper. What happened when they moved a bar magnet underneath the paper?
 - A. The iron filings moved in the direction opposite that of the magnet.
 - B. The iron filings moved in the direction of the magnet.
 - C. The iron filings did not move.
 - D. The iron filings stuck to the paper.
2. Abdul sprinkled iron filings on a tin plate. Then she moved a bar magnet underneath the plate. Why did the iron filings not move?
3. Write True or False.
 - (a) A magnet is strongest at the poles.
 - (b) Iron filings are magnetic.
 - (c) The middle of a magnet attracts more iron filings.